



±15kV ESD-Protected USB On-the-Go Charge Pump and Comparators in UCSP

MAX3355E

General Description

The MAX3355E integrates a charge pump and comparators to enable a system with an integrated USB on-the-go (OTG) dual-role transceiver to function as a USB OTG dual-role device. USB OTG facilitates the direct connection of peripherals and mobile devices such as PDAs, cellular phones, MP3 players, and digital cameras to one another without a host PC.

The MAX3355E's internal charge pump supplies V_{BUS} power and signaling that is required by the transceiver as defined in *On-the-Go Supplement to the USB 2.0 Specification, Revision 1.0*. The MAX3355E features ID detection and internal comparators for monitoring V_{BUS} . The V_{BUS} status outputs are used during negotiation for the USB according to the session request protocol (SRP) and host negotiation protocol (HNP).

The MAX3355E operates with logic supply voltages (V_L) as low as 1.65V, ensuring compatibility with low-voltage ASICs. The device also features a logic-selectable 1 μ A shutdown mode.

The MAX3355E has built-in ± 15 kV ESD-protection circuitry to protect the V_{BUS} and ID_IN pins. The device is available in a miniature 4 x 3 chip-scale package (UCSP), as well as a 14-pin TSSOP package, and is specified for operation over the -40°C to +85°C extended temperature range.

Applications

Cell Phones
PDAs

MP3 Players
Digital Cameras

Features

- ◆ Guaranteed 8mA (min) V_{BUS} Charge-Pump Output
- ◆ ± 15 kV ESD Protection on V_{BUS} and ID_IN
- ◆ Up to +6.0V Backdrive Capability for V_{BUS}
- ◆ +2.6V to +5.5V Operating Voltage Range
- ◆ V_L Operates Down to +1.65V
- ◆ Guaranteed V_{BUS} Input Impedance When Not Driven
- ◆ Automatic C_{LOAD} Detection
- ◆ Comparators for Host Negotiation Protocol
- ◆ ID_IN Detection
- ◆ Available in 4 x 3 UCSP or 14-Pin TSSOP Package

Ordering Information

PART	TEMP RANGE	PIN-PACKAGE	TOP MARK
MAX3355EEBC-T*	-40°C to +85°C	4 x 3 UCSP	ABE
MAX3355EEUD	-40°C to +85°C	14 TSSOP	—

*Future product—contact factory for availability.

Pin Configurations appear at end of data sheet.

Functional Diagram

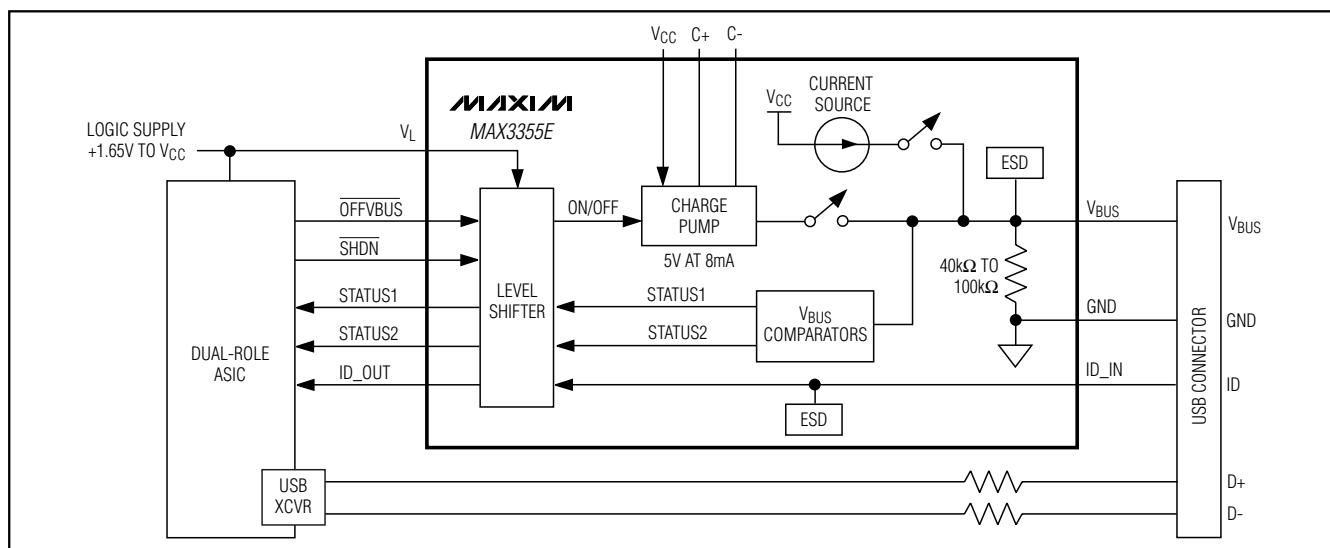

±15kV ESD-Protected USB On-the-Go Charge Pump and Comparators in UCSP

ABSOLUTE MAXIMUM RATINGS

(All voltages referenced to GND)

V _{CC} , V _L , V _{BUS} , ID_IN	-0.3V to +6.0V
C+	(V _{CC} - 0.3V) to +6V
C-	-0.3V to (V _{CC} + 0.3V)
OFFVBUS, SHDN, STATUS1, STATUS2, ID_OUT	-0.3V to (V _L + 0.3V)
V _{BUS} Short Circuit to GND	Continuous
Output Current (all other pins)	±15mA
Continuous Power Dissipation (T _A = +70°C)	
4 x 3 UCSP (derate 6.5mW/°C above +70°C)	520mW

14-Pin TSSOP (derate 9.1mW/°C above +70°C)	727mW
Operating Temperature Range	-40°C to +85°C
Storage Temperature Range	-65°C to +150°C
Junction Temperature	+150°C
Lead Temperature (soldering 10s)	+300°C
Bump Temperature (soldering)	
Infrared (15s)	+200°C
Vapor Phase (20s)	+215°C

Stresses beyond those listed under "Absolute Maximum Ratings" may cause permanent damage to the device. These are stress ratings only, and functional operation of the device at these or any other conditions beyond those indicated in the operational sections of the specifications is not implied. Exposure to absolute maximum rating conditions for extended periods may affect device reliability.

ELECTRICAL CHARACTERISTICS

(V_{CC} = +2.6V to +5.5V, V_L = +1.65V to V_{CC}, C₁ = 0.1μF, V_{CC} decoupled with 1μF capacitor to GND, V_L decoupled with 0.1μF capacitor to GND, C_{LOAD} = 1μF (min), ESR_{LOAD} = 1Ω (max), T_A = T_{MIN} to T_{MAX}. Typical values are at V_{CC} = +3.0V, V_L = 1.8V, T_A = +25°C, unless otherwise noted.) (Notes 1, 2)

PARAMETER	SYMBOL	CONDITIONS	MIN	TYP	MAX	UNITS
Supply Voltage	V _{CC}		2.6		5.5	V
Logic Supply Voltage	V _L		1.65		V _{CC}	V
Logic Supply Current	I _L				100	μA
Operating Supply Current	I _{CC}	No activity on V _{BUS} ; comparator and reference active			200	μA
		Device A configured, $\overline{\text{OFFVBUS}} = V_L$, I _{LOAD} = 8mA, charge pump on			20	mA
Shutdown Supply Current	I _{CCSHDN}	Device B configured, SHDN = GND			1	μA
		Device A configured, SHDN = GND		30		
Thermal-Shutdown Protection Threshold		Device A configured, $\overline{\text{OFFVBUS}} = V_L$, charge pump on		+150		°C
Thermal-Shutdown Protection Hysteresis		Device A configured, $\overline{\text{OFFVBUS}} = V_L$, charge pump on		+20		°C
LOGIC INPUTS AND OUTPUTS						
STATUS1, STATUS2, ID_OUT Output Voltage	V _{OH}	I _{SOURCE} = +1mA	2/3 x V _L			V
	V _{OL}	I _{SINK} = -1mA			0.4	
$\overline{\text{OFFVBUS}}$, SHDN Input Voltage	V _{IH}		2/3 x V _L			V
	V _{IL}				0.4	
Input Leakage Current	I _{LKG}	$\overline{\text{OFFVBUS}}$, SHDN = GND or V _L			±1	μA
V_{BUS} OUTPUT VOLTAGE: DEVICE A CONFIGURED						
V _{BUS} Output Voltage		I _{LOAD} = 0 to 8mA, C _{LOAD} = 1μF, $\overline{\text{OFFVBUS}} = V_L$, ID_IN = GND	4.63		5.25	V
		No load, C _{LOAD} = 1μF, $\overline{\text{OFFVBUS}} = V_L$, ID_IN = GND		4.8		
V _{BUS} Leakage Voltage		$\overline{\text{OFFVBUS}} = \text{GND}$			200	mV
V _{BUS} Sink Current		$\overline{\text{OFFVBUS}} = \text{GND}$, V _{BUS} = +6.0V			150	μA

±15kV ESD-Protected USB On-the-Go Charge Pump and Comparators in UCSP

MAX3355E

ELECTRICAL CHARACTERISTICS (continued)

(V_{CC} = +2.6V to +5.5V, V_L = +1.65V to V_{CC}, C₁ = 0.1μF, V_{CC} decoupled with 1μF capacitor to GND, V_L decoupled with 0.1μF capacitor to GND, C_{LOAD} = 1μF (min), ESR_{LOAD} = 1Ω (max), T_A = T_{MIN} to T_{MAX}. Typical values are at V_{CC} = +3.0V, V_L = 1.8V, T_A = +25°C, unless otherwise noted.) (Notes 1, 2)

PARAMETER	SYMBOL	CONDITIONS	MIN	TYP	MAX	UNITS
V _{BUS} Source Current		$\overline{\text{OFFV}}_{\text{BUS}} = V_L, \text{ID_IN} = \text{GND}$	8			mA
V _{BUS} Short-Circuit Current Limit		V _{BUS} shorted to GND			200	mA
V _{BUS} Output Ripple		I _{LOAD} = 8mA, C _{LOAD} = 1μF, $\overline{\text{OFFV}}_{\text{BUS}} = V_L, \text{ID_IN} = \text{GND}$ (Note 3)		100		mV
Charge-Pump Switching Frequency				500		kHz
V _{BUS} Input Impedance	R _{INVBUS}	$\overline{\text{OFFV}}_{\text{BUS}} = \text{GND}$ or $\overline{\text{SHDN}} = \text{GND}$	40		100	kΩ
LOAD DETECTION V_{BUS} OUTPUT VOLTAGE						
V _{BUS} Output Voltage		C _{LOAD} = 20μF, $\overline{\text{OFFV}}_{\text{BUS}} = V_L, \text{ID_IN} = V_{\text{CC}}, \text{I}_{\text{BUS}}$ source on-time = t _{VBUSCHRG}	2.1			V
		C _{LOAD} = 95μF, $\overline{\text{OFFV}}_{\text{BUS}} = V_L, \text{ID_IN} = V_{\text{CC}}, \text{I}_{\text{BUS}}$ source on-time = t _{VBUSCHRG}			1.9	
V _{BUS} Source Current		$\overline{\text{OFFV}}_{\text{BUS}} = V_L, \text{ID_IN} = V_{\text{CC}}$ (Note 4)	450	600	850	μA
V _{BUS} Current Gate Time	t _{VBUSCHRG}	$\overline{\text{OFFV}}_{\text{BUS}} = V_L, \text{ID_IN} = V_{\text{CC}}$, Device B (Note 4)	155 (max)	105	56 (min)	ms
V_{BUS} COMPARATOR						
V _{BUS} Valid Comparator Threshold	V _{THVBUSVLD}	V _{BUS} rising	4.4	4.55	4.63	V
V _{BUS} Valid Comparator Hysteresis				20		mV
Session Valid Comparator Threshold	V _{THSESVLD}		1.12	1.4	1.68	V
Session Valid Comparator Hysteresis				15		mV
B-Session End Comparator Threshold	V _{THSESEND}		0.4	0.5	0.6	V
B-Session End Comparator Hysteresis				30		mV
Shutdown Comparator	V _{TH,SHDN}		0.8		2.4	V
ID_IN						
ID_IN Voltage Input for Device B			2/3 x V _{CC}			V
ID_IN Voltage Input for Device A					0.4	V
ID_IN Input Impedance			150	200	250	kΩ
ESD PROTECTION (ID_IN, V_{BUS})						
Human Body Model				±15		kV
IFC 1000-4-2 Air-Gap Discharge				±15		kV
IFC 1000-4-2 Contact Discharge				±8		kV

$\pm 15\text{kV}$ ESD-Protected USB On-the-Go Charge Pump and Comparators in UCSP

TIMING CHARACTERISTICS

($V_{CC} = +2.6\text{V}$ to $+5.5\text{V}$, $V_L = +1.65\text{V}$ to V_{CC} , $C_1 = 0.1\mu\text{F}$, V_{CC} decoupled with $1\mu\text{F}$ capacitor to GND, V_L decoupled with $0.1\mu\text{F}$ capacitor to GND, $C_{LOAD} = 1\mu\text{F}$ (min), $ESR_{LOAD} = 1\Omega$ (max), $T_A = T_{MIN}$ to T_{MAX} . Typical values are at $V_{CC} = +3.0\text{V}$, $V_L = 1.8\text{V}$, $T_A = +25^\circ\text{C}$, unless otherwise noted.) (Notes 1, 2)

PARAMETER	SYMBOL	CONDITIONS	MIN	TYP	MAX	UNITS
V_{BUS} Rise Time		0 to 4.4V, $C_{LOAD} = 1\mu\text{F}$, $I_{LOAD} = 8\text{mA}$			100	ms
OFFV _{BUS} Propagation Delay				6		μs
Comparator Propagation Delay				3		μs
Time to Exit Shutdown				50		μs
Time to Shutdown				1		μs
ID_OUT Rise Time		$C_{ID_OUT} = 50\text{pF}$		10		ns
ID_OUT Fall Time		$C_{ID_OUT} = 50\text{pF}$		10		ns

Note 1: Limits are 100% production tested at $+25^\circ\text{C}$. Limits over temperature are guaranteed by design.

Note 2: All currents out of the device are positive; all currents into the device are negative. All voltages are referenced to device ground unless otherwise specified.

Note 3: The ripple voltage is strongly correlated to the bus capacitance and its ESR.

Note 4: The V_{BUS} current source and current gate time vary together with process and temperature such that the resulting V_{BUS} pulse is guaranteed to drive a $<13\mu\text{F}$ load to a voltage $>2.0\text{V}$, and to drive a $>96\mu\text{F}$ load to a voltage $<2.2\text{V}$.

Typical Operating Characteristics

(V_{CC} , $V_L = +3.3\text{V}$, $C_1 = 0.1\mu\text{F}$, V_{CC} decoupled with $1\mu\text{F}$ capacitor to GND, V_L decoupled with $0.1\mu\text{F}$ capacitor to GND, $C_{LOAD} = 1\mu\text{F}$ min, $ESR_{LOAD} = 1\Omega$ max, $T_A = +25^\circ\text{C}$, unless otherwise noted.)

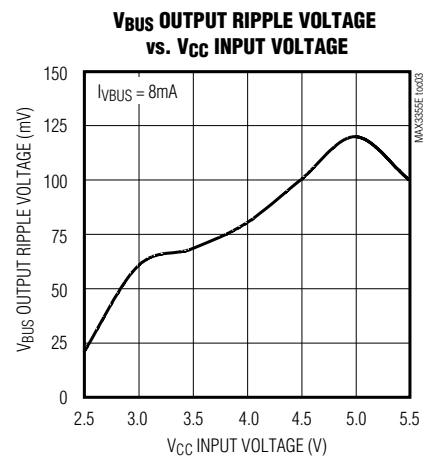
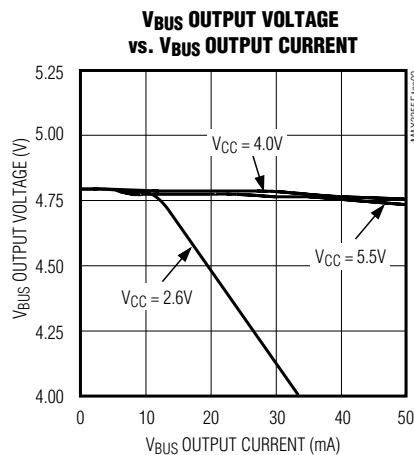
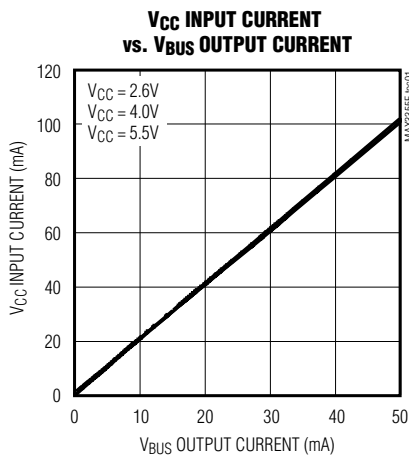

±15kV ESD-Protected USB On-the-Go Charge Pump and Comparators in UCSP

MAX3355E

Typical Operating Characteristics (continued)

(V_{CC} , $V_L = +3.3V$, $C_1 = 0.1\mu F$, V_{CC} decoupled with $1\mu F$ capacitor to GND, V_L decoupled with $0.1\mu F$ capacitor to GND, $C_{LOAD} = 1\mu F$ min, $ESR_{LOAD} = 1\Omega$ max, $T_A = +25^\circ C$, unless otherwise noted.)

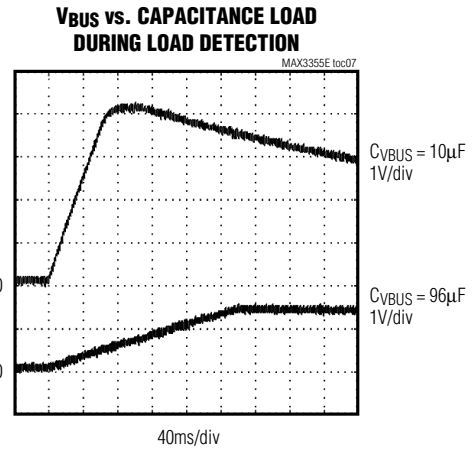
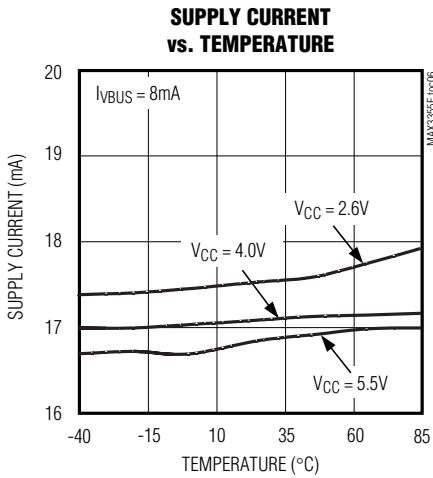
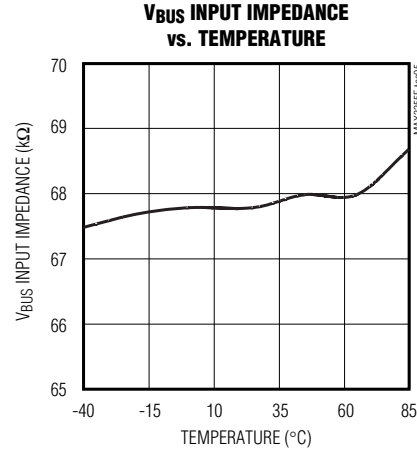
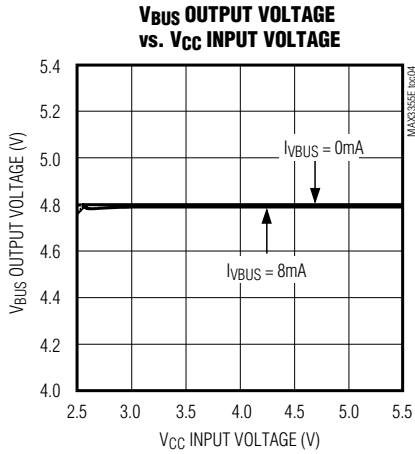

$\pm 15kV$ ESD-Protected USB On-the-Go Charge Pump and Comparators in UCSP

Pin Description

PIN		NAME	FUNCTION
UCSP	TSSOP		
A1	2	V _{CC}	Power Supply. +2.6V to +5.5V input supply. Bypass V _{CC} to GND with a 1 μ F capacitor.
A2	3	ID_OUT	Device ID Output. Output of ID_IN level translated to V _L .
A3	5	STATUS1	Status Output 1. Provides output voltage detection for use during HNP handshaking (Tables 1 and 2).
A4	6	STATUS2	Status Output 2. Provides output voltage detection for use during HNP handshaking (Tables 1 and 2).
B1	1	V _{BUS}	USB Supply. V _{BUS} provides a nominal +5.0V output when ID_IN is low and $\overline{\text{OFFVBUS}}$ is high. V _{BUS} is lower than +2.1V when ID_IN is open or a load greater than 96.5 μ F is sensed. V _{BUS} can be backdriven to +6.0V without any consequence. Bypass V _{BUS} to GND with a 1 μ F capacitor.
B2	4	$\overline{\text{OFFVBUS}}$	V _{BUS} Off. Turns the internal charge pump providing V _{BUS} on and off.
B3	11	$\overline{\text{SHDN}}$	Shutdown. Connect $\overline{\text{SHDN}}$ to GND to enter shutdown and reduce supply current to less than 1 μ A. Connect $\overline{\text{SHDN}}$ to V _L for normal operation.
B4	9	V _L	Logic Supply. V _L sets the logic output high voltage and logic input high threshold. V _L must be between +1.65V and V _{CC} .
C1	14	C+	Charge-Pump Positive Connection
C2	13	C-	Charge-Pump Negative Connection
C3	12	GND	Ground
C4	10	ID_IN	Device ID. ID_IN is internally pulled up to V _{CC} . Leave ID_IN open for device B and connect ID_IN to GND for device A.
—	7, 8	N.C.	No Connection

Typical Application Circuit

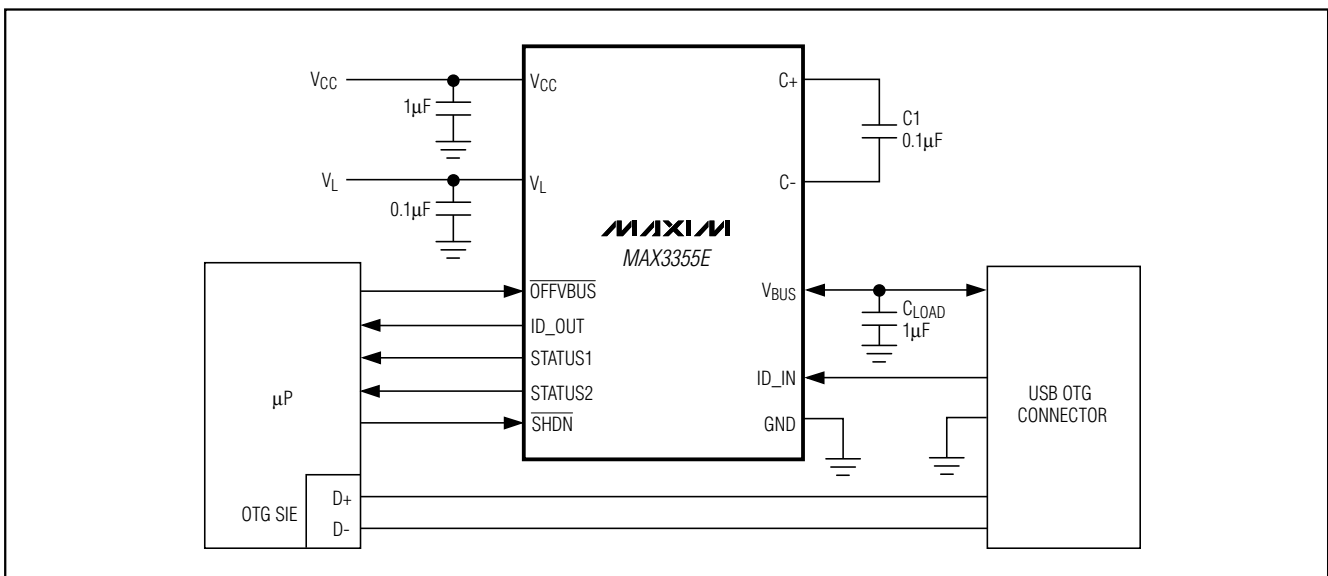

±15kV ESD-Protected USB On-the-Go Charge Pump and Comparators in UCSP

Detailed Description

USB OTG is an emerging USB standard that enables devices to talk in a peer-to-peer manner on a USB bus. OTG allows peripherals and mobile devices such as PDAs, cellular phones, and digital cameras to be attached directly to one another without requiring a PC host.

The MAX3355E integrates a charge pump and comparators to enable a system with an integrated USB OTG dual-role transceiver to function as a USB OTG dual-role device. The MAX3355E's internal charge pump supplies V_{BUS} power and signaling as defined in *On-the-Go Supplement: USB 2.0, Revision 1.0*. The MAX3355E's internal level-detection comparators monitor important V_{BUS} voltages needed to support SRP and HNP.

Table 1. Status Bit Significance

STATUS1	STATUS2	SIGNIFICANCE
0	0	V _{BUS} < V _{THSESEND}
1	0	V _{THSESEND} < V _{BUS} < V _{THSESVLD}
0	1	V _{THSESVLD} < V _{BUS} < V _{THVBUSVLD}
1	1	V _{BUS} > V _{THVBUSVLD}

Table 2. Status Bit Shutdown Functionality (SHDN = GND)

STATUS1	STATUS2	SIGNIFICANCE
0	1	V _{BUS} < V _{TH,SHDN}
0	0	V _{BUS} > V _{TH,SHDN}

Table 3. Device ID

ID_IN	ID_OUT	CONFIGURATION
0	0	Device A
Open	V _L	Device B

Table 4. Function Select

SHDN	OFFVBUS	ID_IN	V _{BUS}	CHARGE PUMP	COMPARATORS
0	X	X	R _{INVBUS}	Inactive	Inactive
1	0	X	R _{INVBUS}	Inactive	Active
1	1	0	5V	Active	Active
1	1	1	R _{INVBUS} (Note 5)	Inactive	Active

Note: The 600μA current source is supplied for t_{VBUSCHRG} (see the Current Generator section).

Charge Pump

The MAX3355E provides power for the V_{BUS} line using an internal charge pump. The charge pump provides an OTG-compliant output on V_{BUS} while sourcing 8mA load current. The charge pump can be powered from voltages between +2.6V and +5.5V. A 0.1μF flying capacitor, connected between C+ and C-, and a 1μF (min) decoupling reservoir capacitor on V_{BUS} are required for proper operation.

The charge pump is active if $\overline{\text{OFFVBUS}}$ is connected to V_L and the MAX3355E is configured as device A (ID_IN connected to GND). To minimize V_{BUS} ripple, select a reservoir capacitor value between 1μF and 6.8μF. The charge-pump output is protected from short-circuit conditions on V_{BUS} by an internal current clamp that limits the V_{BUS} current to 200mA.

Current Generator

An internal current generator injects up to 600μA of current onto the V_{BUS} line. The current generator is stable over the supply voltage variation. The current generator is connected to V_{BUS} when $\overline{\text{OFFVBUS}}$ and SHDN are 1 and ID_IN is open. It remains connected for t_{VBUSCHRG} or until the V_{BUS} line voltage exceeds the lower of V_{CC} and 4.82V.

Comparators

The MAX3355E contains internal comparators for monitoring the V_{BUS} voltage. The status of V_{BUS} is summarized in two status outputs: STATUS1 and STATUS2. The status outputs can be used to negotiate for the USB OTG bus. The V_{BUS} status is conveyed according to Table 1. While in shutdown mode, the STATUS2 output can be used to indicate V_{BUS} voltage (Table 2).

Device ID

Configure the MAX3355E as device A by connecting ID_IN to GND and as device B by leaving ID_IN open (Table 3). ID_IN is level translated to V_L and provided as an output at ID_OUT. V_L sets the logic output high level. ID_IN is internally pulled up to V_{CC}.

±15kV ESD-Protected USB On-the-Go Charge Pump and Comparators in UCSP

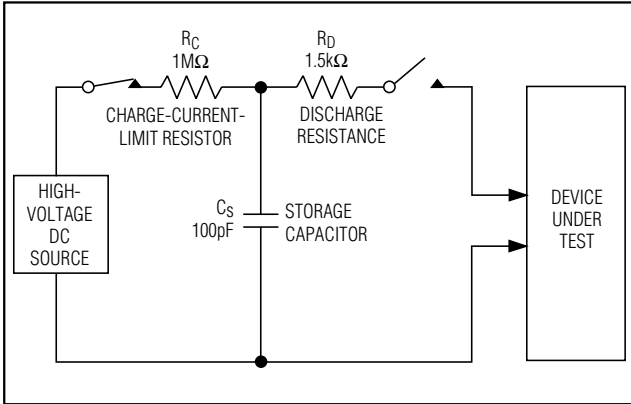

Figure 1. Human Body ESD Test Model

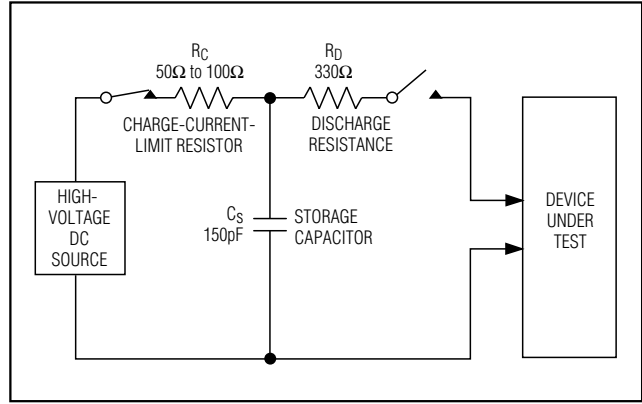

Figure 3. IEC 1000-4-2 ESD Test Model

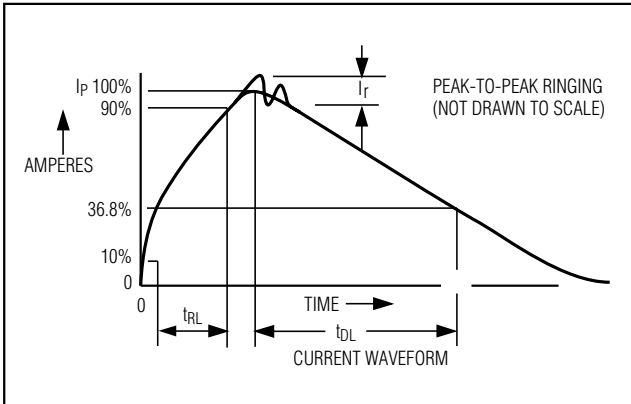

Figure 2. Human Body Current Waveform

have extra protection against static electricity to protect the device up to ±15kV. For ±15kV protection on V_{BUS}, a 1μF capacitor must be connected from V_{BUS} to GND as close to the device as possible. The ESD structures withstand high ESD in all states—normal operation, shutdown, and powered down. ESD protection can be tested in various ways. The ID_IN input and V_{BUS} are characterized for protection to the following limits:

- 1) ±15kV using the Human Body Model
- 2) ±8kV using the IEC 1000-4-2 Contact Discharge method
- 3) ±15kV using the IEC 1000-4-2 Air-Gap Discharge method

ESD performance depends on a variety of conditions. Contact Maxim for a reliability report that documents test setup, test methodology, and test results.

OFFVBUS

Connect $\overline{\text{OFFVBUS}}$ to GND to disable V_{BUS} and the charge pump (Table 4). For normal V_{BUS} operation, connect OFFVBUS to VL. When $\overline{\text{OFFVBUS}} = \text{GND}$, V_{BUS} impedance is between 40kΩ to 100kΩ as defined in *On-the-Go Supplement: USB 2.0, Revision 1.0*.

SHDN

The MAX3355E shutdown mode reduces supply current to less than 1μA. To enter shutdown mode, connect SHDN to GND. Shutdown mode disables the charge pump and comparators (Table 4). While in shutdown mode, the STATUS1 output defaults to logic 0 and STATUS2 indicates V_{BUS}. During shutdown, if V_{BUS} is externally driven above V_{TH,SHDN} (defined in the *Comparators* section), the MAX3355E sinks current from V_{CC}.

Applications Information

±15kV ESD Protection

To protect the MAX3355E against ESD, ID_IN and V_{BUS}

Human Body Model

Figure 1 shows the Human Body Model and Figure 2 shows the current waveform it generates when discharged into a low impedance. This model consists of a 100pF capacitor charged to the ESD voltage of interest, which is then discharged into the test device through a 1.5kΩ resistor.

IEC 1000-4-2

The IEC 1000-4-2 standard covers ESD testing and performance of finished equipment. It does not specifically refer to integrated circuits. The MAX3355E helps the user design equipment that meets Level 4 of IEC 1000-4-2, without the need for additional ESD-protection components. The major difference between tests done using the Human Body Model and IEC 1000-4-2 is a higher peak current in IEC 1000-4-2. This occurs because series resistance is lower in the IEC 1000-4-2 model. Hence, the ESD withstand voltage measured to

±15kV ESD-Protected USB On-the-Go Charge Pump and Comparators in UCSP

MAX3355E

IEC 1000-4-2 is generally lower than that measured using the Human Body Model. Figure 3 shows the IEC 1000-4-2 model. The Air-Gap Discharge test involves approaching the device with a charged probe. The contact-discharge method connects the probe to the device before the probe is energized.

Machine Model

The Machine Model for ESD tests all pins using a 200pF storage capacitor and zero discharge resistance. Its objective is to emulate the stress caused by contact that occurs with handling and assembly during manufacturing. All pins require this protection during manufacturing. After PC board assembly, the Machine Model is less relevant to I/O ports.

Layout Considerations

The MAX3355E charge-pump switching frequency makes proper layout important to ensure stability and maintain the output voltage under all loads. For best performance, minimize the distance between the capacitors and the MAX3355E.

UCSP Applications Information

For the latest application details on UCSP construction, dimensions, tape-carrier information, printed circuit board techniques, bump-pad layout, and recommended reflow temperature profile, as well as the latest information on reliability testing results, refer to Maxim Application Note: *UCSP-A Wafer-Level Chip-Scale Package* available on Maxim's web site at www.maxim-ic.com/ucsp.

Pin Configurations

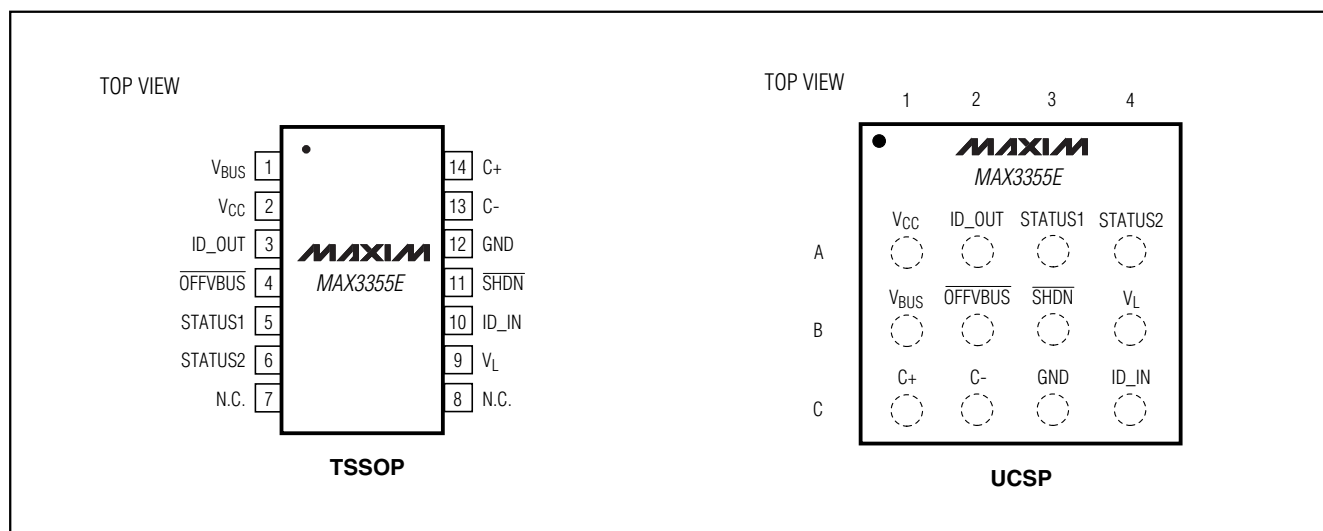

Chip Information

TRANSISTOR COUNT: 1601
PROCESS: BiCMOS

±15kV ESD-Protected USB On-the-Go Charge Pump and Comparators in UCSP

Package Information

(The package drawing(s) in this data sheet may not reflect the most current specifications. For the latest package outline information go to www.maxim-ic.com/packages.)

TOP VIEW

COMMON DIMENSIONS	
A	0.60±0.05
A1	0.27±0.03
A2	0.33 REF.
b	∅0.37 BASIC
D1	1.00 BASIC
E1	1.50 BASIC
e	0.50 BASIC
SD	0.00 BASIC
SE	0.25 BASIC

PKG. CODE	VARIABLE DIMENSIONS		DEPOPULATED SOLDER BALLS
	D	E	
B12-1	1.54±0.05	2.02±0.05	NONE
B12-2	1.54±0.05	2.02±0.05	B3
B12-3	1.54±0.05	2.12±0.05	NONE
B12-4	1.54±0.05	2.02±0.05	B2, B3
B12-5	1.64±0.05	2.12±0.05	B2
B12-6	1.64±0.05	2.12±0.05	B3
B12-7	1.54±0.05	2.02±0.05	B1, B3
B12-8	1.54±0.05	2.02±0.05	B2
B12-9	1.54±0.05	2.12±0.05	B2, B3

NOTES:

- ALL DIMENSIONS ARE IN MILLIMETERS.
- PRODUCT MARKING: NUMBER OF CHARACTERS AND LINES VARY PER PRODUCT.

SIDE VIEW

BOTTOM VIEW

MAXIM

PROPRIETARY INFORMATION

TITLE
PACKAGE OUTLINE, 4x3 UCSP

APPROVAL	DOCUMENT CONTROL NO. 21-0104	REV. E	1/1
----------	---------------------------------	-----------	-----

12L UCSP 4x3.EPS

±15kV ESD-Protected USB On-the-Go Charge Pump and Comparators in UCSP

Package Information (continued)

(The package drawing(s) in this data sheet may not reflect the most current specifications. For the latest package outline information go to www.maxim-ic.com/packages.)

MAX3355E

TSSOP4.40mm:EPS

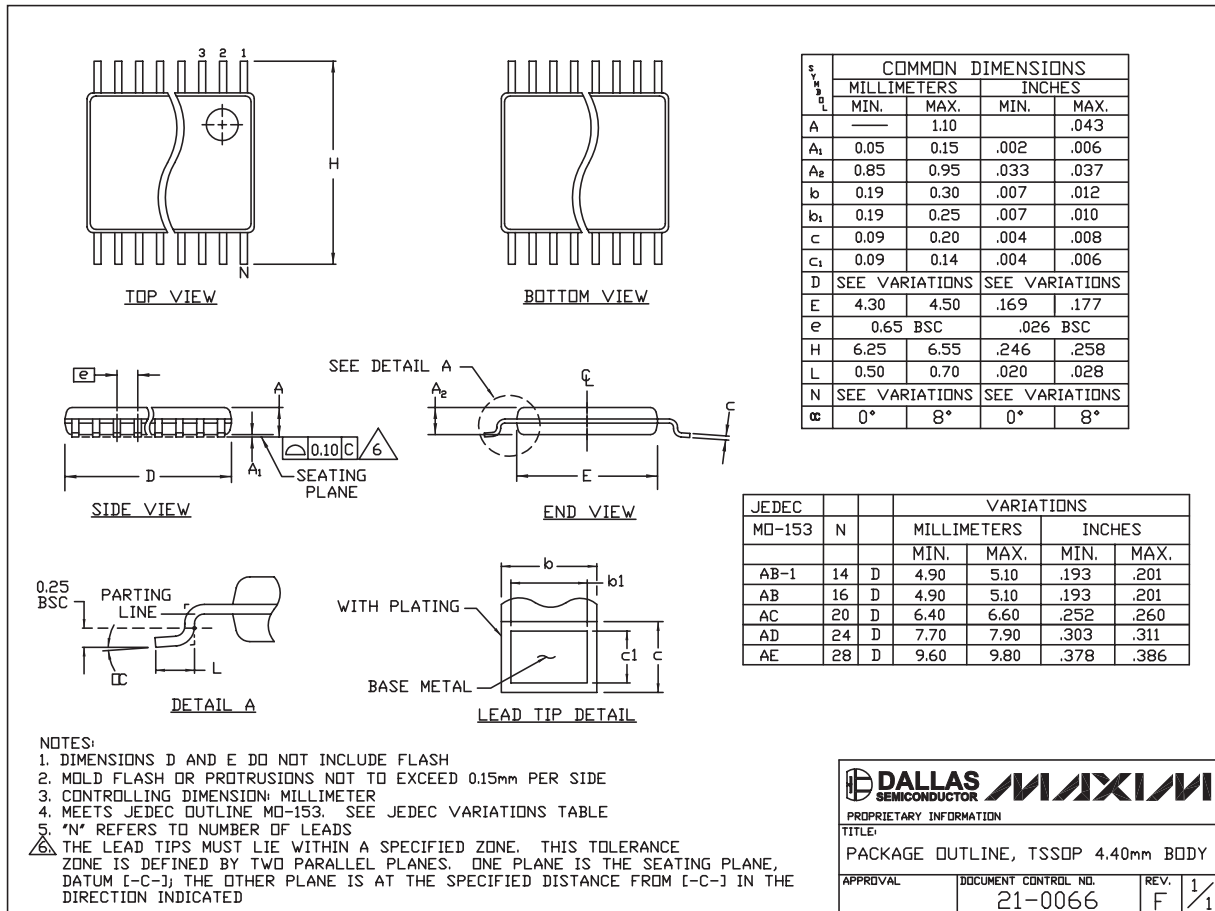

Maxim cannot assume responsibility for use of any circuitry other than circuitry entirely embodied in a Maxim product. No circuit patent licenses are implied. Maxim reserves the right to change the circuitry and specifications without notice at any time.

Maxim Integrated Products, 120 San Gabriel Drive, Sunnyvale, CA 94086 408-737-7600 _____ 11