

**480-OUTPUT TFT-LCD SOURCE DRIVER
(COMPATIBLE WITH 64-GRAY SCALES)****DESCRIPTION**

The μ PD16772 is a source driver for TFT-LCDs capable of dealing with displays with 64-gray scales. Data input is based on digital input configured as 6 bits by 6 dots (2 pixels), which can realize a full-color display of 260,000 colors by output of 64 values γ -corrected by an internal D/A converter and 5-by-2 external power modules. Because the output dynamic range is as large as $V_{SS2} + 0.1$ V to $V_{DD2} - 0.1$ V, level inversion operation of the LCD's common electrode is rendered unnecessary. Also, to be able to deal with dot-line inversion, n-line inversion and column line inversion when mounted on a single side, this source driver is equipped with a built-in 6-bit D/A converter circuit whose odd output pins and even output pins respectively output gray scale voltages of differing polarity. Assuring a clock frequency of 45 MHz when driving at 2.3 V, this driver is applicable to UXGA-standard TFT-LCD panels.

FEATURES

- CMOS level input (2.3 to 3.6 V)
- 480 outputs
- Input of 6 bits (gradation data) by 6 dots
- Capable of outputting 64 values by means of 5-by-2 external power modules (10 units) and a D/A converter (R-DAC)
- Output dynamic range : $V_{SS2} + 0.1$ V to $V_{DD2} - 0.1$ V
- High-speed data transfer : $f_{CLK} = 45$ MHz (internal data transfer speed when operating at $V_{DD1} = 2.3$ V)
- Apply for dot-line inversion, n-line inversion and column line inversion
- Output voltage polarity inversion function (POL)
- Display data inversion function (POL21/22)
- Current consumption reduction function (LPC, Bcont)
- Logic power supply voltage (V_{DD1}) : 2.3 to 3.6 V
- Driver power supply voltage (V_{DD2}) : 8.5 V \pm 0.5 V

ORDERING INFORMATION

Part Number	Package
μ PD16772N-xxx	TCP (TAB package)

Remark The TCP's external shape is customized. To order the required shape, so please contact one of our sales representatives.

The information in this document is subject to change without notice. Before using this document, please confirm that this is the latest version.
Not all devices/types available in every country. Please check with local NEC representative for availability and additional information.

1. BLOCK DIAGRAM

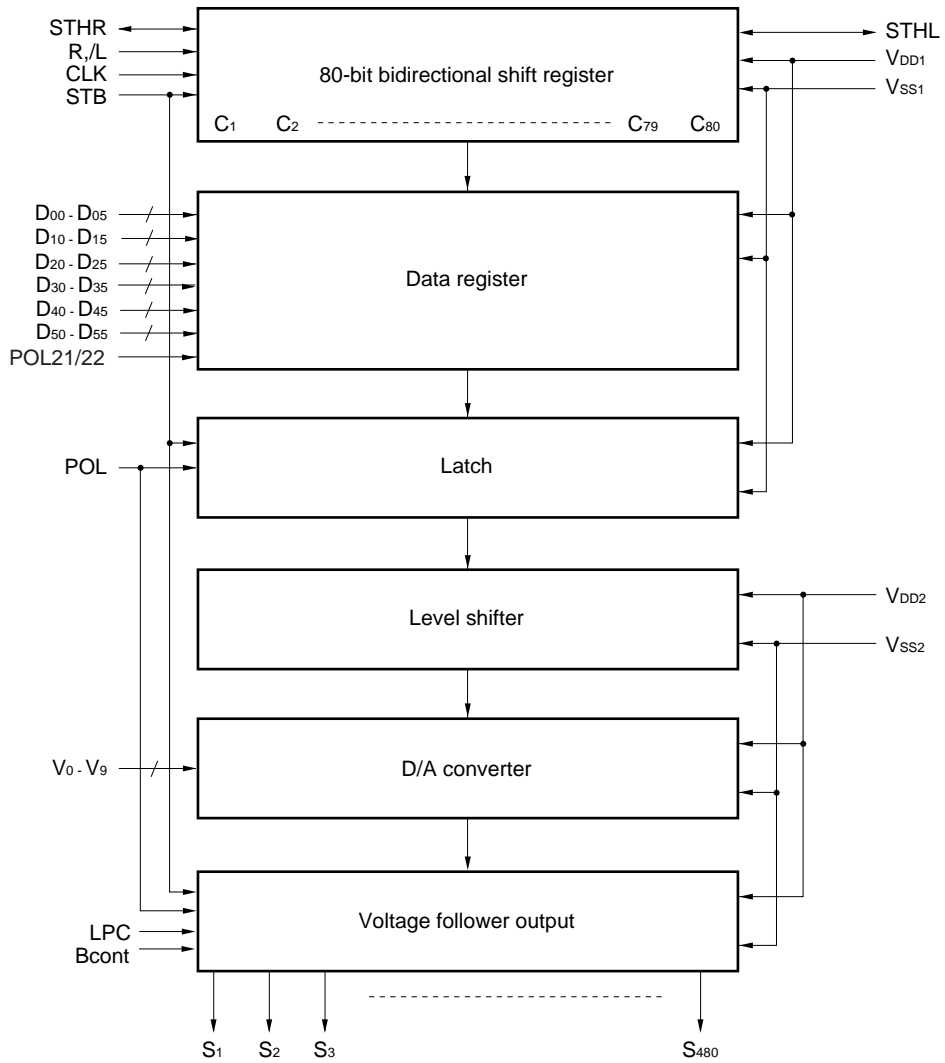

Remark /xxx indicates active low signal.

2. RELATIONSHIP BETWEEN OUTPUT CIRCUIT AND D/A CONVERTER

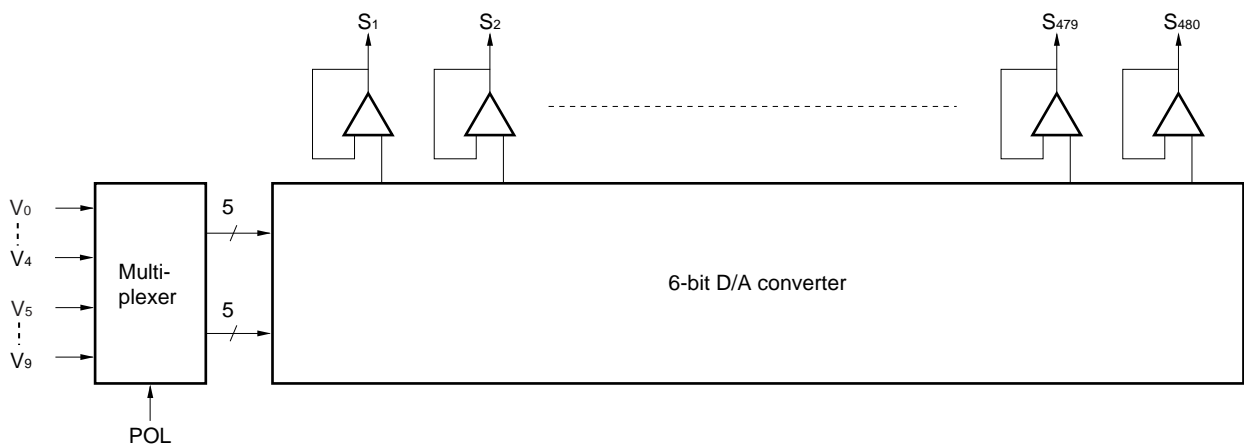

3. PIN CONFIGURATION (μPD16772N-xxx: TCP (TAB package))

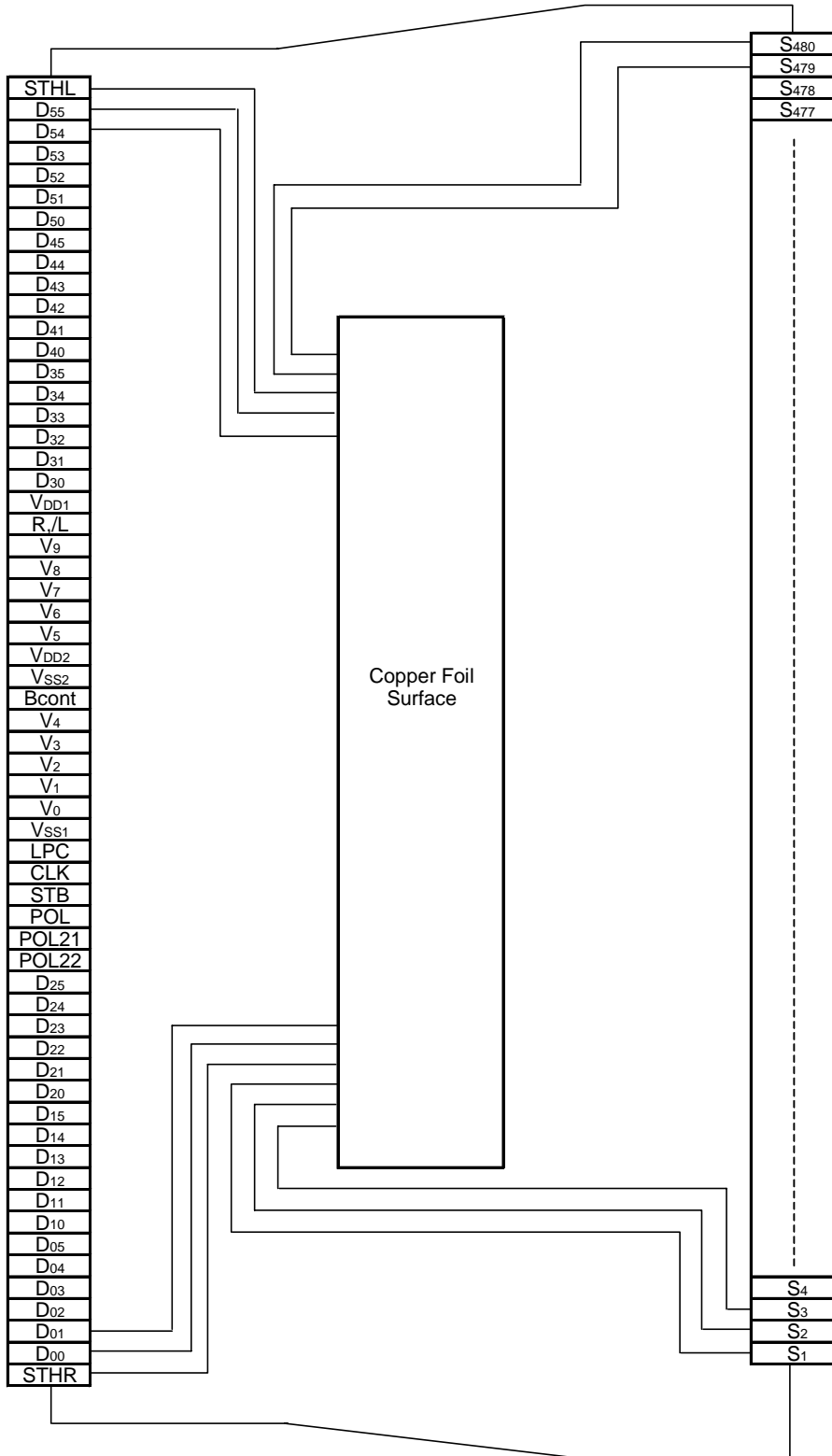

Remark This figure does not specify the TCP package.

4. PIN FUNCTIONS

Pin Symbol	Pin Name	Description
S ₁ to S ₄₈₀	Driver output	The D/A converted 64-gray-scale analog voltage is output.
D ₀₀ to D ₀₅	Display data input	The display data is input with a width of 36 bits, viz., the gray scale data (6 bits) by 6 dots (2 pixels). D _{x0} : LSB, D _{x5} : MSB
D ₁₀ to D ₁₅		
D ₂₀ to D ₂₅		
D ₃₀ to D ₃₅		
D ₄₀ to D ₄₅		
D ₅₀ to D ₅₅		
R,/L	Shift direction control input	These refer to the start pulse I/O pins when driver ICs are connected in cascade. The shift directions of the shift registers are as follows. R,/L = H: STHR input, S ₁ → S ₄₈₀ , STHL output R,/L = L: STHL input, S ₄₈₀ → S ₁ , STHR output
STHR	Right shift start pulse input/output	These refer to the start pulse I/O pins when driver ICs are connected in cascade. Fetching of display data starts when H is read at the rising edge of CLK. R,/L = H (right shift): STHR input, STHL output R,/L = L (left shift): STHL input, STHR output The start pulse width (H level) for next-level drivers is 1CLK.
STHL	Left shift start pulse input/output	
CLK	Shift clock input	Refers to the shift register's shift clock input. The display data is incorporated into the data register at the rising edge. At the rising edge of the 80th clock after the start pulse input, the start pulse output reaches the high level, thus becoming the start pulse of the next-level driver. If 82 clock pulses are input after input of the start pulse, input of display data is halted automatically. The contents of the shift register are cleared at the STB's rising edge.
STB	Latch input	The contents of the data register are transferred to the latch circuit at the rising edge. And, at the falling edge, the gray scale voltage is supplied to the driver. It is necessary to ensure input of one pulse per horizontal period.
POL	Polarity input	POL = L: The S _{2n-1} output uses V ₀ to V ₄ as the reference supply. The S _{2n} output uses V ₅ to V ₉ as the reference supply. POL = H: The S _{2n-1} output uses V ₅ to V ₉ as the reference supply. The S _{2n} output uses V ₀ to V ₄ as the reference supply. S _{2n-1} indicates the odd output: and S _{2n} indicates the even output. Input of the POL signal is allowed the setup time(t _{POL-STB}) with respect to STB's rising edge.
POL21, POL22	Data inversion input	Data inversion can invert when display data is loaded. POL21/22 = H : Data inversion loads display data after inverting it. POL21/22 = L : Data inversion does not invert input data. POL21: D ₀₀ to D ₀₅ , D ₁₀ to D ₁₅ , D ₂₀ to D ₂₅ POL22: D ₃₀ to D ₃₅ , D ₄₀ to D ₄₅ , D ₅₀ to D ₅₅
LPC	Low power control input	The current consumption of V _{DD2} is lowered by controlling the constant current source of the output amplifier. This pin is pulled up to the V _{DD1} power supply inside the IC. For details, see 9. CURRENT CONSUMPTION REDUCTION FUNCTION.
Bcont	Bias control	This pin can be used to finely control the bias current inside the output amplifier. When this fine-control function is not required, leave this pin open. For details, see 9. CURRENT CONSUMPTION REDUCTION FUNCTION.
V ₀ to V ₉	γ-corrected power supplies	Input the γ-corrected power supplies from outside by using operational amplifier. Make sure to maintain the following relationships. During the gray scale voltage output, be sure to keep the gray scale level power supply at a constant level. V _{DD2} - 0.1 V > V ₀ > V ₁ > V ₂ > V ₃ > V ₄ > 0.5 V _{DD2} > V ₅ > V ₆ > V ₇ > V ₈ > V ₉ > V _{SS2} + 0.1 V
V _{DD1}	Logic power supply	2.3 to 3.6 V
V _{DD2}	Driver power supply	8.5 V ± 0.5 V
V _{SS1}	Logic ground	Grounding
V _{SS2}	Driver ground	Grounding

- Cautions**
1. The power start sequence must be V_{DD1} , logic input, and V_{DD2} & V_0 to V_9 in that order. Reverse this sequence to shut down (Simultaneous power application to V_{DD2} and V_0 to V_9 is possible.).
 2. To stabilize the supply voltage, please be sure to insert a $0.1 \mu\text{F}$ bypass capacitor between $V_{DD1}-V_{SS1}$ and $V_{DD2}-V_{SS2}$. Furthermore, for increased precision of the D/A converter, insertion of a bypass capacitor of about $0.01 \mu\text{F}$ is also advised between the γ -corrected power supply terminals ($V_0, V_1, V_2, \dots, V_9$) and V_{SS2} .

5. RELATIONSHIP BETWEEN INPUT DATA AND OUTPUT VOLTAGE VALUE

The μPD16772 incorporates a 6-bit D/A converter whose odd output pins and even output pins output respectively gray scale voltages of differing polarity with respect to the LCD's counter electrode (common electrode) voltage. The D/A converter consists of ladder resistors and switches.

The ladder resistors (r0 to r62) are designed so that the ratio of LCD panel γ-compensated voltages to V_{0'} to V_{63'} and V_{0''} to V_{63''} is almost equivalent. For the 2 sets of five γ-compensated power supplies, V₀ to V₄ and V₅ to V₉, respectively, input gray scale voltages of the same polarity with respect to the common voltage. When fine gray scale voltage precision is not necessary, there is no need to connect a voltage follower circuit to the γ-compensated power supplies V₁ to V₃ and V₆ to V₈.

Figure 5-1 shows the relationship between the driving voltages such as liquid-crystal driving voltages V_{DD2} and V_{SS2}, common electrode potential V_{COM}, and γ-corrected voltages V₀ to V₉ and the input data. Be sure to maintain the voltage relationships of V_{DD2} - 0.1 V > V₀ > V₁ > V₂ > V₃ > V₄ > 0.5 V_{DD2} > V₅ > V₆ > V₇ > V₈ > V₉ > V_{SS2} + 0.1 V

Figures 5-2 and 5-3 show the relationship between the input data and the output voltage and the resistance values of the resistor strings.

Figure 5-1. Relationship between Input Data and γ-corrected Power Supplies

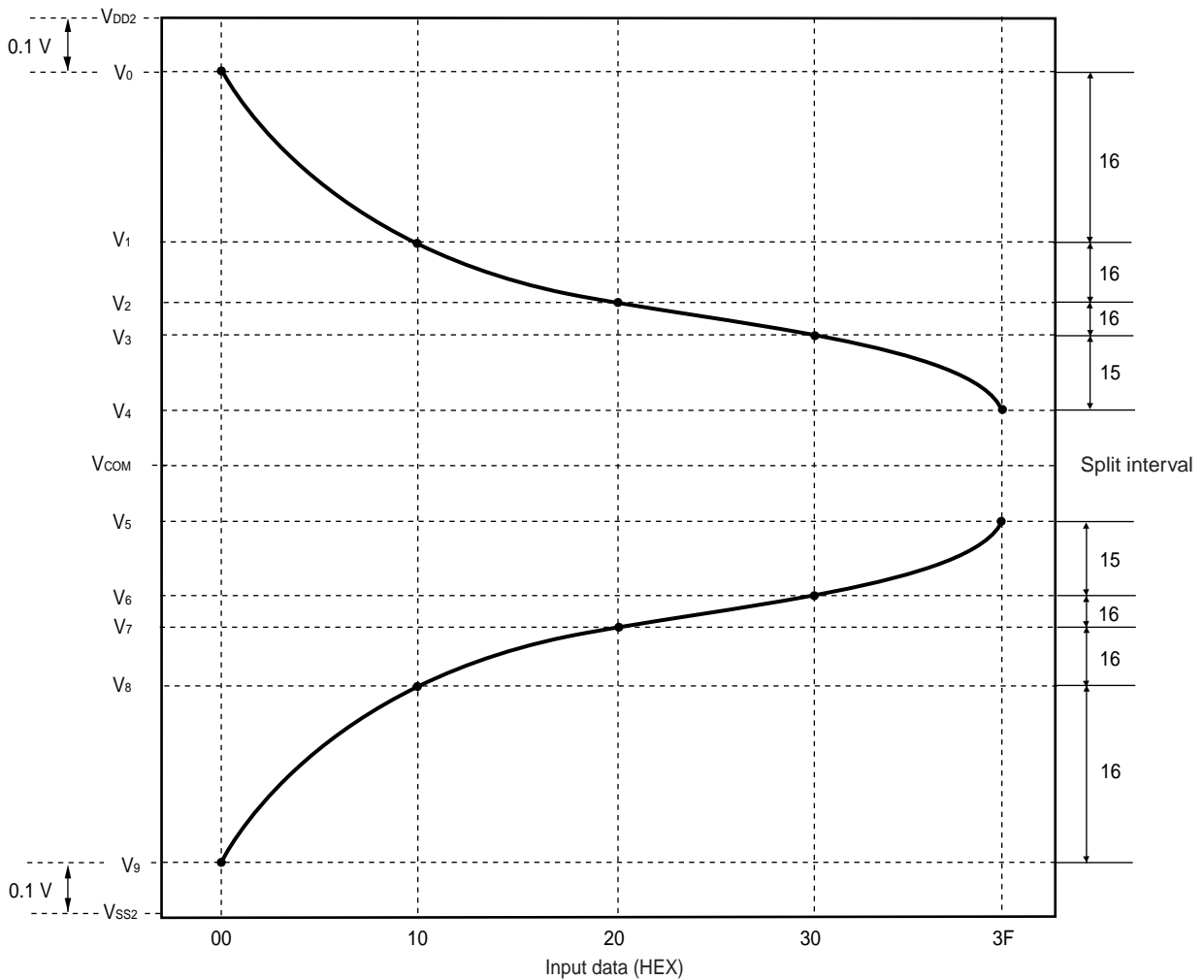
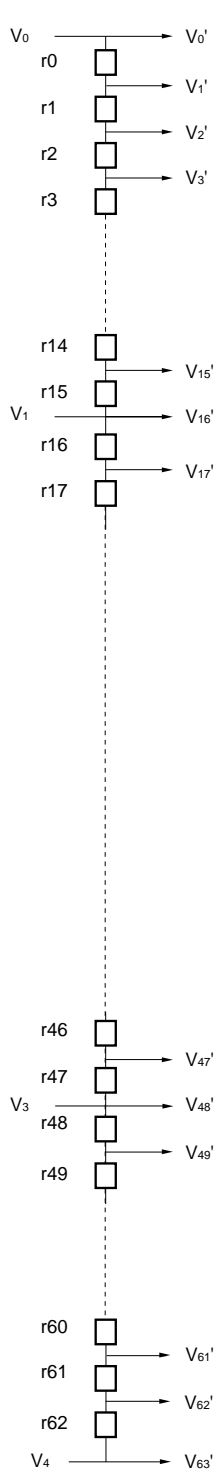

Figure 5-2. Relationship between Input Data and Output Voltage

$$V_{DD2} - 0.2\text{ V} > V_0 > V_1 > V_2 > V_3 > V_4 > 0.5 V_{DD2}, \text{ POL21/22} = \text{L}$$



Data	DX5	DX4	DX3	DX2	DX1	DX0	Output voltage	
00H	0	0	0	0	0	0	V0'	V0
01H	0	0	0	0	0	1	V1'	$V1+(V0-V1)x$ 7250 / 8050
02H	0	0	0	0	1	0	V2'	$V1+(V0-V1)x$ 6500 / 8050
03H	0	0	0	0	1	1	V3'	$V1+(V0-V1)x$ 5800 / 8050
04H	0	0	0	1	0	0	V4'	$V1+(V0-V1)x$ 5150 / 8050
05H	0	0	0	1	0	1	V5'	$V1+(V0-V1)x$ 4550 / 8050
06H	0	0	0	1	1	0	V6'	$V1+(V0-V1)x$ 4000 / 8050
07H	0	0	0	1	1	1	V7'	$V1+(V0-V1)x$ 3450 / 8050
08H	0	0	1	0	0	0	V8'	$V1+(V0-V1)x$ 2950 / 8050
09H	0	0	1	0	0	1	V9'	$V1+(V0-V1)x$ 2450 / 8050
0AH	0	0	1	0	1	0	V10'	$V1+(V0-V1)x$ 2050 / 8050
0BH	0	0	1	0	1	1	V11'	$V1+(V0-V1)x$ 1650 / 8050
0CH	0	0	1	1	0	0	V12'	$V1+(V0-V1)x$ 1300 / 8050
0DH	0	0	1	1	0	1	V13'	$V1+(V0-V1)x$ 950 / 8050
0EH	0	0	1	1	1	0	V14'	$V1+(V0-V1)x$ 600 / 8050
0FH	0	0	1	1	1	1	V15'	$V1+(V0-V1)x$ 300 / 8050
10H	0	1	0	0	0	0	V16'	V1
11H	0	1	0	0	0	1	V17	$V2+(V1-V2)x$ 2450 / 2750
12H	0	1	0	0	1	0	V18'	$V2+(V1-V2)x$ 2200 / 2750
13H	0	1	0	0	1	1	V19'	$V2+(V1-V2)x$ 1950 / 2750
14H	0	1	0	1	0	0	V20'	$V2+(V1-V2)x$ 1700 / 2750
15H	0	1	0	1	0	1	V21'	$V2+(V1-V2)x$ 1500 / 2750
16H	0	1	0	1	1	0	V22'	$V2+(V1-V2)x$ 1300 / 2750
17H	0	1	0	1	1	1	V23'	$V2+(V1-V2)x$ 1100 / 2750
18H	0	1	1	0	0	0	V24'	$V2+(V1-V2)x$ 950 / 2750
19H	0	1	1	0	0	1	V25'	$V2+(V1-V2)x$ 800 / 2750
1AH	0	1	1	0	1	0	V26'	$V2+(V1-V2)x$ 650 / 2750
1BH	0	1	1	0	1	1	V27'	$V2+(V1-V2)x$ 500 / 2750
1CH	0	1	1	1	0	0	V28'	$V2+(V1-V2)x$ 400 / 2750
1DH	0	1	1	1	0	1	V29'	$V2+(V1-V2)x$ 300 / 2750
1EH	0	1	1	1	1	0	V30'	$V2+(V1-V2)x$ 200 / 2750
1FH	0	1	1	1	1	1	V31'	$V2+(V1-V2)x$ 100 / 2750
20H	1	0	0	0	0	0	V32'	V2
21H	1	0	0	0	0	1	V33'	$V3+(V2-V3)x$ 1500 / 1600
22H	1	0	0	0	1	0	V34'	$V3+(V2-V3)x$ 1400 / 1600
23H	1	0	0	0	1	1	V35'	$V3+(V2-V3)x$ 1300 / 1600
24H	1	0	0	1	0	0	V36'	$V3+(V2-V3)x$ 1200 / 1600
25H	1	0	0	1	0	1	V37'	$V3+(V2-V3)x$ 1100 / 1600
26H	1	0	0	1	1	0	V38'	$V3+(V2-V3)x$ 1000 / 1600
27H	1	0	0	1	1	1	V39'	$V3+(V2-V3)x$ 900 / 1600
28H	1	0	1	0	0	0	V40'	$V3+(V2-V3)x$ 800 / 1600
29H	1	0	1	0	0	1	V41'	$V3+(V2-V3)x$ 700 / 1600
2AH	1	0	1	0	1	0	V42'	$V3+(V2-V3)x$ 600 / 1600
2BH	1	0	1	0	1	1	V43'	$V3+(V2-V3)x$ 500 / 1600
2CH	1	0	1	1	0	0	V44'	$V3+(V2-V3)x$ 400 / 1600
2DH	1	0	1	1	0	1	V45'	$V3+(V2-V3)x$ 300 / 1600
2EH	1	0	1	1	1	0	V46'	$V3+(V2-V3)x$ 200 / 1600
2FH	1	0	1	1	1	1	V47'	$V3+(V2-V3)x$ 100 / 1600
30H	1	1	0	0	0	0	V48'	V3
31H	1	1	0	0	0	1	V49'	$V4+(V3-V4)x$ 3350 / 3450
32H	1	1	0	0	1	0	V50'	$V4+(V3-V4)x$ 3250 / 3450
33H	1	1	0	0	1	1	V51'	$V4+(V3-V4)x$ 3150 / 3450
34H	1	1	0	1	0	0	V52'	$V4+(V3-V4)x$ 3050 / 3450
35H	1	1	0	1	0	1	V53'	$V4+(V3-V4)x$ 2950 / 3450
36H	1	1	0	1	1	0	V54'	$V4+(V3-V4)x$ 2800 / 3450
37H	1	1	0	1	1	1	V55'	$V4+(V3-V4)x$ 2650 / 3450
38H	1	1	1	0	0	0	V56'	$V4+(V3-V4)x$ 2500 / 3450
39H	1	1	1	0	0	1	V57'	$V4+(V3-V4)x$ 2300 / 3450
3AH	1	1	1	0	1	0	V58'	$V4+(V3-V4)x$ 2100 / 3450
3BH	1	1	1	0	1	1	V59'	$V4+(V3-V4)x$ 1850 / 3450
3CH	1	1	1	1	0	0	V60'	$V4+(V3-V4)x$ 1600 / 3450
3DH	1	1	1	1	0	1	V61'	$V4+(V3-V4)x$ 1300 / 3450
3EH	1	1	1	1	1	0	V62'	$V4+(V3-V4)x$ 800 / 3450
3FH	1	1	1	1	1	1	V63'	V4

r	(Ω)
r0	800
r1	750
r2	700
r3	650
r4	600
r5	550
r6	550
r7	500
r8	500
r9	400
r10	400
r11	350
r12	350
r13	350
r14	300
r15	300
r16	300
r17	250
r18	250
r19	250
r20	200
r21	200
r22	200
r23	150
r24	150
r25	150
r26	150
r27	100
r28	100
r29	100
r30	100
r31	100
r32	100
r33	100
r34	100
r35	100
r36	100
r37	100
r38	100
r39	100
r40	100
r41	100
r42	100
r43	100
r44	100
r45	100
r46	100
r47	100
r48	100
r49	100
r50	100
r51	100
r52	100
r53	150
r54	150
r55	150
r56	200
r57	200
r58	250
r59	250
r60	300
r61	500
r62	800
r total	15850

Caution There is no connection between V4 and V5 terminal in the chip.

Figure 5-3. Relationship between Input Data and Output Voltage

$$0.5 V_{DD2} > V_5 > V_6 > V_7 > V_8 > V_9 > V_{SS2} + 0.1 V, POL21/22 = L$$

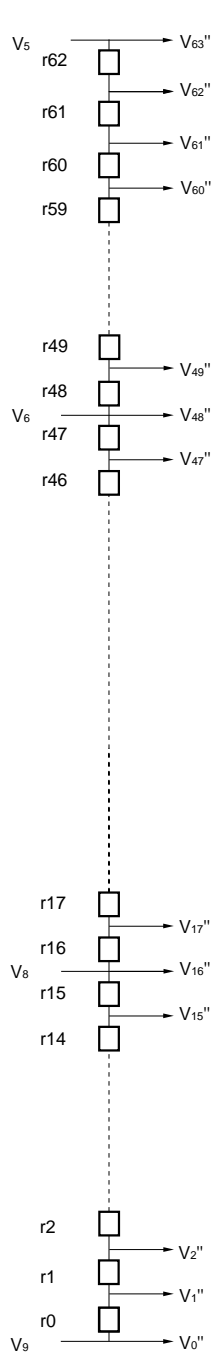

Data	DX5	DX4	DX3	DX2	DX1	DX0	Output voltage	
00H	0	0	0	0	0	0	V0"	V9
01H	0	0	0	0	0	1	V1"	V9+(V8-V9)× 800 / 8050
02H	0	0	0	0	1	0	V2"	V9+(V8-V9)× 1550 / 8050
03H	0	0	0	0	1	1	V3"	V9+(V8-V9)× 2250 / 8050
04H	0	0	0	1	0	0	V4"	V9+(V8-V9)× 2900 / 8050
05H	0	0	0	1	0	1	V5"	V9+(V8-V9)× 3500 / 8050
06H	0	0	0	1	1	0	V6"	V9+(V8-V9)× 4050 / 8050
07H	0	0	0	1	1	1	V7"	V9+(V8-V9)× 4600 / 8050
08H	0	0	1	0	0	0	V8"	V9+(V8-V9)× 5100 / 8050
09H	0	0	1	0	0	1	V9"	V9+(V8-V9)× 5600 / 8050
0AH	0	0	1	0	1	0	V10"	V9+(V8-V9)× 6000 / 8050
0BH	0	0	1	0	1	1	V11"	V9+(V8-V9)× 6400 / 8050
0CH	0	0	1	1	0	0	V12"	V9+(V8-V9)× 6750 / 8050
0DH	0	0	1	1	0	1	V13"	V9+(V8-V9)× 7100 / 8050
0EH	0	0	1	1	1	0	V14"	V9+(V8-V9)× 7450 / 8050
0FH	0	0	1	1	1	1	V15"	V9+(V8-V9)× 7750 / 8050
10H	0	1	0	0	0	0	V16"	V8
11H	0	1	0	0	0	1	V17"	V8+(V7-V8)× 300 / 2750
12H	0	1	0	0	1	0	V18"	V8+(V7-V8)× 550 / 2750
13H	0	1	0	0	1	1	V19"	V8+(V7-V8)× 800 / 2750
14H	0	1	0	1	0	0	V20"	V8+(V7-V8)× 1050 / 2750
15H	0	1	0	1	0	1	V21"	V8+(V7-V8)× 1250 / 2750
16H	0	1	0	1	1	0	V22"	V8+(V7-V8)× 1450 / 2750
17H	0	1	0	1	1	1	V23"	V8+(V7-V8)× 1650 / 2750
18H	0	1	1	0	0	0	V24"	V8+(V7-V8)× 1800 / 2750
19H	0	1	1	0	0	1	V25"	V8+(V7-V8)× 1950 / 2750
1AH	0	1	1	0	1	0	V26"	V8+(V7-V8)× 2100 / 2750
1BH	0	1	1	0	1	1	V27"	V8+(V7-V8)× 2250 / 2750
1CH	0	1	1	1	0	0	V28"	V8+(V7-V8)× 2350 / 2750
1DH	0	1	1	1	0	1	V29"	V8+(V7-V8)× 2450 / 2750
1EH	0	1	1	1	1	0	V30"	V8+(V7-V8)× 2550 / 2750
1FH	0	1	1	1	1	1	V31"	V8+(V7-V8)× 2650 / 2750
20H	1	0	0	0	0	0	V32"	V7
21H	1	0	0	0	0	1	V33"	V7+(V6-V7)× 100 / 1600
22H	1	0	0	0	1	0	V34"	V7+(V6-V7)× 200 / 1600
23H	1	0	0	0	1	1	V35"	V7+(V6-V7)× 300 / 1600
24H	1	0	0	1	0	0	V36"	V7+(V6-V7)× 400 / 1600
25H	1	0	0	1	0	1	V37"	V7+(V6-V7)× 500 / 1600
26H	1	0	0	1	1	0	V38"	V7+(V6-V7)× 600 / 1600
27H	1	0	0	1	1	1	V39"	V7+(V6-V7)× 700 / 1600
28H	1	0	1	0	0	0	V40"	V7+(V6-V7)× 800 / 1600
29H	1	0	1	0	0	1	V41"	V7+(V6-V7)× 900 / 1600
2AH	1	0	1	0	1	0	V42"	V7+(V6-V7)× 1000 / 1600
2BH	1	0	1	0	1	1	V43"	V7+(V6-V7)× 1100 / 1600
2CH	1	0	1	1	0	0	V44"	V7+(V6-V7)× 1200 / 1600
2DH	1	0	1	1	0	1	V45"	V7+(V6-V7)× 1300 / 1600
2EH	1	0	1	1	1	0	V46"	V7+(V6-V7)× 1400 / 1600
2FH	1	0	1	1	1	1	V47"	V7+(V6-V7)× 1500 / 1600
30H	1	1	0	0	0	0	V48"	V6
31H	1	1	0	0	0	1	V49"	V6+(V5-V6)× 100 / 3450
32H	1	1	0	0	1	0	V50"	V6+(V5-V6)× 200 / 3450
33H	1	1	0	0	1	1	V51"	V6+(V5-V6)× 300 / 3450
34H	1	1	0	1	0	0	V52"	V6+(V5-V6)× 400 / 3450
35H	1	1	0	1	0	1	V53"	V6+(V5-V6)× 500 / 3450
36H	1	1	0	1	1	0	V54"	V6+(V5-V6)× 650 / 3450
37H	1	1	0	1	1	1	V55"	V6+(V5-V6)× 800 / 3450
38H	1	1	1	0	0	0	V56"	V6+(V5-V6)× 950 / 3450
39H	1	1	1	0	0	1	V57"	V6+(V5-V6)× 1150 / 3450
3AH	1	1	1	0	1	0	V58"	V6+(V5-V6)× 1350 / 3450
3BH	1	1	1	0	1	1	V59"	V6+(V5-V6)× 1600 / 3450
3CH	1	1	1	1	0	0	V60"	V6+(V5-V6)× 1850 / 3450
3DH	1	1	1	1	0	1	V61"	V6+(V5-V6)× 2150 / 3450
3EH	1	1	1	1	1	0	V62"	V6+(V5-V6)× 2650 / 3450
3FH	1	1	1	1	1	1	V63"	V5

m	(Ω)
r0	800
r1	750
r2	700
r3	650
r4	600
r5	550
r6	550
r7	500
r8	500
r9	400
r10	400
r11	350
r12	350
r13	350
r14	300
r15	300
r16	300
r17	250
r18	250
r19	250
r20	200
r21	200
r22	200
r23	150
r24	150
r25	150
r26	150
r27	100
r28	100
r29	100
r30	100
r31	100
r32	100
r33	100
r34	100
r35	100
r36	100
r37	100
r38	100
r39	100
r40	100
r41	100
r42	100
r43	100
r44	100
r45	100
r46	100
r47	100
r48	100
r49	100
r50	100
r51	100
r52	100
r53	150
r54	150
r55	150
r56	200
r57	200
r58	250
r59	250
r60	300
r61	500
r62	800
total	15850

Caution There is no connection between V4 and V5 terminal in the chip.

6. RELATIONSHIP BETWEEN INPUT DATA AND OUTPUT PIN

Data format : 6 bits x 2 RGBs (6 dots)

Input width : 36 bits (2-pixel data)

(1) R,/L = H (Right shift)

Output	S ₁	S ₂	S ₃	S ₄	...	S ₄₇₉	S ₄₈₀
Data	D ₀₀ to D ₀₅	D ₁₀ to D ₁₅	D ₂₀ to D ₂₅	D ₃₀ to D ₃₅	...	D ₄₀ to D ₄₅	D ₅₀ to D ₅₅

(2) R,/L = L (Left shift)

Output	S ₁	S ₂	S ₃	S ₄	...	S ₄₇₉	S ₄₈₀
Data	D ₀₀ to D ₀₅	D ₁₀ to D ₁₅	D ₂₀ to D ₂₅	D ₃₀ to D ₃₅	...	D ₄₀ to D ₄₅	D ₅₀ to D ₅₅

POL	S _{2n-1} Note	S _{2n} Note
L	V ₀ to V ₄	V ₅ to V ₉
H	V ₅ to V ₉	V ₀ to V ₄

Note S_{2n-1} (Odd output), S_{2n} (Even output)

7. RELATIONSHIP BETWEEN STB, POL AND OUTPUT WAVEFORM

The output voltage is written to the LCD panel synchronized with the STB falling edge.

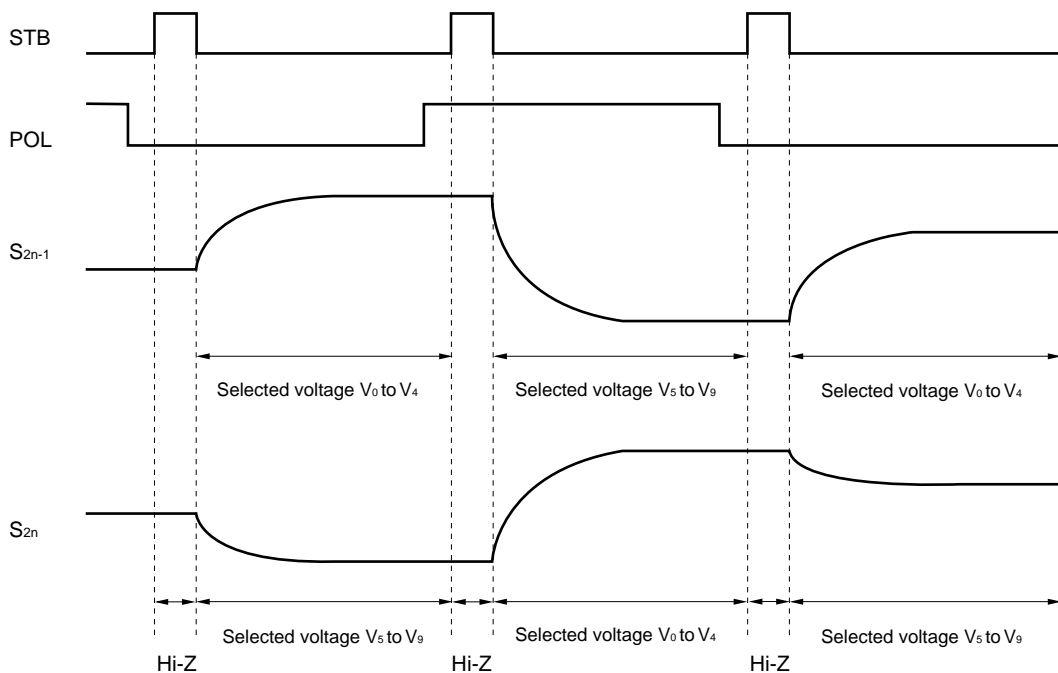

8. RELATIONSHIP BETWEEN STB, CLK AND OUTPUT WAVEFORM

The output voltage is written to the LCD panel synchronized with the STB falling edge.

Figure 8-1. Output Circuit Block Diagram

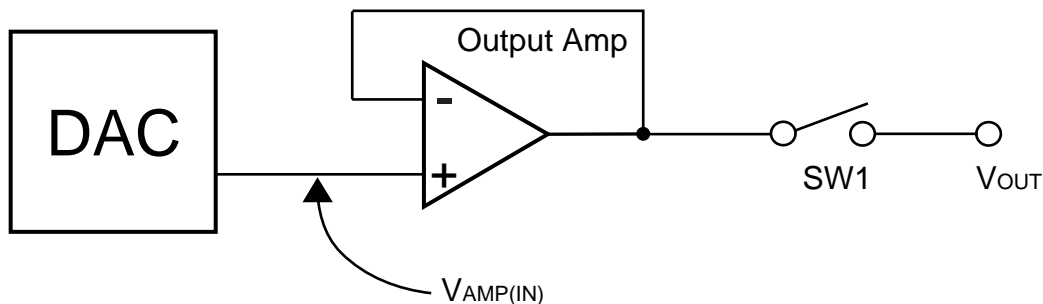
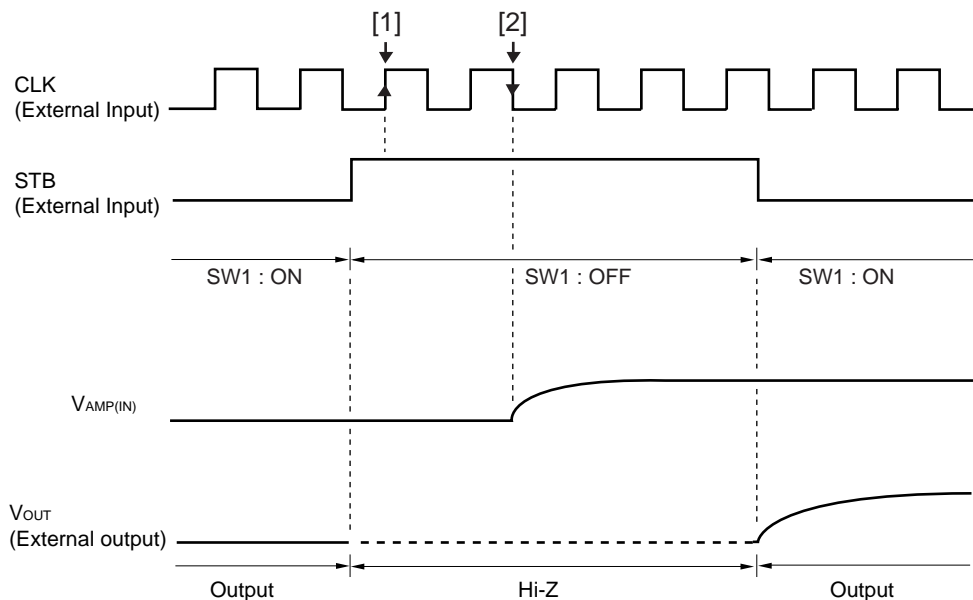

Figure 8-2. Output Circuit Timing Waveform



- Remarks 1.** STB = L : SW1 = ON
 STB = H : SW1 = OFF
2. STB = "H" is acknowledged at timing [1].
 3. The display data latch is compensated at timing [2] and the input voltage ($V_{AMP(IN)}$: gray-scale level voltage) of the output amplifier changes.

9. CURRENT CONSUMPTION REDUCTION FUNCTION

The μPD16772 has a low power control function (LPC) which can switch the bias current of the output amplifier between two levels and a bias control function (Bcont) which can be used to finely control the bias current.

• Low Power Control Function (LPC)

The bias current of the output amplifier can be switched between two levels using this pin (Bcont: Open).

LPC = H or Open: Low power mode

LPC = L: Normal power mode

The V_{DD2} of static current consumption can be reduced to two thirds of that in normal mode. Input a stable DC current (V_{DD1}/V_{SS1}) to this pin.

• Bias Current Control Function (Bcont)

It is possible to fine-control the current consumption by using the bias current control function (Bcont pin). When using this function, connect this pin to the stabilized ground potential (V_{SS2}) via an external resistor (R_{EXT}). When not using this function, leave this pin open.

Figure 9–1. Bias Current Control Function (Bcont)

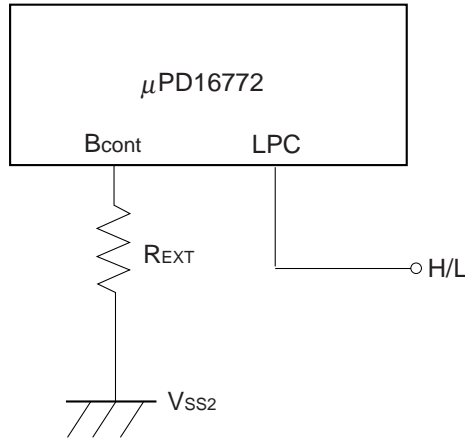

Refer to the table below for the percentage of current regulation when using the bias current control function.

Table 9–1. Current Consumption Regulation Percentage Compared to Normal Mode

R_{EXT}	Current Consumption Regulation Percentage		
	LPC = L	LPC = H/Open	
∞ (Open)	100%	65%	$V_{DD1} = 3.3\text{ V}$
50 kΩ	120%	80%	$V_{DD2} = 8.7\text{ V}$
20 kΩ	140%	100%	
0 Ω	240%	210%	

Remark The above current consumption regulation percentages are not product-characteristic guaranteed as they are based on the results of simulation.

Caution Because the low-power and bias-current control functions control the bias current in the output amplifier and regulate the over-all current consumption of the driver IC, when this occurs, the characteristics of the output amplifier will simultaneously change. Therefore, when using these functions, be sure to sufficiently evaluate the picture quality.

10. ELECTRICAL SPECIFICATIONS

Absolute Maximum Ratings (T_A = 25°C, V_{SS1} = V_{SS2} = 0 V)

Parameter	Symbol	Rating	Unit
Logic Part Supply Voltage	V _{DD1}	-0.5 to +4.0	V
Driver Part Supply Voltage	V _{DD2}	-0.5 to +10.0	V
Logic Part Input Voltage	V _{I1}	-0.5 to V _{DD1} + 0.5	V
Driver Part Input Voltage	V _{I2}	-0.5 to V _{DD2} + 0.5	V
Logic Part Output Voltage	V _{O1}	-0.5 to V _{DD1} + 0.5	V
Driver Part Output Voltage	V _{O2}	-0.5 to V _{DD2} + 0.5	V
Operating Ambient Temperature	T _A	-10 to +75	°C
Storage Temperature	T _{stg}	-55 to +125	°C

- ★ **Caution** Product quality may suffer if the absolute maximum rating is exceeded even momentarily for any parameter. That is, the absolute maximum ratings are rated values at which the product is on the verge of suffering physical damage, and therefore the product must be used under conditions that ensure that the absolute maximum ratings are not exceeded.

Recommended Operating Range (T_A = -10 to +75°C, V_{SS1} = V_{SS2} = 0 V)

Parameter	Symbol	Condition	MIN.	TYP.	MAX.	Unit
Logic Part Supply Voltage	V _{DD1}		2.3		3.6	V
Driver Part Supply Voltage	V _{DD2}		8.0	8.5	9.0	V
High-Level Input Voltage	V _{IH}		0.7 V _{DD1}		V _{DD1}	V
Low-Level Input Voltage	V _{IL}		0		0.3 V _{DD1}	V
γ-Corrected Voltage	V ₀ to V ₉		V _{SS2} + 0.1		V _{DD2} - 0.1	V
Driver Part Output Voltage	V _O		V _{SS2} + 0.1		V _{DD2} - 0.1	V
Clock Frequency	f _{CLK}	V _{DD2} = 2.3 V			45	MHz

Electrical Characteristics ($T_A = -10$ to $+75^\circ\text{C}$, $V_{DD1} = 2.3$ to 3.6 V, $V_{DD2} = 8.5$ V \pm 0.5 V, $V_{SS1} = V_{SS2} = 0$ V, unless otherwise specified, the input level is defined to be LPC = L, Bcont = Open)

Parameter	Symbol	Condition	MIN.	TYP.	MAX.	Unit	
Input Leak Current	I_{IL}				± 1.0	μA	
High-Level Output Voltage	V_{OH}	STHR (STHL), $I_{OH} = 0$ mA	$V_{DD1} - 0.1$			V	
Low-Level Output Voltage	V_{OL}	STHR (STHL), $I_{OL} = 0$ mA			0.1	V	
γ -Corrected Supply Current	I_γ	$V_{DD2} = 8.5$ V	V_0 pin, V_5 pin	126	252	504	μA
		V_0 to $V_4 = V_5$ to $V_9 = 4.0$ V	V_4 pin, V_9 pin	-504	-252	-126	μA
Driver Output Current	I_{VOH}	$V_X = 7.0$ V, $V_{OUT} = 6.5$ V ^{Note}			-30	μA	
	I_{VOL}	$V_X = 1.0$ V, $V_{OUT} = 1.5$ V ^{Note}	30			μA	
Output Voltage Deviation	ΔV_O	$T_A = 25^\circ\text{C}$		± 7	± 20	mV	
Output Swing Difference Deviation	ΔV_{P-P}	$V_{DD1} = 3.3$ V, $V_{DD2} = 8.5$ V $V_{OUT} = 2.0$ V, 4.25 V, 6.5 V		± 2	± 15	mV	
★ Logic Part Dynamic Current Consumption	I_{DD1}	V_{DD1}		1.0	7.5	mA	
★ Driver Part Dynamic Current Consumption	I_{DD2}	V_{DD2} , with no load		3.5	7.5	mA	

Note V_X refers to the output voltage of analog output pins S_1 to S_{480} .
 V_{OUT} refers to the voltage applied to analog output pins S_1 to S_{480} .

- ★ **Cautions** 1. $f_{STB} = 50$ kHz, $f_{CLK} = 40$ MHz
- 2. The TYP. values refer to an all black or all white input pattern. The MAX. value refers to the measured values in the dot checkerboard input pattern.
- 3. Refers to the current consumption per driver when cascades are connected under the assumption of UXGA single-sided mounting (10 units).

Switching Characteristics ($T_A = -10$ to $+75^\circ\text{C}$, $V_{DD1} = 2.3$ to 3.6 V, $V_{DD2} = 8.5$ V \pm 0.5 V, $V_{SS1} = V_{SS2} = 0$ V, unless otherwise specified, the input level is defined to be LPC = L, Bcont = Open)

Parameter	Symbol	Condition	MIN.	TYP.	MAX.	Unit
Start Pulse Delay Time	t_{PLH1}	$C_L = 10$ pF		10	20	ns
	t_{PHL1}			10	20	ns
★ Driver Output Delay Time	t_{PLH2}	$C_L = 75$ pF, $R_L = 5k\Omega$		2.5	5	μs
	t_{PLH3}			5	8	μs
	t_{PHL2}			2.5	5	μs
	t_{PHL3}			5	8	μs
Input Capacitance	C_{I1}	STHR (STHL) excluded, $T_A = 25^\circ\text{C}$		5	10	pF
	C_{I2}	STHR (STHL), $T_A = 25^\circ\text{C}$		8	10	pF

★ Timing Requirements ($T_A = -10$ to $+75^\circ\text{C}$, $V_{DD1} = 2.3$ to 3.6 V, $V_{SS1} = 0$ V, $t_r = t_f = 5.0$ ns)

Parameter	Symbol	Condition	MIN.	TYP.	MAX.	Unit
Clock Pulse Width	PW_{CLK}	$V_{DD1} = 2.3$ to 3.6 V	22			ns
Clock Pulse High Period	$PW_{CLK(H)}$		4			ns
Clock Pulse Low Period	$PW_{CLK(L)}$	$V_{DD1} = 2.3$ to 3.0 V	7			ns
		$V_{DD1} = 3.0$ to 3.6 V	4			ns
Data Setup Time	t_{SETUP1}		3			ns
Data Hold Time	t_{HOLD1}		0			ns
Start Pulse Setup Time	t_{SETUP2}		3			ns
Start Pulse Hold Time	t_{HOLD2}		0			ns
POL21/22 Setup Time	t_{SETUP3}		3			ns
POL21/22 Hold Time	t_{HOLD3}	$V_{DD1} = 2.3$ to 3.0 V	1			ns
		$V_{DD1} = 3.0$ to 3.6 V	0			ns
Start Pulse Low Period	t_{SPL}		1			CLK
STB Pulse Width	PW_{STB}		2			CLK
Last Data Timing	t_{LDT}		2			CLK
CLK-STB Time	$t_{CLK-STB}$	$CLK \uparrow \rightarrow STB \uparrow$	6			ns
STB-CLK Time	$t_{STB-CLK}$	$STB \uparrow \rightarrow CLK \uparrow$ $V_{DD1} = 2.3$ to 3.0 V	14			ns
		$STB \uparrow \rightarrow CLK \uparrow$ $V_{DD1} = 3.0$ to 3.6 V	6			ns
Time Between STB and Start Pulse	$t_{STB-STH}$	$STB \uparrow \rightarrow STHR(STHL) \uparrow$	2			CLK
POL-STB Time	$t_{POL-STB}$	$POL \uparrow$ or $\downarrow \rightarrow STB \uparrow$	-5			ns
STB-POL Time	$t_{STB-POL}$	$STB \downarrow \rightarrow POL \downarrow$ or \uparrow	6			ns

Remark Unless otherwise specified, the input level is defined to be $V_{IH} = 0.7 V_{DD1}$, $V_{IL} = 0.3 V_{DD1}$.

11. SWITCHING CHARACTERISTIC WAVEFORM(R,/L=H)

Unless otherwise specified, the input level is defined to be $V_{IH} = 0.7 V_{DD1}$, $V_{IL} = 0.3 V_{DD1}$.

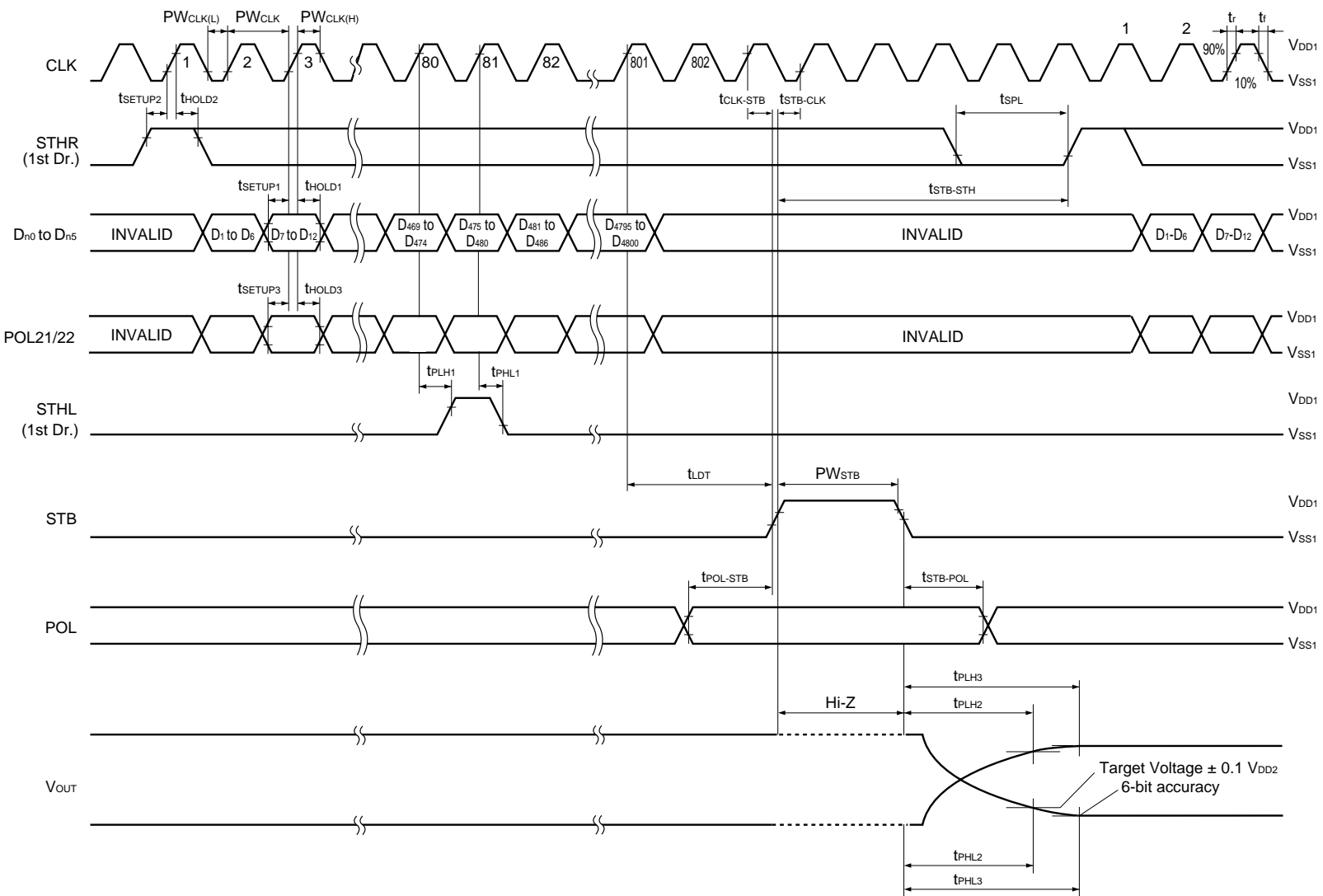

12. RECOMMENDED MOUNTING CONDITIONS

The following conditions must be met for mounting conditions of the μPD16772.

For more details, refer to the **Semiconductor Device Mounting Technology Manual (C10535E)**.

Please consult with our sales offices in case other mounting process is used, or in case the mounting is done under different conditions.

μPD16772N-xxx : TCP (TAB Package)

Mounting Condition	Mounting Method	Condition
Thermocompression	Soldering	Heating tool 300 to 350°C, heating for 2 to 3 seconds : pressure 100g (per solder)
	ACF (Adhesive Conductive Film)	Temporary bonding 70 to 100°C : pressure 3 to 8 kg/cm ² : time 3 to 5 sec. Real bonding 165 to 180°C: pressure 25 to 45 kg/cm ² : time 30 to 40 sec. (When using the anisotropy conductive film SUMIZAC1003 of Sumitomo Bakelite,Ltd).

Caution To find out the detailed conditions for mounting the ACF part, please contact the ACF manufacturing company. Be sure to avoid using two or more mounting methods at a time.

[MEMO]

[MEMO]

NOTES FOR CMOS DEVICES**① PRECAUTION AGAINST ESD FOR SEMICONDUCTORS**

Note:

Strong electric field, when exposed to a MOS device, can cause destruction of the gate oxide and ultimately degrade the device operation. Steps must be taken to stop generation of static electricity as much as possible, and quickly dissipate it once, when it has occurred. Environmental control must be adequate. When it is dry, humidifier should be used. It is recommended to avoid using insulators that easily build static electricity. Semiconductor devices must be stored and transported in an anti-static container, static shielding bag or conductive material. All test and measurement tools including work bench and floor should be grounded. The operator should be grounded using wrist strap. Semiconductor devices must not be touched with bare hands. Similar precautions need to be taken for PW boards with semiconductor devices on it.

② HANDLING OF UNUSED INPUT PINS FOR CMOS

Note:

No connection for CMOS device inputs can be cause of malfunction. If no connection is provided to the input pins, it is possible that an internal input level may be generated due to noise, etc., hence causing malfunction. CMOS devices behave differently than Bipolar or NMOS devices. Input levels of CMOS devices must be fixed high or low by using a pull-up or pull-down circuitry. Each unused pin should be connected to V_{DD} or GND with a resistor, if it is considered to have a possibility of being an output pin. All handling related to the unused pins must be judged device by device and related specifications governing the devices.

③ STATUS BEFORE INITIALIZATION OF MOS DEVICES

Note:

Power-on does not necessarily define initial status of MOS device. Production process of MOS does not define the initial operation status of the device. Immediately after the power source is turned ON, the devices with reset function have not yet been initialized. Hence, power-on does not guarantee out-pin levels, I/O settings or contents of registers. Device is not initialized until the reset signal is received. Reset operation must be executed immediately after power-on for devices having reset function.