

Single Cell Lithium-Ion Charge Management Controller with Charge Complete Indicator and Temperature Monitor

Features

- Linear Charge Management Controller for Single Lithium-Ion Cells
- High Accuracy Preset Voltage Regulation: $\pm 1\%$ (max)
- Two Preset Voltage Regulation Options:
 - 4.1V - MCP73828-4.1
 - 4.2V - MCP73828-4.2
- Programmable Charge Current
- Automatic Cell Preconditioning of Deeply Depleted Cells, Minimizing Heat Dissipation During Initial Charge Cycle
- Charge Complete Output CD10 for LED or Microcontroller Interface
- Continuous Temperature Monitoring
- Automatic Power-Down when Input Power Removed
- Temperature Range: -20°C to $+85^{\circ}\text{C}$
- Packaging: 8-Pin MSOP

Applications

- Single Cell Lithium-Ion Battery Chargers
- Personal Data Assistants
- Cellular Telephones
- Hand Held Instruments
- Cradle Chargers
- Digital Cameras

Typical Application Circuit

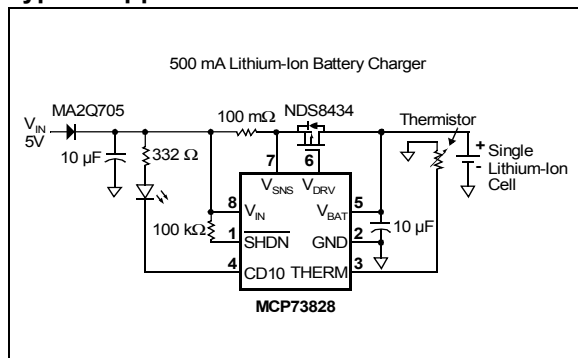

Description

The MCP73828 is a linear charge management controller for use in space-limited, cost sensitive applications. The MCP73828 combines high accuracy constant voltage, controlled current regulation, cell preconditioning, cell temperature monitoring, and charge complete indication in a space saving 8-pin MSOP package. The MCP73828 provides a stand-alone charge management solution.

The MCP73828 charges the battery in three phases: preconditioning, controlled current, and constant voltage. If the battery voltage is below the internal low-voltage threshold, the battery is preconditioned with a foldback current. The preconditioning phase protects the lithium-ion cell and minimizes heat dissipation.

Following the preconditioning phase, the MCP73828 enters the controlled current phase. The MCP73828 allows for design flexibility with a programmable charge current set by an external sense resistor. The charge current is ramped up, based on the cell voltage, from the foldback current to the peak charge current established by the sense resistor. This phase is maintained until the battery reaches the charge-regulation voltage.

Then, the MCP73828 enters the final phase, constant voltage. The accuracy of the voltage regulation is better than $\pm 1\%$ over the entire operating temperature range and supply voltage range. The MCP73828-4.1 is preset to a regulation voltage of 4.1V, while the MCP73828-4.2 is preset to 4.2V. The charge complete output, CD10, indicates when the charge current has diminished to approximately 10% of the peak charge current established by the sense resistor.

The MCP73828 operates with an input voltage range from 4.5V to 5.5V. The MCP73828 is fully specified over the ambient temperature range of -20°C to $+85^{\circ}\text{C}$.

Package Type

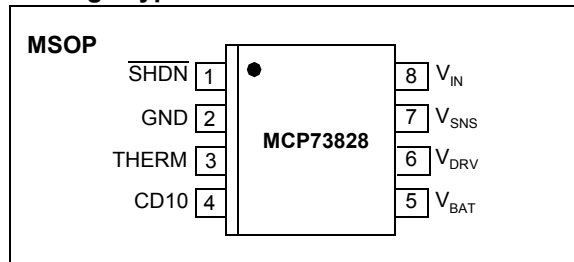

MCP73828

Functional Block Diagram

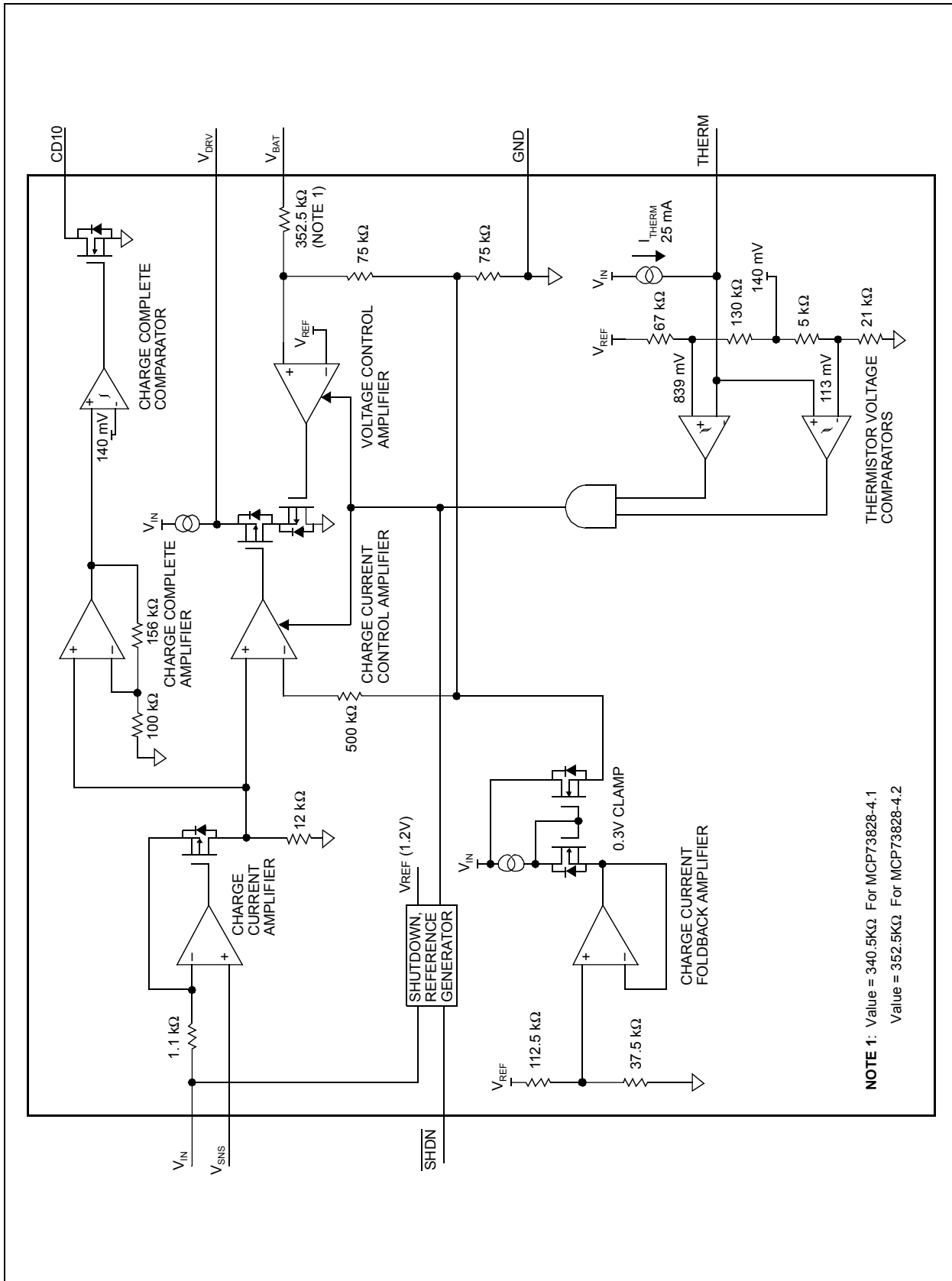

1.0 ELECTRICAL CHARACTERISTICS

1.1 Maximum Ratings*

V_{IN}-0.3V to 6.0V
 All inputs and outputs w.r.t. GND-0.3 to ($V_{IN}+0.3$)V
 Current at CD10 Pin +/-30 mA
 Current at V_{DRV} +/-1 mA
 Maximum Junction Temperature, T_J 150°C
 Storage temperature-65°C to +150°C
 ESD protection on all pins..... ≥ 4 kV

***Notice:** Stresses above those listed under “Maximum Ratings” may cause permanent damage to the device. This is a stress rating only and functional operation of the device at those or any other conditions above those indicated in the operational listings of this specification is not implied. Exposure to maximum rating conditions for extended periods may affect device reliability.

PIN FUNCTION TABLE

Pin	Name	Description
1	\overline{SHDN}	Logic Shutdown
2	GND	Battery Management 0V Reference
3	THERM	Cell Temperature Monitor
4	CD10	Charge Complete Output
5	V_{BAT}	Cell Voltage Monitor Input
6	V_{DRV}	Drive Output
7	V_{SNS}	Charge Current Sense Input
8	V_{IN}	Battery Management Input Supply

DC CHARACTERISTICS: MCP73828-4.1, MCP73828-4.2

Unless otherwise specified, all limits apply for $V_{IN} = [V_{REG}(typ)+1V]$, $R_{SENSE} = 500$ m Ω , $T_A = -20^\circ\text{C}$ to $+85^\circ\text{C}$.
 Typical values are at $+25^\circ\text{C}$. Refer to Figure 1-1 for test circuit.

Parameter	Sym	Min	Typ	Max	Units	Conditions
Supply Voltage	V_{IN}	4.5	—	5.5	V	
Supply Current	I_{IN}	—	0.7 265	15 560	μA	Shutdown, $V_{SHDN} = 0\text{V}$ Constant Voltage Mode
Voltage Regulation (Constant Voltage Mode)						
Regulated Output Voltage	V_{REG}	4.059 4.158	4.1 4.2	4.141 4.242	V	MCP73828-4.1 only MCP73828-4.2 only
Line Regulation	ΔV_{BAT}	-10	—	10	mV	$V_{IN} = 4.5\text{V}$ to 5.5V , $I_{OUT} = 75$ mA
Load Regulation	ΔV_{BAT}	-1	± 0.2	+1	mV	$I_{OUT} = 10$ mA to 75 mA
Output Reverse Leakage Current	I_{LK}	—	10	—	μA	$V_{IN} = \text{Floating}$, $V_{BAT} = V_{REG}$
External MOSFET Gate Drive						
Gate Drive Current	I_{DRV}	— 0.08	— —	1 —	mA mA	Sink, CV Mode Source, CV Mode
Gate Drive Minimum Voltage	V_{DRV}	—	1.6	—	V	
Current Regulation (Controlled Current Mode)						
Current Sense Gain	A_{CS}	—	100	—	dB	$\Delta(V_{SNS}-V_{DRV}) / \Delta V_{BAT}$
Current Limit Threshold	V_{CS}	40	53	75	mV	$(V_{IN}-V_{SNS})$ at I_{OUT}
Foldback Current Scale Factor	K	—	0.43	—	A/A	
Charge Complete Indicator - CD10						
Current Threshold	I_{TH}	—	10	—	% $I_{OUT(PEAK)}$	
Low Output Voltage	V_{OL}	—	—	400	mV	$I_{SINK} = 10$ mA
Leakage Current	I_{LK}	—	—	1	μA	$I_{SINK} = 0$ mA, $V_{CD10} = 5.5\text{V}$
Shutdown Input - SHDN						
Input High Voltage Level	V_{IH}	40	—	—	% V_{IN}	
Input Low Voltage Level	V_{IL}	—	—	25	% V_{IN}	
Input Leakage Current	I_{LK}	—	—	1	μA	$V_{SHDN} = 0\text{V}$ to 5.5V

MCP73828

Unless otherwise specified, all limits apply for $V_{IN} = [V_{REG}(typ)+1V]$, $R_{SENSE} = 500\text{ m}\Omega$, $T_A = -20^\circ\text{C}$ to $+85^\circ\text{C}$. Typical values are at $+25^\circ\text{C}$. Refer to Figure 1-1 for test circuit.

Parameter	Sym	Min	Typ	Max	Units	Conditions
Temperature Monitor - THERM						
Thermistor Bias Current	I_{THERM}	22.5	25.0	27.5	μA	
THERM Threshold Voltages	V_{TH}	—	113	—	mV	Lower Threshold Voltage Upper Threshold Voltage

TEMPERATURE SPECIFICATIONS

Unless otherwise specified, all limits apply for $V_{IN} = 4.5\text{V}-5.5\text{V}$

Parameters	Sym	Min	Typ	Max	Units	Conditions
Temperature Ranges						
Specified Temperature Range	T_A	-20	—	+85	$^\circ\text{C}$	
Operating Temperature Range	T_A	-40	—	+125	$^\circ\text{C}$	
Storage Temperature Range	T_A	-65	—	+150	$^\circ\text{C}$	
Package Thermal Resistance						
Thermal Resistance, 8L-MSOP	θ_{JA}	—	206	—	$^\circ\text{C}/\text{W}$	Single Layer SEMI G42-88 Standard Board, Natural Convection

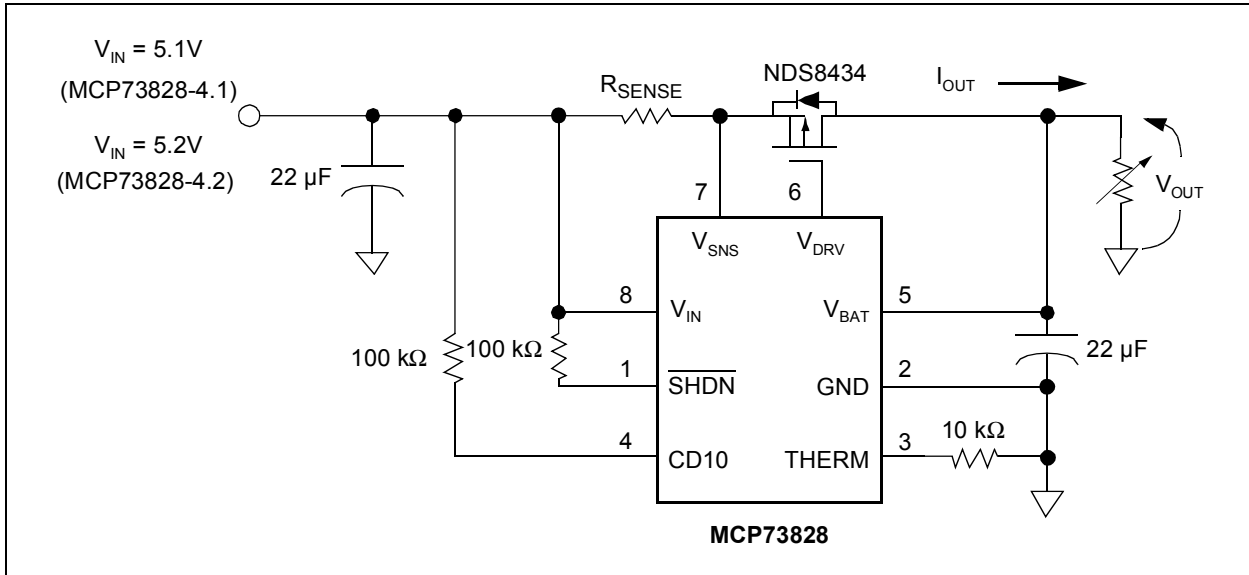

FIGURE 1-1: MCP73828 Test Circuit.

2.0 TYPICAL PERFORMANCE CHARACTERISTICS

Note: The graphs and tables provided following this note are a statistical summary based on a limited number of samples and are provided for informational purposes only. The performance characteristics listed herein are not tested or guaranteed. In some graphs or tables, the data presented may be outside the specified operating range (e.g., outside specified power supply range) and therefore outside the warranted range.

Note: Unless otherwise indicated, $I_{OUT} = 10\text{ mA}$, Constant Voltage Mode, $T_A = 25^\circ\text{C}$. Refer to Figure 1-1 for test circuit.

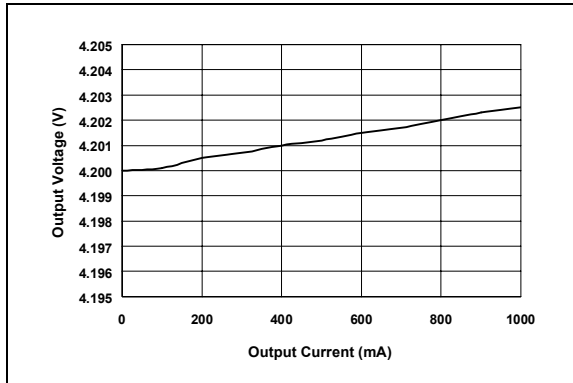

FIGURE 2-1: Output Voltage vs. Output Current (MCP73828-4.2).

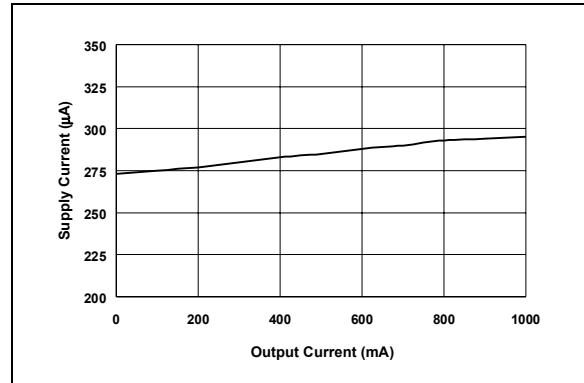

FIGURE 2-4: Supply Current vs. Output Current.

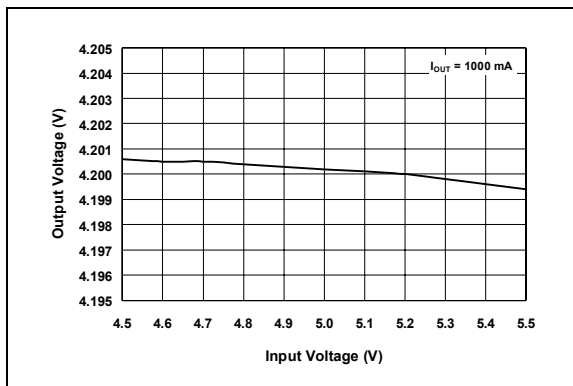

FIGURE 2-2: Output Voltage vs. Input Voltage (MCP73828-4.2).

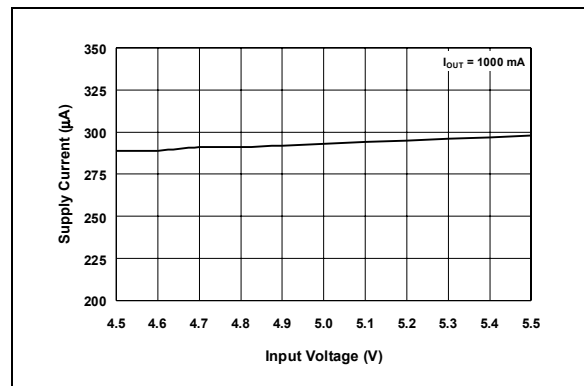

FIGURE 2-5: Supply Current vs. Input Voltage.

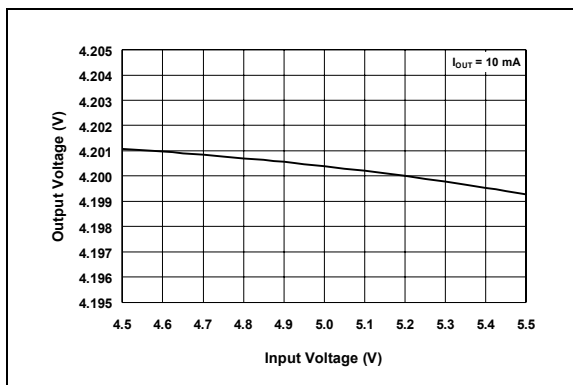

FIGURE 2-3: Output Voltage vs. Input Voltage (MCP73828-4.2).

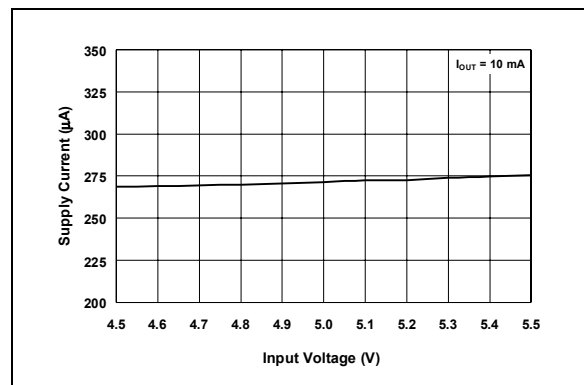

FIGURE 2-6: Supply Current vs. Input Voltage.

MCP73828

Note: Unless otherwise indicated, $I_{OUT} = 10\text{ mA}$, Constant Voltage Mode, $T_A = 25^\circ\text{C}$. Refer to Figure 1-1 for test circuit.

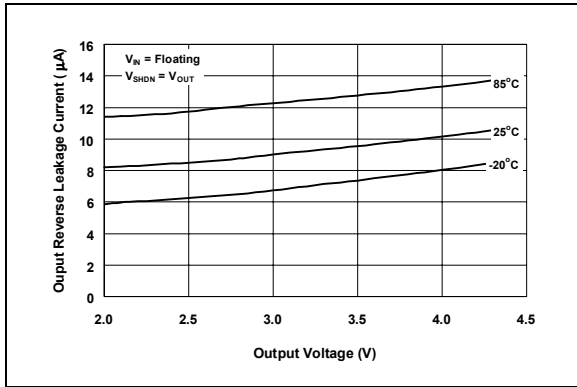

FIGURE 2-7: Output Reverse Leakage Current vs. Output Voltage.

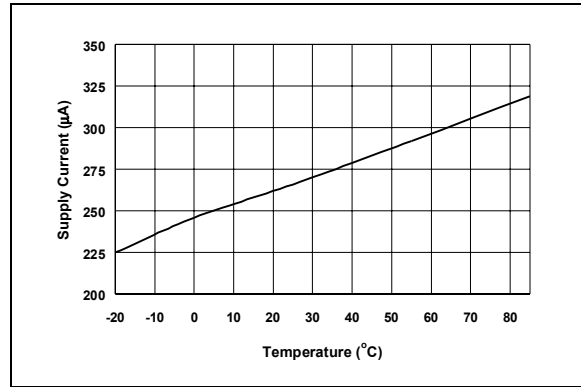

FIGURE 2-10: Supply Current vs. Temperature.

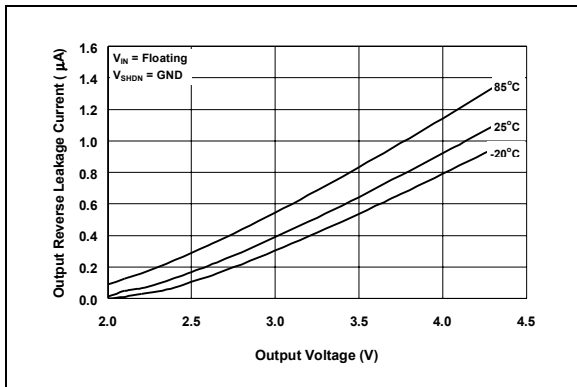

FIGURE 2-8: Output Reverse Leakage Current vs. Output Voltage.

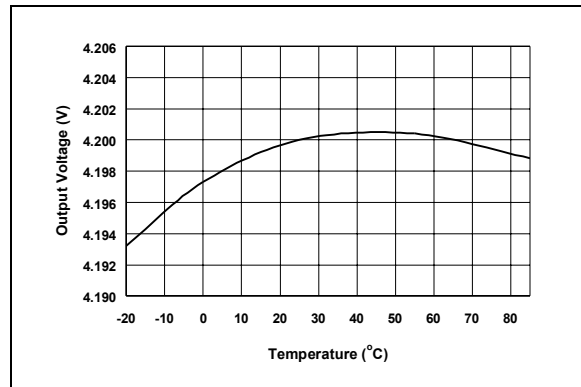

FIGURE 2-11: Output Voltage vs. Temperature (MCP73828-4.2).

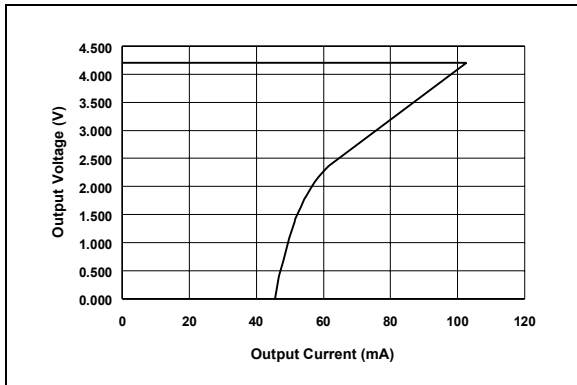

FIGURE 2-9: Current Limit Foldback.

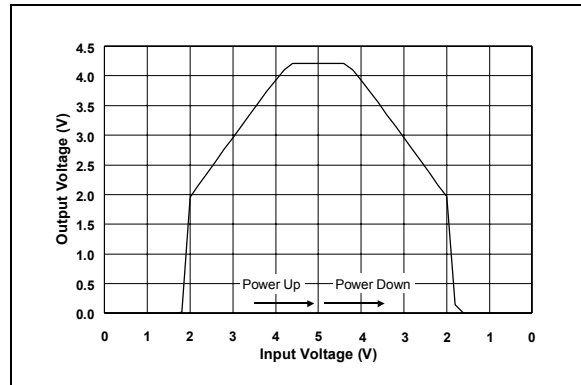

FIGURE 2-12: Power-Up / Power-Down.

Note: Unless otherwise indicated, $I_{OUT} = 10\text{ mA}$, Constant Voltage Mode, $T_A = 25^\circ\text{C}$. Refer to Figure 1-1 for test circuit.

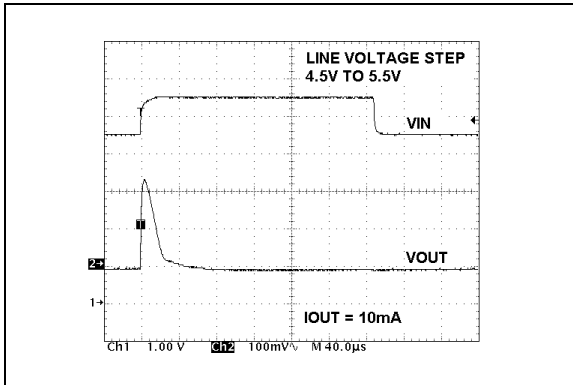

FIGURE 2-13: Line Transient Response.

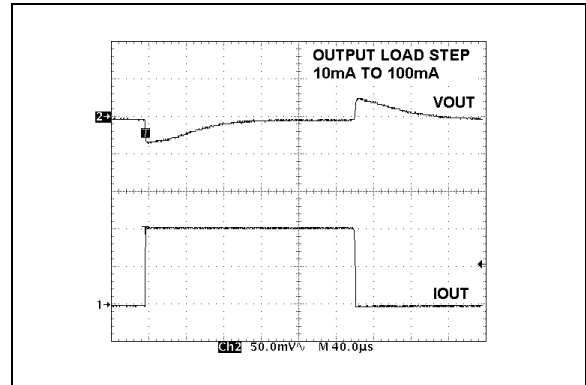

FIGURE 2-15: Load Transient Response.

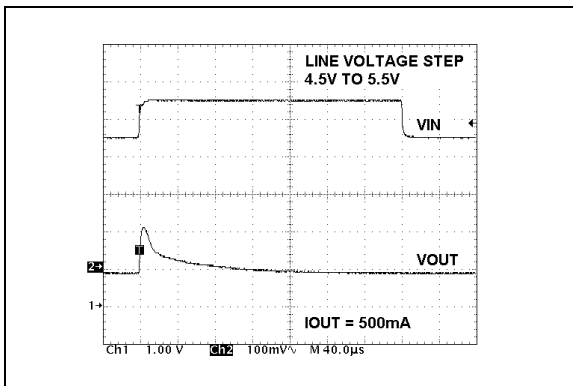

FIGURE 2-14: Line Transient Response.

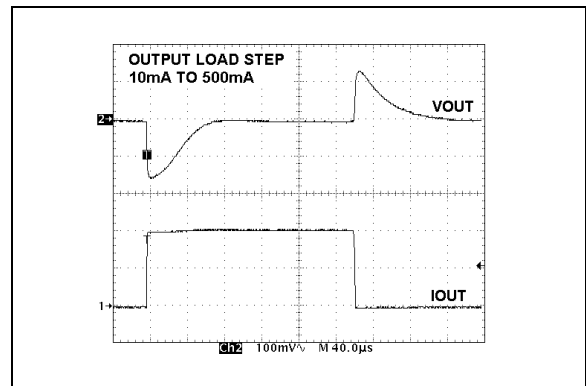

FIGURE 2-16: Load Transient Response.

MCP73828

3.0 PIN DESCRIPTION

The descriptions of the pins are listed in Table 3-1.

Pin	Name	Description
1	$\overline{\text{SHDN}}$	Logic Shutdown
2	GND	Battery Management 0V Reference
3	THERM	Cell Temperature Monitor
4	CD10	Charge Complete Output
5	V _{BAT}	Cell Voltage Monitor Input
6	V _{DRV}	Drive Output
7	V _{SNS}	Charge Current Sense Input
8	V _{IN}	Battery Management Input Supply

TABLE 3-1: Pin Function Table.

3.1 Logic Shutdown ($\overline{\text{SHDN}}$)

Input to force charge termination, initiate charge, or initiate recharge.

3.2 Battery Management 0V Reference (GND)

Connect to negative terminal of battery.

3.3 Cell Temperature Monitor (THERM)

Charging is inhibited when the input is outside the upper and lower threshold limits. Connection of a 10 k Ω resistor between THERM and GND disables the function when cell temperature monitoring is not required.

3.4 Charge Complete Output (CD10)

Open-drain drive for connection to an LED for charge complete indication. Alternatively, a pull-up resistor can be applied for interfacing to a microcontroller. A low impedance state indicates charging. A high impedance indicates that the charge current has diminished below 10% of the peak charge current.

3.5 Cell Voltage Monitor Input (V_{BAT})

Voltage sense input. Connect to positive terminal of battery. Bypass to GND with a minimum of 10 μF to ensure loop stability when the battery is disconnected. A precision internal resistor divider regulates the final voltage on this pin to V_{REG}.

3.6 Drive Output (V_{DRV})

Direct output drive of an external P-channel MOSFET pass transistor for current and voltage regulation.

3.7 Charge Current Sense Input (V_{SNS})

Charge current is sensed via the voltage developed across an external precision sense resistor. The sense resistor must be placed between the supply voltage (V_{IN}) and the source of the external pass transistor. A 50 m Ω sense resistor produces a fast charge current of 1 A, typically.

3.8 Battery Management Input Supply (V_{IN})

A supply voltage of 4.5V to 5.5V is recommended. Bypass to GND with a minimum of 10 μF .

4.0 DEVICE OVERVIEW

The MCP73828 is a linear charge management controller. Refer to the functional block diagram on page 2 and the typical application circuit, Figure 6-1.

4.1 Charge Qualification and Preconditioning

Upon insertion of a battery or application of an external supply, the MCP73828 automatically performs a series of safety checks to qualify the charge. The $\overline{\text{SHDN}}$ pin must be above the logic high level, and the cell temperature monitor must be within the upper and lower threshold limits. The qualification parameters are continuously monitored. Deviation beyond the limits, automatically suspends the charge cycle.

After the qualification parameters have been met, the MCP73828 initiates a charge cycle. The charge complete output, CD10, is pulled low throughout the preconditioning and controlled current phases (see Table 5-1 for charge complete outputs). If the cell voltage is below the preconditioning threshold, 2.4V typically, the MCP73828 preconditions the cell with a scaled back current. The preconditioning current is set to approximately 43% of the fast charge peak current. The preconditioning safely replenishes deeply depleted cells and minimizes heat dissipation in the external pass transistor during the initial charge cycle.

4.2 Controlled Current Regulation - Fast Charge

Preconditioning ends and fast charging begins when the cell voltage exceeds the preconditioning threshold. Fast charge utilizes a foldback current scheme based on the voltage at the V_{SNS} input developed by the drop across an external sense resistor, R_{SENSE} , and the output voltage, V_{BAT} . Fast charge continues until the cell voltage reaches the regulation voltage, V_{REG} .

4.3 Constant Voltage Regulation

When the cell voltage reaches the regulation voltage, V_{REG} , constant voltage regulation begins. The MCP73828 monitors the cell voltage at the V_{OUT} pin. This input is tied directly to the positive terminal of the battery. The MCP73828 is offered in two fixed-voltage versions for battery packs with either coke or graphite anodes: 4.1V (MCP73828-4.1) and 4.2V (MCP73828-4.2).

4.4 Charge Cycle Completion

The charge cycle can be terminated by a host microcontroller when the charge current has diminished below approximately 10% of the peak output voltage level. The charge complete output will go to a high impedance state signaling when the charge can be terminated. The charge is terminated by pulling the shutdown pin, $\overline{\text{SHDN}}$, to a logic Low level.

MCP73828

5.0 DETAILED DESCRIPTION

Refer to the typical application circuit, Figure 6-1.

5.1 Analog Circuitry

5.1.1 CELL TEMPERATURE MONITOR (THERM)

The cell temperature monitor, THERM, input is used to inhibit charging when the battery temperature exceeds a predetermined temperature range. This temperature range is programmed externally with either a single Thermistor or a resistor/Thermistor network. An example of this type of network is illustrated in Figure 6-1.

The MCP73828 internally generates a current source out of the THERM pin (shown in the Functional Block Diagram). The nominal value of the current source (I_{THERM}) is 25 μ A. This current flows through the thermistor network to ground. The factory programmed voltage range of the THERM input (V_{TH}) is 113 mV (typ) to 839 mV (typ). Dependent on the type of Thermistor used and the resistive network, the temperature trip points can be controlled. If the THERM pin is lower than 113 mV or higher than 839 mV the device will shut-down operation. This condition can be corrected by bringing the THERM pin back between these threshold voltages.

As an application example, if a 10 k Ω NTC Thermistor with a sensitivity index (b) of 3982 is connected from THERM to ground, the operational temperature range is from -0.5°C to 44.2°C. See Section 6.1.1.6 for more details concerning using the resistive network.

Alternatively, a positive temperature coefficient, PTC, thermistor can be utilized. Connect the thermistor from the THERM input to GND. If temperature monitoring is not required, replace the thermistor with a standard 10 k Ω resistor.

5.1.2 CELL VOLTAGE MONITOR INPUT (V_{BAT})

The MCP73828 monitors the cell voltage at the V_{BAT} pin. This input is tied directly to the positive terminal of the battery. The MCP73828 is offered in two fixed-voltage versions for single cells with either coke or graphite anodes: 4.1V (MCP73828-4.1) and 4.2V (MCP73828-4.2).

5.1.3 GATE DRIVE OUTPUT (V_{DRV})

The MCP73828 controls the gate drive to an external P-channel MOSFET, Q1. The P-channel MOSFET is controlled in the linear region, regulating current and voltage supplied to the cell. The drive output is automatically turned off when the input supply falls below the voltage sensed on the V_{BAT} input.

5.1.4 CURRENT SENSE INPUT (V_{SNS})

Fast charge current regulation is maintained by the voltage drop developed across an external sense resistor, R_{SENSE} , applied to the V_{SNS} input pin. The following formula calculates the value for R_{SENSE} :

$$R_{SENSE} = \frac{V_{CS}}{I_{OUT}}$$

Where:

V_{CS} is the current limit threshold.

I_{OUT} is the desired peak fast charge current in amps. The preconditioning current is scaled to approximately 43% of I_{OUT} .

5.1.5 SUPPLY VOLTAGE (V_{IN})

The V_{IN} input is the input supply to the MCP73828. The MCP73828 automatically enters a power-down mode if the voltage on the V_{IN} input falls below the voltage on the V_{BAT} pin. This feature prevents draining the battery pack when the V_{IN} supply is not present.

5.2 Digital Circuitry

5.2.1 SHUTDOWN INPUT (\overline{SHDN})

The shutdown input pin, \overline{SHDN} , can be used to terminate a charge anytime during the charge cycle, initiate a charge cycle, or initiate a recharge cycle.

Applying a logic High input signal to the \overline{SHDN} pin, or tying it to the input source, enables the device. Applying a logic Low input signal disables the device and terminates a charge cycle. In shutdown mode, the device's supply current is reduced to 0.7 μ A, typically.

5.2.2 CHARGE COMPLETE OUTPUT (CD10)

A charge complete indicator, CD10, provides information on the state of charge. The open-drain output can be used to illuminate an external LED. Optionally, a pull-up resistor can be used on the output for communication with a microcontroller. Table 5-1 summarizes the state of this output during a charge cycle.

Charge Cycle State	Mode
Qualification	OFF
Preconditioning	ON
Controlled Current Fast Charge	ON
Constant Voltage	ON
Charge Complete	OFF
Temperature Monitor Invalid	OFF
Disabled - Sleep mode	OFF
Battery Disconnected	OFF

TABLE 5-1: Charge Complete Output.

6.0 APPLICATIONS

The MCP73828 is designed to operate in conjunction with a host microcontroller or in stand-alone applications. The MCP73828 provides the preferred charge algorithm for Lithium-Ion cells, controlled current fol-

lowed by constant voltage. Figure 6-1 depicts a typical stand-alone application circuit and Figure 6-2 depicts the accompanying charge profile.

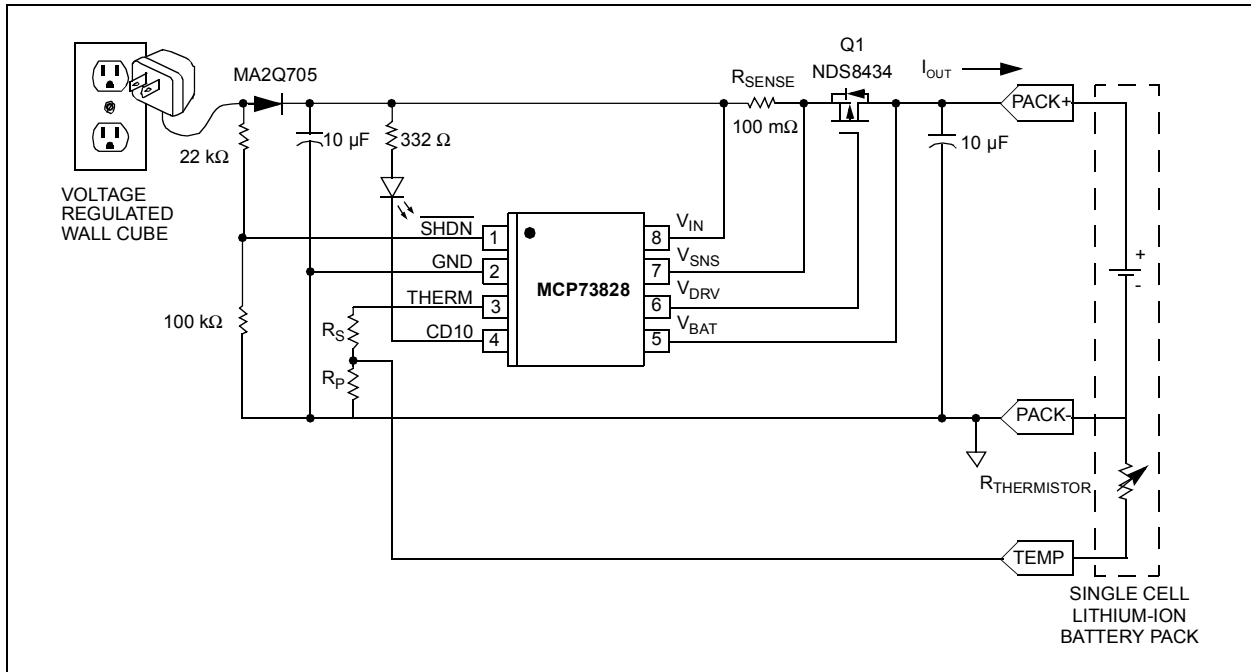

FIGURE 6-1: Typical Application Circuit.

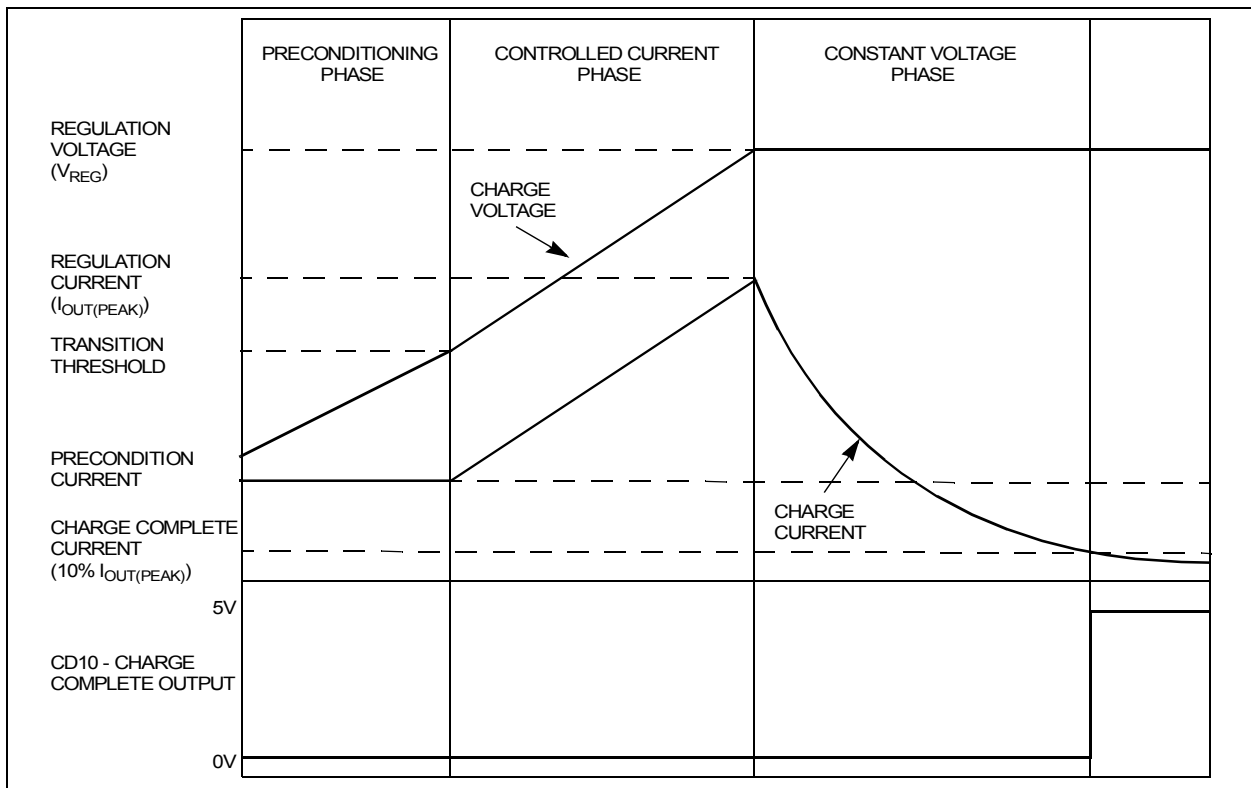

FIGURE 6-2: Typical Charge Profile.

MCP73828

6.1 Application Circuit Design

Due to the low efficiency of linear charging, the most important factors are thermal design and cost, which are a direct function of the input voltage, output current and thermal impedance between the external P-channel pass transistor, Q1, and the ambient cooling air. The worst-case situation is when the output is shorted. In this situation, the P-channel pass transistor has to dissipate the maximum power. A trade-off must be made between the charge current, cost and thermal requirements of the charger.

6.1.1 COMPONENT SELECTION

Selection of the external components in Figure 6-1 is crucial to the integrity and reliability of the charging system. The following discussion is intended as a guide for the component selection process.

6.1.1.1 SENSE RESISTOR

The preferred fast charge current for Lithium-Ion cells is at the 1C rate with an absolute maximum current at the 2C rate. For example, a 500 mAH battery pack has a preferred fast charge current of 500 mA. Charging at this rate provides the shortest charge cycle times without degradation to the battery pack performance or life.

The current sense resistor, R_{SENSE} , is calculated by:

$$R_{SENSE} = \frac{V_{CS}}{I_{OUT}}$$

Where:

V_{CS} is the current limit threshold voltage

I_{OUT} is the desired fast charge current

For the 500 mAH battery pack example, a standard value 100 m Ω , 1% resistor provides a typical peak fast charge current of 530 mA and a maximum peak fast charge current of 758 mA. Worst case power dissipation in the sense resistor is:

$$PowerDissipation = 100m\Omega \times 758mA^2 = 57.5mW$$

A Panasonic ERJ-L1WKF100U 100 m Ω , 1%, 1 W resistor is more than sufficient for this application.

A larger value sense resistor will decrease the peak fast charge current and power dissipation in both the sense resistor and external pass transistor, but will increase charge cycle times. Design trade-offs must be considered to minimize space while maintaining the desired performance.

6.1.1.2 EXTERNAL PASS TRANSISTOR

The external P-channel MOSFET is determined by the gate to source threshold voltage, input voltage, output voltage, and peak fast charge current. The selected P-channel MOSFET must satisfy the thermal and electrical design requirements.

Thermal Considerations

The worst case power dissipation in the external pass transistor occurs when the input voltage is at the maximum and the output is shorted. In this case, the power dissipation is:

$$PowerDissipation = V_{INMAX} \times I_{OUT} \times K$$

Where:

V_{INMAX} is the maximum input voltage

I_{OUT} is the maximum peak fast charge current

K is the foldback current scale factor

Power dissipation with a 5V, +/-10% input voltage source, 100 m Ω , 1% sense resistor, and a scale factor of 0.43 is:

$$PowerDissipation = 5.5V \times 758mA \times 0.43 = 1.8W$$

Utilizing a Fairchild NDS8434 or an International Rectifier IRF7404 mounted on a 1in² pad of 2 oz. copper, the junction temperature rise is 90°C, approximately. This would allow for a maximum operating ambient temperature of 60°C.

By increasing the size of the copper pad, a higher ambient temperature can be realized or a lower value sense resistor could be utilized.

Alternatively, different package options can be utilized for more or less power dissipation. Again, design trade-offs should be considered to minimize size while maintaining the desired performance.

Electrical Considerations

The gate to source threshold voltage and $R_{DS(ON)}$ of the external P-channel MOSFET must be considered in the design phase.

The worst case, V_{GS} provided by the controller occurs when the input voltage is at the minimum and the charge current is at the maximum. The worst case, V_{GS} is:

$$V_{GS} = V_{DRVMAX} - (V_{INMIN} - I_{OUT} \times R_{SENSE})$$

Where:

V_{DRVMAX} is the maximum sink voltage at the V_{DRV} output

V_{INMIN} is the minimum input voltage source

I_{OUT} is the maximum peak fast charge current

R_{SENSE} is the sense resistor

Worst case, V_{GS} with a 5V, +/-10% input voltage source, 100 mΩ, 1% sense resistor, and a maximum sink voltage of 1.6V is:

$$V_{GS} = 1.6V - (4.5V - 758mA \times 99m\Omega) = -2.8V$$

At this worst case V_{GS} , the R_{DSON} of the MOSFET must be low enough as to not impede the performance of the charging system. The maximum allowable R_{DSON} at the worst case V_{GS} is:

$$R_{DSON} = \frac{V_{INMIN} - I_{PEAK} \times R_{SENSE} - V_{BATMAX}}{I_{OUT}}$$

$$R_{DSON} = \frac{4.5V - 758mA \times 99m\Omega - 4.242V}{758mA} = 242m\Omega$$

The Fairchild NDS8434 and International Rectifier IRF7404 both satisfy these requirements.

6.1.1.3 EXTERNAL CAPACITORS

The MCP73828 is stable with or without a battery load. In order to maintain good AC stability in the constant voltage mode, a minimum capacitance of 10 μF is recommended to bypass the V_{BAT} pin to GND. This capacitance provides compensation when there is no battery load. In addition, the battery and interconnections appear inductive at high frequencies. These elements are in the control feedback loop during constant voltage mode. Therefore, the bypass capacitance may be necessary to compensate for the inductive nature of the battery pack.

Virtually any good quality output filter capacitor can be used, independent of the capacitor's minimum ESR (Effective Series Resistance) value. The actual value of the capacitor and its associated ESR depends on the forward trans conductance, g_m , and capacitance of the external pass transistor. A 10 μF tantalum or aluminum electrolytic capacitor at the output is usually sufficient to ensure stability for up to a 1 A output current.

6.1.1.4 REVERSE BLOCKING PROTECTION

The optional reverse blocking protection diode depicted in Figure 6-1 provides protection from a faulted or shorted input or from a reversed polarity input source. Without the protection diode, a faulted or shorted input would discharge the battery pack through the body diode of the external pass transistor.

If a reverse protection diode is incorporated in the design, it should be chosen to handle the peak fast charge current continuously at the maximum ambient temperature. In addition, the reverse leakage current of the diode should be kept as small as possible.

6.1.1.5 SHUTDOWN INTERFACE

In the stand-alone configuration, the shutdown pin is generally tied to the input voltage. The MCP73828 will automatically enter a low power mode when the input voltage is less than the output voltage reducing the battery drain current to 10 μA, typically.

By connecting the shutdown pin as depicted in Figure 6-1, the battery drain current may be further reduced. In this application, the battery drain current becomes a function of the reverse leakage current of the reverse protection diode.

6.1.1.6 CELL TEMPERATURE MONITOR

As discussed in Section 5.1.1, the MCP73828 can monitor a temperature range for -0.5°C to 44.2°C. This temperature range can be expanded or shifted by placing fixed value resistors in series/parallel combinations with the thermistor (see Figure 6-1). Given that the nominal output current of the THERM pin is 25 μA, the resistor values must satisfy the following equations:

$$R_S + \frac{R_P \times R_{THERMISTOR-H}}{R_P + R_{THERMISTOR-H}} = 4520\Omega(typ)$$

$$R_S + \frac{R_P \times R_{THERMISTOR-C}}{R_P + R_{THERMISTOR-C}} = 33560\Omega(typ)$$

Where:

R_S is the fixed series resistance

R_P is the fixed parallel resistance

$R_{THERMISTOR-H}$ is the NTC thermistor resistance at the upper temperature of interest

$R_{THERMISTOR-C}$ is the NTC thermistor resistance at the lower temperature of interest.

For example, by utilizing a 931 Ω resistor in series with the typical NTC thermistor described previously, the monitored temperature window will shift to 0°C to +50°C, typically. Again, with the same thermistor, a 1 kΩ series resistor and a 140 kΩ parallel resistor will produce a monitored window of -5°C to +50°C, typically.

MCP73828

6.1.1.7 CHARGE COMPLETE INTERFACE

The charge complete indicator, CD10, can be utilized to illuminate an LED when the MCP73828 is charging the battery. When the MCP73828 is in constant voltage mode and the charge current has diminished below 10% of $I_{OUT(PEAK)}$, the CD10 pin will transition to a high impedance state. A current limit resistor should be used in series with the LED to establish a nominal LED bias current of 10 mA. The maximum allowable sink current of the CD10 pin is 30 mA.

6.2 PCB Layout Issues

For optimum voltage regulation, place the battery pack as close as possible to the device's V_{OUT} and GND pins. It is recommended to minimize voltage drops along the high current carrying PCB traces.

If the PCB layout is used as a heatsink, adding many vias around the external pass transistor can help conduct more heat to the back-plane of the PCB, thus reducing the maximum junction temperature.

7.0 PACKAGING INFORMATION

7.1 Package Marking Information

8-Lead MSOP

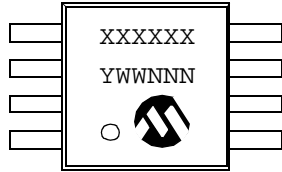

Example:

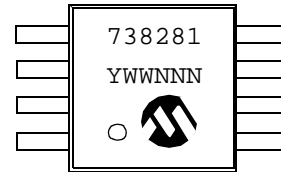

Part Number	Code
MCP73828-4.1VUA	738281
MCP73828-4.2VUA	738282

Legend: XX...X Part Number code + temperature range + voltage (two letter code)*
 Y Year code (last 2 digits of calendar year)
 WW Week code (week of January 1 is week '01')
 NNN Alphanumeric traceability code

Note: In the event the full Microchip part number cannot be marked on one line, it will be carried over to the next line thus limiting the number of available characters for customer specific information.

* Standard OTP marking consists of Microchip part number, year code, week code, and traceability code.

MCP73828

8-Lead Plastic Micro Small Outline Package (MSOP)

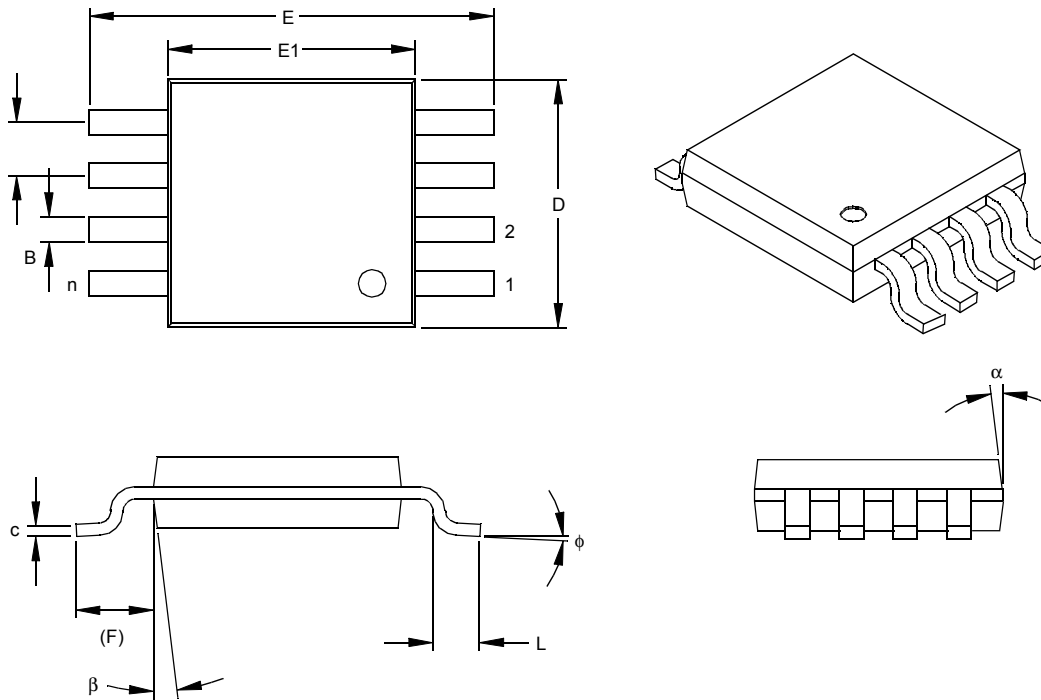

Units		INCHES			MILLIMETERS*		
Dimension Limits		MIN	NOM	MAX	MIN	NOM	MAX
Number of Pins	n		8				8
Pitch	P	.026			0.65		
Overall Height	A			.044			1.18
Molded Package Thickness	A2	.030	.034	.038	0.76	0.86	0.97
Standoff §	A1	.002		.006	0.05		0.15
Overall Width	E	.184	.193	.200	4.67	4.90	5.08
Molded Package Width	E1	.114	.118	.122	2.90	3.00	3.10
Overall Length	D	.114	.118	.122	2.90	3.00	3.10
Foot Length	L	.016	.022	.028	0.40	0.55	0.70
Footprint (Reference)	F	.035	.037	.039	0.90	0.95	1.00
Foot Angle	φ	0		6	0		6
Lead Thickness	c	.004	.006	.008	0.10	0.15	0.20
Lead Width	B	.010	.012	.016	0.25	0.30	0.40
Mold Draft Angle Top	α		7			7	
Mold Draft Angle Bottom	β		7			7	

*Controlling Parameter
§ Significant Characteristic

Notes:

Dimensions D and E1 do not include mold flash or protrusions. Mold flash or protrusions shall not exceed .010" (0.254mm) per side.

Drawing No. C04-111

ON-LINE SUPPORT

Microchip provides on-line support on the Microchip World Wide Web (WWW) site.

The web site is used by Microchip as a means to make files and information easily available to customers. To view the site, the user must have access to the Internet and a web browser, such as Netscape or Microsoft Explorer. Files are also available for FTP download from our FTP site.

Connecting to the Microchip Internet Web Site

The Microchip web site is available by using your favorite Internet browser to attach to:

www.microchip.com

The file transfer site is available by using an FTP service to connect to:

<ftp://ftp.microchip.com>

The web site and file transfer site provide a variety of services. Users may download files for the latest Development Tools, Data Sheets, Application Notes, User's Guides, Articles and Sample Programs. A variety of Microchip specific business information is also available, including listings of Microchip sales offices, distributors and factory representatives. Other data available for consideration is:

- Latest Microchip Press Releases
- Technical Support Section with Frequently Asked Questions
- Design Tips
- Device Errata
- Job Postings
- Microchip Consultant Program Member Listing
- Links to other useful web sites related to Microchip Products
- Conferences for products, Development Systems, technical information and more
- Listing of seminars and events

Systems Information and Upgrade Hot Line

The Systems Information and Upgrade Line provides system users a listing of the latest versions of all of Microchip's development systems software products. Plus, this line provides information on how customers can receive any currently available upgrade kits. The Hot Line Numbers are:

1-800-755-2345 for U.S. and most of Canada, and

1-480-792-7302 for the rest of the world.

013001

MCP73828

READER RESPONSE

It is our intention to provide you with the best documentation possible to ensure successful use of your Microchip product. If you wish to provide your comments on organization, clarity, subject matter, and ways in which our documentation can better serve you, please FAX your comments to the Technical Publications Manager at (480) 792-4150.

Please list the following information, and use this outline to provide us with your comments about this Data Sheet.

To: Technical Publications Manager Total Pages Sent
RE: Reader Response
From: Name _____
Company _____
Address _____
City / State / ZIP / Country _____
Telephone: (_____) _____ - _____ FAX: (_____) _____ - _____

Application (optional):

Would you like a reply? ___Y ___N

Device: **MCP73828** Literature Number: **DS21706A**

Questions:

1. What are the best features of this document?

2. How does this document meet your hardware and software development needs?

3. Do you find the organization of this data sheet easy to follow? If not, why?

4. What additions to the data sheet do you think would enhance the structure and subject?

5. What deletions from the data sheet could be made without affecting the overall usefulness?

6. Is there any incorrect or misleading information (what and where)?

7. How would you improve this document?

8. How would you improve our software, systems, and silicon products?

PRODUCT IDENTIFICATION SYSTEM

To order or obtain information, e.g., on pricing or delivery, refer to the factory or the listed sales office.

<u>PART NO.</u>	<u>-X.X</u>	<u>X</u>	<u>XX</u>
Device	Output Voltage	Temperature Range	Package
Device:	MCP73828: Linear Charge Management Controller		
Output Voltage:	4.1 = 4.1V 4.2 = 4.2V		
Temperature Range:	V = -20°C to +85°C		
Package:	UA = Plastic Micro Small Outline (MSOP), 8-lead		

Examples:

- MCP73828-4.1VUA: Linear Charge Management Controller, 4.1V
- MCP73828-4.2VUA: Linear Charge Management Controller, 4.2V
- MCP73828-4.2VUATR: Linear Charge Management Controller, 4.2V, in tape and reel

Sales and Support

Data Sheets

Products supported by a preliminary Data Sheet may have an errata sheet describing minor operational differences and recommended workarounds. To determine if an errata sheet exists for a particular device, please contact one of the following:

- Your local Microchip sales office
- The Microchip Corporate Literature Center U.S. FAX: (480) 792-7277
- The Microchip Worldwide Site (www.microchip.com)

Please specify which device, revision of silicon and Data Sheet (include Literature #) you are using.

New Customer Notification System

Register on our web site (www.microchip.com/cn) to receive the most current information on our products.

MCP73828

NOTES:

NOTES:

MCP73828

NOTES:

Information contained in this publication regarding device applications and the like is intended through suggestion only and may be superseded by updates. It is your responsibility to ensure that your application meets with your specifications. No representation or warranty is given and no liability is assumed by Microchip Technology Incorporated with respect to the accuracy or use of such information, or infringement of patents or other intellectual property rights arising from such use or otherwise. Use of Microchip's products as critical components in life support systems is not authorized except with express written approval by Microchip. No licenses are conveyed, implicitly or otherwise, under any intellectual property rights.

Trademarks

The Microchip name and logo, the Microchip logo, FilterLab, KEELoQ, MPLAB, PIC, PICmicro, PICMASTER, PICSTART, PRO MATE, SEEVAL and The Embedded Control Solutions Company are registered trademarks of Microchip Technology Incorporated in the U.S.A. and other countries.

dsPIC, ECONOMONITOR, FanSense, FlexROM, fuzzyLAB, In-Circuit Serial Programming, ICSP, ICEPIC, microID, microPort, Migratable Memory, MPASM, MPLIB, MPLINK, MPSIM, MXDEV, PICC, PICDEM, PICDEM.net, rPIC, Select Mode and Total Endurance are trademarks of Microchip Technology Incorporated in the U.S.A.

Serialized Quick Term Programming (SQTP) is a service mark of Microchip Technology Incorporated in the U.S.A.

All other trademarks mentioned herein are property of their respective companies.

© 2002, Microchip Technology Incorporated, Printed in the U.S.A., All Rights Reserved.

 Printed on recycled paper.

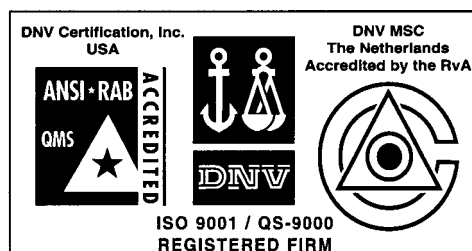

Microchip received QS-9000 quality system certification for its worldwide headquarters, design and wafer fabrication facilities in Chandler and Tempe, Arizona in July 1999. The Company's quality system processes and procedures are QS-9000 compliant for its PICmicro® 8-bit MCUs, KEELoQ® code hopping devices, Serial EEPROMs and microperipheral products. In addition, Microchip's quality system for the design and manufacture of development systems is ISO 9001 certified.