

M57955L

HYBRID IC FOR DRIVING HIGH BETA TRANSISTOR MODULES

DESCRIPTION

M57955L is a Hybrid Integrated Circuit designed for driving High Beta Transistor Modules QM50DY-HB, etc., in an Inverter application. This device operates as an isolation amplifier Transistor Modules due to the electrical isolation between the input and output circuits with a opto-coupler, as well as its driving capability which only requires single power supply.

FEATURES

- Electrical isolation between input and output with integrated opto-coupler. $V_{iso}=2500V_{rms}$
- Applicable with single power supply (7 ~ 9V)
- Applicable with TTL input

APPLICATION

To drive High Beta Transistor Modules for Inverter applications

OUTLINE DRAWING

Dimensions in mm

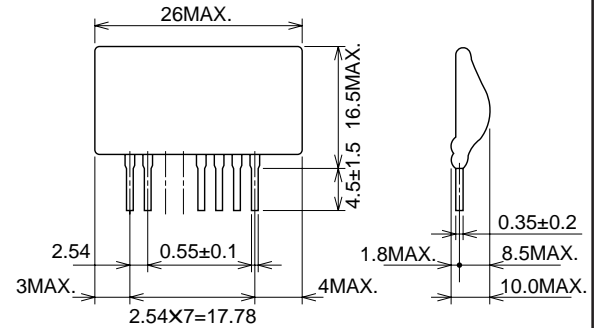

BLOCK DIAGRAM

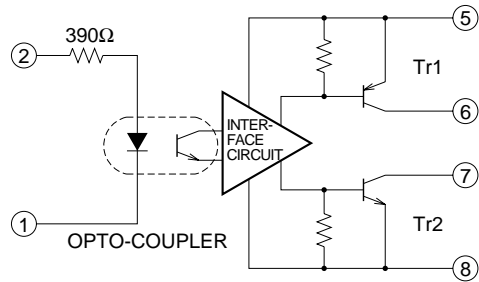

CIRCUIT DIAGRAM

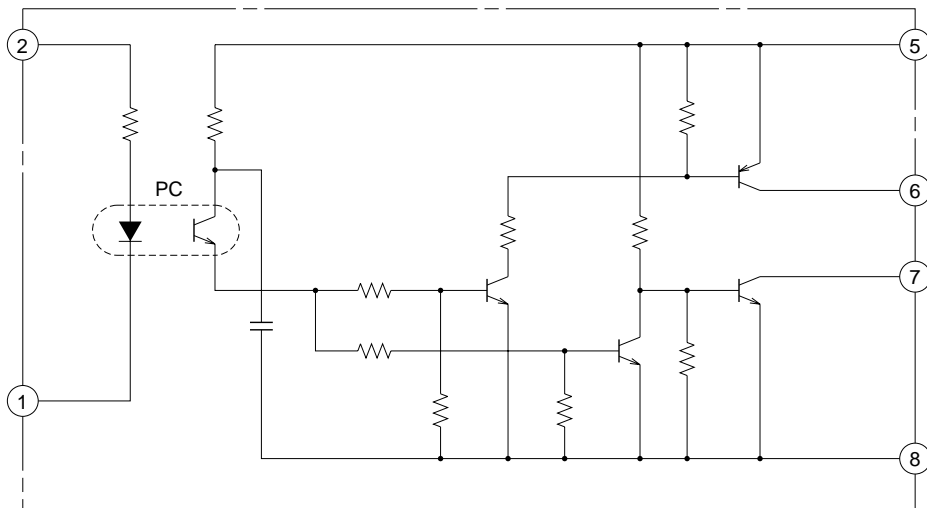

ABSOLUTE MAXIMUM RATINGS (Ta=25°C, unless otherwise noted)

Symbol	Parameter	Conditions	Ratings	Unit
VCC	Supply voltage	DC	12	V
VI	Input voltage		-1 ~ 7	V
IOH	Output voltage	Pulse width 10μs, Freq. 2kHz, peak value	-0.3	A
IOLP			1.3	A
Viso	Isolation voltage	Sinewave voltage 60Hz/min. Ta=25°C	2500	Vrms
Tj	Junction temperature		100	°C
Topg	Operating temperature		-20 ~ +70	°C
Tstg	Storage temperature		-25 ~ +100	°C

ELECTRICAL CHARACTERISTICS (Ta=25°C, VCC=8V, unless otherwise noted)

Symbol	Parameter	Test conditions	Limits			Unit
			Min.	Typ.	Max.	
IiH	"H" input current	VI=5V	-	10	-	mA
IOH	"H" output current	Rext1=36Ω	-	-0.1	-	A
IOLP	"L" output peak current	Cext=47μF, Rext2=0.2Ω	-	1	-	A
PD	Internal power dissipation	IOH=-0.1A, IOLP=1A, f=2kHz, D.F.=50%	-	0.26	-	W
tPLH	"L-H" propagation delay time		-	5	10	μs
tr	"L-H" rise time		-	-	1	μs
tPHL	"H-L" propagation delay time		-	8	15	μs
tf	"H-L" fall time		-	-	2	μs
VIN	Supply voltage	Recommended range	4.75	5	5.25	V
VCC		Recommended range	7	8	9	V

PERFORMANCE CURVES

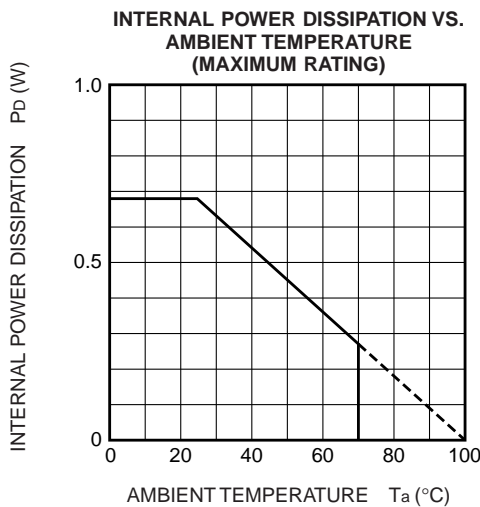
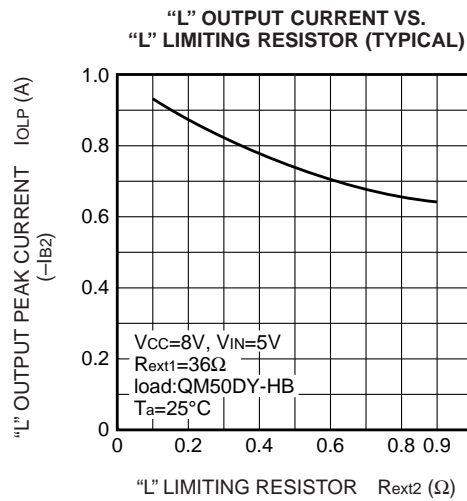
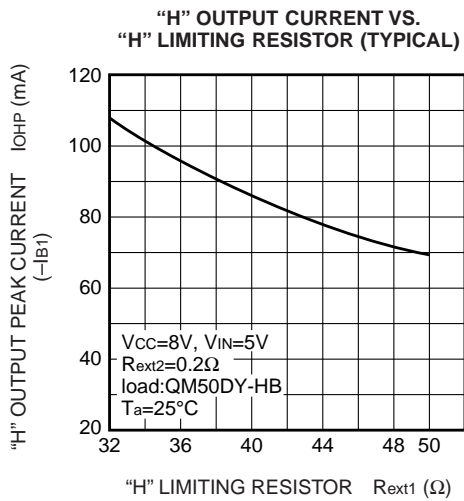
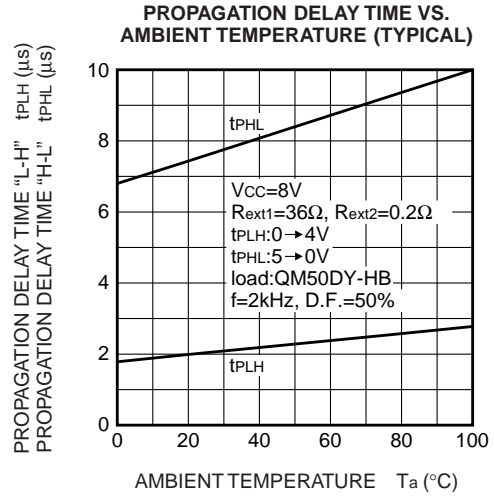
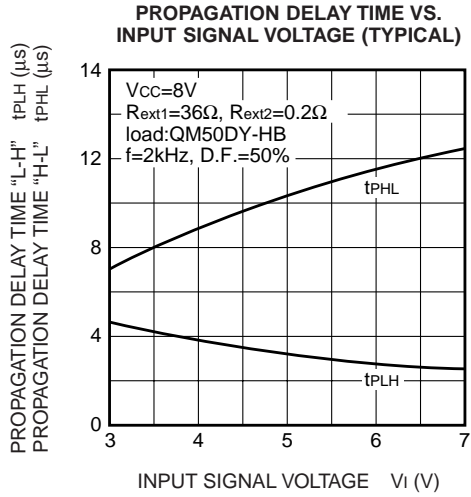

M57955L

HYBRID IC FOR DRIVING HIGH BETA TRANSISTOR MODULES

TEST CIRCUIT AND APPLICATION CIRCUIT EXAMPLE

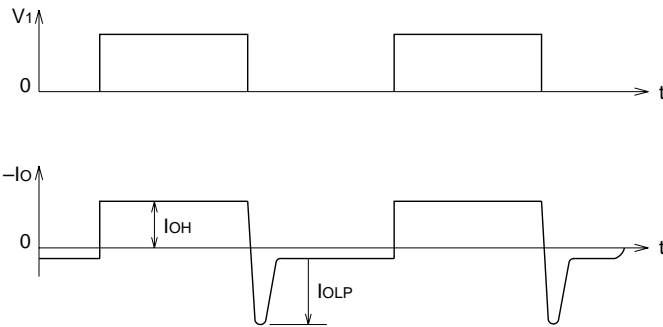
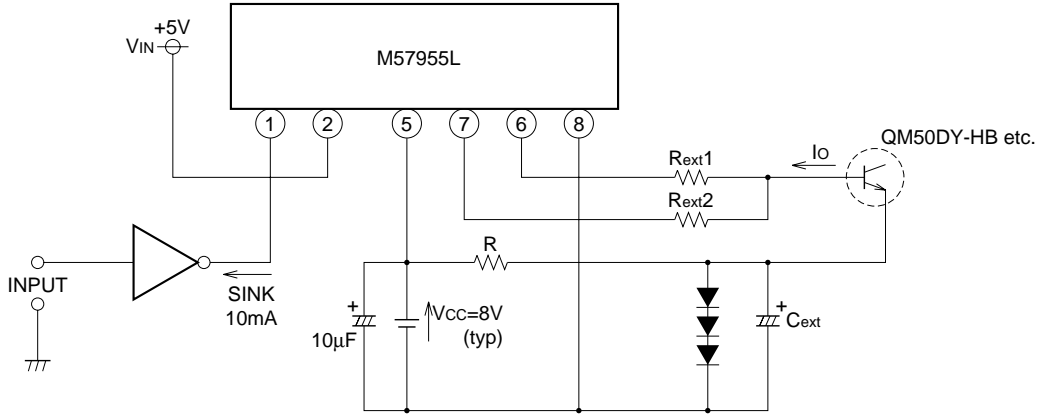

Note: IOH and IOLP correspond to base forward current IB1 and base reverse current IB2 of the transistor modules to be driven respectively.