

Dual 1 Form B Solid State Relay

Features

- Dual Channel (LH1511)
- Isolation Test Voltage 3750 V_{RMS}
- Typical R_{ON} 10 Ω
- Load Voltage 200 V
- Load Current 200 mA
- High Surge Capability
- Linear, AC/DC Operation
- Clean Bounce Free Switching
- Low Power Consumption
- SMD Lead Available on Tape and Reel

Agency Approvals

- UL - File No. E52744
- CSA - Certification 093751
- BSI

Applications

General Telecom Switching

- On/off Hook Control
- Ring Delay
- Dial Pulse
- Ground Start
- Ground Fault Protection

Instrumentation

Industrial Controls

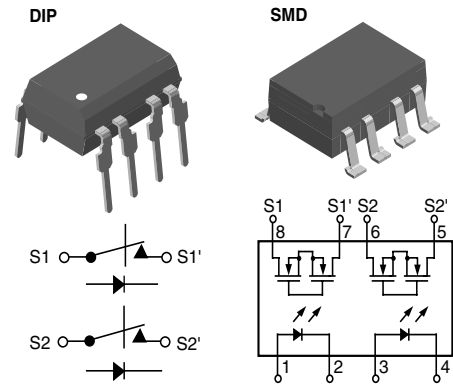

Description

The LH1523 dual 1 Form B relays are SPST normally closed switches that can replace electromechanical relays in many applications. The relays are constructed as a multi chip hybrid device. Actuation control is via an Infrared LED. The output switch is a combination of a photodiode array with MOSFET switches and control circuitry.

Order Information

Part	Remarks
LH1523BAC	SMD-8, Tubes
LH1523BACTR	SMD-8, Tape and Reel
LH1523BB	DIP-8, Tubes

Absolute Maximum Ratings, $T_{amb} = 25\text{ }^{\circ}\text{C}$

Stresses in excess of the absolute Maximum Ratings can cause permanent damage to the device. Functional operation of the device is not implied at these or any other conditions in excess of those given in the operational sections of this document. Exposure to absolute Maximum Ratings for extended periods of time can adversely affect reliability.

SSR

Parameter	Test condition	Symbol	Value	Unit
LED continuous forward current		I_F	50	mA
LED reverse voltage	$I_R \leq 10\text{ }\mu\text{A}$	V_R	5.0	V
DC or peak AC load voltage	$I_L \leq 50\text{ }\mu\text{A}$	V_L	200	V
Continuous DC load current - one pole operating		I_L	200	mA
Continuous DC load current - two poles operating		I_L	140	mA
Peak load current (single shot)	$t = 100\text{ ms}$	I_P	400	mA
Ambient temperature range		T_{amb}	- 40 to + 85	$^{\circ}\text{C}$
Storage temperature range		T_{stg}	- 40 to + 125	$^{\circ}\text{C}$
Pin soldering temperature	$t = 10\text{ s max}$	T_{sld}	260	$^{\circ}\text{C}$
Input/output isolation voltage	$t = 1.0\text{ s, } I_{ISO} = 10\text{ }\mu\text{A max}$	V_{ISO}	3750	V_{RMS}
Pole-to-pole isolation voltage (S1 to S2) ¹⁾ (dry air, dust free, at sea level)			1600	V
Output power dissipation (continuous)		P_{diss}	600	mW

¹⁾ Breakdown occurs between the output pins external to the package.

Electrical Characteristics, $T_{amb} = 25\text{ }^{\circ}\text{C}$

Minimum and maximum values are testing requirements. Typical values are characteristics of the device and are the result of engineering evaluations. Typical values are for information only and are not part of the testing requirements.

Input

Parameter	Test condition	Symbol	Min	Typ.	Max	Unit
LED forward current, switch turn-on	$I_L = \pm 200\text{ mA, } t = 10\text{ ms}$	I_{Fon}	0.2	0.9		mA
LED forward current, switch turn-off	$V_L = \pm 150\text{ V}$	I_{Foff}		1.0	2.0	mA
LED forward voltage	$I_F = 10\text{ mA}$	V_F	1.15	1.22	1.45	V

Output

Parameter	Test condition	Symbol	Min	Typ.	Max	Unit
ON-resistance	$I_F = 0\text{ mA, } I_L = 50\text{ mA}$	R_{ON}		10	15	Ω
OFF-resistance	$I_F = 5.0\text{ mA, } V_L = \pm 100\text{ V}$	R_{OFF}	0.1	1.4		$\text{G}\Omega$
Off-state leakage current	$I_F = 5.0\text{ mA, } V_L = \pm 200\text{ V}$			0.07	1.0	μA
Output capacitance	$I_F = 5.0\text{ mA, } V_L = 50\text{ V}$			50		pF

Transfer

Parameter	Test condition	Symbol	Min	Typ.	Max	Unit
Input/output capacitance	$V_{ISO} = 1.0\text{ V}$	C_{ISO}		3.0		pF
Turn-on time	$I_F = 10\text{ mA}, I_L = 50\text{ mA}$	t_{on}		1.0	3.0	ms
Turn-off time	$I_F = 10\text{ mA}, I_L = 50\text{ mA}$	t_{off}		2.0	3.0	ms

Typical Characteristics ($T_{amb} = 25\text{ }^\circ\text{C}$ unless otherwise specified)

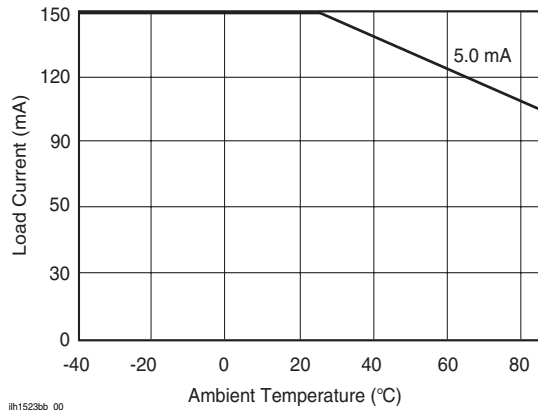
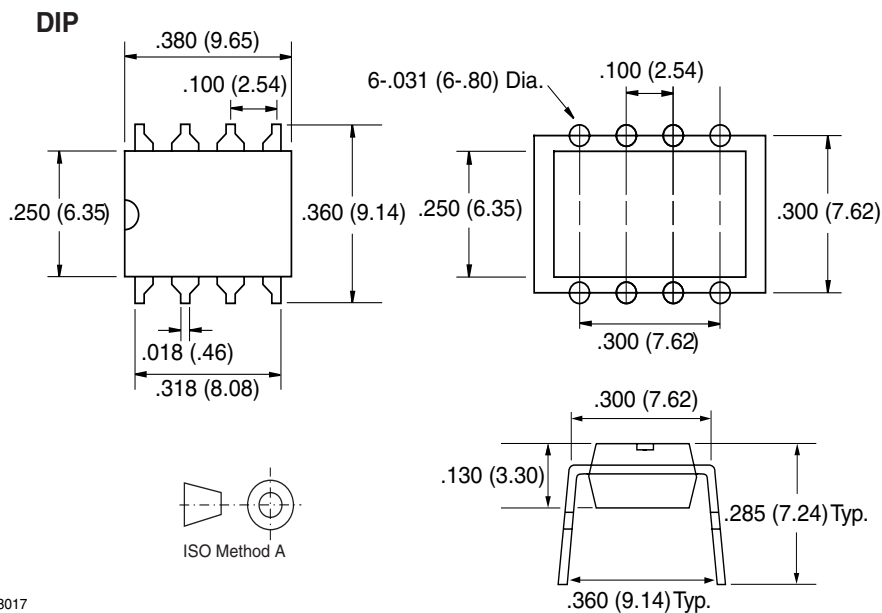

Figure 1. Recommended Operating Conditions

Package Dimensions in Inches (mm)



LH1523BB/ BAC/ BACTR

Vishay Semiconductors



SMD

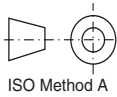
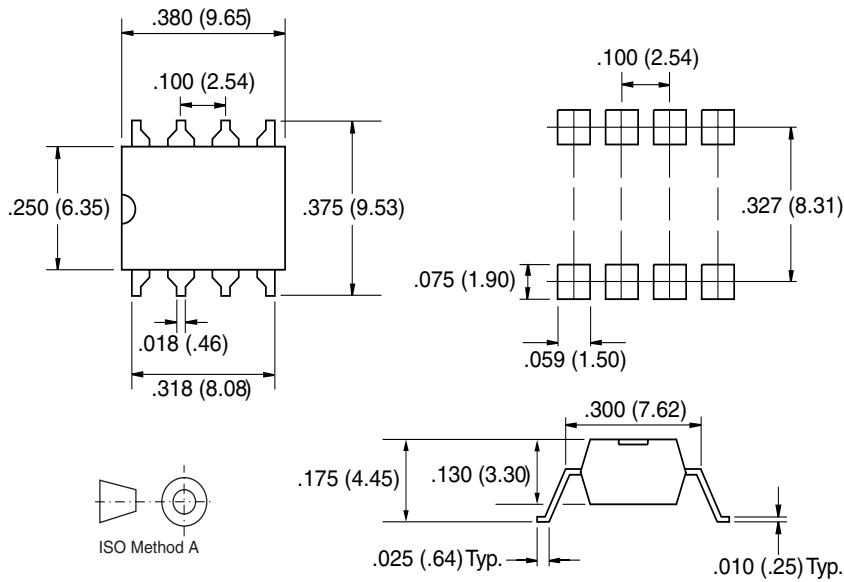

i178018



Ozone Depleting Substances Policy Statement

It is the policy of **Vishay Semiconductor GmbH** to

1. Meet all present and future national and international statutory requirements.
2. Regularly and continuously improve the performance of our products, processes, distribution and operating systems with respect to their impact on the health and safety of our employees and the public, as well as their impact on the environment.

It is particular concern to control or eliminate releases of those substances into the atmosphere which are known as ozone depleting substances (ODSs).

The Montreal Protocol (1987) and its London Amendments (1990) intend to severely restrict the use of ODSs and forbid their use within the next ten years. Various national and international initiatives are pressing for an earlier ban on these substances.

Vishay Semiconductor GmbH has been able to use its policy of continuous improvements to eliminate the use of ODSs listed in the following documents.

1. Annex A, B and list of transitional substances of the Montreal Protocol and the London Amendments respectively
2. Class I and II ozone depleting substances in the Clean Air Act Amendments of 1990 by the Environmental Protection Agency (EPA) in the USA
3. Council Decision 88/540/EEC and 91/690/EEC Annex A, B and C (transitional substances) respectively.

Vishay Semiconductor GmbH can certify that our semiconductors are not manufactured with ozone depleting substances and do not contain such substances.

**We reserve the right to make changes to improve technical design
and may do so without further notice.**

Parameters can vary in different applications. All operating parameters must be validated for each customer application by the customer. Should the buyer use Vishay Semiconductors products for any unintended or unauthorized application, the buyer shall indemnify Vishay Semiconductors against all claims, costs, damages, and expenses, arising out of, directly or indirectly, any claim of personal damage, injury or death associated with such unintended or unauthorized use.

Vishay Semiconductor GmbH, P.O.B. 3535, D-74025 Heilbronn, Germany
Telephone: 49 (0)7131 67 2831, Fax number: 49 (0)7131 67 2423