

# DEVELOPMENT DATA

This data sheet contains advance information and specifications are subject to change without notice.

TDA5709

## RADIAL ERROR SIGNAL PROCESSOR FOR COMPACT DISC PLAYERS

### GENERAL DESCRIPTION

The TDA5709 is a bipolar integrated circuit which provides control signals for the radial motor. These control signals are generated from radial error signals received from a photo-diode signal processor (TDA5708), and velocity control signals from the control processor.

### Features

- Tracking error processor with automatic asymmetry control
- A.G.C. circuitry with automatic start-up and wobble generator
- Tracking control for fast forward/reverse scan, search, repeat and pause functions
- TTL compatible digital input/output
- Digitalized tracking error signal
- Possibility for car application

### QUICK REFERENCE DATA

---

Supply voltage range	$V_{DD}-V_{BB}$	8 to 13 V
Quiescent supply current	$I_Q$	typ. 6 mA
Operating ambient temperature range	$T_{amb}$	-30 to +85 °C

---

### PACKAGE OUTLINE

20-lead DIL; plastic (SOT146).

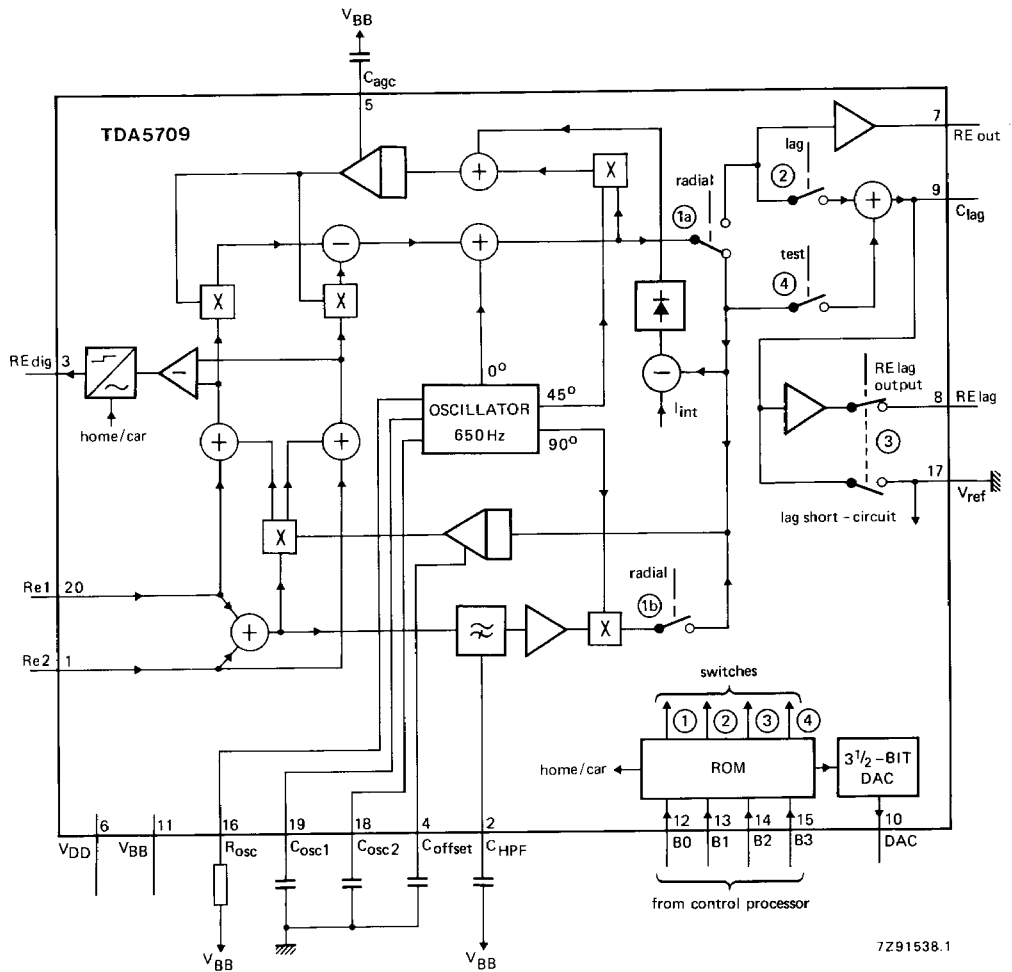

Fig. 1 Block diagram.

**PIN DESCRIPTION**

Pin No.	Symbol	Description
1	Re2	Input for amplified currents from photo diodes D1 and D2
2	C <sub>HPPF</sub>	High-pass filter for Re1 and Re2, used for radial offset control
3	REdig	Digital output of sign (Re2 – Re1)
4	C <sub>offset</sub>	Offset control input for radial offset
5	C <sub>agc</sub>	Gain control input for radial error signal
6	V <sub>DD</sub>	Positive supply voltage
7	REout	Current output of amplified (Re2 – Re1) input currents
8	RElag	Voltage output of integrated (Re2 – Re1) input currents
9	C <sub>lag</sub>	Integrator capacitor for (Re1 – Re2) input currents
10	DAC	Current output for track jumping (3½ bits)
11	V <sub>BB</sub>	Negative supply connection (also substrate connection)
12	B0	Input control bits for off-, catch-, play-status and DAC output current
13	B1	
14	B2	
15	B3	
16	R <sub>osc</sub>	Biassing resistor for oscillator frequency and internal amplitude
17	V <sub>ref</sub>	Intermediate supply voltage
18	C <sub>osc2</sub>	Frequency setting capacitors for oscillator
19	C <sub>osc1</sub>	
20	Re1	Input for amplified currents from photo-diodes D3 and D4

DEVELOPMENT DATA

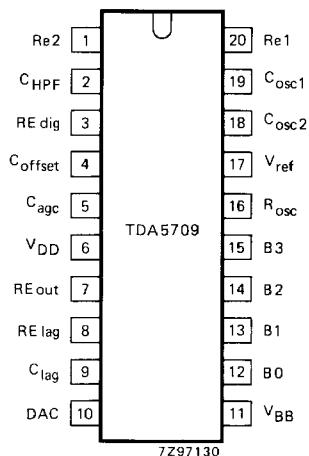

Fig. 2 Pinning diagram.

**RATINGS**

Limiting values in accordance with the Absolute Maximum System (IEC 134)

Supply voltage range ( $V_{DD} - V_{BB}$ )  
pin 6 – pin 11

$V_{DD} - V_{BB}$     -0,3 to + 13 V

Total power dissipation

$P_{tot}$             see Fig. 3

Storage temperature range

$T_{stg}$             -55 to + 150 °C

Operating ambient temperature range

$T_{amb}$             -30 to + 85 °C

Operating junction temperature

$T_j$                 max.        150 °C

**THERMAL RESISTANCE**

From junction to ambient

$R_{th\ j-a}$         =                72 K/W

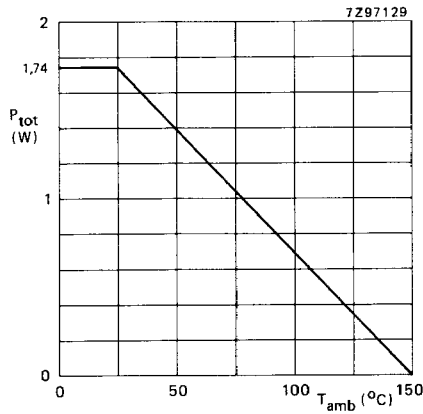

Fig. 3 Power derating curve.

## CHARACTERISTICS

$V_{DD} = +5\text{ V}$ ;  $V_{BB} = -5\text{ V}$ ;  $T_{amb} = 25\text{ }^{\circ}\text{C}$ ;  $V_{ref} = 0\text{ V}$ ;  $R_{osc} = 24\text{ k}\Omega$ ; all voltages with respect to  $V_{ref}$ ; unless otherwise specified.

DEVELOPMENT DATA

parameter	symbol	min.	typ.	max.	unit
<b>Supplies</b>					
Supply voltage					
pin 6 – pin 11 ( $V_{DD} - V_{BB}$ )		8	–	13	V
pin 17 – pin 11 ( $V_{ref} - V_{BB}$ )		4,5	5,0	5,5	V
Quiescent supply current	$I_Q$	–	6	–	mA
<b>REdig output (pin 3)</b>					
Output voltage level					
HIGH (note 1; C)	$V_{REdig}$	$V_{ref} + 2,4$	–	–	V
LOW (note 1; A)	$V_{REdig}$	$V_{ref} - 0,3$	–	$V_{ref} + 0,4$	V
LOW (note 1; B)	$V_{REdig}$	$V_{BB}$	–	$V_{BB} + 0,4$	V
Output current					
sink current (note 1; A or B)	$I_{REdig}$	400	–	–	$\mu\text{A}$
source current (note 1; C)	$I_{REdig}$	–	–150	–50	$\mu\text{A}$
<b>Digital inputs (pins 12 to 15)</b>					
B0, B1, B2 and B3					
Input voltage HIGH (note 2)	$V_B$	$V_{ref} + 2$	–	$V_{DD}$	V
Input voltage LOW (note 2)	$V_B$	$V_{BB} + 2$	–	$V_{ref} + 0,8$	V
Input voltage HIGH (note 3)	$V_B$	$V_{BB} + 2$	–	$V_{DD}$	V
Input voltage LOW (note 3)	$V_B$	$V_{BB} - 0,3$	–	$V_{BB} + 0,8$	V
Input current					
at $V_B = \text{HIGH}$	$I_B$	–	0	–	$\mu\text{A}$
at $V_B = \text{LOW}$	$I_B$	–	–	–10	$\mu\text{A}$
<b>DAC output (pin 10)</b>					
Output voltage range					
at $I_{DAC} = +150\text{ }\mu\text{A}$ (sink current)	$V_{DAC}$	$V_{BB} + 1,5$	–	$V_{DD}$	V
at $I_{DAC} = -150\text{ }\mu\text{A}$ (source current)	$V_{DAC}$	$V_{BB}$	–	$V_{DD} - 1$	V
Output impedance					
at $I_{DAC} = 200\text{ }\mu\text{A}$	$ Z_{DAC} $	–	50	–	M $\Omega$

## CHARACTERISTICS (continued)

parameter	symbol	min.	typ.	max.	unit
<b>DAC output (continued)</b>					
Ratio of output current pin 10 to pin 16 (see Table 1)	$I_{10}/I_{16}$	3,6 -4,6 0,9 -1,2 0,68 -0,86 0,45 -0,58 0,23 -0,29	4 -4 1 -1 0,75 -0,75 0,5 -0,5 0,25 -0,25	4,4 -3,4 1,1 -0,8 0,82 -0,64 0,55 -0,42 0,27 -0,2	
<b>Analogue input (pin 16)</b>					
Input voltage level	$V_{Rosc}$	-	$V_{BB} + 1,2$	-	V
Input current level	$I_{Rosc}$	-	-50	-	$\mu A$
<b>Radial error inputs</b> (Re1 pin 20, Re2 pin 1)					
Input voltage level at $I_{Re1}, I_{Re2} = -105 \mu A$	$V_{Re1}, V_{Re2}$	-	$V_{BB} + 1,4$	-	V
Input current	$I_{Re1}, I_{Re2}$	-	105	-	$\mu A$
Input impedance	$ Z_{Re1} ,  Z_{Re2} $	-	1	-	k $\Omega$
<b>Gain control input (pin 5)</b>					
Input voltage for minimum radial gain	$V_{Cagc}$	-	$V_{BB} + 3,5$	-	V
maximum radial gain	$V_{Cagc}$	-	$V_{BB} + 5,5$	-	V
Input impedance	$ Z_{Cagc} $	-	20	-	M $\Omega$
<b>Offset control (pin 4)</b>					
Output current at $I_{Re1} = I_{Re2} = -105 \mu A$ ; $V_{Cosc1} = V_{Cosc2} = V_{ref}$	$-I_{Coffset}$	-	0,25	-	$\mu A$
Input voltage for maximum amplification Re1	$V_{Coffset}$	-	$V_{ref} - 1$	-	V
minimum amplification Re2	$V_{Coffset}$	-	$V_{ref} - 1$	-	V
minimum amplification Re1	$V_{Coffset}$	-	$V_{ref} + 1$	-	V
maximum amplification Re2	$V_{Coffset}$	-	$V_{ref} + 1$	-	V
Input impedance	$ Z_{Coffset} $	-	30	-	M $\Omega$

DEVELOPMENT DATA

parameter	symbol	min.	typ.	max.	unit
<b>High-pass filter (pin 2)</b>					
Voltage level at $I_{Re1} = I_{Re2} = 0$	$V_{HPF}$	—	$V_{BB} + 2,8$	—	V
Impedance	$ Z_{HPF} $	—	5	—	$k\Omega$
<b>Oscillator</b> ( $C_{Osc1}$ pin 19, $C_{Osc2}$ pin 18)					
Linear input voltage range $V_{Coscl}$ , $V_{Cosc2}$	$V_{Cosc}$	$V_{ref} - 2$	—	$V_{ref} + 2$	V
<b>RElag voltage output (pin 8)</b>					
Output voltage range at $I_{RElag} = +200 \mu A$ (sink current)	$V_{RElag}$	$V_{BB} + 1,5$	—	$V_{DD}$	V
at $I_{RElag} = -200 \mu A$ (source current)	$V_{RElag}$	$V_{BB}$	—	$V_{DD} - 1$	V
Maximum source current output	$I_{RElag}$	—	-2,5	—	mA
Maximum sink current output	$I_{RElag}$	—	4	—	mA
Output impedance (f < 10 kHz) with RElag switched on	$ Z_{RElag} $	—	—	50	$\Omega$
with RElag switched off	$ Z_{RElag} $	1	—	—	$M\Omega$
<b>REout push-pull current output (pin 7)</b>					
Output voltage range at $I_{REout} = +40 \mu A$ (sink current)	$V_{REout}$	$V_{BB} + 1,5$	—	$V_{DD}$	V
at $I_{REout} = -40 \mu A$ (source current)	$V_{REout}$	$V_{BB}$	—	$V_{DD} - 1$	V
Output impedance	$ Z_{REout} $	—	2	—	$M\Omega$
<b>Clag push-pull current output/voltage input (pin 9)</b>					
Output voltage range at $I_{Clag} = +4 \mu A$ (sink current)	$V_{Clag}$	$V_{BB} + 1,5$	—	$V_{DD}$	V
at $I_{Clag} = -4 \mu A$ (source current)	$V_{Clag}$	$V_{BB}$	—	$V_{DD} - 1,5$	V
Output impedance	$ Z_{Clag} $	—	15	—	$M\Omega$

## CHARACTERISTICS (continued)

parameter	symbol	min.	typ.	max.	unit
<b>TRANSFER SPECIFICATIONS</b>					
Oscillator (pins 19, 18)					
(V <sub>osc1</sub> , V <sub>osc2</sub> : -2 V to +2 V)					
<b>Transconductance factor</b>					
$\frac{I_{Cosc2}}{V_{Cosc1}} \cdot R_{osc}$		—	0,48	—	
$\frac{I_{Cosc1}}{V_{Cosc2}} \cdot R_{osc}$		—	-0,48	—	
<b>Amplitude stabilization</b>					
I <sub>osc1</sub> = f(V <sub>osc1</sub> ) at V <sub>Cosc2</sub> = 0					
V <sub>osc1</sub> = 0 V	I <sub>osc1</sub>	—	0,1	—	μA
V <sub>osc1</sub> = +0,87 V	I <sub>osc1</sub>	—	M <sub>2</sub> + 1,4	—	μA
V <sub>osc1</sub> = -0,87 V	I <sub>osc1</sub>	—	M <sub>2</sub> - 1,4	—	μA
V <sub>osc1</sub> = +1,2 V	I <sub>osc1</sub>	—	M <sub>2</sub>	—	μA
V <sub>osc1</sub> = -1,2 V	I <sub>osc1</sub>	—	M <sub>2</sub>	—	μA
V <sub>osc1</sub> = +1,8 V	I <sub>osc1</sub>	—	M <sub>2</sub> - 3,5	—	μA
V <sub>osc1</sub> = -1,8 V	I <sub>osc1</sub>	—	M <sub>2</sub> + 3,5	—	μA
(note 4)					
<b>Amplitude stabilization</b>					
I <sub>osc2</sub> = f(V <sub>osc2</sub> ) at V <sub>Cosc1</sub> = 0					
V <sub>osc2</sub> = 0 V	I <sub>osc2</sub>	—	0,1	—	μA
V <sub>osc2</sub> = +0,87 V	I <sub>osc2</sub>	—	M <sub>3</sub> + 1,4	—	μA
V <sub>osc2</sub> = -0,87 V	I <sub>osc2</sub>	—	M <sub>3</sub> - 1,4	—	μA
V <sub>osc2</sub> = +1,2 V	I <sub>osc2</sub>	—	M <sub>3</sub>	—	μA
V <sub>osc2</sub> = -1,2 V	I <sub>osc2</sub>	—	M <sub>3</sub>	—	μA
V <sub>osc2</sub> = +1,8 V	I <sub>osc2</sub>	—	M <sub>3</sub> - 3,5	—	μA
V <sub>osc2</sub> = -1,8 V	I <sub>osc2</sub>	—	M <sub>3</sub> + 3,5	—	μA
(note 5)					
<b>Transconductance factor</b>					
$\frac{I_{Clag}}{V_{osc1}} \cdot R_{osc}$					
with test on; radial off;					
I <sub>Re1</sub> = I <sub>Re2</sub> = 0					
		—	-0,08	—	



DEVELOPMENT DATA

parameter	symbol	min.	typ.	max.	unit
<b>Transconductance factor</b>					
$\frac{I_{Clag}}{V_{osc1}} \cdot R_{osc}$ with lag on; radial on; $I_{Re1} = I_{Re2} = 0$		—	—0,08	—	
<b>Transconductance factor</b>					
$\frac{I_{REout}}{V_{osc2}} \cdot R_{osc}$ with radial on; $I_{Re1} = I_{Re2} = 0$		—	0	—	
$\frac{I_{REout}}{V_{osc1}} \cdot R_{osc}$ with radial on; $I_{Re1} = I_{Re2} = 0$		—	0,8	—	
<b>Transconductance factor</b>					
$\frac{I_{Coffset}}{V_{Cosc2}} \cdot R_{osc}$ with radial on; $I_{Re1} = I_{Re2} = 0$ at $I_{HPF} = 30 \mu A$		—	0,48	—	
at $I_{HPF} = 0 \mu A$		—	0	—	
at $I_{HPF} = -30 \mu A$		—	-0,48	—	
with radial off; $I_{Re1} = I_{Re2} = 0$ at $I_{HPF} = 30 \mu A$		—	0	—	
<b>Transconductance factor</b>					
$\frac{I_{Coffset}}{V_{Cosc1}} \cdot R_{osc}$ with radial on; $I_{Re1} = I_{Re2} = 0$ at $I_{HPF} = 30 \mu A$		—	0	—	
with radial off; $I_{Re1} = I_{Re2} = 0$ at $I_{HPF} = 30 \mu A$		—	0,08	—	
<b>Transconductance factor</b>					
$\frac{I_{agc}}{V_{Cosc1}} \cdot R_{osc}$ with radial on; $V_{agc} = 0,5 V$ ; $V_{Coffset} = V_{Cosc2} = 0 V$ at $I_{Re1} = -150 \mu A$ ; $I_{Re2} = 0$		—	-0,48	—	
at $I_{Re1} = I_{Re2} = -100 \mu A$		—	note 6	—	
at $I_{Re1} = 0$ ; $I_{Re2} = -150 \mu A$		—	+0,48	—	

## CHARACTERISTICS (continued)

parameter	symbol	min.	typ.	max.	unit
<b>Transconductance factor</b>					
$\frac{I_{agc}}{V_{Cosc2}} \cdot R_{osc}$ with radial on; $V_{agc} = 0,5 \text{ V}$ ; $V_{offset} = V_{Cosc1} = 0 \text{ V}$ at $I_{Re1} = -150 \mu\text{A}$ ; $I_{Re2} = 0$ at $I_{Re1} = I_{Re2} = -100 \mu\text{A}$ at $I_{Re1} = 0$ ; $I_{Re2} = -150 \mu\text{A}$		—	—0,48 0 +0,48	—	
<b>Transfer <math>C_{lag} \rightarrow RE_{lag}</math></b>					
$\frac{V_{RE_{lag}}}{V_{Clag}}$ ; at frequencies < 10 kHz with lag short-circuit off; RE <sub>lag</sub> output on		—	1	—	
<b>Slew rate</b>					
RE <sub>lag</sub> amplifier with lag short-circuit off; RE <sub>lag</sub> output on	SR	—	0,4	—	V/ $\mu\text{s}$
<b>Switch lag short-circuit</b>					
Impedance $\frac{\Delta V_{Clag}}{\Delta I_{Clag}}$ with lag short-circuit on; $ I_{Clag}  < 10 \mu\text{A}$	$ Z_{lag\ sc} $	—	—	1	k $\Omega$
Offset $ V_{Clag} - V_{ref} $ with lag short-circuit on; $I_{Clag} = 0 \mu\text{A}$	$ V_{RE_{lag}} $	—	—	10	mV
<b>Transfer resistance (Re1, Re2 to <math>C_{HPF}</math>)</b>					
$\frac{\Delta V_{CHPF}}{\Delta(I_{Re1} + I_{Re2})}$		—	2,5	—	k $\Omega$
<b>Gain (Re1, Re2 to RE<sub>out</sub>)</b>					
$\frac{\Delta I_{REout}}{\Delta(I_{Re1} - I_{Re2})}$ with lag short-circuit on; radial on; $V_{Coffset} = V_{osc1} = V_{osc2} = 0 \text{ V}$ $V_{agc} = 0,5 \text{ V}$		—	5	—	times

DEVELOPMENT DATA

parameter	symbol	min.	typ.	max.	unit
<b>Offset current RE</b> Offset current with lag short-circuit on; radial on; $V_{\text{Coffset}} = V_{\text{Osc1}} = V_{\text{Osc2}} = 0 \text{ V}$ $V_{\text{agc}} = 0,5 \text{ V}$ at $I_{\text{Re1}} = I_{\text{Re2}} = 100 \mu\text{A}$	$I_{\text{RE}}$	—	0	—	$\mu\text{A}$
<b>Gain (Re1, Re2 to C<sub>agc</sub>)</b> $\frac{\Delta I_{\text{Cagc}}}{\Delta(I_{\text{Re1}} - I_{\text{Re2}})}$ at $I_{\text{Re1}} = -104 \mu\text{A}$ with lag short-circuit on; radial on; $V_{\text{Coffset}} =$ (see note 7); $V_{\text{agc}} = 0,5 \text{ V}$ ; $V_{\text{Cosc1}} = 0 \text{ V}$ ; $V_{\text{Cosc2}} = 1,2 \text{ V}$ ; $\Delta(I_{\text{Re1}} - I_{\text{Re2}}) = 8 \mu\text{A}$		—	0,8	—	times
$\frac{\Delta I_{\text{Cagc}}}{\Delta(I_{\text{Re1}} - I_{\text{Re2}})}$ at $I_{\text{Re2}} = -104 \mu\text{A}$ with lag short-circuit on; radial on; $V_{\text{Coffset}} =$ (note 7); $V_{\text{agc}} = 0,5 \text{ V}$ ; $V_{\text{Cosc1}} = 0 \text{ V}$ ; $V_{\text{Cosc2}} = 1,2 \text{ V}$ ; $\Delta(I_{\text{Re2}} - I_{\text{Re1}}) = 8 \mu\text{A}$		—	-0,8	—	times
<b>Offset current <math>I_{\text{Cagc}}</math></b> Offset current with lag short-circuit on; radial on; $V_{\text{Cosc1}} = 0 \text{ V}$ ; $V_{\text{Cosc2}} = 0 \text{ V}$ $V_{\text{agc}} = 0,5 \text{ V}$ at $I_{\text{Re1}} = I_{\text{Re2}} = -100 \mu\text{A}$	$I_{\text{Cagc}}$	—	0	—	$\mu\text{A}$
<b>Transconductance factor</b> $\frac{\Delta I_{\text{RE}} \cdot V_{\text{RANGE}}}{I_{\text{tot}} \cdot V_{\text{Coffset}}}$ with $V_{\text{Cosc1}} = V_{\text{Cosc2}} = 0 \text{ V}$ ; radial on; $V_{\text{agc}} = -3 \text{ V}$ ; $V_{\text{RANGE}} = 1 \text{ V}$ (internal); $I_{\text{tot}} = I_{\text{Re1}} + I_{\text{Re2}}$ at $I_{\text{Re1}} = I_{\text{Re2}} = -100 \mu\text{A}$		—	2,5	—	
$\frac{\Delta I_{\text{RE}} \cdot V_{\text{RANGE}}}{I_{\text{tot}} \cdot V_{\text{Coffset}}}$ with $V_{\text{Cosc1}} = V_{\text{Cosc2}} = 0 \text{ V}$ ; radial on; $V_{\text{agc}} = V_{\text{BB}}$ ; $V_{\text{RANGE}} = 1 \text{ V}$ (internal); $I_{\text{tot}} = I_{\text{Re1}} + I_{\text{Re2}}$ at $I_{\text{Re1}} = I_{\text{Re2}} = -100 \mu\text{A}$		—	0	—	

CHARACTERISTICS (continued)

parameter	symbol	min.	typ.	max.	unit
Gain control current $I_{agc}$					
$I_{agc}$ with $V_{Cosc1} = V_{Cosc2} = 0\text{ V}$ ; $V_{agc} = 0,5\text{ V}$ ; radial off; $V_{Coffset} = 0\text{ V}$					
at $I_{REtot} = 200\text{ }\mu\text{A}$ ; $I_{Re1} - I_{Re2} = 35\text{ }\mu\text{A}$	$I_{agc}$	—	0	—	$\mu\text{A}$
at $I_{REtot} = 200\text{ }\mu\text{A}$ ; $I_{Re1} - I_{Re2} = 65\text{ }\mu\text{A}$	$I_{agc}$	—	50	—	$\mu\text{A}$

Notes to the characteristics

1. REdig output conditions:

A:  $I_{Re1} > I_{Re2} + 5\text{ }\mu\text{A}$ ;  $V_{Coffset} = V_{ref}$ ; B0 and B1 and B2 and B3  $> V_{BB} + 2,0\text{ V}$ .

B:  $I_{Re1} > I_{Re2} + 5\text{ }\mu\text{A}$ ;  $V_{Coffset} = V_{ref}$ ; B0 or B1 or B2 or B3  $< V_{BB} + 0,8\text{ V}$ .

C:  $I_{Re2} > I_{Re1} + 5\text{ }\mu\text{A}$ ;  $V_{Coffset} = V_{ref}$ ; don't cares for B0, B1, B2 and B3.

2. In the 'home' application all logical inputs B0, B1, B2 and B3 must be  $> V_{BB} + 2\text{ V}$ .

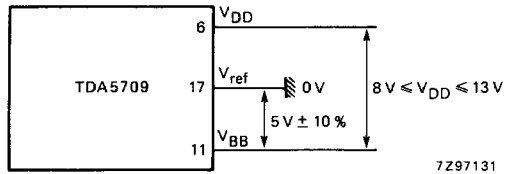

Fig. 4 TDA5709 'home' application.

3. In the 'car' application one or more of the logical inputs B0, B1, B2, B3 must be  $< V_{BB} + 0,8\text{ V}$ .

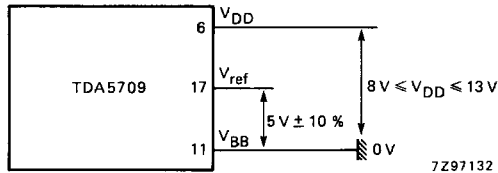

Fig. 5 TDA5709 'car' application.

4.  $M_2$  is the measured value of  $I_{osc1}$  at  $V_{osc1} = 0\text{ V}$ .

5.  $M_3$  is the measured value of  $I_{osc2}$  at  $V_{osc2} = 0\text{ V}$ .

6. Parabolic curve.

7.  $V_{Coffset}$  must be adjusted so that  $I_{Clag} = 4\text{ }\mu\text{A}$ .

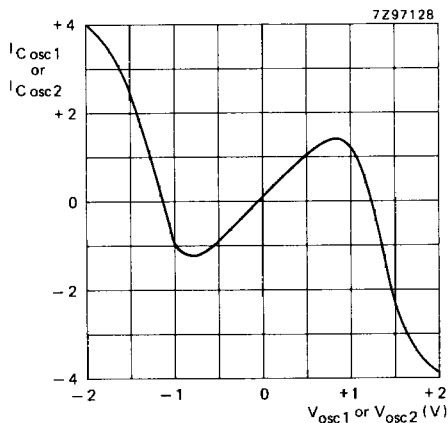

Fig. 6 Amplitude stabilization (typical curve).

Table 1 Truth table for DAC output current

DEVELOPMENT DATA

type names	DAC output ( $\mu A$ )*	logical inputs				internal switches				
		B0	B1	B2	B3	lag	lag s/c	rad	test	output RElag
OFF	0	0	0	0	0	off	on	off	off	off
CATCH	0	0	0	0	1	off	on	on	off	off
PUSH	-200	0	0	1	0	off	on	off	off	off
(kick)	-200	0	0	1	1	off	off	off	off	on
PULL	50	0	1	0	0	off	on	off	off	off
PULL	37,5	0	1	0	1	off	on	off	off	off
PULL	25	0	1	1	0	off	on	off	off	off
PULL	12,5	0	1	1	1	off	on	off	off	off
PUSH	-50	1	0	0	0	off	on	off	off	off
PUSH	-37,5	1	0	0	1	off	on	off	off	off
PUSH	-25	1	0	1	0	off	on	off	off	off
PUSH	-12,5	1	0	1	1	off	on	off	off	off
PULL	200	1	1	0	0	off	on	off	off	off
(kick)	200	1	1	0	1	off	off	off	off	on
play	0	1	1	1	0	on	off	on	off	on
test**	0	1	1	1	1	off	off	off	on	on

Where:

0 = input voltage LOW; 1 = input voltage HIGH.

\* With  $R_{Osc} = 24 \text{ k}\Omega$ .

\*\* Non-proper operating of output REdig if the logical zero is close to  $V_{BB}$ .