

12 to 20 W HI-FI AUDIO POWER AMPLIFIER

The TDA1512A is a monolithic integrated hi-fi audio power amplifier designed for asymmetrical power supplies for mains-fed apparatus.

Special features are:

- Thermal protection
- Low intermodulation distortion
- Low transient intermodulation distortion
- Built-in output current limiter
- Low input offset voltage
- Output stage with low cross-over distortion
- Single in-line (SIL) power package

QUICK REFERENCE DATA

Supply voltage range	V_P	15 to 35 V
Total quiescent current at $V_P = 25$ V	I_{tot}	typ. 65 mA
Output power at $d_{tot} = 0,7\%$ sine-wave power		
$V_P = 25$ V; $R_L = 4 \Omega$	P_O	typ. 13 W
$V_P = 25$ V; $R_L = 8 \Omega$	P_O	typ. 7 W
music power		
$V_P = 32$ V; $R_L = 4 \Omega$	P_O	typ. 21 W
$V_P = 32$ V; $R_L = 8 \Omega$	P_O	typ. 12 W
Closed-loop voltage gain (externally determined)	G_C	typ. 30 dB
Input resistance (externally determined)	R_i	typ. 20 k Ω
Signal-to-noise ratio at $P_O = 50$ mW	S/N	typ. 72 dB
Supply voltage ripple rejection at $f = 100$ Hz	RR	typ. 50 dB

PACKAGE OUTLINES

TDA1512A: 9-lead SIL; plastic power (SOT131).

TDA1512AQ: 9-lead SIL-bent-to-DIL; plastic power (SOT157).

PINNING

1. Non-inverting input
2. Input ground (substrate)
3. Compensation
4. Ground potential
5. Output
6. Positive supply (Vp)
7. Externally connected to pin 6
8. Ripple rejection
9. Inverting input (feedback)

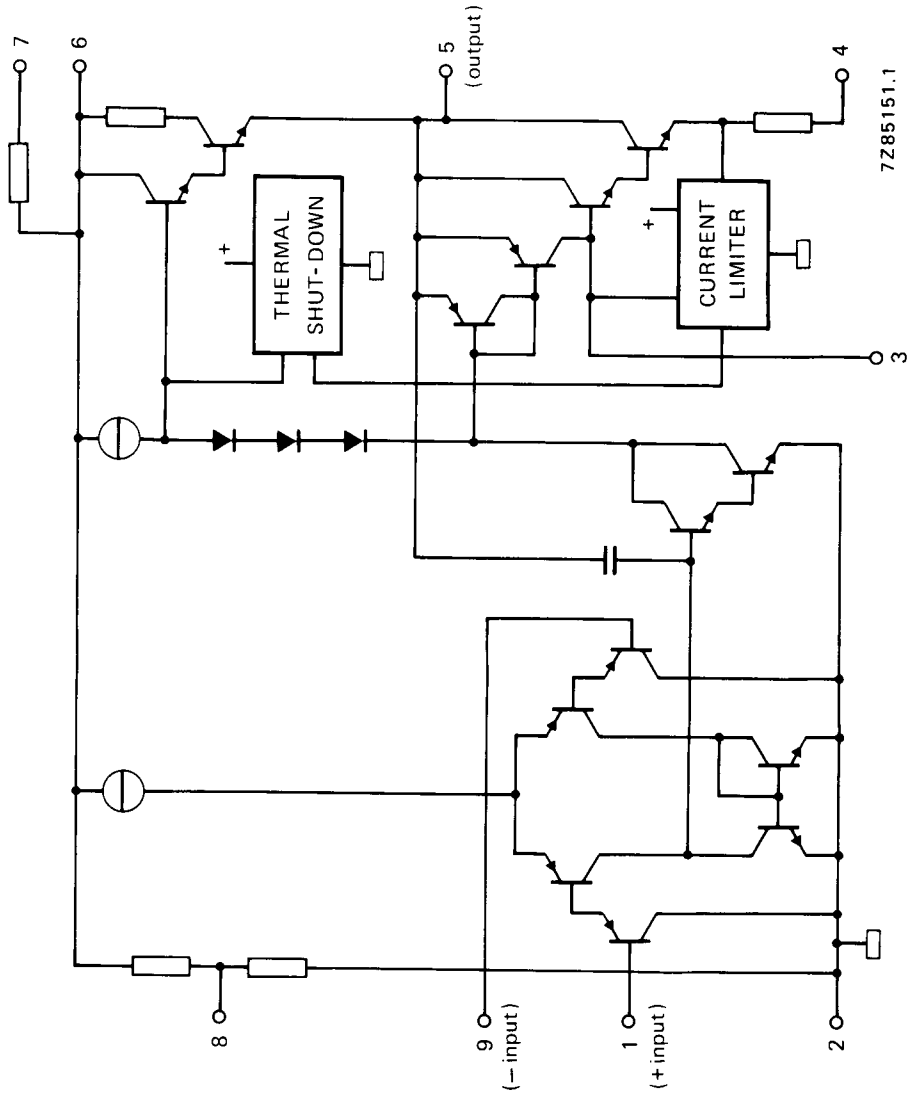

Fig. 1 Simplified internal circuit diagram.

RATINGS

Limiting values in accordance with the Absolute Maximum System (IEC 134)

Supply voltage	V_p	max.	35 V
Repetitive peak output current	I_{ORM}	max.	3,2 A
Non-repetitive peak output current	I_{OSM}	max.	5 A
Total power dissipation	see derating curve Fig. 2		
Storage temperature	T_{stg}	-55 to + 150 °C	
Operating ambient temperature	T_{amb}	-25 to + 150 °C	
A.C. short-circuit duration of load during full-load sine-wave drive $R_L = 0$; $V_p = 30$ V with $R_i = 4 \Omega$	t_{sc}	max.	100 hours

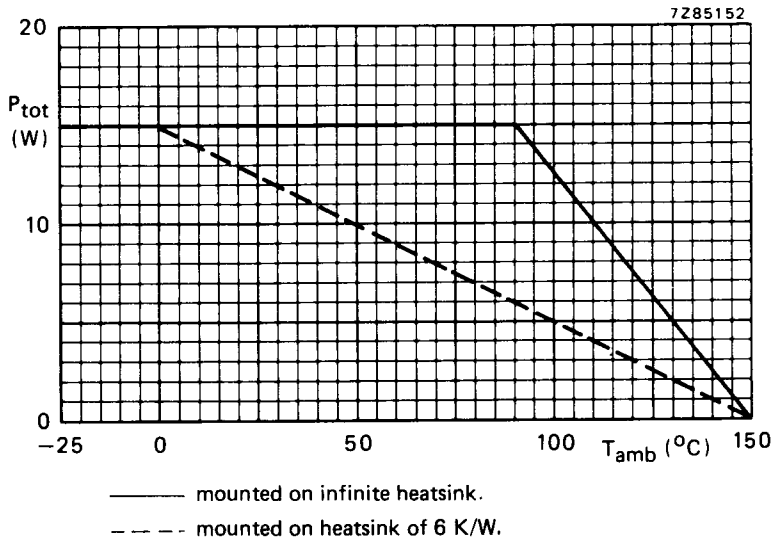

Fig. 2 Power derating curves.

THERMAL RESISTANCE

From junction to mounting base

$R_{th\ j-mb}$	typ.	3 K/W
	\leq	4 K/W

D.C. CHARACTERISTICS

Supply voltage range	V_p		15 to 35 V
Total quiescent current at $V_p = 25$ V	I_{tot}	typ.	65 mA

A.C. CHARACTERISTICS

$V_p = 25$ V; $R_L = 4 \Omega$; $f = 1$ kHz; $T_{amb} = 25$ °C; measured in test circuit of Fig. 3; unless otherwise specified

Output power

sine-wave power at $d_{tot} = 0,7$ %

$R_L = 4 \Omega$	P_O	typ.	13 W
$R_L = 8 \Omega$	P_O	typ.	7 W

music power at $V_p = 32$ V

$R_L = 4 \Omega$; $d_{tot} = 0,7$ %	P_O	typ.	21 W
$R_L = 4 \Omega$; $d_{tot} = 10$ %	P_O	typ.	25 W
$R_L = 8 \Omega$; $d_{tot} = 0,7$ %	P_O	typ.	12 W
$R_L = 8 \Omega$; $d_{tot} = 10$ %	P_O	typ.	15 W

Power bandwidth; $-1,5$ dB; $d_{tot} = 0,7$ %	B		40 Hz to 16 kHz
---	---	--	-----------------

Voltage gain

open-loop	G_O	typ.	74 dB
closed-loop	G_C	typ.	30 dB

Input resistance (pin 1)

R_i	>	100 k Ω
-------	---	----------------

Input resistance of test circuit (Fig. 3)

R_i	typ.	20 k Ω
-------	------	---------------

Input sensitivity

for $P_O = 50$ mW	V_i	typ.	16 mV
for $P_O = 10$ W	V_i	typ.	210 mV

Signal-to-noise ratio

at $P_O = 50$ mW; $R_S = 2$ k Ω ; $f = 20$ Hz to 20 kHz; unweighted	S/N	>	68 dB
---	-----	---	-------

weighted; measured according to IEC 173 (A-curve)	S/N	typ.	76 dB
--	-----	------	-------

Ripple rejection at $f = 100$ Hz

RR	typ.	50 dB
----	------	-------

Total harmonic distortion at $P_O = 10$ W

d_{tot}	typ.	0,1 %
	<	0,3 %

Output resistance (pin 5)

R_O	typ.	0,1 Ω
-------	------	--------------

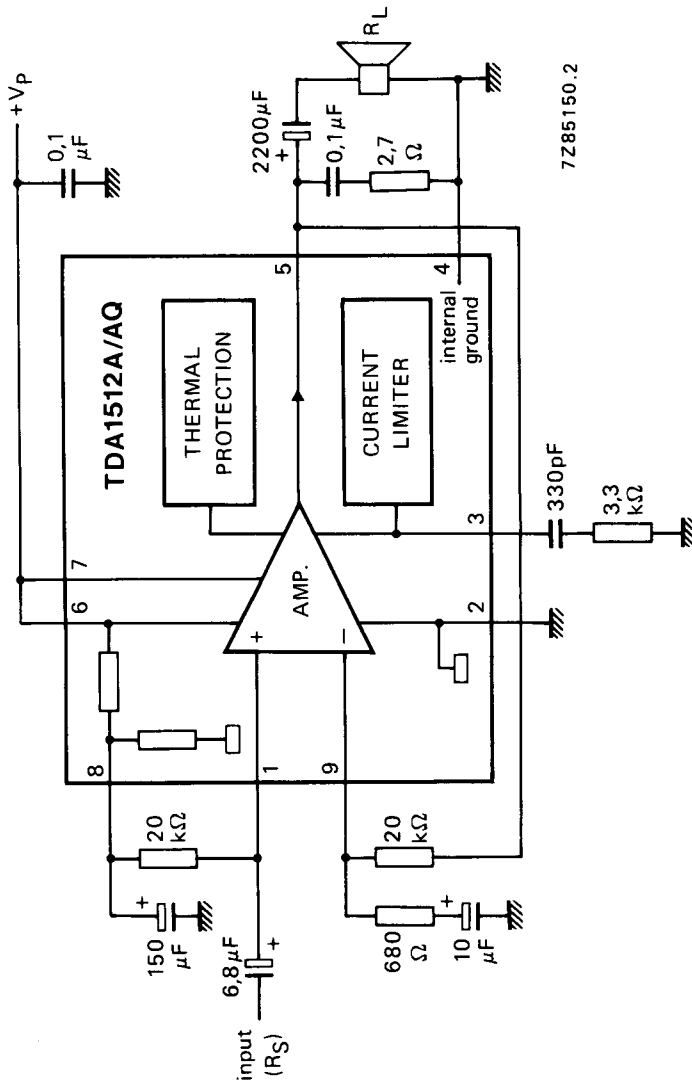

Fig. 3 Test circuit.

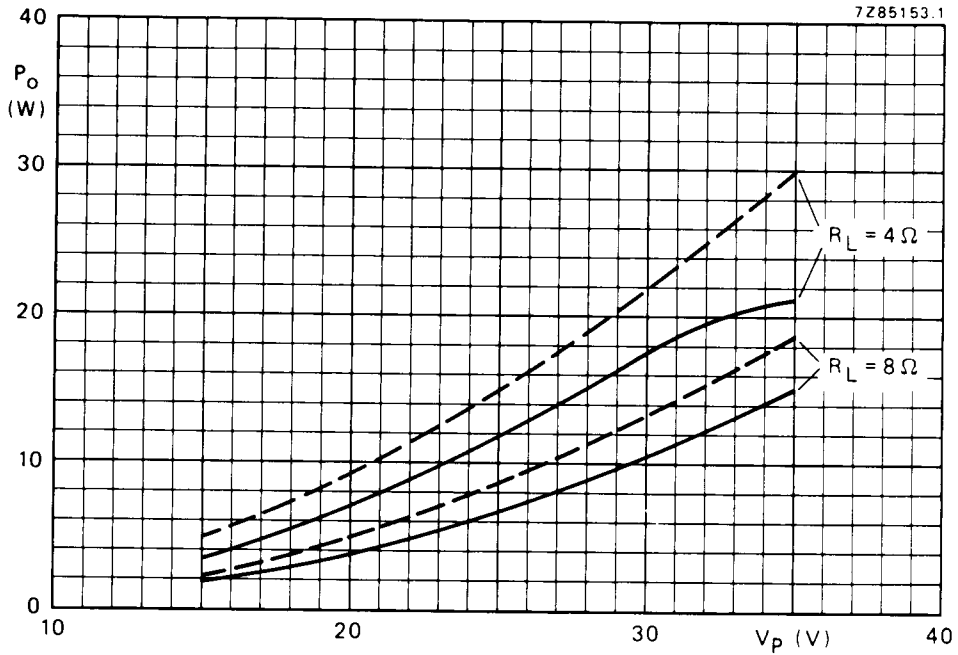

Fig. 4 Output power as a function of the supply voltage; $f = 1 \text{ kHz}$;
— $d_{tot} = 0.7\%$; - - - $d_{tot} = 10\%$.

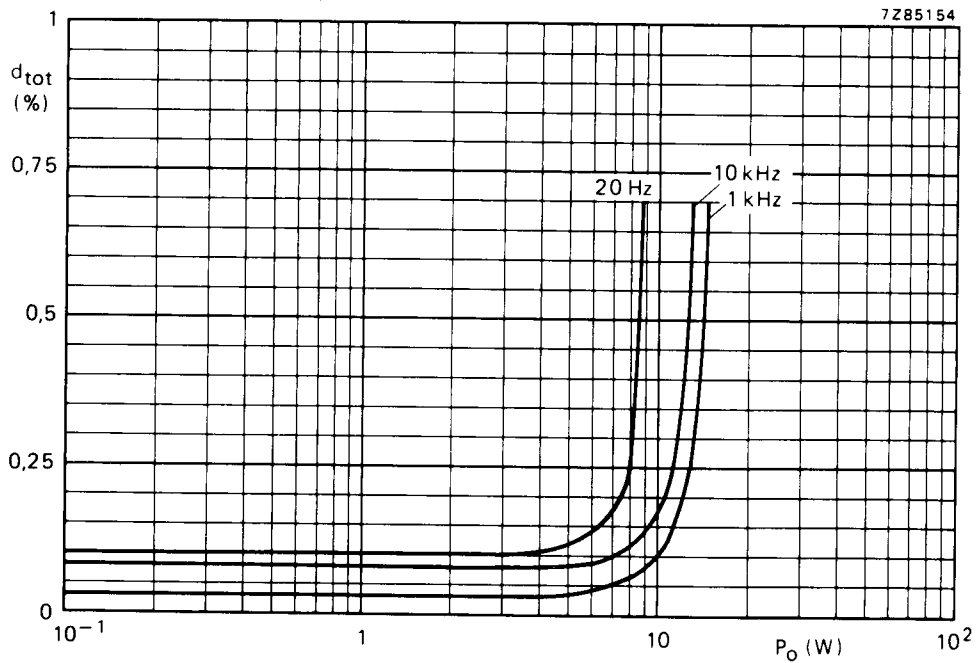

Fig. 5 Total harmonic distortion as a function of the output power.