

TOSHIBA BIPOLAR LINEAR INTEGRATED CIRCUIT SILICON MONOLITHIC

TA8008F

VOLTAGE REGULATOR WITH WAKE UP TIMER

The TA8008F is designed for microcomputer systems. It incorporates a highly accurate constant-voltage power supply ($5 \pm 0.15V$), wake up timer which can make low current consumption of the system and various system reset function in a chip.

The wake up timer starts CPU system and etc. in periodically and decrease average current consumption. Starting period can be set with external capacitor.

The watchdog timer works while the system is working. The TA8008F incorporates current limiter of 600mA (Typ.), so it is possible to build the system easily without external protection circuits and detection resistors.

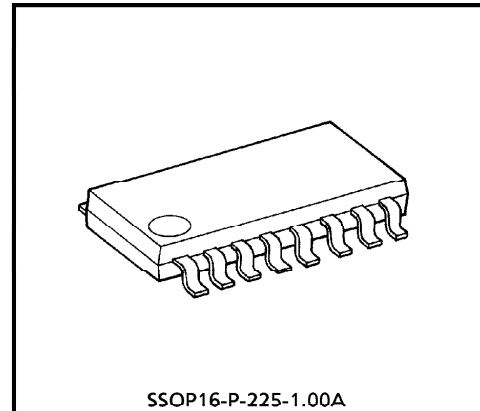

Weight : 0.14g (Typ.)

FEATURES

- Accurate output : $5 \pm 0.15V$ ($T_a = -40 \sim 105^\circ C$)
- Low standby current : 0.95mA (Max.)
- Wake up timer incorporated : It is possible to set the periodical time with external capacitor.
- Reset function : Power on reset (The power on reset function can be selected for its function through the SE pin.)
Watchdog reset
- Current limiter incorporated : 600mA (Typ.)
- External parts are a few.
- Plastic SSOP 16 Pin Package.

961001EBA2

- TOSHIBA is continually working to improve the quality and the reliability of its products. Nevertheless, semiconductor devices in general can malfunction or fail due to their inherent electrical sensitivity and vulnerability to physical stress. It is the responsibility of the buyer, when utilizing TOSHIBA products, to observe standards of safety, and to avoid situations in which a malfunction or failure of a TOSHIBA product could cause loss of human life, bodily injury or damage to property. In developing your designs, please ensure that TOSHIBA products are used within specified operating ranges as set forth in the most recent products specifications. Also, please keep in mind the precautions and conditions set forth in the TOSHIBA Semiconductor Reliability Handbook.
- The products described in this document are subject to foreign exchange and foreign trade control laws.
- The information contained herein is presented only as a guide for the applications of our products. No responsibility is assumed by TOSHIBA CORPORATION for any infringements of intellectual property or other rights of the third parties which may result from its use. No license is granted by implication or otherwise under any intellectual property or other rights of TOSHIBA CORPORATION or others.
- The information contained herein is subject to change without notice.

BLOCK DIAGRAM AND PIN LAYOUT

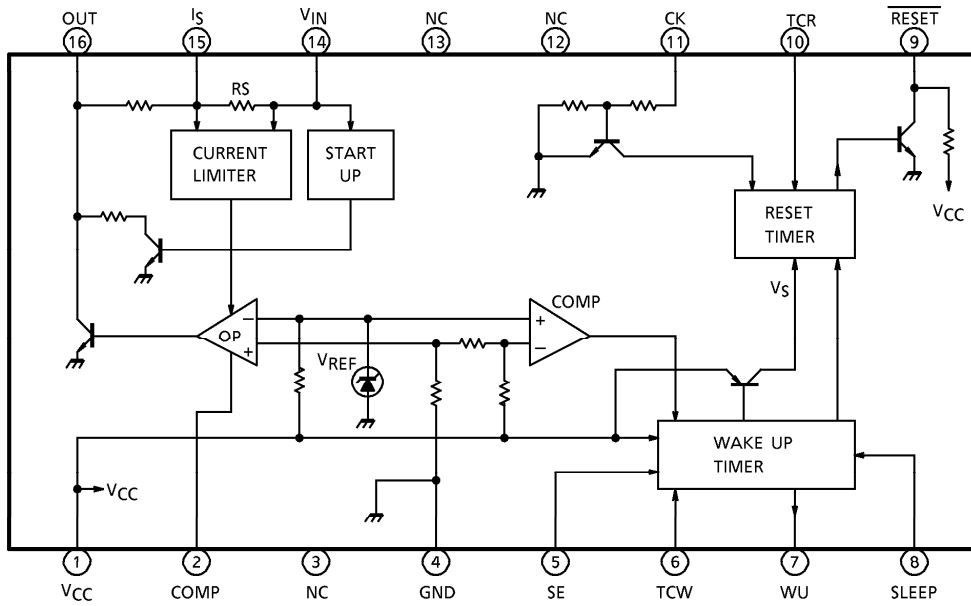

PIN DESCRIPTION

PIN No.	SYMBOL	DESCRIPTION
1	V _{CC}	5V constant-voltage pin. Power supply pin for inside circuits. The output voltage 5V is also detected.
2	COMP	Phase compensation pin for output stabilization.
3	NC	Not connected.
4	GND	Grounded.
5	SE	The power on reset function is controlled by this pin when the mode is changed active from standby. SE = H : The reset signal is output on every mode's change (standby→active). SE = L : The reset signal is output only when the power supply starts.
6	TCW	Pin for setting a time for the wake up timer. A capacitor is connected to this pin. It incorporates a 10 μ A (Typ.) constant-current, so external resistor is not needed. The wake up time is approximately calculated by the following formula : TWU = 400 × CW (ms) TWU : wake up time, CW : capacitor connected to 6 pin (μ F)
7	WU	This pin outputs the wake up signal which starts the CPU. When 8 pin receives the sleep signal, this pin outputs wake up signal after TWU time which is set by TCW.
8	SLEEP	When the CPU goes into sleep mode, this pin receives the signal which comes from the CPU. If wake up function is not necessary : • Connected to "L" 5V power supply and all reset timers work. • Connected to "H" Become to be standby mode.
9	$\overline{\text{RESET}}$	Power-on / watchdog timer reset pin. • Generates a reset signal which is determined by the C of the TCR pin. • Intermittently generates reset pulses if no clock is supplied to the CK pin. The $\overline{\text{RESET}}$ signal is the output from the collector of an NPN transistor with a pull-up resistor.
10	TCR	Pin for setting a time for the reset timer and watchdog timer. It connects to a resistor and capacitor. The charging and discharging are done with internal 100 μ A (Typ.) constant-current and 1k Ω resistor, so external pull-up resistor and etc. are not needed.
11	CK	Clock input pin for the watchdog timer. If it is used for a power-on reset timer only, it is connected to the 9 pin ($\overline{\text{RESET}}$).
12, 13	NC	Not connected.
14	V _{IN}	Power supply pin for the current limiter and the startup circuit which turns on 5V power.
15	I _S	Detection pin for the current limiter. It incorporates current detection resistor (30m Ω) between V _{IN} and I _S . The load current exceeding 600mA activates the current limiter.
16	OUT	Connected to the base of an external PNP transistor so that the output voltage is stabilized. Power supply design suitable for particular load capacities is thus possible. Since recommended maximum I _{OUT} is 8mA, an output current of 320mA is assured if the external transistor has an h _{FE} of 40 or more.

TIMING CHART

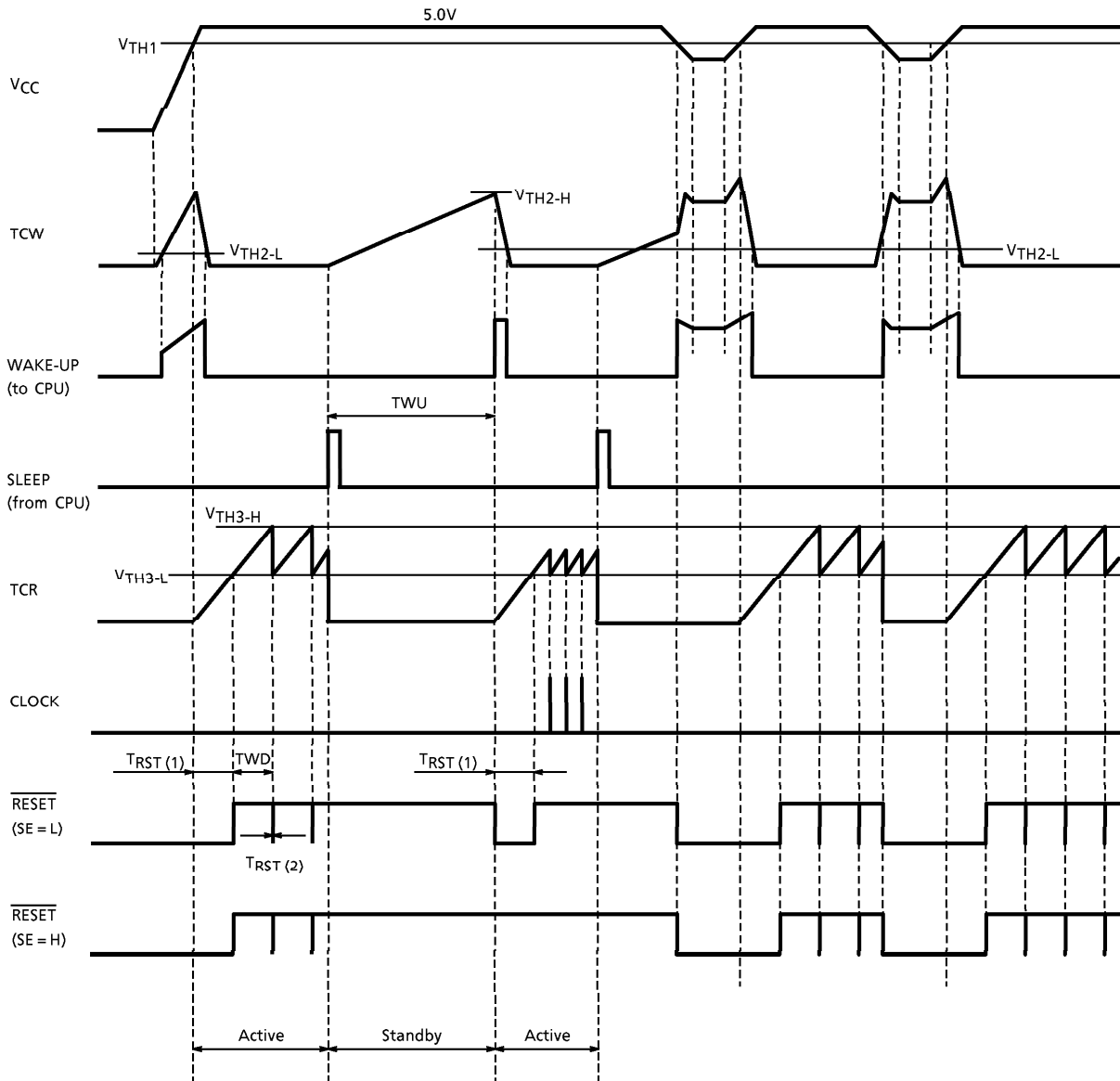

MAXIMUM RATINGS (Ta = 25°C)

CHARACTERISTIC	SYMBOL	PIN	RATING	UNIT
Input Voltage	V _{IN1}	V _{IN} , I _S	60 (1s)	V
	V _{IN2}	CK, SLEEP	-5~V _{CC}	
	V _{IN3}	SE	-0.5~V _{CC}	
Output Current	I _{OUT1}	OUT	10	mA
	I _{OUT2}	WU	-1	
	I _{OUT2}	$\overline{\text{RESET}}$	2	
Output Voltage	V _{OUT1}	OUT	60 (1s)	V
	V _{OUT2}	$\overline{\text{RESET}}$	V _{CC}	
Power Dissipation	P _D	—	600	mW
Operating Temperature	T _{opr}	—	-40~105	°C
Storage Temperature	T _{stg}	—	-55~150	°C
Lead Temperature Time	T _{sol}	—	260 (10s)	°C

ELECTRICAL CHARACTERISTICS ($V_{IN} = 6\sim 18V$, $I_{LOAD} = 10mA$, $T_a = -40\sim 105^\circ C$)

(1) DC CHARACTERISTICS

CHARACTERISTICS	SYMBOL	PIN	TEST CONDITION	MIN.	TYP.	MAX.	UNIT
Output Voltage	V_{REG}	V_{CC}		4.85	5.0	5.15	V
Line Regulation		V_{CC}	$V_{IN} = 5.5\sim 40V$	—	0.1	0.5	%
Load Regulation		V_{CC}	$I_{LOAD} = 1\sim 50mA$	—	0.1	0.5	%
Temperature Coefficient		V_{CC}		—	0.01	—	% / °C
Input Current	I_{IN}	SE, SLEEP	$V_{IN} = 0\sim 5V$	—	—	5	μA
Input Voltage	V_{IH}	SE, SLEEP		2	—	—	V
	V_{IL}			—	—	0.3	
Output Leakage Current	I_{LEAK}	RESET	$V_{OUT} = 5V$	—	—	5	μA
		WU	$V_{OUT} = 0V$	-5	—	—	
Output Voltage	V_{OL}	RESET	$I_{OL} = 1mA$	—	—	0.5	V
	V_{OH}	WU	$I_{OH} = 1mA$	$V_{CC} - 0.5$	—	—	
Input Current	I_{IN}	TCW, TCR	$V_{IN} = 0\sim 3.5V$	-3	—	3	μA
Threshold Voltage	V_{TH2-H}	TCW		—	$V_{REG} \times 80\%$	—	V
	V_{TH2-L}			—	$V_{REG} \times 20\%$	—	
	V_{TH3-H}	TCR		—	$V_{REG} \times 80\%$	—	
	V_{TH3-L}			—	$V_{REG} \times 40\%$	—	
Input Current	I_{IN}	CK	$V_{IN} = 5V$	—	0.17	0.35	mA
Input Voltage	V_{IH}	CK		2	—	—	V
	V_{IL}			—	—	0.5	
Reset Detect Voltage	V_{TH1}			$V_{REG} \times 89\%$	$V_{REG} \times 92\%$	$V_{REG} \times 95\%$	
Standby Current	I_{ST}	V_{CC}		—	0.5	0.95	mA
Power Supply Current	I_{CC}	V_{CC}		—	2.8	5.0	mA
Current Limiter Detection	I_{LMT}	I_S		—	600	—	mA

(2) AC CHARACTERISTICS

CHARACTERISTICS	SYMBOL	PIN	TEST CONDITION	MIN.	TYP.	MAX.	UNIT
Wake Up Timer	TWU	WU		$275 \times CW$	$400 \times CW$	$580 \times CW$	ms
Watchdog Timer	TWD	RESET		$13 \times CR$	$20 \times CR$	$30 \times CR$	
Reset Timer (1)	$T_{RST(1)}$		$10 \times CR$	$16 \times CR$	$24 \times CR$		
Reset Timer (2)	$T_{RST(2)}$		$0.3 \times CR$	$0.7 \times CR$	$1.5 \times CR$		
Sleep Pulse Width	T_{SLEEP}	SLEEP		3	—	—	μs
Clock Pulse Width	TW	CK		3	—	—	

* UNIT ; CR, CW (μF)

EXAMPLE OF APPLICATION CIRCUIT

1. Example for using the wake up signal to start the CPU system.

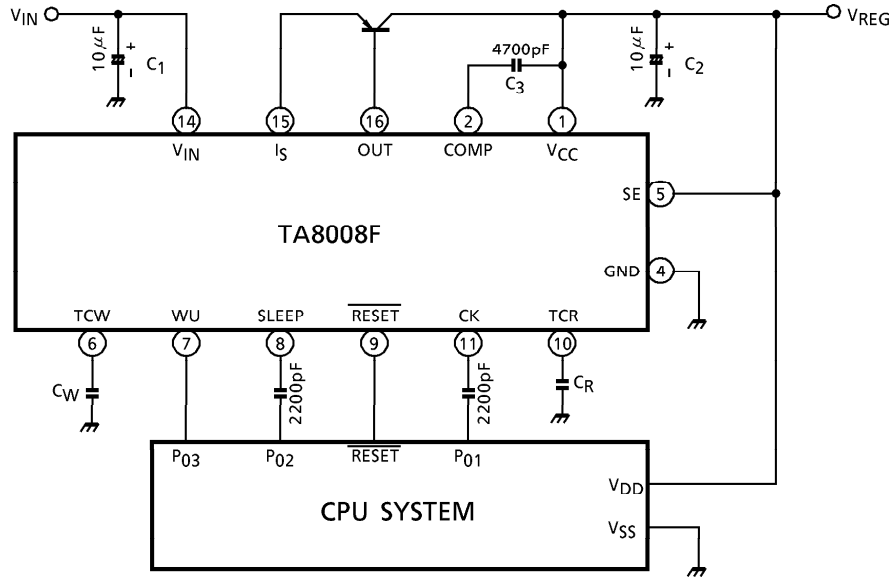

2. Example for using the reset signal to start the CPU system.

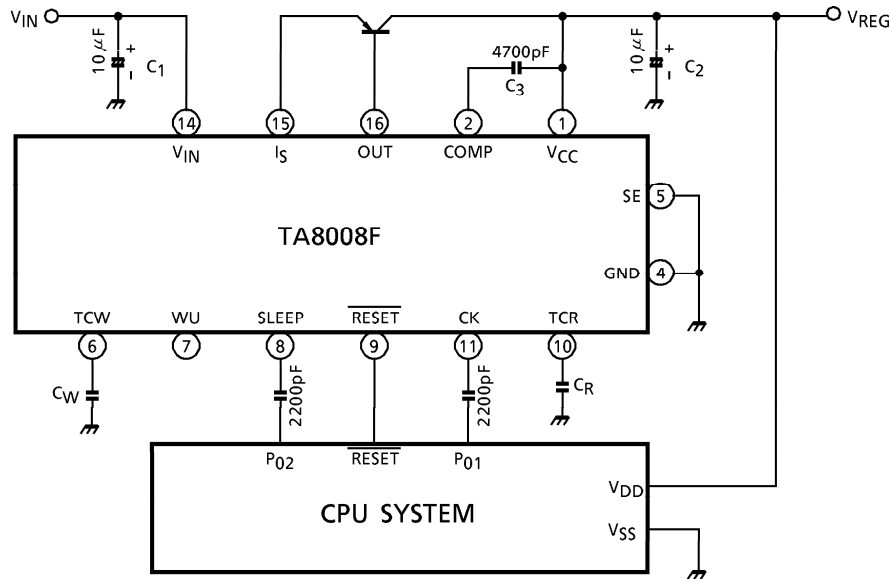

(*) Cautions for wiring

1. C₁ and C₂ are for absorbing disturbance, noise, etc. Connect them as close as the IC as possible.
2. C₃ is for phase compensation. Also, connect C₃ close to the IC.

TYPICAL CHARACTERISTIC

INPUT - OUTPUT CHARACTERISTIC (RL = 500Ω)

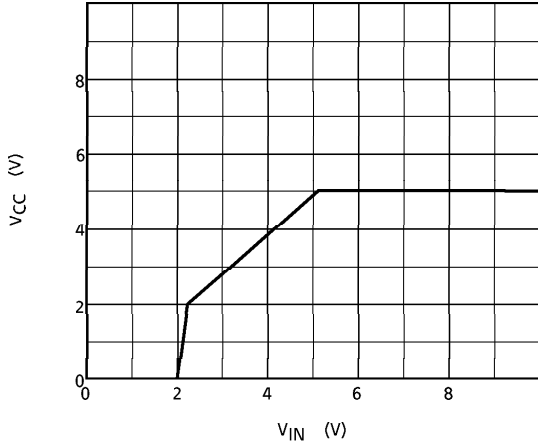

RESET OUTPUT CHARACTERISTIC

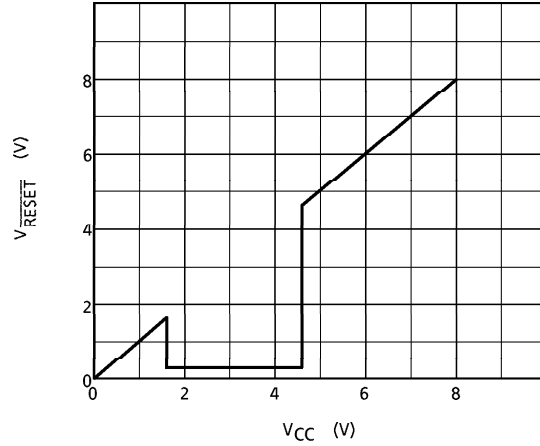

TWU TIME COEFFICIENT CHARACTERISTIC

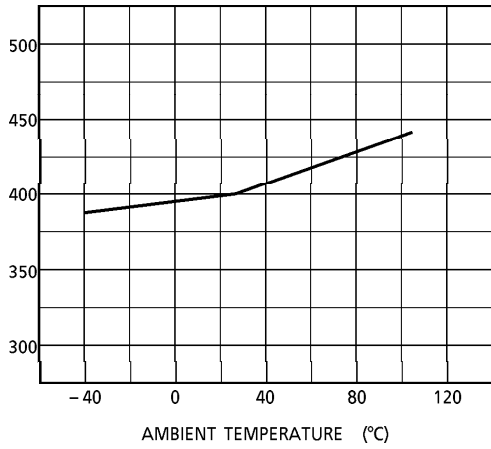

TWD TIME COEFFICIENT CHARACTERISTIC

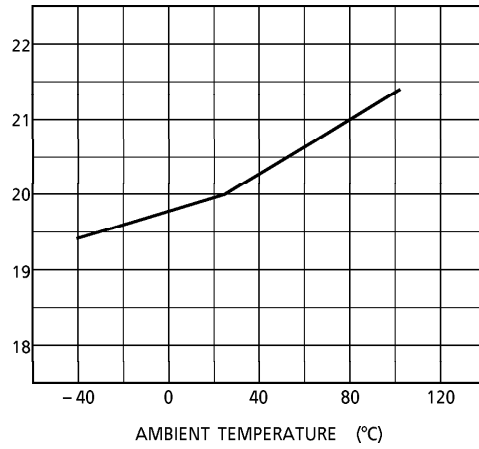

TRST (1) TIME COEFFICIENT CHARACTERISTIC

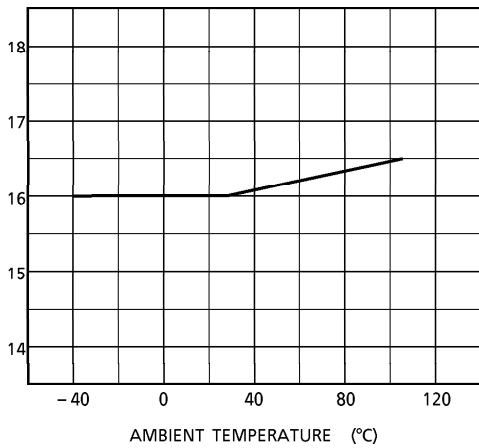

OUTLINE DRAWING
SSOP16-P-225-1.00A

Unit : mm

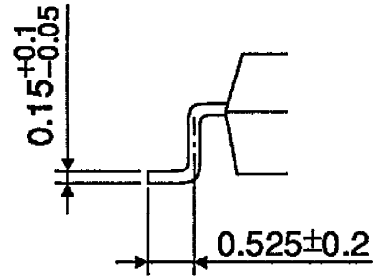
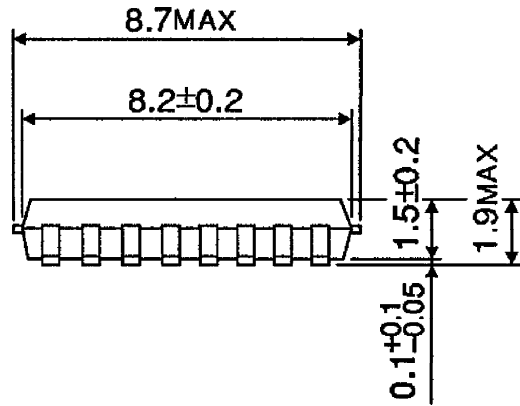
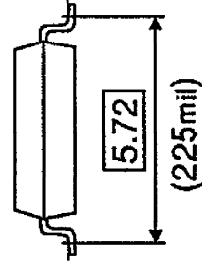
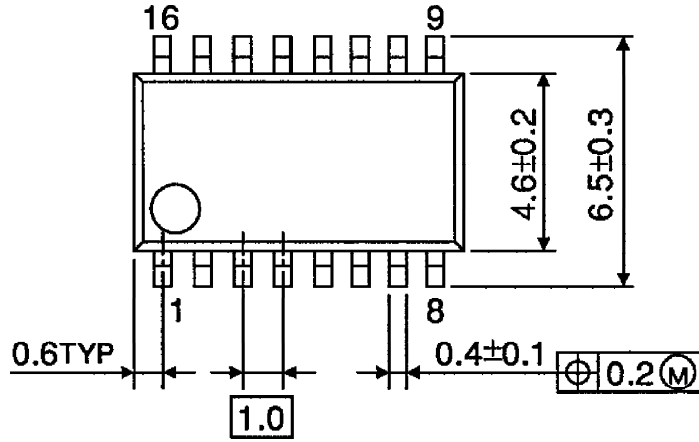

Weight : 0.14g (Typ.)