

Precision Air-Core Tach/Speedo Driver with Short Circuit Protection

Description

The CS-8191 is specifically designed for use with 4 quadrant air-core meter movements. The IC includes an input comparator for sensing input frequency such as vehicle speed or engine RPM, a charge pump for frequency to voltage conversion, a bandgap reference for stable operation and a function generator with sine and cosine ampli-

fiers that differentially drive the motor coils.

The CS-8191 has a higher torque output and better output signal symmetry than other competitive parts (CS-289, and LM1819). It is protected against short circuit and overvoltage (60V) fault conditions. Enhanced circuitry permits functional operation down to 8V.

Absolute Maximum Ratings

Supply Voltage ($\leq 100\text{ms}$ pulse transient).....	$V_{CC} = 60\text{V}$
(continuous).....	$V_{CC} = 24\text{V}$
Operating Temperature Range	-40°C to $+105^{\circ}\text{C}$
Junction Temperature Range	-40°C to $+150^{\circ}\text{C}$
Storage Temperature Range	-55°C to $+165^{\circ}\text{C}$
Electrostatic Discharge (Human Body Model)	4kV
Lead Temperature Soldering	
Wave Solder (through hole styles only)	10 sec. max, 260°C peak
Reflow (SMD styles only)	60 sec. max above 183°C , 230°C peak

Block Diagram

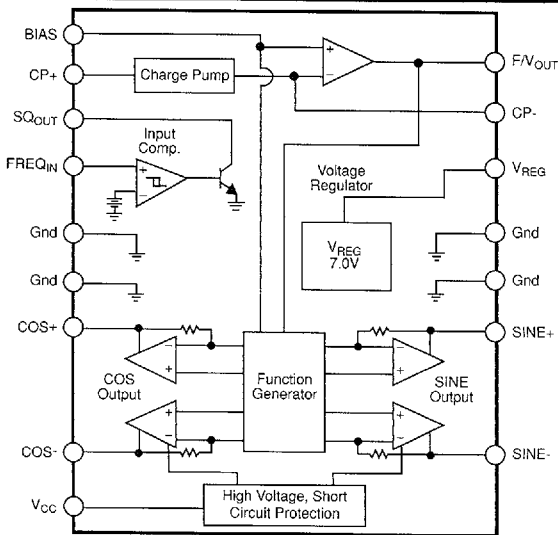

Features

- Direct Sensor Input
- High Output Torque
- Wide Output Voltage Range
- High Impedance Inputs
- Accurate down to 10V V_{CC}
- Fault Protection
 - Overvoltage
 - Short Circuit
- Low Voltage Operation

Package Options

16-Lead PDIP

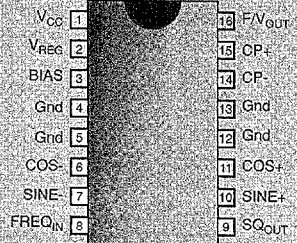

20-Lead SOIC (internally fused leads)

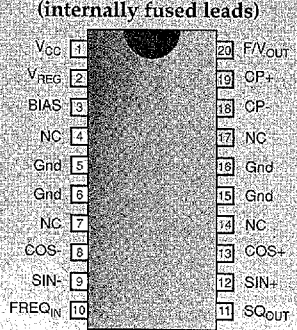

Cherry Semiconductor Corporation
 2000 South County Trail
 East Greenwich, Rhode Island 02818-1530
 Tel: (401)885-3600 Fax (401)885-5786
 email: info@cherry-semi.com

2067556 0003565 593

PARAMETER	TEST CONDITIONS	MIN	TYP	MAX	UNIT
■ Supply Voltage Section					
I _{CC} Supply Current	V _{CC} = 16V, -40°C, No Load		70	125	mA
V _{CC} Normal Operation Range		8.0	13.1	16.0	V
■ Input Comparator Section					
Positive Input Threshold		2.4	2.7	3.0	V
Negative Input Threshold		2.0	2.3		V
Input Hysteresis		200	400	1000	mV
Input Bias Current*	0V ≤ V _{IN} ≤ 8V		-2	±10	µA
Input Frequency Range		0		20	kHz
Input Voltage Range	in series with 1kΩ	-1		V _{CC}	V
Output V _{SAT}	I _{CC} = 10mA		0.15	0.40	V
Output Leakage	V _{CC} = 7V			10	µA
Logic 0 Input Voltage		2.0			V
*Note: Input is clamped by an internal 12V Zener.					
■ Voltage Regulator Section					
Output Voltage		6.50	7.00	7.50	V
Output Load Current				10	mA
Output Load Regulation	0 to 10 mA		10	50	mV
Output Line Regulation	8.0V ≤ V _{CC} ≤ 16V		20	150	mV
Power Supply Rejection	V _{CC} = 13.1V, 1V _{P/P} 1kHz	34	46		dB
■ Charge Pump Section					
Inverting Input Voltage		1.5	2.0	2.5	V
Input Bias Current			40	150	nA
V _{BIAS} Input Voltage		1.5	2.0	2.5	V
Non Invert. Input Voltage	I _{IN} = 1mA		0.7	1.1	V
Linearity*	@ 0, 87.5, 175, 262.5, +350Hz	-0.10	0.28	+0.70	%
F/V _{OUT} Gain	@ 350Hz, C _T = 0.0033µF, R _T = 243kΩ	7	10	13	mV/Hz
Norton Gain, Positive	I _{IN} = 15µA	0.9	1.0	1.1	I/I
Norton Gain, Negative	I _{IN} = -15µA	0.9	1.0	1.1	I/I
*Note: Applies to % of full scale (270°).					
■ Function Generator Section: -40° ≤ T_A ≤ 85°C, V_{CC} = 13.1V unless otherwise noted.					
Differential Drive Voltage (V _{COS+} - V _{COS-})	10V ≤ V _{CC} ≤ 16V Θ = 0°	7.5	8.0	8.5	V
Differential Drive Voltage (V _{SIN+} - V _{SIN-})	10V ≤ V _{CC} ≤ 16V Θ = 90°	7.5	8.0	8.5	V
Differential Drive Voltage (V _{COS+} - V _{COS-})	10V ≤ V _{CC} ≤ 16V Θ = 180°	-8.5	-8.0	-7.5	V
Differential Drive Voltage (V _{SIN+} - V _{SIN-})	10V ≤ V _{CC} ≤ 16V Θ = 270°	-8.5	-8.0	-7.5	V
Differential Drive Load	10V ≤ V _{CC} ≤ 16V, -40°C	178			Ω
	25°C	239			Ω
	105°C	314			Ω
Zero Hertz Output Voltage		-0.08	0.0	+0.08	V

Electrical Characteristics: continued

PARAMETER	TEST CONDITIONS	MIN	TYP	MAX	UNIT
Function Generator Section: continued					
Function Generator Error *	$\Theta = 0^\circ$ to 225°	-2	0	+2	deg
Reference Figures 1 - 4	$\Theta = 226^\circ$ to 305°	-3	0	+3	deg
Function Generator Error	$13.1V \leq V_{CC} \leq 16V$	-1	0	+1	deg
Function Generator Error	$13.1V \leq V_{CC} \leq 10V$	-1	0	+1	deg
Function Generator Error	$13.1V \leq V_{CC} \leq 8.0V$	-7	0	+7	deg
Function Generator Error	$25^\circ C \leq T_A \leq 80^\circ C$	-2	0	+2	deg
Function Generator Error	$25^\circ C \leq T_A \leq 105^\circ C$	-4	0	+4	deg
Function Generator Error	$-40^\circ C \leq T_A \leq 25^\circ C$	-2	0	+2	deg
Function Generator Gain	$T_A = 25^\circ C, \Theta$ vs F/V_{OUT}	60	77	95	$^\circ/V$

*Note: Deviation from nominal per Table 1 after calibration at 0° and 270° .

Package Lead Description

PACKAGE LEAD #		LEAD SYMBOL	FUNCTION
16L	20L		
1	1	V_{CC}	Ignition or battery supply voltage.
2	2	V_{REG}	Voltage regulator output.
3	3	BIAS	Test point or zero adjustment.
4, 5, 12, 13	5, 6, 15, 16	Gnd	Ground Connections.
6	8	COS-	Negative cosine output signal.
7	9	SIN-	Negative sine output signal.
8	10	FREQ _{IN}	Speed or rpm input signal.
9	11	SQ _{OUT}	Buffered square wave output signal.
10	12	SIN+	Positive sine output signal.
11	13	COS+	Positive cosine output signal.
14	18	CP-	Negative input to charge pump.
15	19	CP+	Positive input to charge pump.
16	20	F/V_{OUT}	Output voltage proportional to input signal frequency.
	4, 7, 14, 17	NC	No connection.

Typical Performance Characteristics

Figure 1: Function Generator Output Voltage vs Degrees of Deflection

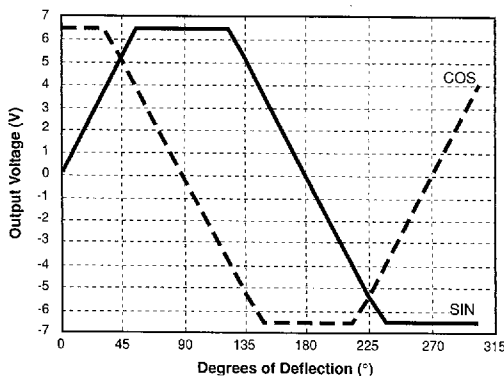

Figure 2: Charge Pump Output Voltage vs Output Angle

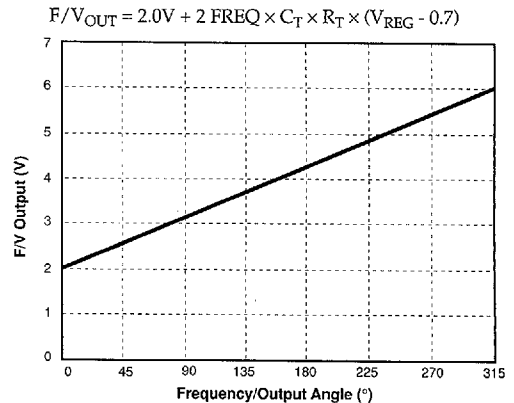

Figure 3: Output Angle in Polar Form

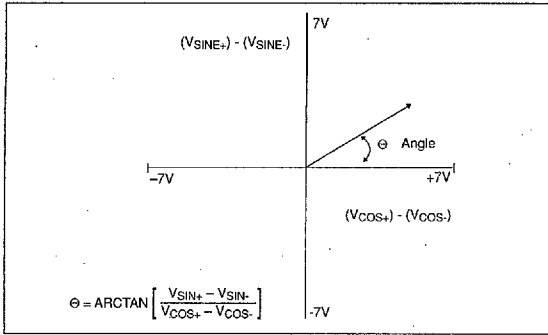
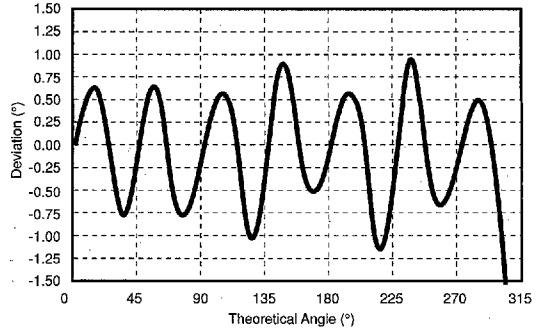

Figure 4: Nominal Output Deviation



Nominal Angle vs. Ideal Angle (After calibrating at 180°)

Note: Temperature, voltage and nonlinearity not included.

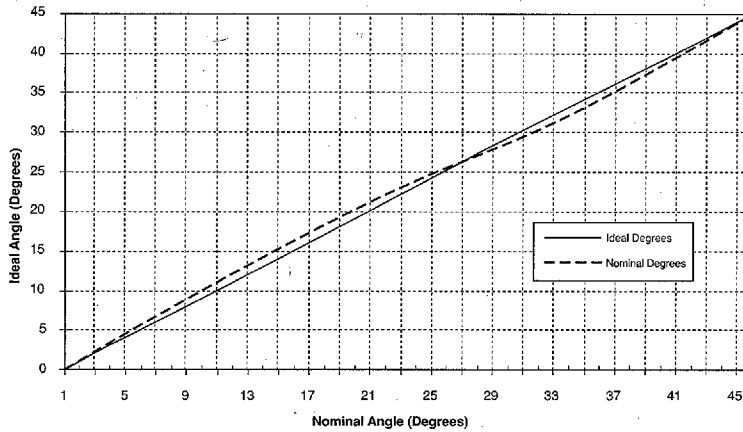

Table 1: Function Generator Output Nominal Angle vs. Ideal Angle (After calibrating at 270°)

Ideal θ Degrees	Nominal θ Degrees	Ideal θ Degrees	Nominal θ Degrees	Ideal θ Degrees	Nominal θ Degrees	Ideal θ Degrees	Nominal θ Degrees	Ideal θ Degrees	Nominal θ Degrees	Ideal θ Degrees	Nominal θ Degrees
0	0	17	17.98	34	33.04	75	74.00	160	159.14	245	244.63
1	1.09	18	18.96	35	34.00	80	79.16	165	164.00	250	249.14
2	2.19	19	19.92	36	35.00	85	84.53	170	169.16	255	254.00
3	3.29	20	20.86	37	36.04	90	90.00	175	174.33	260	259.16
4	4.38	21	21.79	38	37.11	95	95.47	180	180.00	265	264.53
5	5.47	22	22.71	39	38.21	100	100.84	185	185.47	270	270.00
6	6.56	23	23.61	40	39.32	105	106.00	190	190.84	275	275.47
7	7.64	24	24.50	41	40.45	110	110.86	195	196.00	280	280.84
8	8.72	25	25.37	42	41.59	115	115.37	200	200.86	285	286.00
9	9.78	26	26.23	43	42.73	120	119.56	205	205.37	290	290.86
10	10.84	27	27.07	44	43.88	125	124.00	210	209.56	295	295.37
11	11.90	28	27.79	45	45.00	130	129.32	215	214.00	300	299.21
12	12.94	29	28.73	50	50.68	135	135.00	220	219.32	305	303.02
13	13.97	30	29.56	55	56.00	140	140.68	225	225.00		
14	14.99	31	30.39	60	60.44	145	146.00	230	230.58		
15	16.00	32	31.24	65	64.63	150	150.44	235	236.00		
16	17.00	33	32.12	70	69.14	155	154.63	240	240.44		

Note: Temperature, voltage and nonlinearity not included.

The CS-8191 is specifically designed for use with air-core meter movements. It includes an input comparator for sensing an input signal from an ignition pulse or speed sensor, a charge pump for frequency to voltage conversion, a bandgap voltage regulator for stable operation, and a function generator with sine and cosine amplifiers to differentially drive the motor coils.

From the simplified block diagram of Figure 5A, the input signal is applied to the $FREQ_{IN}$ lead, this is the input to a high impedance comparator with a typical positive input threshold of 2.7V and typical hysteresis of 0.4V. The output of the comparator, SQ_{OUT} , is applied to the charge pump input $CP+$ through an external capacitor C_T . When the input signal changes state, C_T is charged or discharged through R3 and R4. The charge accumulated on C_T is mirrored to C4 by the Norton Amplifier circuit comprising of Q1, Q2 and Q3. The charge pump output voltage, F/V_{OUT} , ranges from 2V to 6.3V depending on the input signal frequency and the gain of the charge pump according to the formula:

$$F/V_{OUT} = 2.0V + 2 \times FREQ \times C_T \times R_T \times (V_{REG} - 0.7V)$$

R_T is a potentiometer used to adjust the gain of the F/V output stage and give the correct meter deflection. The F/V output voltage is applied to the function generator which generates the sine and cosine output voltages. The output voltage of the sine and cosine amplifiers are derived from the on-chip amplifier and function generator circuitry. The various trip points for the circuit (i.e., 0° , 90° , 180° , 270°) are determined by an internal resistor divider and the bandgap voltage reference. The coils are differentially driven, allowing bidirectional current flow in the outputs, thus providing up to 305° range of meter deflection. Driving the coils differentially offers faster response time, higher current capability, higher output voltage swings, and reduced external component count. The key advantage is a higher torque output for the pointer.

The output angle, Θ , is equal to the F/V gain multiplied by the function generator gain:

$$\Theta = A_{F/V} \times A_{FG}$$

where:

$$A_{FG} = 77^\circ/V \text{ (typ)}$$

The relationship between input frequency and output angle is:

$$\Theta = A_{FG} \times 2 \times FREQ \times C_T \times R_T \times (V_{REG} - 0.7V)$$

$$\text{or, } \Theta = 970 \times FREQ \times C_T \times R_T$$

The ripple voltage at the F/V converter's output is determined by the ratio of C_T and C_4 in the formula:

$$\Delta V = \frac{C_T(V_{REG} - 0.7V)}{C_4}$$

Ripple voltage on the F/V output causes pointer or needle flutter especially at low input frequencies.

The response time of the F/V is determined by the time constant formed by R_T and C_4 . Increasing the value of C_4 will reduce the ripple on the F/V output but will also increase the response time. An increase in response time causes a very slow meter movement and may be unacceptable for many applications.

Design Example

Maximum meter Deflection = 270°

Maximum Input Frequency = 350Hz

1. Select R_T and C_T

$$\Theta = A_{GEN} \times \Delta F/V$$

$$\Delta F/V = 2 \times FREQ \times C_T \times R_T \times (V_{REG} - 0.7V)$$

$$\Theta = 970 \times FREQ \times C_T \times R_T$$

Let $C_T = 0.0033\mu F$, Find R_T

$$R_T = \frac{270^\circ}{970 \times 350Hz \times 0.0033\mu F}$$

$$R_T = 243k\Omega$$

R_T should be a 250k Ω potentiometer to trim out any inaccuracies due to IC tolerances or meter movement pointer placement.

2. Select R3 and R4

Resistor R3 sets the output current from the voltage regulator. The maximum output current from the voltage regulator is 10mA, R3 must ensure that the current does not exceed this limit.

Choose R3 = 3.3k Ω

The charge current for C_T is:

$$\frac{V_{REG} - 0.7V}{3.3k\Omega} = 1.90mA$$

C_1 must charge and discharge fully during each cycle of the input signal. Time for one cycle at maximum frequency is 2.85ms. To ensure that C_T is discharged, assume that the $(R_3 + R_4) C_T$ time constant is less than 10% of the minimum input frequency pulse width.

$$T = 285\mu s$$

Choose R4 = 1k Ω .

Charge time: $T = R_3 \times C_T = 3.3k\Omega \times 0.0033\mu F = 10.9\mu s$

Discharge time: $T = (R_3 + R_4) C_T = 4.3k\Omega \times 0.0033\mu F = 14.2\mu s$

3. Determine C4

C_4 is selected to satisfy both the maximum allowable ripple voltage and response time of the meter movement.

$$C_4 = \frac{C_T(V_{REG} - 0.7V)}{V_{RIPPLE(MAX)}}$$

With $C_4 = 0.47\mu F$, the F/V ripple voltage is 44mV.

Figure 7 shows how the CS-8191 and the CS-8441 are used to produce a Speedometer and Odometer circuit.

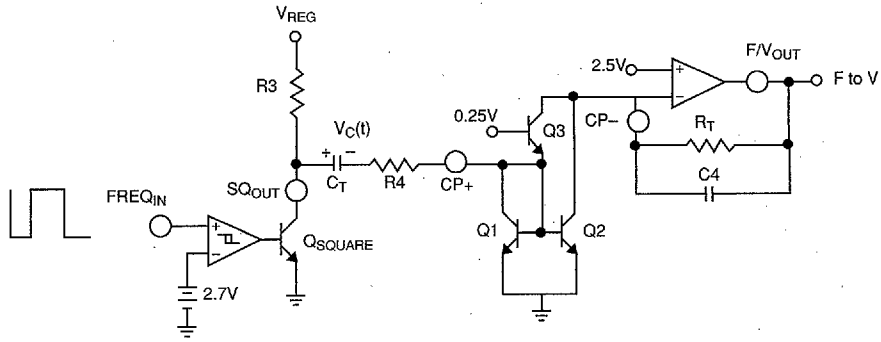
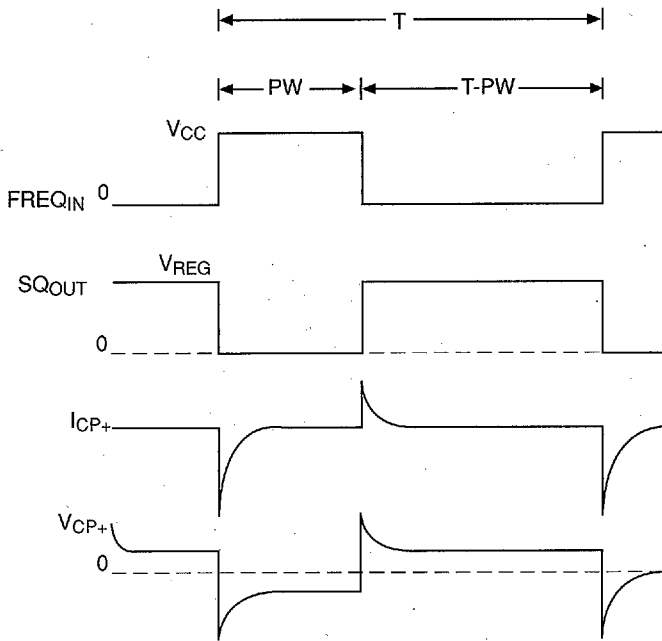

Figure 5A: Partial Schematic of Input and Charge Pump

Figure 5B: Timing Diagram of $FREQ_{IN}$ and I_{CP}

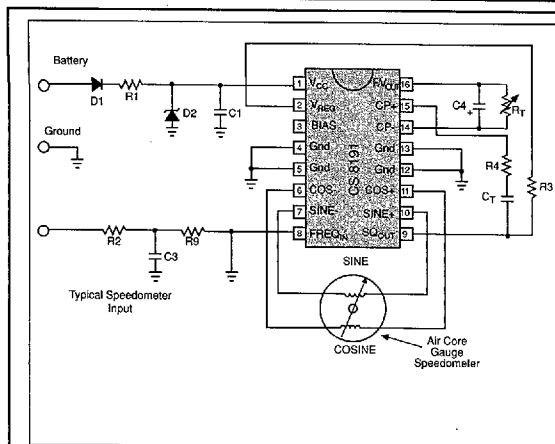

Figure 6

- R1 - 3.9, 500mW
- R2 - 10k Ω
- R3 - 3k Ω
- R4 - 1k Ω
- R_T - Trim Resistor +/- 20 PPM/DEG. C
- C1 - 0.1 μ F
- C2 - With CS-8441 application, 10 μ F
- C3 - 0.1 μ F
- C4 - 0.47 μ F
- C_T - 0.0033 μ F, +/- 30 PPM/ $^{\circ}$ C
- D1 - 1A, 600 PIV
- D2 - 50V, 500mW Zener

Note 1: The product of C4 and R4 have a direct effect on gain and therefore directly effect temperature compensation.

Note 2: C4 Range; 20pF to .2 μ F.

Note 3: R4 Range; 100k Ω to 500k Ω .

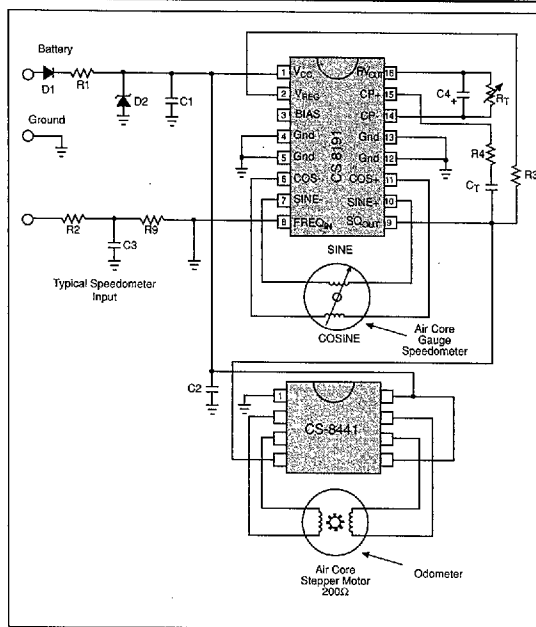

Figure 7

Note 4: The IC must be protected from transients above 60V and reverse battery conditions.

Note 5: Additional filtering on the FREQ_{IN} lead may be required.

In some cases a designer may wish to use the CS-8191 only as a driver for an air-core meter having performed the F/V conversion elsewhere in the circuit.

Figure 8 shows how to drive the CS-8191 with a DC voltage ranging from 2V to 6V. This is accomplished by forcing a voltage on the F/V_{OUT} lead. The alternative scheme shown in figure 9 uses an external op amp as a buffer and operates over an input voltage range of 0V to 4V.

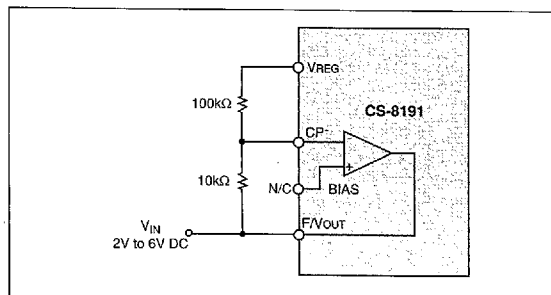

Figure 8. Driving the CS-8191 from an external DC voltage.

An alternative solution is to use the CS-4101 which has a separate function generator input lead and can be driven directly from a DC source.

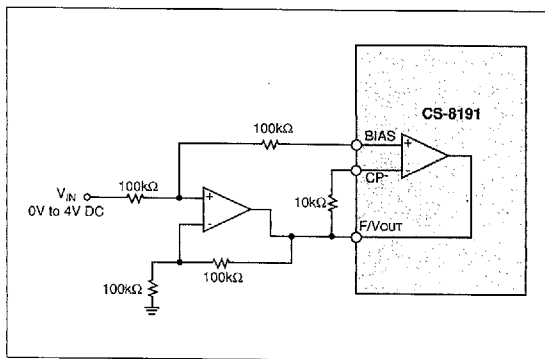

Figure 9. Driving the CS-8191 from an external DC voltage using an Op Amp Buffer.

Package Specification

PACKAGE DIMENSIONS IN mm (INCHES)

PACKAGE THERMAL DATA

Lead Count	D			
	Metric		English	
	Max	Min	Max	Min
16L PDIP	19.18	18.92	.755	.745
20L SOIC	12.95	12.70	.510	.500

Thermal Data		16L PDIP	20L SOIC	
		(internally fused leads)		
R _{θJC}	typ	15	9	°C/W
R _{θJA}	typ	50	55	°C/W

16 Lead PDIP

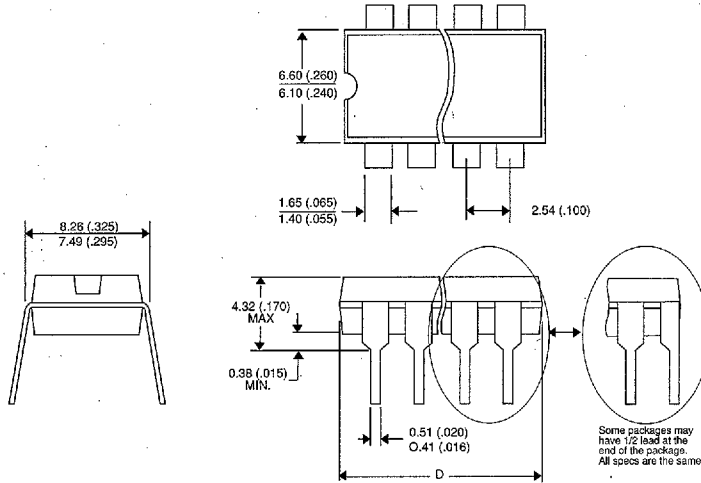

20 Lead SO Wide Batwing

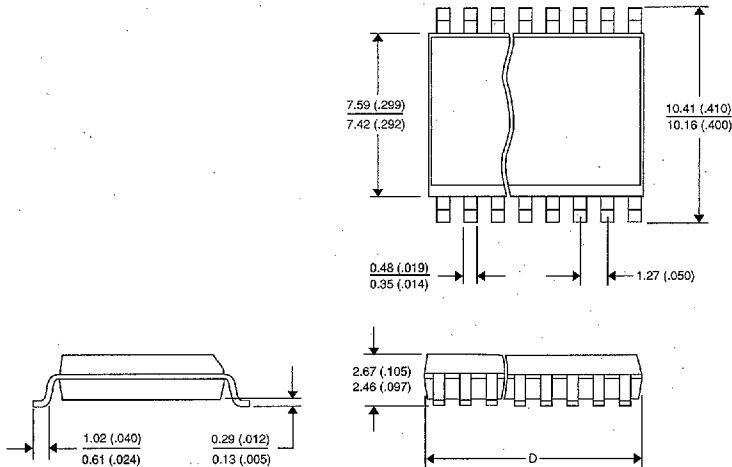

Ordering Information

Part Number	Description
CS-8191N16	16L PDIP
CS-8191DW20	20L SOIC (internally fused leads)
CS-8191DWR20	20L SOIC (internally fused leads) Tape and Reel

2067556 0003572 723