

# 3-Phase Bridge Driver IC

## Features

- Compatible to very low ohmic normal level input N-Channel Mosfets
- Separate input for each MOSFET
- PWM frequency up to 30kHz
- Fulfills specification down to 9V supply voltage
- Low EMC sensitivity and emission
- Separate Source connection for each MOSFET
- Adjustable dead time
- Adjustable di/dt limitation
- Short circuit protection with adjustable current limitation
- Driver undervoltage warning
- Reverse polarity protection
- Disable function
- Input with TTL characteristics
- Error flag
- Thermal overload warning for driver IC
- Shoot through protection
- Shoot through option
- Integrated bootstrap diodes

## Product Summary

Turn on current	$I_{Oxx(on)}$	0.9	A
Turn off current	$I_{Oxx(off)}$	0.85	A
Supply voltage range	$V_{Vs}$	8...20	V
Gate Voltage	$V_{GS}$	10	V
Temperature range	$T_J$	-40...+150	°C



Ordering Code  
**Q67007-A9406**

## Application

- Dedicated for 3-phase high current motor bridges in PWM control mode. This device fulfills requirements in 12V automotive applications

## General Description

3-phase bridge driver IC for MOSFET power stages with multiple protection functions.

## Block Diagram

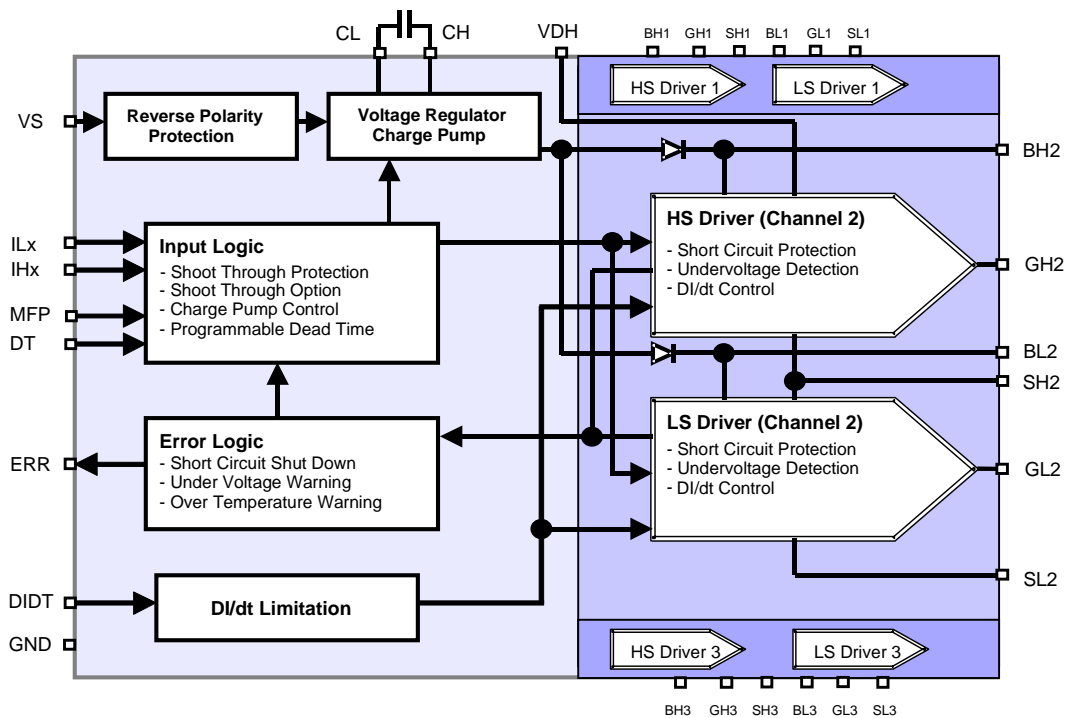

### Application Block Diagram

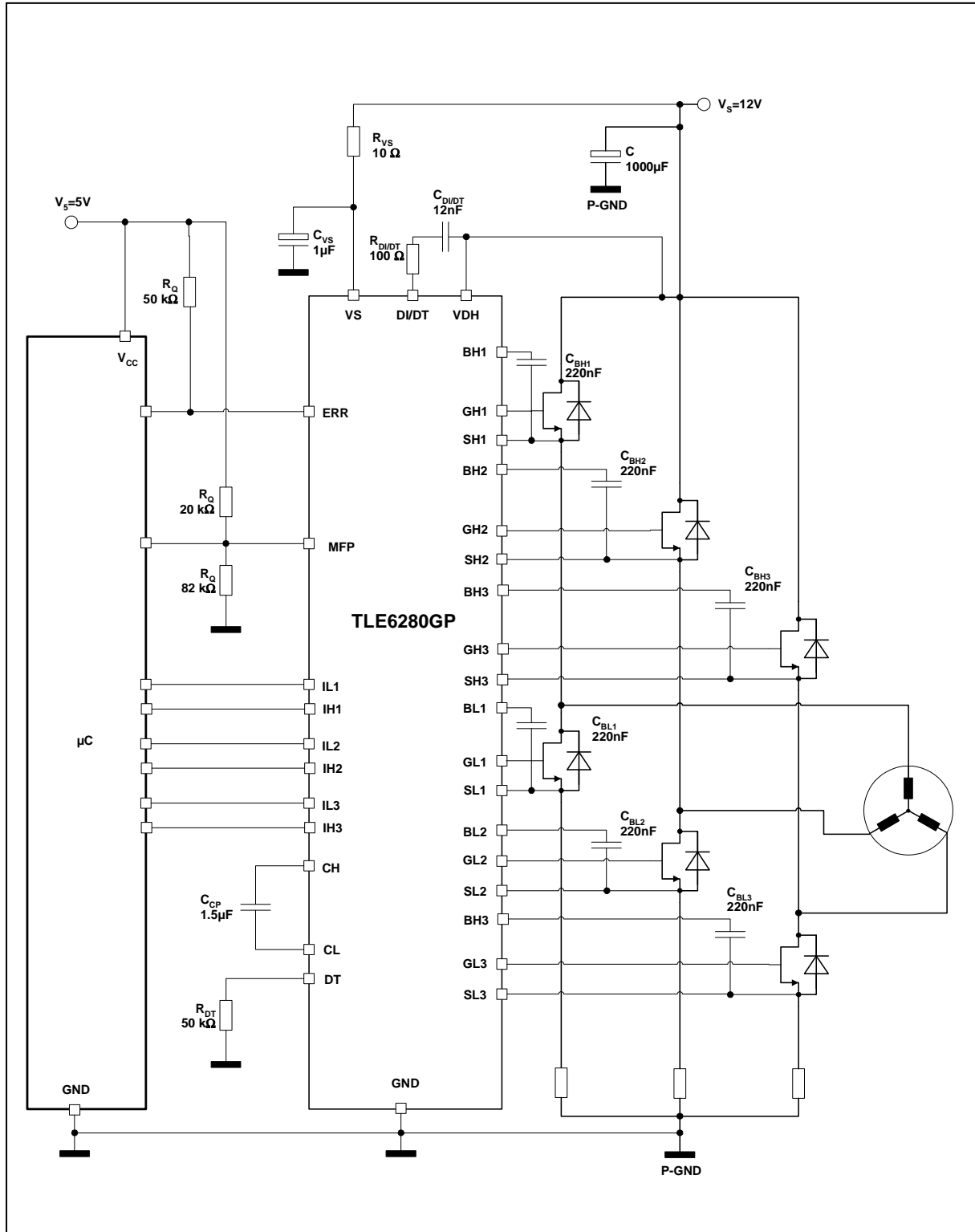

Fig. 1 : Application circuit

Remark: This application diagram is one possible implementation of this driver IC. There is, e.g., the possibility to link all three BLx pins and use only one capacitor.

Pin	Symbol	Function
1;18;19:36	GND	Logic Ground
8	VS	Voltage supply
20	CL	Charge pump - capacitor
21	CH	
9	IH1	Control inputs for high-side switches 1 to 3 (low active)
11	IH2	
13	IH3	
10	IL1	Control inputs for low-side switches 1 to 3 (high active)
12	IL2	
14	IL3	
15	MFP	Multi function pin: a) Disable the complete device by $V_{MFP} < 1V$ b) Program pin for output voltage level under short circuit condition ( $V_{Gxx} - V_{Sxx} = 2 \times V_{MFP}$ ) c) Enable shoot through option by $V_{MFP} > 4.5V$
17	DT	Program pin for dead time
35	DIDT	Program pin di/dt limitation
34	VDH	Sense pin for drain voltage of the high-side Mosfets
16	ERR	Error flag for driver supply under voltage, over-temperature and short circuit (open drain output)
2	BH1	Bootstrap supply high-side switches 1 to 3
28	BH2	
22	BH3	
5	BL1	Backup capacitor connection low switches 1 to 3
31	BL2	
25	BL3	
3	GH1	Output to gate high-side switches 1 to 3
29	GH2	
23	GH3	
6	GL1	Output to gate low-side switches 1 to 3
32	GL2	
26	GL3	
4	SH1	Connection to source high-side switches 1 to 3
30	SH2	
24	SH3	
7	SL1	Connection to source low-side switches 1 to 3
33	SL2	
27	SL3	

## Functional description

### General

In the automotive sector there are more and more applications requiring high performance motor drives, such as electro-hydraulic or electric power steering. In these applications 3-phase motors, synchronous and asynchronous, are used, combining high output performance, low space requirements and high reliability.

The TLE6280GP is a driver IC dedicated to control the 6 to 12 external Mosfets forming the converter for high current 3 phase motor drives in the automotive sector. It incorporates features like short circuit detection, diagnosis and high output performance and combines it with typical automotive specific requirements like full functionality even at low battery voltages. Its 3 high-side and 3 low-side output stages are powerful enough to drive Mosfets with 250nC gate charge with approx. 300ns fall and rise times.

Typical applications are cooling fan, water pump, electro-hydraulic and electric power steering. The TLE6280GP is designed for a 12V power net.

Use in 24V application is possible as well. Limiting factor could be the power dissipation.

This datasheet describes all functionality of this device. Additional application tips are given in an application note available on the Internet.

### Output stages

The 3 low-side and 3 high-side powerful push-pull output stages are all floating blocks, each with its own Source pin. This allows the direct connection of the output stage to the Source of each single Mosfet, allowing a perfect control of each Gate-Source voltage even when 200A are driven in the bridge with rise and fall times clearly below 1 $\mu$ s.

All 6 output stages have the same output power and, due to the use of the bootstrap principle, they can be switched all up to 30kHz.

Its output stages are powerful enough to drive Mosfets with 250nC gate charge with approx. 300ns fall and rise times, or even to run 12 such Mosfets with fall and rise times of approx. 600ns.

Maximum allowed power dissipation and the need to refresh the bootstrap capacitors with a minimum refresh pulse limit the device use for higher frequencies.

Fig. 2 shows the supply structure of TLE6280GP. The bootstrap capacitors are charged by the charge pump capacitor  $C_{CP}$  via the CH pin and diodes.

The exact value for this minimum refresh pulse is given by the RC time constant formed by the impedance between the CH pin and Bxx pin, and the capacitor formed by the external Mosfet ( $C_{Mosfet} = Q_{Gate-total} / V_{GS}$ ). The size of the bootstrap capacitor has to be adapted to the external Mosfet that the driver IC has to drive. Usually the bootstrap capacitor is about 10-20 times bigger than  $C_{Mosfet}$ . External components, such as R-C networks, at the Vs Pin have to be considered, too.

### Operation at Vs<12V – integrated charge pump

The TLE6280GP provides a feature tailored to the requirements of 12V automotive applications. Often the operation of an application has to be assured even at 9V-supply voltage or lower. Normally bridge driver ICs provide in such conditions clearly less than 9V to the Gate of the external Mosfet, increasing its RDSon and associated the power dissipation.

The supply structure of the device is shown in fig.2. The TLE 6280GP has a built-in voltage regulator with charge pump control to generate an internal supply voltage of 13V within a supply voltage range of 8-40V. Operation below 8V is possible as well and will result in a reduced Gate voltage. The charge pump works with an external capacitor  $C_{CP}$  connected between the CL and CH pins. It provides more than 13V at the CH pin and guarantees high supply voltage for the bootstrap capacitors  $C_{Bx}$ .

The Input Low-side pins ILx (see Fig. 3) trigger the charge pump. As soon as the first external low-side Mosfet is switched on and the corresponding bootstrap capacitor is connected to GND, the  $C_{CP}$  is pushed to high and provides about 13V at the CH pin.  $C_{CP}$  can now di-

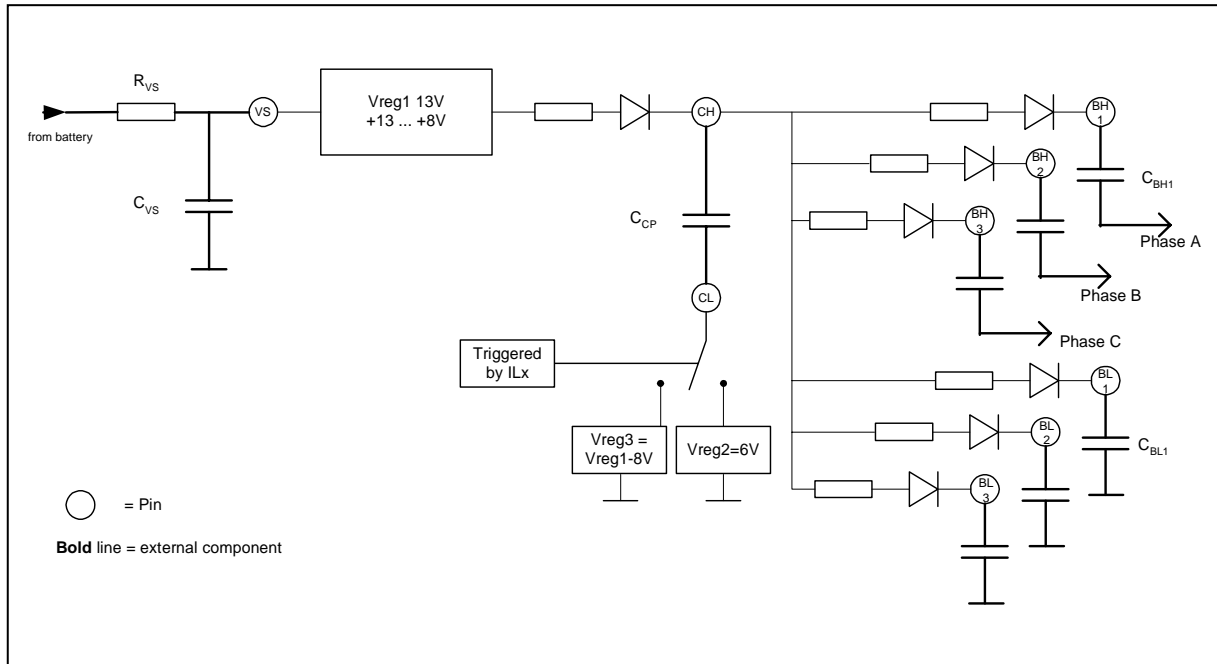

Fig. 2: Supply structure with external components (compare to Fig. 1)

rectly feed the low-side output stages and recharge the bootstrap capacitors connected to GND.

As soon as the first of the 3 external low-side Mosfets is switched off, the  $C_{CP}$  will be pulled down to be re-charged.

This synchronous operation with the output stages has the benefit that the electromagnetic emissions generated by the charge pump can be filtered by the same filter necessary to filter the EME of the converter itself. At the same time it is assured that the high voltage at the CH pin is available just in time to charge the high-side bootstrap.

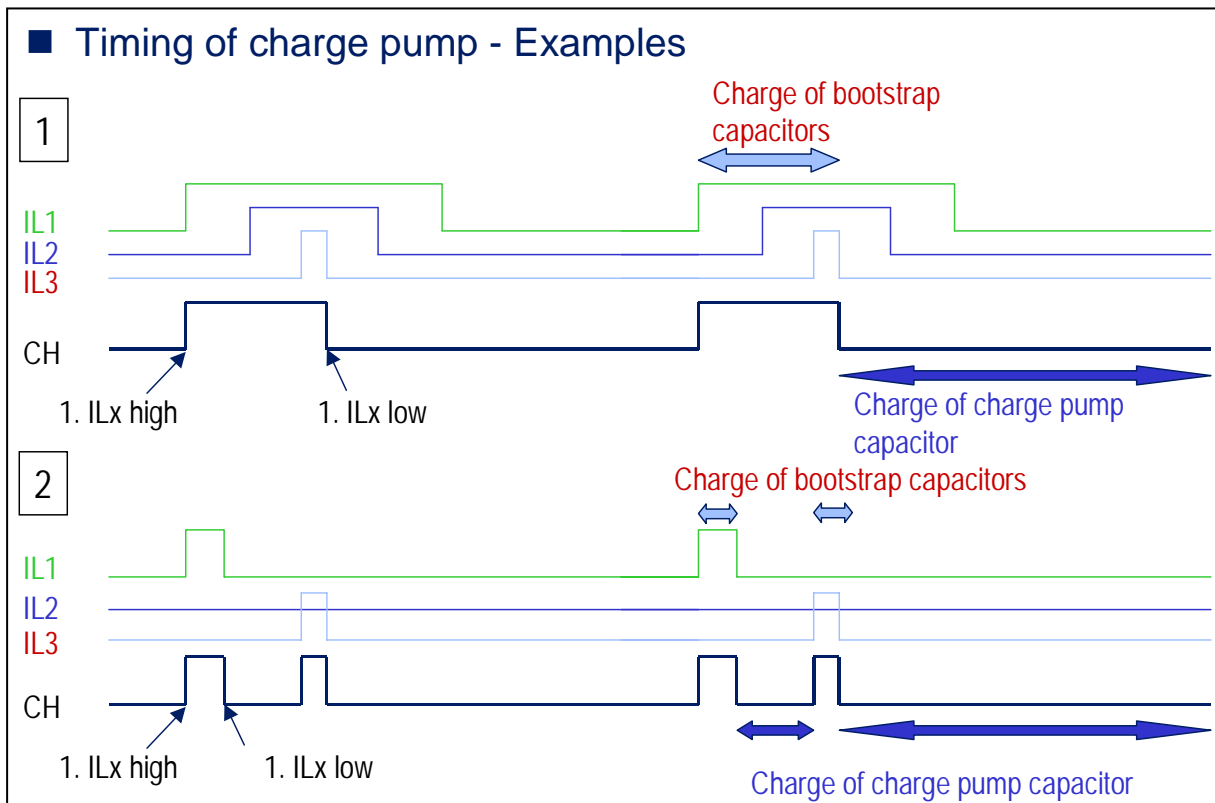

Fig. 3: Trigger timing of charge pump caused by changing input signals

The size of the  $C_{Bxx}$  and  $C_{CP}$  capacitors depends upon the gate charge of the Mosfet. (See “output stages”).  $C_{CP}$  is usually 6 times larger than  $C_{Bxx}$ .

**Dead Time and Shoot through option.**

In bridge applications it has to be assured that the external high-side and low-side Mosfets are not “on” at the same time, such that the battery voltage is directly connected to GND. This is usually assured by the integration of delays in a driver IC, generating a so-called dead time between switching off the external Mosfet and switching on the other Mosfet of the same half-bridge.

The dead times generated in the TLE6280GP are adjustable. The dead time generated by the TLE6280GP can be varied from 100ns to 4µs by connecting an external resistor from the DT pin to GND. The dead time has to be long enough to avoid a short between battery and GND, while the dead time should be as short as possible to reduce extra power dissipation in the external Mosfets.

In addition to this adjustable delay, the TLE6280GP provides a locking mechanism, preventing both external Mosfets of one half-bridge from being switched on at the same time. This functionality is called shoot through protection.

If the command to switch on both high and low-side switches in the same half-bridge is given at the input pins, the command will be ignored. (See dead time diagrams, fig. 6-8)

This shoot through protection can be deactivated by setting the MFP-pin to 5V.

**Short circuit protection / current limitation**

The TLE6280GP provides a short circuit protection for the external Mosfets, by monitoring the Drain-Source voltage of the external Mosfets. As soon as this voltage is higher than the short circuit detection limit, the Gate-Source voltage of this Mosfet will be limited to twice the voltage at the MFP-Pin, providing a current limitation.

The short circuit detection level is dependent upon the voltage of the MFP pin as well (see diagrams).

After a delay of about 11µs all external Mosfets will be switched off until the driver is reset by the MFP pin. The error flag is set.

The Drain-Source voltage monitoring of the short circuit detection for certain external Mosfets is active as soon as the corresponding input is set to “on” and the dead time is expired. This feature provides a 2-step switch-on behavior for each regular switching-on of a Mosfet.

**Description of MFP pin (Multi functional pin)**

The MFP pin has multiple tasks:

- 1) Reset the device.
- 2) Adjust the short circuit detection level of the external Mosfet and define the gate voltage limitation for current limitation in case of short circuit
- 3) Deactivate the shoot-through protection

Fig 4. shows the internal structure of the MFP pin.

Condition of MFP pin	Function
0 – 1.1V	Disable the driver. All external Mosfets will be actively switched off
2.5 – 4.0 V	Adjustable short circuit detection level combined with adjustable gate voltage limitation for current limitation. Shoot-through protection is active.
> 4.5V	Shoot-through protection deactivated.

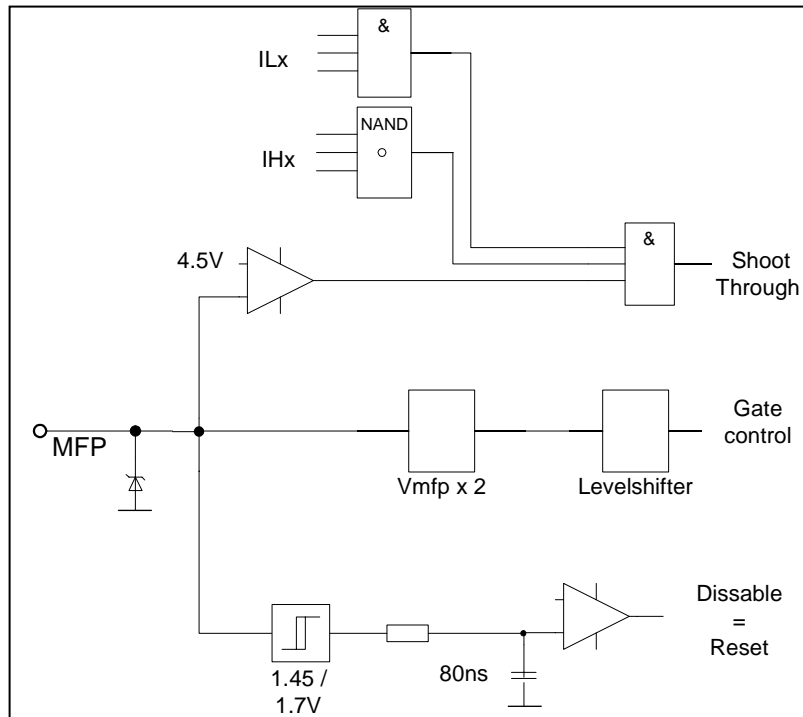

Fig. 4: Block diagram of internal structure of MFP pin

### Shoot through protection / option

As already mentioned, the device has a built-in shoot-through protection, to avoid a simultaneous activation of high- and low-side switch in one half-bridge.

In case there is a short circuit in the bridge, the driver will switch off all external Mosfets. If there is still current flowing in the motor, it is possible for the user to override this shoot through protection.

By setting the ILx to “high”, the IHx to “low” and MFP to a level above 4.5V, all external Mosfets will be turned on simultaneously to blow a well-dimensioned fuse. The application will be finally disconnected in this way from battery, and thus guarantee that the motor does not apply any uncontrolled torque.

### Undervoltage warning:

If the voltage of a bootstrap capacitor  $C_{Bxx}$  reaches the undervoltage warning level the error flag is set and will remain set until the voltage of the bootstrap capacitor has recovered. The error signal can be seen as a warning that an undervoltage shut-down could occur soon, and the user can take appropriate measures to avoid this. Such measures could be the change of the duty cycle to a range of 10-90% or the ramp down of the motor.

### Undervoltage shut down:

The TLE6280GP has an integrated undervoltage shut-down, to guarantee that the behavior of the device is predictable in all voltage ranges.

If the voltage of a bootstrap capacitor  $C_{Bxx}$  reaches the undervoltage shut-down level, the Gate-Source voltage of the affected external Mosfet will be actively pulled to low. In this situation the short circuit detection of this output stage is deactivated to avoid a complete shut down of the driver. This allows continued operation of the motor in case of undervoltage shut-down for a short period of time.

As soon as the bootstrap voltage recovers, the output stage condition will be aligned to the input patterns by the next changing input signal at the corresponding input pin.

### Diagnosis

The ERR pin is an open collector output and has to be pulled up with external pull-up resistors to 5V. In normal conditions the ERR signal is high. In case of an error the ERR pin is pulled down. There are 3 different causes for an error signal:

- 1) Short circuit of an external Mosfet – all external Mosfets are switched off. The driver has to be reset to start again.
- 2) Undervoltage warning: at least one of the external capacitors connected to Bxx pins has a voltage below the warning level.
- 3) Over-temperature warning: The device works normally but is out of the maximum ratings. Immediate actions have to be taken to reduce the thermal load. The error flag will be removed when the driver reached temperatures below the over temperature warning level.

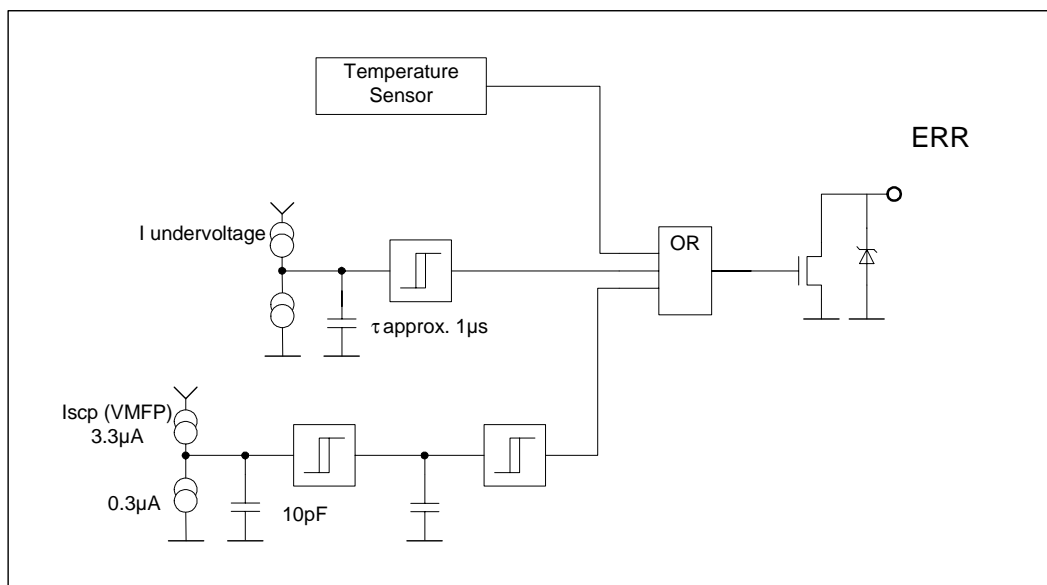

Fig. 5: Block diagram of ERR functionality

### di/dt control

In all high current PWM applications, transient overvoltages and electro-magnetic emissions are critical items. The di/dt regulation of the TLE6280GP helps to reduce transient overvoltage as well as electro-magnetic emissions.

Each real bridge configuration has stray inductance in each half-bridge. When the Mosfets in the bridge are switching and load current is flowing, the stray inductance together with the di/dt in the halfbridge causes transient overvoltages. These transient overvoltages can be feed to the DIDD pin of the gate driver by a high pass filter. Voltages exceeding 2 to 5V or –2 to –5V at this pin will strongly reduce the gate current of the actually switched Mosfet, resulting in an increased switching time in the Miller plateau of the Mosfet, and reducing the switching speed exactly and only in the critical area of the switching process. Through this regulation over-voltages are reduced and a smoother di/dt in the bridge is obtained.

For more detailed information please refer to application note.

### Estimation of power dissipation within the driver IC



The power dissipation within the driver IC is strongly dependent upon the use of the driver and the external components. Nevertheless, a rough estimation of the worst case power dissipation is possible.

Worst case calculation is:

$$P_D = (Q_{gate} * n * const * f_{PWM} + I_{VS(open)}) * V_{Vs} - P_{RGate}$$

With:

$P_D$  = Power dissipation in the driver IC

$f_{PWM}$  = Switching frequency

$Q_{gate}$  = Total gate charge of used MOSFET at 10V  $V_{GS}$

$n$  = number of switched Mosfets

$const$  = constant considering some leakage current in the driver and the power dissipation caused by the charge pump (nominally = 2)

$I_{VS(open)}$  = Current consumption of driver without connected Mosfets during switching

$V_{Vs}$  = Voltage at  $V_s$

$P_{RGate}$  = Power dissipation in the external gate resistors

This value can be reduced dramatically by the use of external gate resistors.

### Recommended start up procedure

To assure the driver to be active and functional, a special initialization procedure is required whenever the gate drive is enabled ( $V_{MFP}$  is changed from LO to HI). Every time the driver is enabled, after 10 $\mu$ s or later, positive-going transition signals at all ILx pins are required in order to ensure proper start-up of the output driver. This procedure assures a proper wake up the device and allows to fill the bootstrap capacitors. Not filling the bootstrap capacitors might lead to low Gate-Source voltages mainly in highside and can cause a short circuit detection when the highside switches are activated. Not changing the ILx input signal after enabling the device may cause the lowside outputs to stay in off conditions.

## Maximum ratings

Parameter and Conditions at $T_j = -40 \dots +150 \text{ }^\circ\text{C}$ , unless otherwise specified	Symbol	Values	Unit
Supply voltage <sup>1</sup>	$V_S$	-4 ... 45V	V
Operating temperature range	$T_j$	-40 ...+150	$^\circ\text{C}$
Storage temperature range	$T_{stg}$	-55 ...+150	
Max. voltage range at Ixx, MFP, DT; ERR		-0.3 ...+7	V
Max. voltage range at SLx <sup>2</sup>	$V_{SLx}$	-7 ...+7	V
Max. voltage range at SHx <sup>3</sup>	$V_{SHx}$	-7 ...+45	V
Max. voltage range at GLx <sup>2</sup>	$V_{GLx}$	-7 ...+18	V
Max. voltage range at GHx <sup>3</sup>	$V_{GHx}$	-7 ...+55	V
Max. voltage range at BHx <sup>3</sup>	$V_{BHx}$	-0.3 ...+55	V
Max. voltage range at VDH <sup>4</sup>	$V_{VDH}$	-4 ...+55	V
Max. voltage difference Bxx - Sxx	$V_{Bxx} - V_{Sxx}$	-0.3 ...+15	V
Max. voltage difference Gxx - Sxx	$V_{Gxx} - V_{Sxx}$	-0.3...+11	V
Max. voltage range at CL	$V_{CL}$	-0.3 ...+10	V
Max. voltage range at CH	$V_{CH}$	-0.3 ...+18	V
Max. voltage range at DIDT	$V_{DIDT}$	-7 ...+7	V
Power dissipation (DC) @ $T_C=125^\circ\text{C}$	$P_{tot}$	1.2	W
ESD voltage (Human Body Model) JESD22-A114-B	$V_{ESD}$		kV
@ all pins		1	
@ all pins excluding Gxx		2	
DIN humidity category, DIN 40 040		E	
IEC climatic category, DIN IEC 68-1		40/150/56	
Jedec Level		3	
Thermal resistance	junction-case	$R_{thJC}$	$\leq 5$ K/W

<sup>1</sup> With external resistor ( $\geq 10 \Omega$ ) and capacitor – see fig.1

<sup>2</sup> The min value -7V is reduced to  $-(V_S - 0.5V)$  if  $V_S < 7.5V$

<sup>3</sup> The min value -7V is reduced to  $-(V_{BHx} - V_{SHx} - 1V)$  if bootstrap voltages  $< 8V$

<sup>4</sup> The min value -4V is increased to  $-(V_{BHx} - V_{SHx})$  if bootstrap voltages  $< 4V$

## Functional range

Parameter and Conditions at $T_j = -40 \dots +150 \text{ }^\circ\text{C}$ , unless otherwise specified	Symbol	Values	Unit
Supply voltage <sup>5,6,7</sup>	$V_S$	8 ... 20	V
Operating temperature range	$T_j$	-40 ...+150	$^\circ\text{C}$
Duty Cycle @ 20kHz <sup>6,7,8</sup> $V_S > 8\text{V}$	$dc$	0...95	%
Max. voltage range at Ixx, ERR	$V_{Ixx}; V_{ERR}$	-0.3 ...+7	V
Max. voltage range at MFP, DT <sup>9</sup>	$V_{MFP}$	-0.3 ...+5	V
Max. voltage range at SLx <sup>2</sup>	$V_{SLx}$	-7 ...+7	V
Max. voltage range at SHx <sup>3</sup>	$V_{SHx}$	-7 ...+45	V
Max. voltage range at GLx <sup>2</sup>	$V_{GLx}$	-7 ...+18	V
Max. voltage range at GHx <sup>3</sup>	$V_{GHx}$	-7 ...+55	V
Max. voltage range at BHx <sup>3</sup>	$V_{BHx}$	-0.3 ...+55	V
Max. voltage range at VDH <sup>4</sup>	$V_{VDH}$	-4 ...+55	V
Max. voltage difference Bxx - Sxx	$V_{Bxx} - V_{Sxx}$	-0.3 ...+15	V
Max. voltage difference Gxx - Sxx	$V_{Gxx} - V_{Sxx}$	-0.3...+11	V
Max. voltage range at DIDT	$V_{DIDT}$	-7 ...+7	V
PWM frequency <sup>10</sup>	$f_{PWM}$	2...50	kHz
Min. dead time resistor	$R_{DT}$	0	k $\Omega$

<sup>5</sup> operation above 20V limited by max allowed power dissipation and max. ratings

<sup>6</sup> If all 3 half-bridges are switched with  $f_{PWM}$  and a duty cycle <10%, undervoltage shut down can occur below  $V_S=9.5\text{V}$

<sup>7</sup> Total gate charge of the attached Mosfet < 250nC

<sup>8</sup> If the bootstrap capacitor is charged to  $V_{BHx} - V_{SHx} = 12\text{V}$ , the maximum duty cycle is 100% for 500  $\mu\text{s}$

<sup>9</sup>  $V_{MFP}$  up to 7V allowed up to 500ms

<sup>10</sup> Limited only by the minimum bootstrap voltage (undervoltage logout of output stage) and the max allowed power dissipation

## Electrical Characteristics

Parameter and Conditions at $T_j = -40 \dots +150 \text{ }^\circ\text{C}$ , unless otherwise specified and supply voltage range $V_S = 8 \dots 20\text{V}$ ; $f_{\text{PWM}} = 20\text{kHz}$	Symbol	Values			Unit
		min	typ	max	

### Static Characteristics

Low level output voltage ( $V_{\text{Gxx}}-V_{\text{Sxx}}$ ) @ $I=10\text{mA}$	$\Delta V_{\text{LL}}$	--	50	100	mV
High level output voltage ( $V_{\text{Gxx}}-V_{\text{Sxx}}$ ) <sup>7</sup> @ $I=-10\text{mA}$	$\Delta V_{\text{HL}}$	8	10	11	V
Supply current at $V_S$ (device disabled) @ $V_{\text{bat}}=V_S=14\text{V}$ $R_{\text{DT}}=400\text{k}\Omega$ $V_{\text{MFP}}=0\text{V}$	$I_{\text{S(dis)}}$	--	--	12	mA
Supply current at $V_S$ @ $20\text{kHz}$ $V_{\text{MFP}}\leq 4\text{V}$ (Outputs open)	$I_{\text{S(open)}}$	--	19	28	mA
Low level input voltage	$V_{\text{IN(LL)}}$	--	--	1.0	V
High level input voltage	$V_{\text{IN(HL)}}$	2.0	--	--	V
Input hysteresis	$\Delta V_{\text{IN}}$		200		mV

### Dynamic characteristics

Turn on current @ $V_{\text{Gxx}}-V_{\text{Sxx}} = 0\text{V}$ ; $T_j=25^\circ\text{C}$ @ $V_{\text{Gxx}}-V_{\text{Sxx}} = 4\text{V}$ ; $T_j=125^\circ\text{C}$	$I_{\text{Gxx(on)}}$	--	0.93 0.95	--	A
Turn off current @ $V_{\text{Gxx}}-V_{\text{Sxx}} = 10\text{V}$ ; $T_j=25^\circ\text{C}$ @ $V_{\text{Gxx}}-V_{\text{Sxx}} = 4\text{V}$ ; $T_j=125^\circ\text{C}$	$I_{\text{Oxx(off)}}$	--	0.85 0.55	--	A
Dead time (adjustable) @ $R_{\text{DT}} = 10 \text{ k}\Omega$ @ $R_{\text{DT}} = 50 \text{ k}\Omega$ @ $R_{\text{DT}} = 200 \text{ k}\Omega$ @ $R_{\text{DT}} = 400 \text{ k}\Omega$ @ $R_{\text{DT}} > 1 \text{ M}\Omega$	$t_{\text{DT}}$	0.16	0.25 1.2 3.9 4.1 2.2	0.35	$\mu\text{s}$
Dead time @ $R_{\text{DT}} = 0 \text{ k}\Omega$ @ $T_j = -40^\circ\text{C}$ @ $T_j = +25^\circ\text{C}$ @ $T_j = +150^\circ\text{C}$	$t_{\text{DT}}$	20 25 45	55 70 110	125 130 200	ns
Rise time @ $C_{\text{Load}}=22\text{nF}$ ; $R_{\text{Load}}=1\Omega$ ; 20...80% $V_{\text{CLoad}}$ @ $T_j = -40^\circ\text{C}$ @ $T_j = +25^\circ\text{C}$ @ $T_j = +150^\circ\text{C}$	$t_{\text{rise}}$	--	310 250 170	700 600 600	ns
Fall time @ $C_{\text{Load}}=22\text{nF}$ ; $R_{\text{Load}}=1\Omega$ ; 20...80% $V_{\text{CLoad}}$ @ $T_j = -40^\circ\text{C}$ @ $T_j = +25^\circ\text{C}$ @ $T_j = +150^\circ\text{C}$	$t_{\text{fall}}$	--	220 250 200	400 350 350	ns

**Electrical Characteristics** (continued)

Parameter and Conditions at $T_J = -40 \dots +150 \text{ }^\circ\text{C}$ , unless otherwise specified and supply voltage range $V_S = 8 \dots 20\text{V}$ ; $f_{\text{PWM}} = 20\text{kHz}$	Symbol	Values			Unit
		min	typ	max	

**Dynamic characteristics** (continued)

Disable propagation time	$t_{\text{P(DIS)}}$	--	350	700	ns
Wake up time after enabling the device	$t_{\text{WU}}$			10	$\mu\text{s}$
Input propagation time (low on)	$t_{\text{P(ILN)}}$	--	220	500	ns
Input propagation time (low off)	$t_{\text{P(ILF)}}$	--	180	500	ns
Input propagation time (high on)	$t_{\text{P(IHN)}}$	--	250	500	ns
Input propagation time (high off)	$t_{\text{P(IHF)}}$	--	185	500	ns
Input propagation time difference (all channels turn on)	$t_{\text{PD(an)}}$	20	55	70	ns
Input propagation time difference (all channels turn off)	$t_{\text{PD(af)}}$	--	11	50	ns
Input propagation time difference (one channel; high off – low on)	$t_{\text{PD(1hfhn)}}$	--	60	150	ns
Input propagation time difference (one channel; low off – high on)	$t_{\text{PD(1lfhn)}}$	--	80	150	ns
Input propagation time difference (all channels; high off – low on)	$t_{\text{PD(ahfhn)}}$	--	60	150	ns
Input propagation time difference (all channels; low off – high on)	$t_{\text{PD(alafh)}}$	--	80	150	ns
DC-Resistance between CH and Bxx pin $I_{\text{CH-Bxx}} = 50\text{mA}$ ; $V_{\text{VS}} = V_{\text{Bxx}} = \text{GND} = 0\text{V}$ @ $T_J = -40^\circ\text{C}$ @ $T_J = +25^\circ\text{C}$ @ $T_J = +150^\circ\text{C}$	$R_{\text{CH-Bxx}}$	--			$\Omega$
Bootstrap diode forward voltage $I_{\text{CH-Bxx}} = 50\text{mA}$ @ $T_J = -40^\circ\text{C}$ @ $T_J = +25^\circ\text{C}$ @ $T_J = +150^\circ\text{C}$	$V_{\text{BSD}}$	--			V
			3.3	6.3	
			4.2	7.3	
			6.0	8.3	
			0.84	1.2	
			0.73	1.0	
			0.52	0.76	

**Electrical Characteristics** (continued)

Parameter and Conditions at $T_J = -40 \dots +150 \text{ }^\circ\text{C}$ , unless otherwise specified and supply voltage range $V_S = 8 \dots 20\text{V}$ ; $f_{\text{PWM}} = 20\text{kHz}$ ; $V_{\text{Bxx}} > 7.5\text{V}$	Symbol	Values			Unit
		min	typ	max	

**Diagnosis and Protection Functions**

Undervoltage warning at ERR @ $T_J = -40^\circ\text{C}$ @ $T_J = +25^\circ\text{C}$ @ $T_J = +150^\circ\text{C}$	$V_{\text{Bxx}} - V_{\text{Sxx}}$	8 8 8	9.4 9.3 9.0	10 10 10	V
Undervoltage shut down of output stage @ $T_J = -40^\circ\text{C}$ @ $T_J = +25^\circ\text{C}$ @ $T_J = +150^\circ\text{C}$	$V_{\text{Bxx}} - V_{\text{Sxx}}$	5.5 5.0 4.0	7.2 6.6 5.6	7.5 7.2 7.2	V
Over-temperature warning <sup>11</sup>	$T_{\text{J(OV)}}$	150	170	190	$^\circ\text{C}$
Hysteresis for over-temperature warning	$\Delta T_{\text{J(OV)}}$		20		$^\circ\text{C}$
Short circuit protection shut down time delay	$t_{\text{SCP(off)}}$	7	11	15	$\mu\text{s}$
Short circuit criteria ( $V_{\text{DS}}$ of Mosfets) @ $V_{\text{MFP}} = 3\text{V}$ <sup>12</sup> @ $T_J = -40^\circ\text{C}$ @ $T_J = +25^\circ\text{C}$ @ $T_J = +150^\circ\text{C}$	$V_{\text{DS(SCP)}}$	1.4 -- --	1.85 1.90 1.95	-- -- 2.3	V
Factor between $V_{\text{MFP}}$ and max. $V_{\text{GXX}}$ @ $2\text{V} < V_{\text{MFP}} < 4\text{V}$	$V_{\text{GxxMax}} / V_{\text{MFP}}$	1.67	2	2.27	
Disable input level	$V_{\text{MFP(DIS)}}$	--	--	1.1	V
Enable input level <sup>13</sup>	$V_{\text{MFP(EN)}}$	2.5	--	--	V
Disable input hysteresis	$\Delta V_{\text{MFP(DIS)}}$	--	500	--	mV
Error level @ $1.6\text{mA } I_{\text{ERR}}$	$V_{\text{ERR}}$	--	--	1.0	V

**Shoot through option**

Shoot through protection activated	$V_{\text{MFP}}$			4	V
Shoot through option activated	$V_{\text{MFP}}$	4.5	--	--	V

<sup>11</sup> specified by design

<sup>12</sup> Periodic short circuit condition will be detected within several cycles, if the duty cycle is more than 10%

<sup>13</sup> If the device is enabled, the slope of  $dU_{(V_{\text{MFP}})}/dt$  has to be higher than  $3.5\text{V}/50\mu\text{s}$

**Electrical Characteristics** (continued)

Parameter and Conditions at $T_J = -40 \dots +150 \text{ }^\circ\text{C}$ , unless otherwise specified and supply voltage range $V_S = 8 \dots 20\text{V}$ ; $f_{\text{PWM}} = 20\text{kHz}$ ; $V_{\text{Bxx}} > 7.5\text{V}$	Symbol	Values			Unit
		min	typ	max	

**di/dt limitation**

Non reaction level for di/dt limitation (100% gate driver capability) @ $V_{\text{DIDT}} > 0\text{V}$	$V_{\text{DIDT}}$	2	--	--	V
Non reaction level for di/dt limitation (100% gate driver capability) @ $V_{\text{DIDT}} < 0\text{V}$	$V_{\text{DIDT}}$	--	--	-2	V
Max. $V_{\text{Gxx}}$ at full reaction level for di/dt limitation @ $V_{\text{DIDT}} = -5\text{V}$ @ $T_J = -40^\circ\text{C}$ @ $T_J = +25^\circ\text{C}$ @ $T_J = +150^\circ\text{C}$	$V_{\text{Gxx(DIDT)}}$	--	1.9 2.3 3.4	3.0 3.0 4.2	V
Min. falltime at full reaction level for di/dt limitation @ $V_{\text{DIDT}} = +5\text{V}$ @ $T_J = -40^\circ\text{C}$ @ $T_J = +25^\circ\text{C}$ @ $T_J = +150^\circ\text{C}$	$t_{\text{fall (DIDT)}}$	20 20 20	65 68 70	-- -- --	$\mu\text{s}$
Impedance of DIDT Pin to GND $10\text{kHz} < f < 10\text{MHz}$ ; $V_{\text{DIDT}} = 5\text{V}$	$Z_{\text{DIDT}}$		60		$\Omega$

**Default status of input pins:**

To assure a defined status of all input pins in case of disconnection, these pins are internally secured by pull-up or pull-down current sources with approx.  $10\mu\text{A}$ . The following table shows the default status of each input pin.

Input pin	Default status
ILx	Low (ext. Mosfet off)
IHx	High (ext. Mosfet off)
DIDT	Low (no di/dt limitation)
DT	$2\mu\text{s}$ dead time
MFP	Disable (pull-down)

**Truth Table**

Input				Conditions			Output		
ILx	IHx	DT	MFP	UV	OT	SC	GLx	GHx	ERR
1	1	D	>2.5V	0	0	0	1	0	5V
0	0	D	>2.5V	0	0	0	0	1	5V
1	0	D	2.5-4.0V	0	0	0	A	A	5V
0	1	D	>2.5V	0	0	0	0	0	5V
0	0	D	>2.5V	1	0	0	0	1	0V
1	1	D	>2.5V	1	0	0	1	0	0V
1	0	D	2.5-4.0V	1	0	0	A	A	0V
0	1	D	>2.5V	1	0	0	0	0	0V
0	0	D	>2.5V	0	1	0	0	1	0V
1	1	D	>2.5V	0	1	0	1	0	0V
1	0	D	2.5-4.0V	0	1	0	A	A	0V
0	1	D	>2.5V	0	1	0	0	0	0V
X	X	D	>2.5V	0	0	1	0	0	B
X	X	D	<1.1V	0	0	X	0	0	5V
X	X	D	<1.1V	1	0	X	0	0	0V
X	X	D	<1.1V	0	1	X	0	0	0V
X	X	D	<1.1V	1	1	X	0	0	0V
C	C	D	>4.5V	X	X	X	1	1	0V

- A) stays in the output condition prior to the shoot through input command (see also dead time diagrams)
- B) ERR=0V and stays latched until reset
- C) All 3 ILx=1 AND all 3 IHx=0 (shoot through command)
- D) No influence on static results
- X) Can be 0 or 1

Remark:

If  $1.1V < VMFP < 2.5V$  the device is either working normally or is disabled.

If  $4.0V < VMFP < 4.5V$  the device is either working normally or will allow shoot through.

**Definition:**

In this datasheet a duty cycle of 98% means that the GLx pin is 2% of the PWM period in high condition.

Remark: Please consider the influence of the dead time for your input duty cycle



Dead time diagrams:

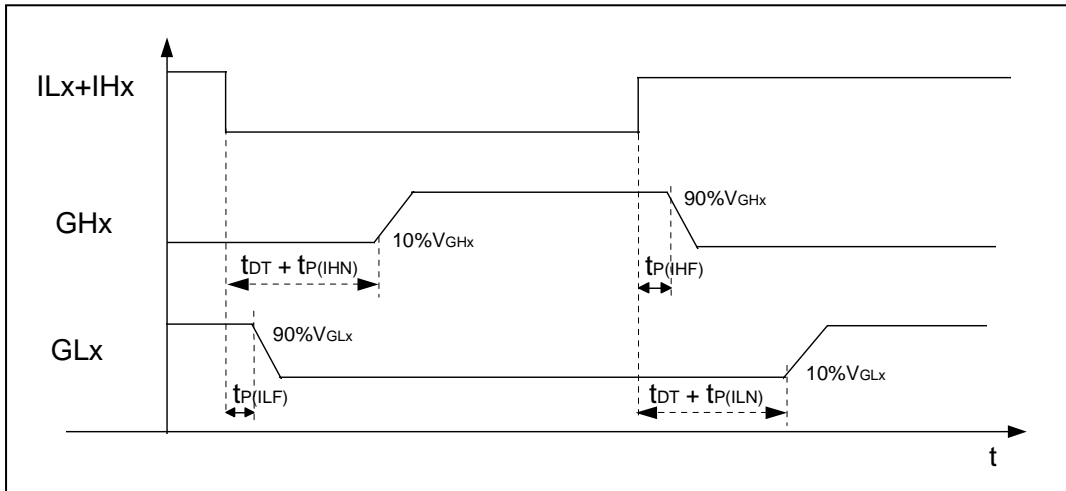

Fig. 6: Dead time generation when IHx and ILx are tied together

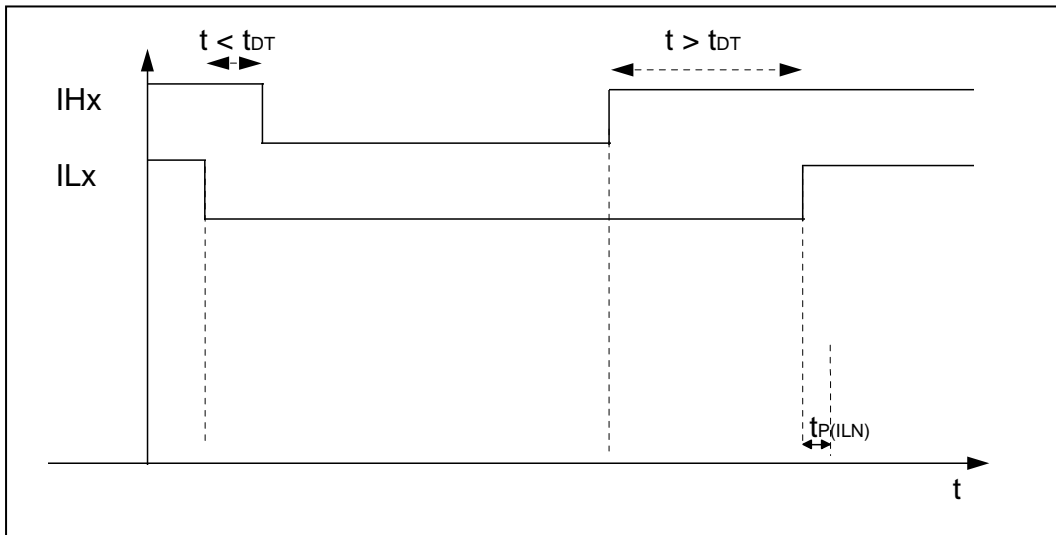

Fig. 7: Dead time generation when IHx and ILx are separated



Fig. 8: Dead time generation and shoot through protection

### Typ. dead time generation

Parameter:  $T_{Junction}$

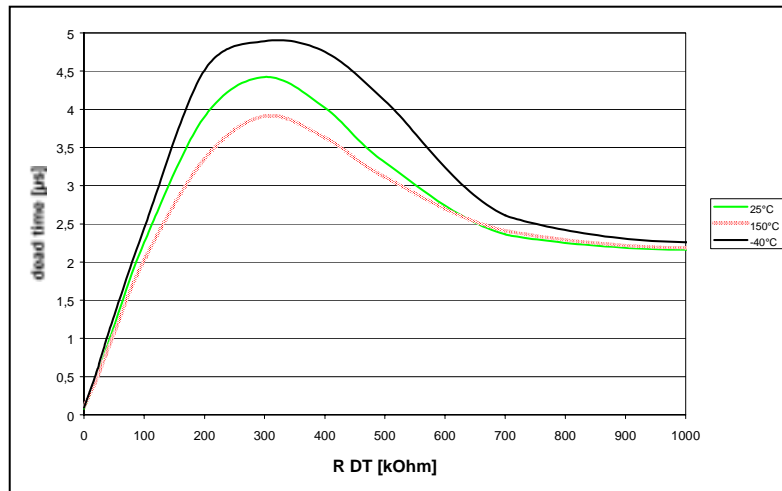

Fig. 9: Typ. dead time internal generated

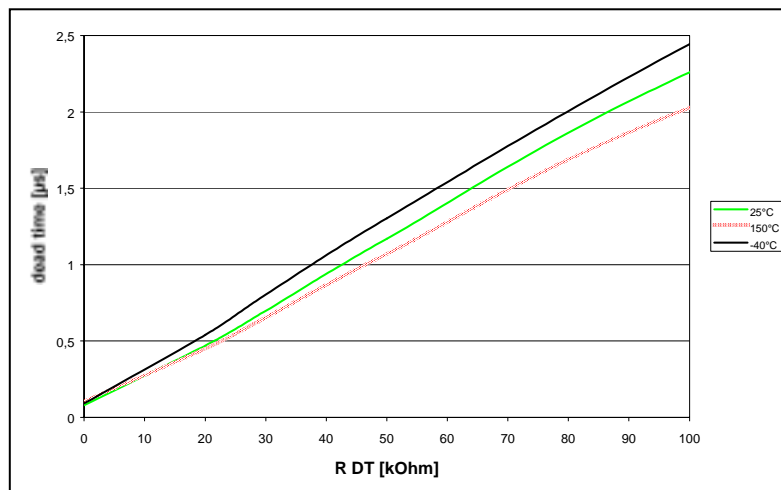
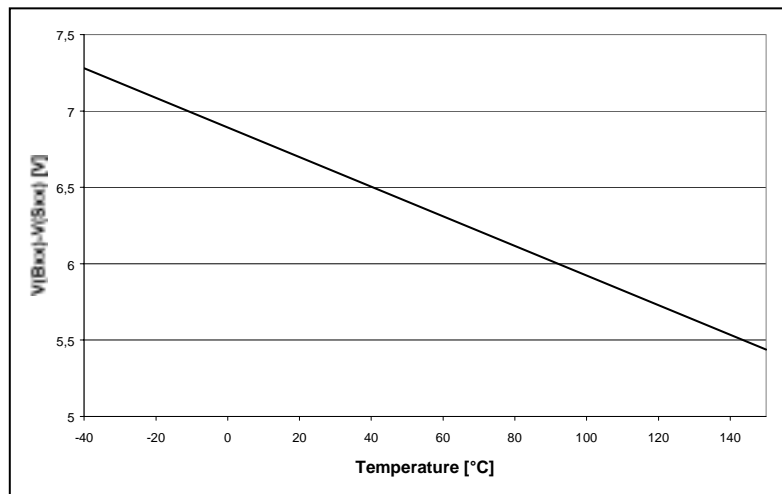

Fig. 10: Typ. dead time internal generated - detail

**Typ. undervoltage shut down level**



**Fig. 11: Typ. undervoltage shut down (Voltage of bootstrap capacitors)**

**Typ. Current consumption of output stage**

Conditions:  $V_s=12V$ ; measured with  $V(BHx)=12V$  and potentiometer between SHx and GND  
 Parameter: MFP voltage /  $T_{Junction}$

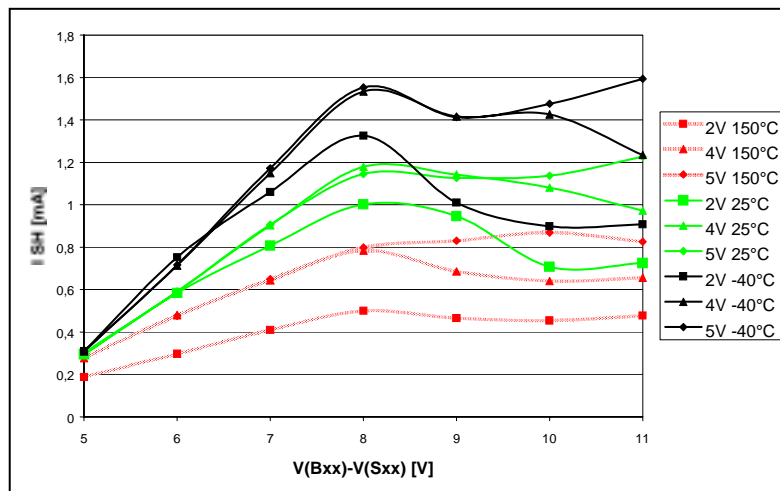

**Fig. 12: Leakage current of driver output stages measured as current out of SH Pin to GND**

**Remark:**

The leakage current of the driver output stage is taken from the bootstrap capacitors  $C_{BX}$ . When an external high-side Mosfet is switched on, it is impossible to replace this current. The capacitor will be discharged as long as this Mosfet stays on. The time until this output stage reaches the undervoltage shut-down can be determined by the size of the capacitor, the initial capacitor voltage, the leakage current taken out of this capacitor and the undervoltage lock-out level.

### Typ. Bootstrap voltage vs. Duty Cycle

Conditions: Mosfet: 6x SPB80N04S2-04;  $f_{PWM}=20kHz$ ,  $V_s=9V$   
 Parameter: Charge pump capacitor  $C_{CP}$  / Bootstrap capacitor  $C_{BX}$

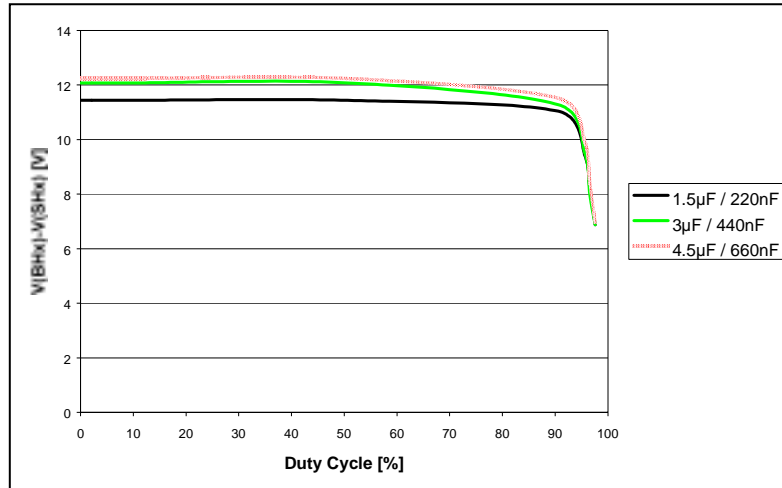

**Fig. 13: Typ. bootstrap voltage  $V(BHx)-V(SHx)$ ; duty cycle of 1 half-bridge = 50%; duty cycle of the other 2 halfbridges variable**

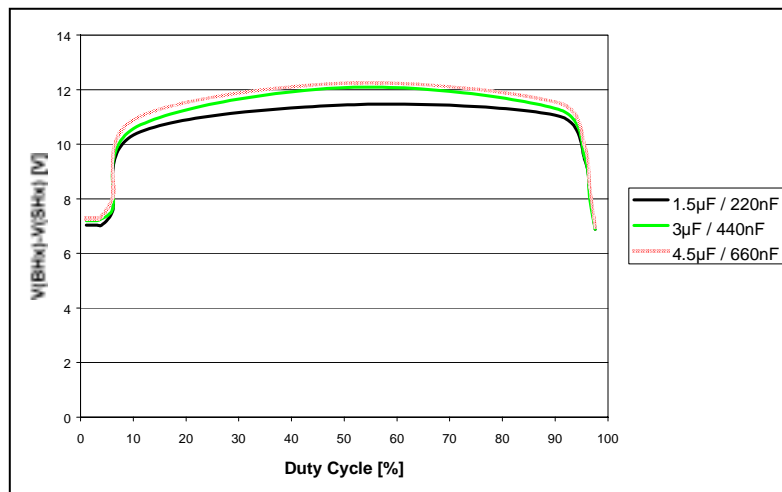

**Fig. 14: Typ. bootstrap voltage  $V(BHx)-V(SHx)$ ; duty cycle of 1 half-bridge = 0%; duty cycle of the other 2 halfbridges variable**

**Remark:**

The reachable duty cycle depends on the used PWM patterns. To achieve an even higher duty cycle, run it for some periods and reduce the duty cycle only for 1 period down to 90% to recharge the bootstrap capacitors.

### Typ. Short circuit detection level

Conditions:  $V_s=12V$   
 Parameter:  $T_{Junction}$

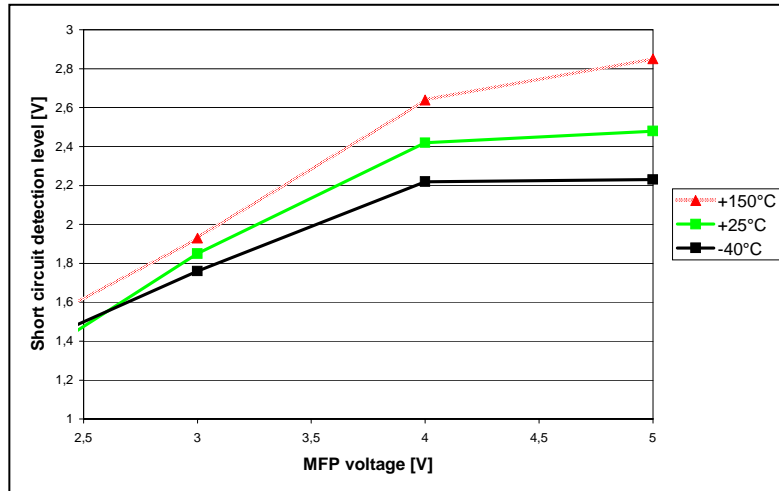

Fig. 15: Short circuit detection level

### Typ. Gate voltage limitation during short circuit detection

Conditions:  $V_s=12V$ ; Load at output: capacitor with 22nF;  $V(SHx) = GND$ ;  $V(SLx) = GND$ ;  
 For HS (high-side output); Short happens during on phase  $V(VDH)-V(SHx)=3V$ ;  
 For LS (low-side output); Short happens during on phase  $V(SHx)-V(SLx)=3V$ ;  
 Parameter:  $T_{Junction}$ ; high-side (HS) or low-side (LS) output

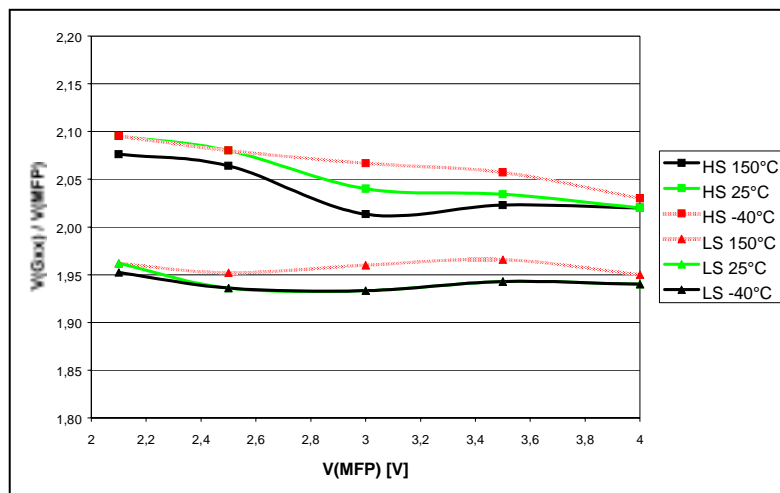

Fig. 16: Factor between reduced gate voltage  $V(G_{xx})$  in case of short circuit and the voltage at the MFP pin

### Typ. Switching behavior

Conditions:  $V_S=12V$ ;  $V_{bb}=12V$ ;  $I_{Load} = 10A$ ;  $V_{MFP}=3.75V$ ;  $R_{Gate} = 1\Omega$ ;  $R_{DT}=10k\Omega$ ;  $C_{Bxx} = 220nF$ ;  $C_{CP}=1,5\mu F$ ; one SPB80N04 S2-04 per output with  $Q_{G(total)} = 135nC$ ; Measured:  $V(DS)$

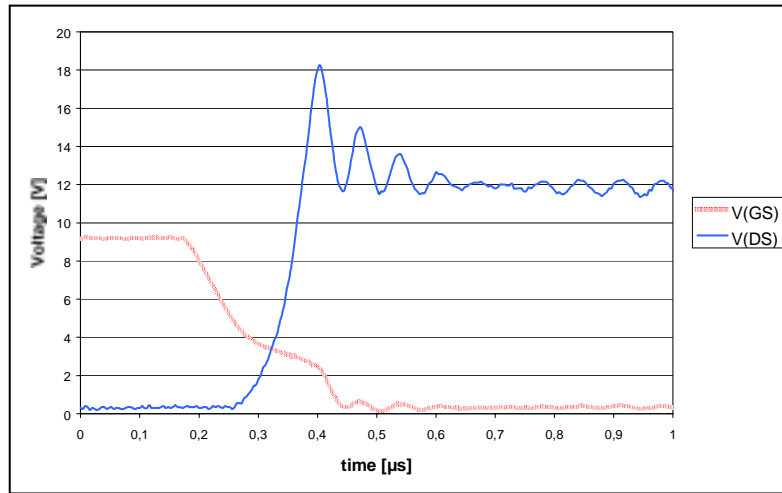

Fig. 17: typ. fall-time at 25°C

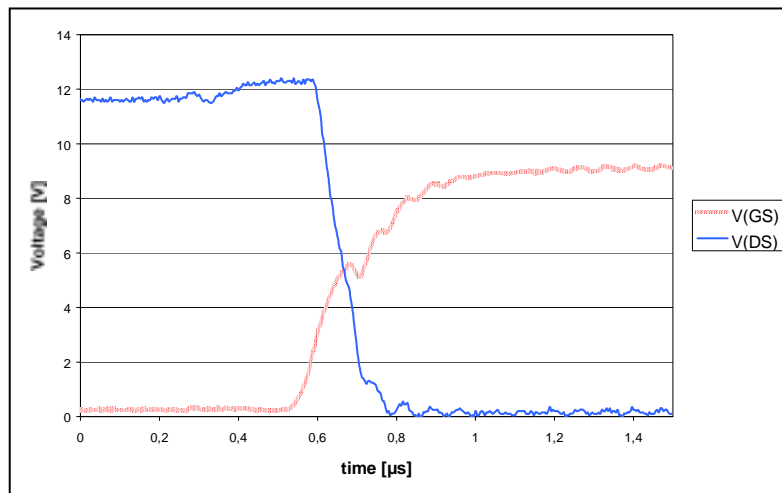

Fig. 18: typ. rise-time at 25°C

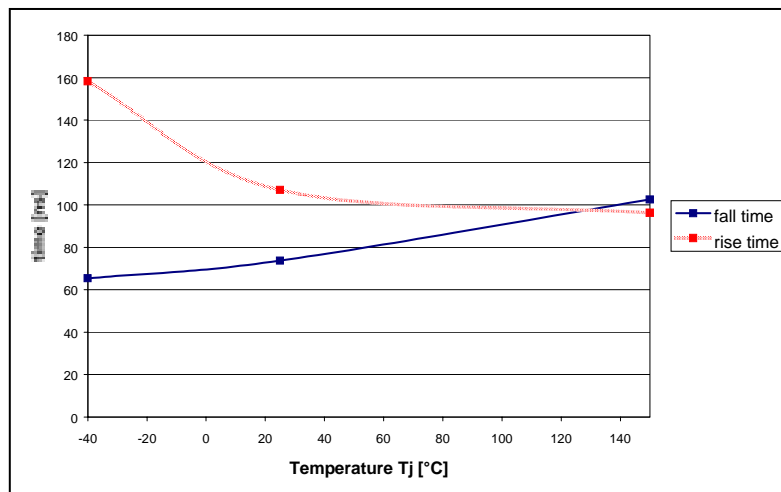
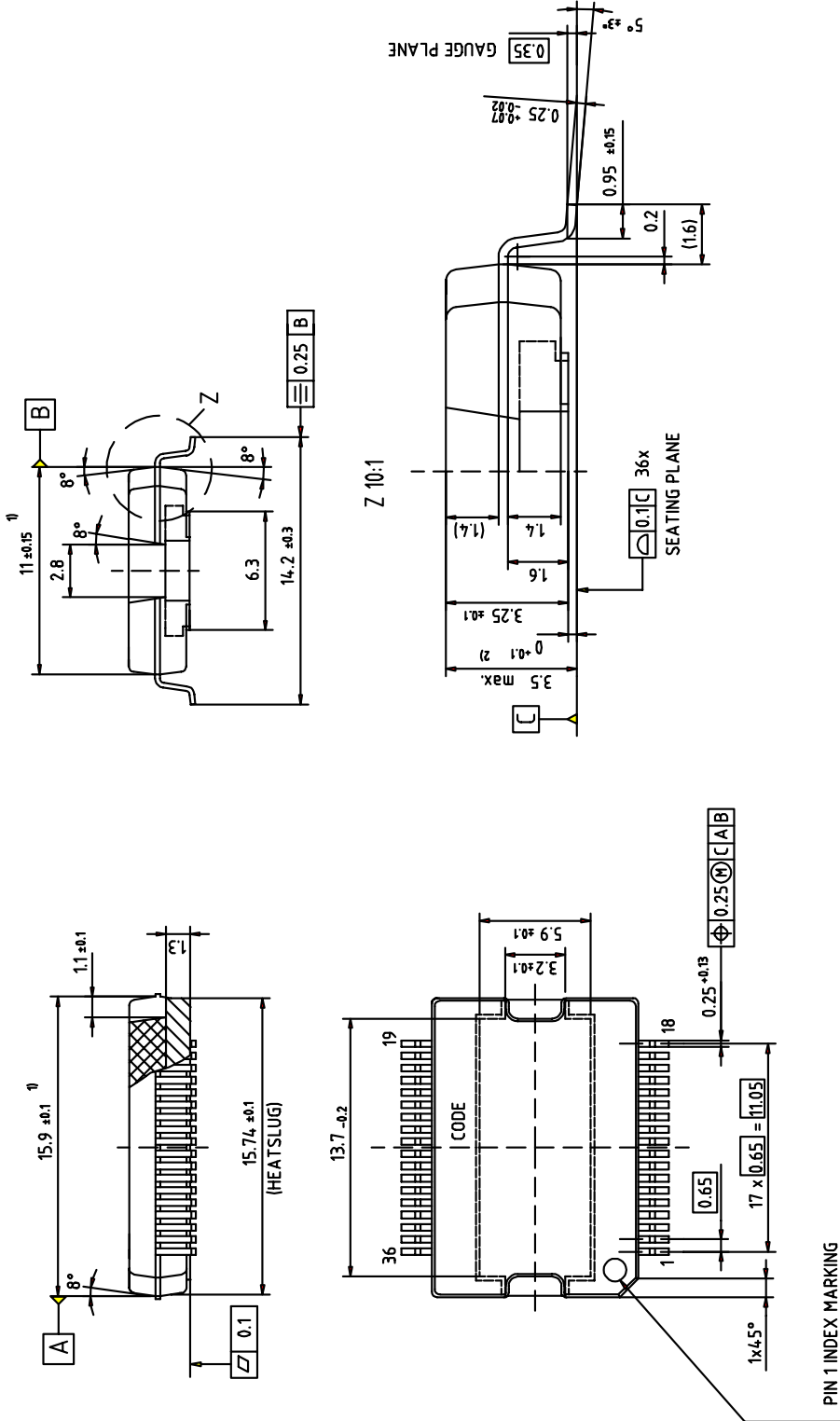

Fig. 19: Rise- and fall-times vs. temperature T<sub>J</sub>

# Package and Ordering Code

Package: P-DSO36-12

(all dimensions in mm)



**Published by  
Infineon Technologies AG,  
Bereich Kommunikation  
St.-Martin-Strasse 53,  
D-81541 München  
© Infineon Technologies AG 1999  
All Rights Reserved.**

**Attention please!**

The information herein is given to describe certain components and shall not be considered as warranted characteristics.

Terms of delivery and rights to technical change reserved.

We hereby disclaim any and all warranties, including but not limited to warranties of non-infringement, regarding circuits, descriptions and charts stated herein.

Infineon Technologies is an approved CECC manufacturer.

**Information**

For further information on technology, delivery terms and conditions and prices please contact your nearest Infineon Technologies Office in Germany or our Infineon Technologies Representatives worldwide (see address list).

**Warnings**

Due to technical requirements components may contain dangerous substances. For information on the types in question please contact your nearest Infineon Technologies Office.

Infineon Technologies Components may only be used in life-support devices or systems with the express written approval of Infineon Technologies, if a failure of such components can reasonably be expected to cause the failure of that life-support device or system, or to affect the safety or effectiveness of that device or system. Life support devices or systems are intended to be implanted in the human body, or to support and/or maintain and sustain and/or protect human life. If they fail, it is reasonable to assume that the health of the user or other persons may be endangered.