

LH1263 E & M Signaling Circuit

Features

- Switches controlled by TTL compatible data inputs
- One switch with 250 mA current-break capability
- Two switches have low ON-resistance
 - $<8 \Omega$ at 250 mA
 - $<35 \Omega$ at 85 mA (current-limit switch)
- No EMI
- 180 mA driver circuit for external relays (TTL compatible)
- Clean, bounce-free switching
- Solid-state reliability
- High-voltage monolithic IC fabricated in a dielectric process

Description

The LH1263AE E & M Signaling Circuit replaces electromechanical relays and discrete components that are utilized in line signaling interface circuits such as E & M trunk signaling and FX ground-start applications. This IC is comprised of logic-programmable, latched switch control; three high-voltage switches (one for overcurrent protection); a ground-reference comparator, and a driver for external relays. The latches store data, which establishes this IC as a Type I, II, III, IV, or V interface. The ground reference comparator and a few resistors provide the E lead and M lead detector. The overcurrent protection eliminates the need for a positive temperature coefficient (PTC) resistor or a ballast lamp on the M lead battery supply.

The LH1263AE device can be configured to perform Type I, II, III, IV, and V interfaces. Multiple ICs are required for some of the interfaces. The LH1263AE device is available in a 20-pin, plastic DIP.

Description (continued)

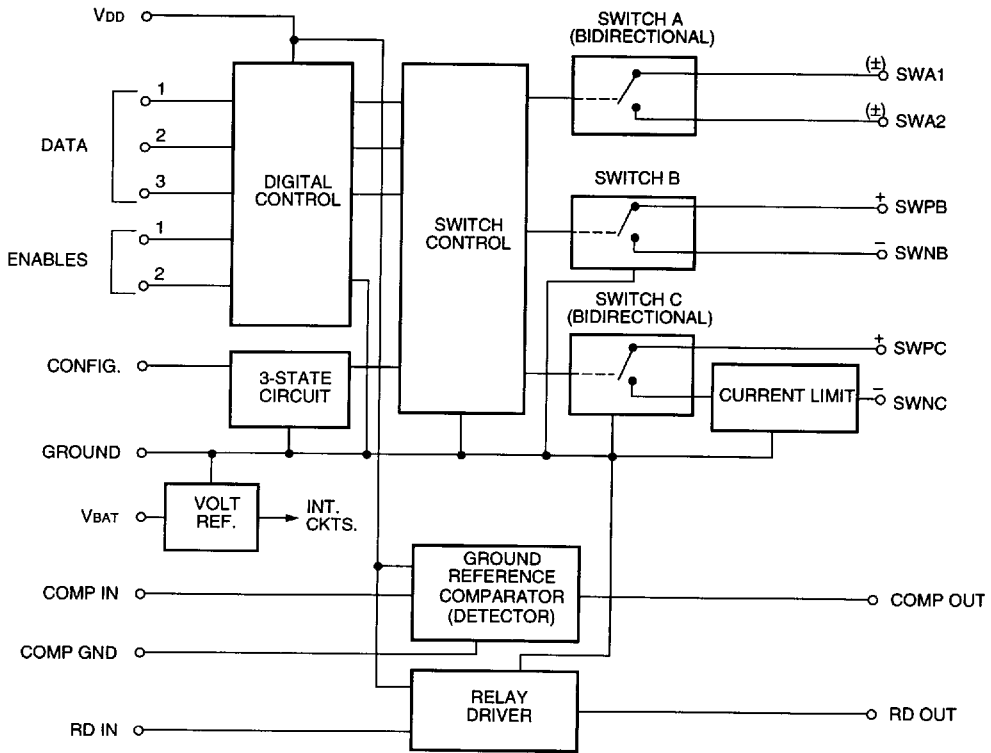

Figure 1. Functional Block Diagram

Pin Information

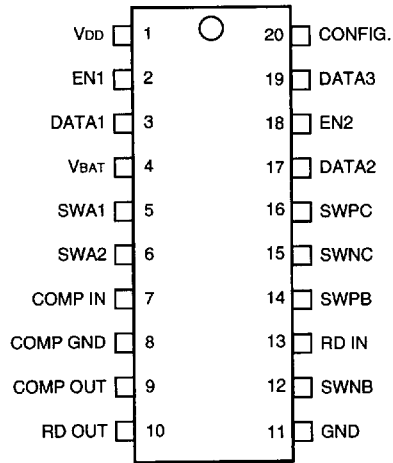

Figure 2. Pin Diagram

Table 1. Pin Descriptions

Pin	Symbol	Name/Function
1	V _{DD}	Positive Supply Voltage. Operating voltage is +5.0 V (± 0.25 V).
2 18	EN1 EN2	ENABLE. These TTL compatible inputs enable (logic-high) or disable (logic-low) inputs DATA1 and DATA3 respectively.
3 17 19	DATA1 DATA2 DATA3	DATA. These TTL-compatible inputs provide the logic for controlling switches 1, 2, and 3.
4	V _{BAT}	V_{BAT}. Connections for the negative external power (operating voltage is -42.5 V to -60 V). This pin is typically connected to a central office supply in telephone applications.
5 6	SWA1 SWA2	Outputs for Bidirectional Switch A. Loads can be connected to these outputs irrespective of polarity.
7 9	COMP IN COMP OUT	Comparator. Ground reference comparator input and output respectively.
8	COMP GND	Comparator Ground. An independent ground or common for the comparator.
10 13	RD OUT RD IN	Relay I/O. Relay output and input respectively.
11	GND	Ground. Common ground point for device circuitry (except the comparator).
12 14	SWNB SWPB	Outputs for Switch B. SWNB and SWPB connect to the negative and positive potentials respectively of a load for Switch B.
15 16	SWNC SWPC	Outputs for Switch C. SWNC and SWPC connect to the negative and positive potentials respectively of a load for Switch C.
20	CONFIG	Configuration. Pin for determining one of three possible logic combinations for switch control (see Table 7).

Absolute Maximum Ratings (T_A = 25 °C)

Stresses in excess of the Absolute Maximum Ratings can cause permanent damage to the device. These are absolute stress ratings only. Functional operation of the device is not implied at these or any other conditions in excess of those given in the operational sections of the data sheet. Exposure to Absolute Maximum Ratings for extended periods of time can adversely affect device reliability.

Table 2. Absolute Maximum Ratings

Parameter	Symbol	Min	Max	Unit
Ambient Operating Temperature Range	T _A	-40	+85	°C
Storage Temperature Range	T _{stg}	-40	+125	°C
Pin Soldering Temperature (t = 15 s max)	T _s	—	300	°C
Supply Voltage (V _{DD} to Common)	V _s	—	5.50	V
Supply Voltage (V _{NEG} to Common)	V _s	-60	—	V
Switch A and B Terminal Voltage	—	-200	+200	V
Switch C Terminal Voltage				
Pin 15 (Pin 16 at GND)	—	-80	+200	V
Pin 16 (Pin 15 at -48 V)	—	-200	+152	V
dc Switch Current Capacity				
Switch A and B	—	—	360	mA
Switch C	—	—	*	mA

* Switch C is current limited between 140 mA and 360 mA.

Table 3. Excessive Fault Conditions

Description	Condition	Specifications	Switch
Fault Current	On	4 A to 0.8 A in 10 ms	A
	On	1.5 A for 1 s	A
	Shutdown	Between 140 mAdc & 360 mAdc	C
Lightning	On/Off	1000 V, 10 x 1000 μs, 2.5 A peak	A
		1000 V, 10 x 1000 μs, 50 mA peak	B, C
Power Cross	On/Off	600 Vrms — 1 s, 1 kΩ	A

Recommended Operating Conditions

Table 4. Supply Voltages

Name	Symbol	Value	Unit
Supply Voltage	V _{DD}	+5.0 ± 0.25	V
Supply Voltage	V _{BAT}	-42.5 to -52.5	V

Table 5. Comparator Operation (BAT/GND Detector)

COMP GND pin is connected to an external ground reference.

Input Voltage at COMP IN*	Resulting Output Voltage at COMP OUT	Operational Conditions at COMP OUT
+50 mV to V _{DD}	2.4 V to V _{DD} (TTL high)	Sources current up to 50 μA
≤ -50 mV	0 V to 0.4 V (TTL low)	Sinks current up to 500 μA

* COMP IN is internally diode clamped to V_{DD} and COMP GND with a maximum current of 20 mA.

Recommended Operating Conditions (continued)

Table 6. Relay Driver Operation

Input Voltage at RD IN	Resulting Output Voltage at RD OUT	Operational Conditions at RD OUT
Low — 0 V to 0.8 V	≤0.9 V	Sinks current ≤ 180 mA
High — 2.2 V to V _{DD}	Open circuit	≤50 μA leakage at ≤ V _{DD}

Electrical Characteristics T_A = 25 °C

Parameter	Test Condition	Min	Typ	Max	Unit
Power Supply Current V _{DD}	Measure I _{VDD} (See Figure 7.)	—	0.5	5.0	mA
Power Supply Current V _{BAT}	Measure I _{BAT} (See Figure 7.)	—	1.6	2.5	mA
Switch A On Voltage	Measure pin 6 = +85 mA (See Figure 8.)	—	1.0	2.0	V
	Measure pin 6 = -85 mA (See Figure 8.)	—	1.0	2.0	V
Switch B On Voltage	Measure pin 14 = 250 mA (See Figure 9.)	—	1.6	2.0	V
Switch C On Voltage	Measure pin 16 = 85 mA (See Figure 10.)	—	2.2	3.0	V
Switch A Break Current*	Pin 6 = +130 mA (See Figure 11.)	—			
	Pin 6 = -130 mA (See Figure 11.)	—			
Switch B Break Current*	Pin 14 = 250 mA (See Figure 12.)	—			
Switch A Leakage Current	V _S = +200 V, Measure +I (See Figure 13.)	—	<1.0	10	μA
	V _S = -200 V, Measure -I (See Figure 13.)	—	<-1.0	-10	μA
	V _S = +152 V, Measure +I (See Figure 14.)	—	<1.0	10	μA
	V _S = -248 V, Measure -I (See Figure 14.)	—	<-1.0	-10	μA
Switch B Leakage Current	V _S = +200 V, Measure +I (See Figure 15.)	—	<1.0	10	μA
	V _S = -200 V, Measure -I (See Figure 15.)	—	<-1.0	-10	μA
	V _S = +152 V, Measure +I (See Figure 16.)	—	<1.0	10	μA
	V _S = -248 V, Measure -I (See Figure 16.)	—	<-1.0	-10	μA
Switch C Leakage Current	V _S = +200 V, Measure +I (See Figure 17.)	—	<1.0	10	μA
	V _S = -80 V, Measure -I (See Figure 17.)	—	<-1.0	-10	μA
	V _S = +152 V, Measure +I (See Figure 18.)	—	<1.0	10	μA
	V _S = -200 V, Measure -I (See Figure 18.)	—	<-1.0	-10	μA
Relay Driver On Voltage	Measure Pin 10 (See Figure 19.)	—	—	0.9	V
Relay Driver Output Leakage Current	(See Figure 20.)	—	—	50	μA
Comparator Output: On Voltage	Measure Pin 9 (See Figure 21.) V _S = -50 mV, Pin 9 = +500 μA	—	—	0.4	V
	Off Voltage V _S = +50 mV, Pin 9 = -50 μA	2.4	—	—	V
Switch C Shutdown†	(See Figure 22.)	—			
Digital Input Low-level Voltage	—	—	—	0.8	V
Digital Input High-level Voltage	—	2.2	—	—	V
Feedthrough Capacitance:	Switch A	—	9.0	—	pF
	Switch B	—	2.0	—	pF
	Switch C	—	65	—	pF

* The test figures show the initial setup conditions (relay in the normally closed position). The relay is activated to complete the break-current capability test.

† This switch has overcurrent protection. Figure 22 describes the fault condition. S1 is to be closed after all other connections have been made. Typical average current on pin 15 during a fault is less than 30 mA. The shutdown current window is between 140 mA and 360 mA.

Typical Characteristic Curves

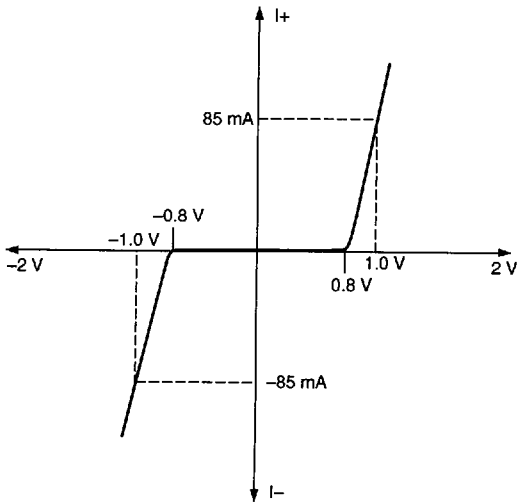

Figure 3. Typical ON Characteristics Switch A

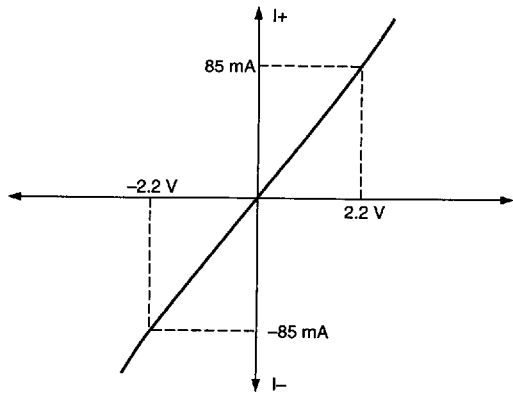

Figure 5. Typical ON Characteristics Switch B

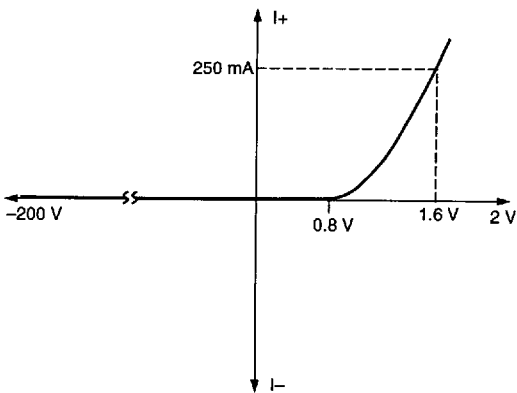

Figure 4. Typical ON Characteristics Switch C

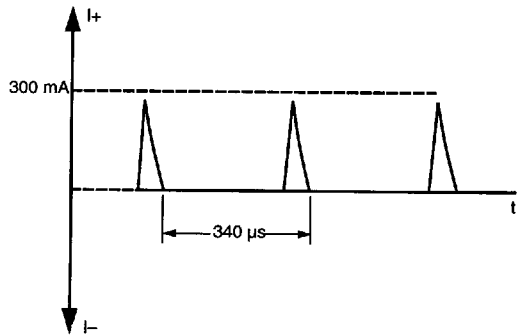

Figure 6. Switch C, Current-Limit Mode

Logic Table

Table 7. Logic Table

Pins EN1 and EN2 are enabled (logic high).

Inputs			CONFIG	Device State		
DATA1	DATA2	DATA3		Switch A	Switch B	Switch C
Low	Low	Low	Ground	Closed	Open	Open
Low	Low	High	Ground	Closed	Open	Open
Low	High	Low	Ground	Open	Open	Open
Low	High	High	Ground	Open	Open	Open
High	Low	Low	Ground	Closed	Open	Open
High	Low	High	Ground	Closed	Closed	Closed
High	High	Low	Ground	Open	Open	Open
High	High	High	Ground	Open	Closed	Closed
Low	Low	Low	N/C	Closed	Open	Open
Low	Low	High	N/C	Closed	Open	Closed
Low	High	Low	N/C	Open	Open	Open
Low	High	High	N/C	Open	Open	Closed
High	Low	Low	N/C	Closed	Open	Open
High	Low	High	N/C	Closed	Open	Closed
High	High	Low	N/C	Open	Closed	Open
High	High	High	N/C	Open	Closed	Closed
Low	Low	Low	VBAT	Closed	Open	Open
Low	Low	High	VBAT	Closed	Open	Closed
Low	High	Low	VBAT	Open	Open	Open
Low	High	High	VBAT	Open	Open	Closed
High	Low	Low	VBAT	Open	Closed	Open
High	Low	High	VBAT	Open	Closed	Closed
High	High	Low	VBAT	Open	Open	Open
High	High	High	VBAT	Open	Open	Closed

Test Circuits

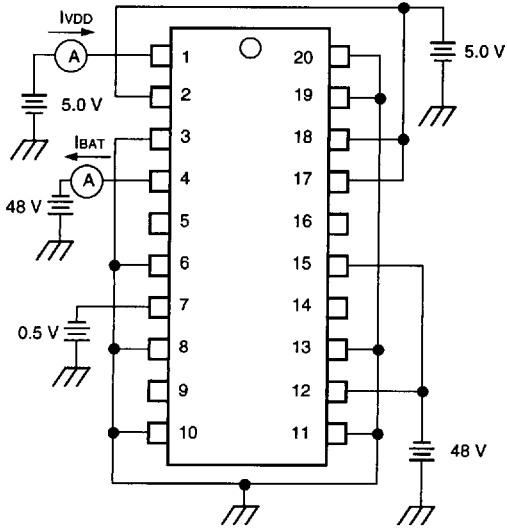

Figure 7. Supply Currents

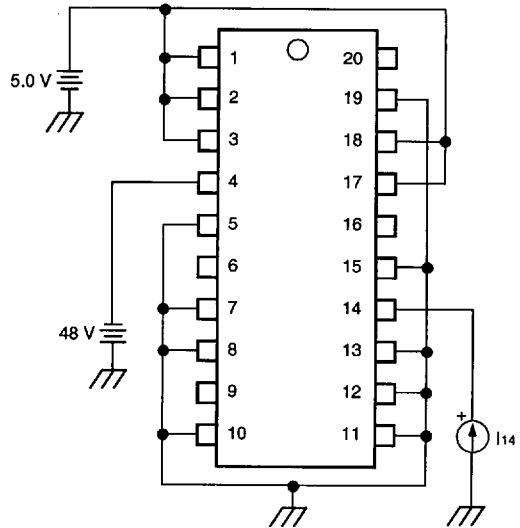

Figure 9. Positive ON Voltage — Switch B

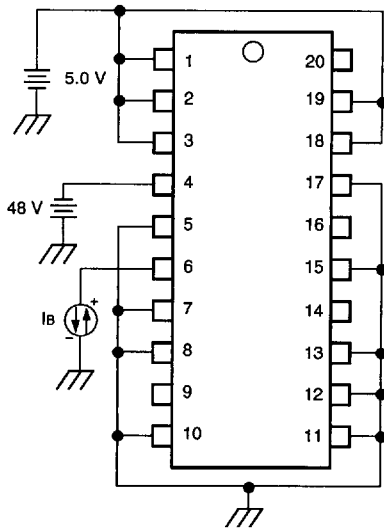

Figure 8. Positive/Negative ON Voltage — Switch A

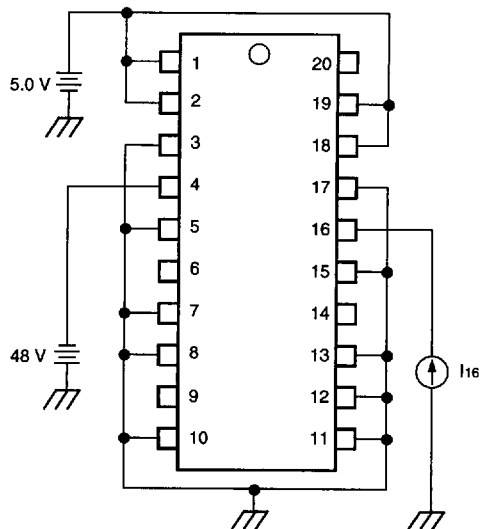

Figure 10. Positive ON Voltage — Switch C

Test Circuits (continued)

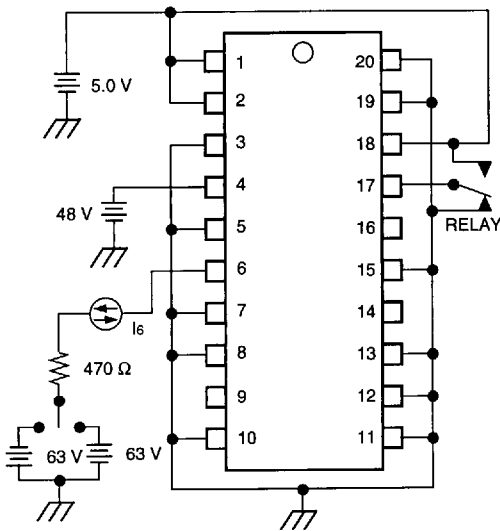

Figure 11. Break-Current Capability — Switch A

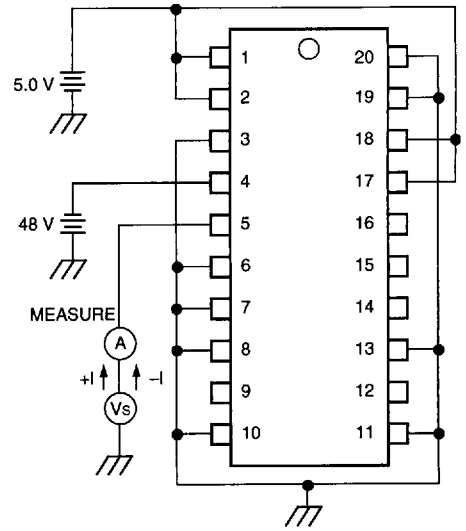

Figure 13. High-Voltage Leakage Current — Switch A

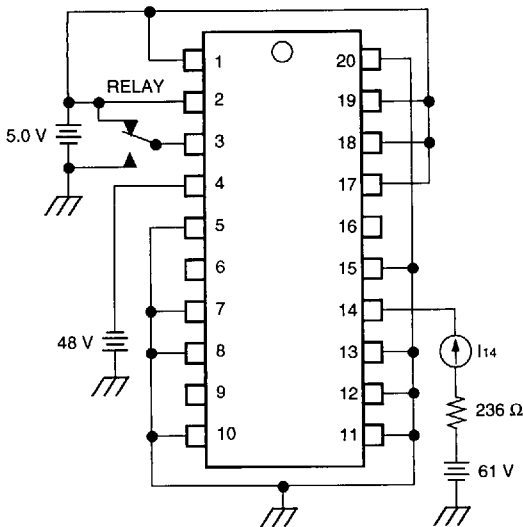

Figure 12. Break-Current Capability — Switch B

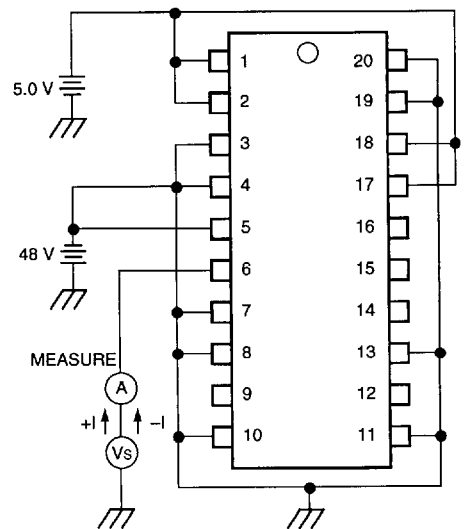

Figure 14. High-Voltage Leakage Current — Switch A

Test Circuits (continued)

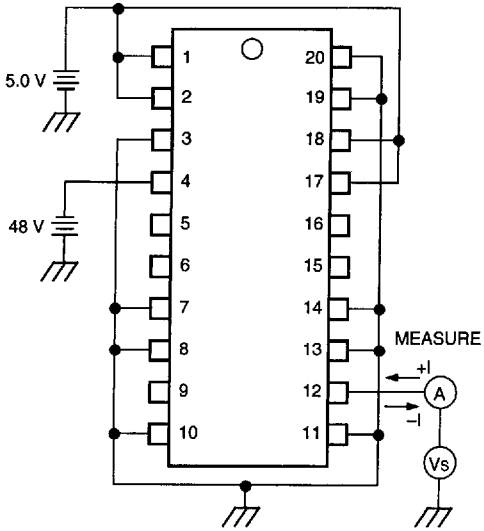

Figure 15. High-Voltage Leakage Current — Switch B

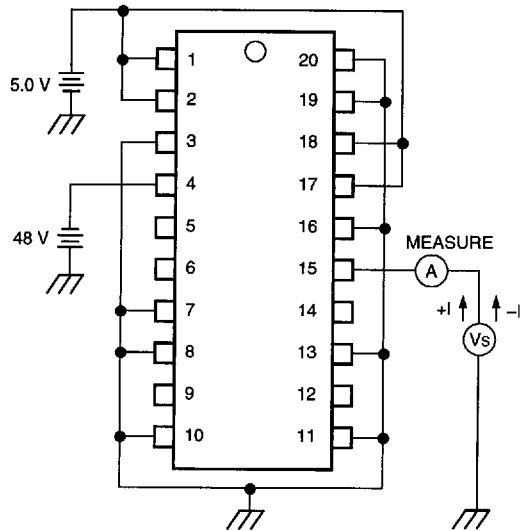

Figure 17. High-Voltage Leakage Current — Switch C

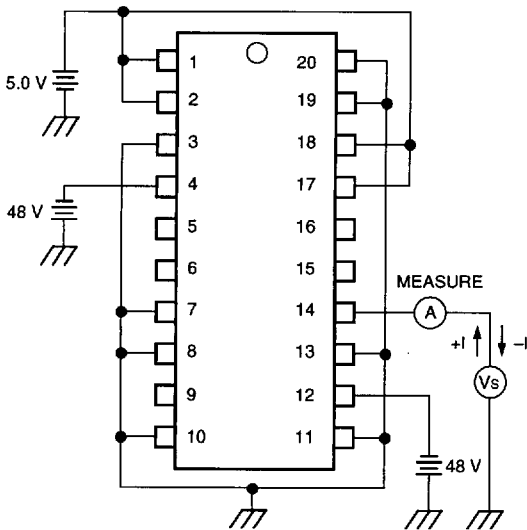

Figure 16. High-Voltage Leakage Current — Switch B

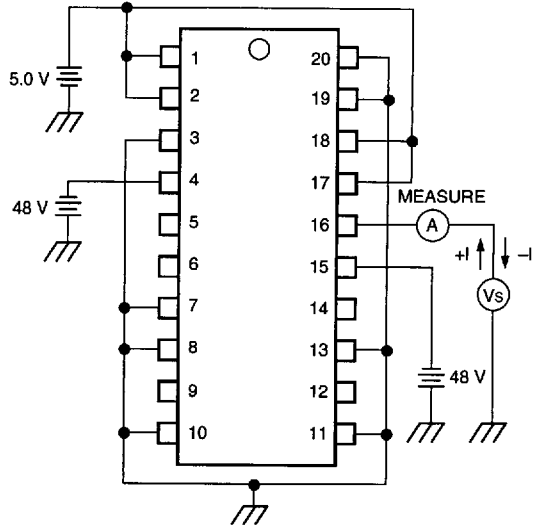

Figure 18. High-Voltage Leakage Current — Switch C

Test Circuits (continued)

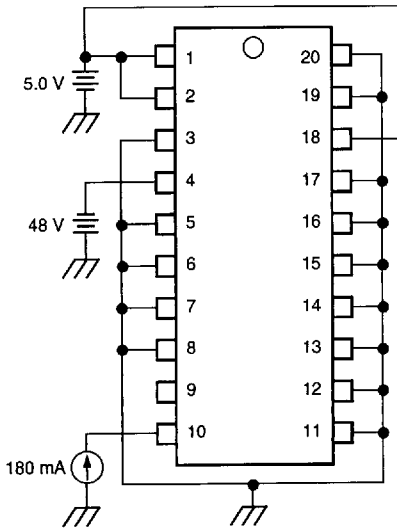

Figure 19. Relay Driver ON Voltage

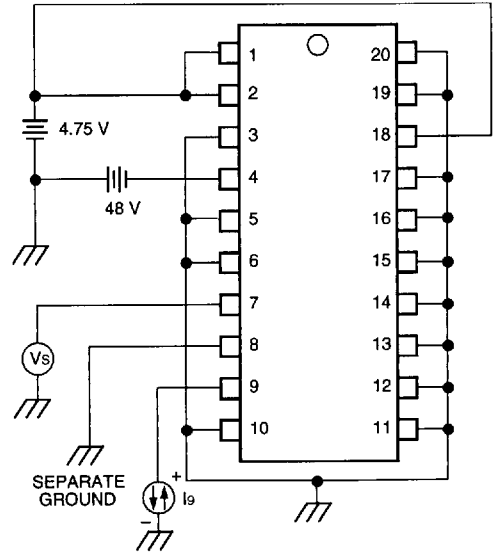

Figure 21. Comparator ON/OFF Voltage

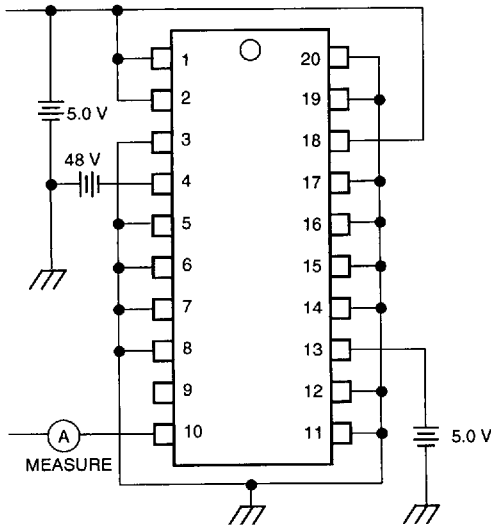

Figure 20. Relay Driver Output, Leakage Current

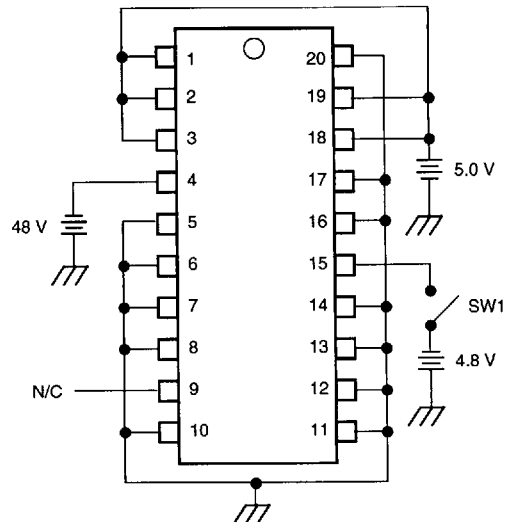

Figure 22. Switch C Shutdown Test

Simplified Output Circuits

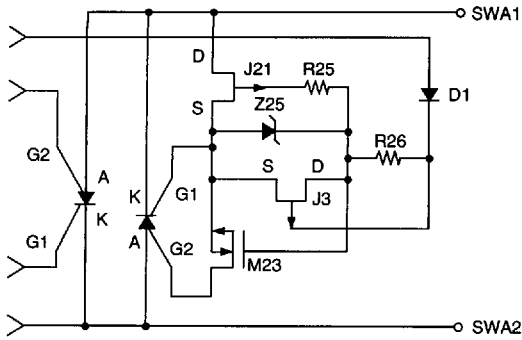

Figure 23. Switch A Output

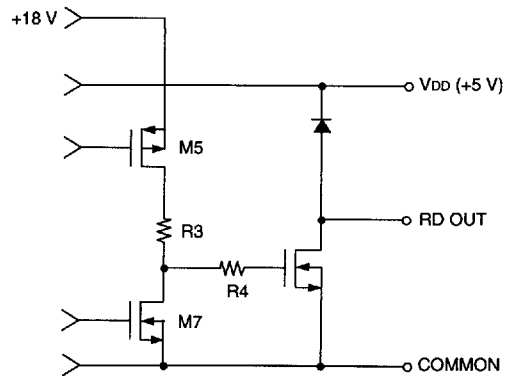

Figure 26. Relay Driver Output

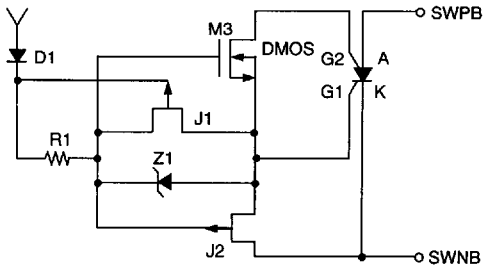

Figure 24. Switch B Output

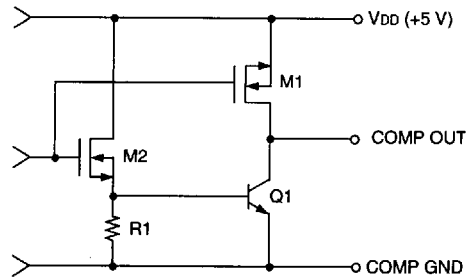

Figure 27. Comparator (Detector) Output

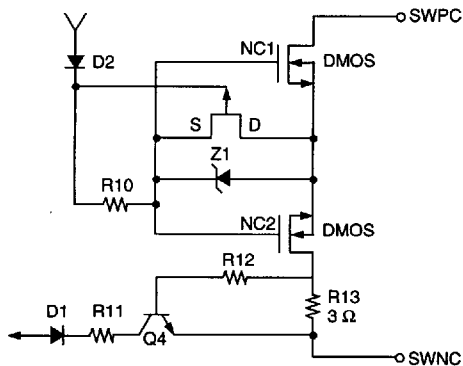

Figure 25. Switch C Output

Applications

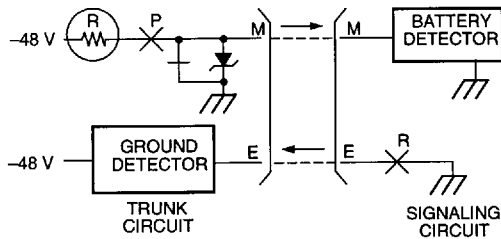

Figure 28. Type I Interface

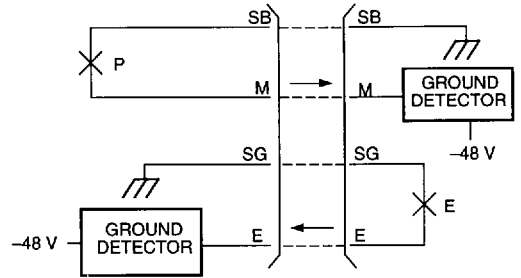

Figure 31. Type IV Interface

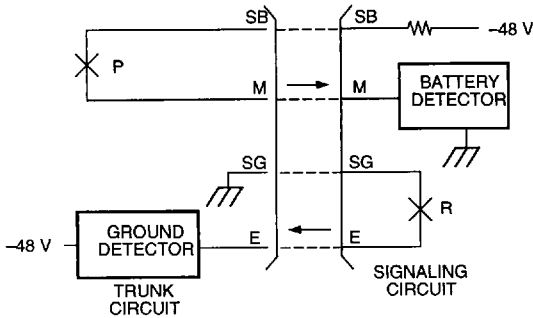

Figure 29. Type II Interface

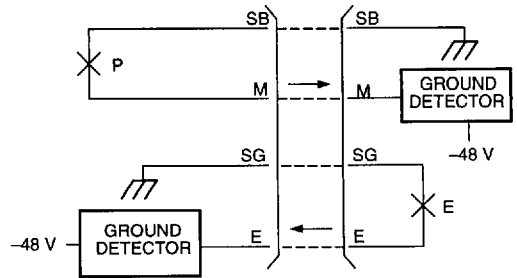

Figure 32. Type V Interface

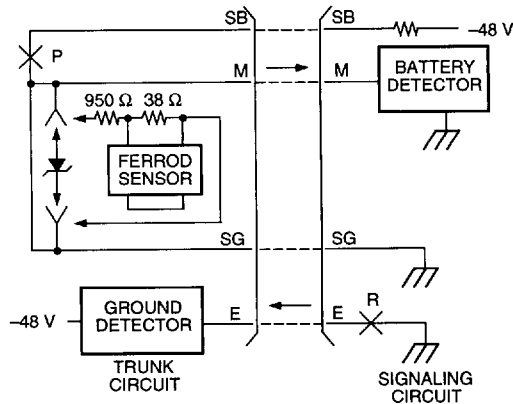
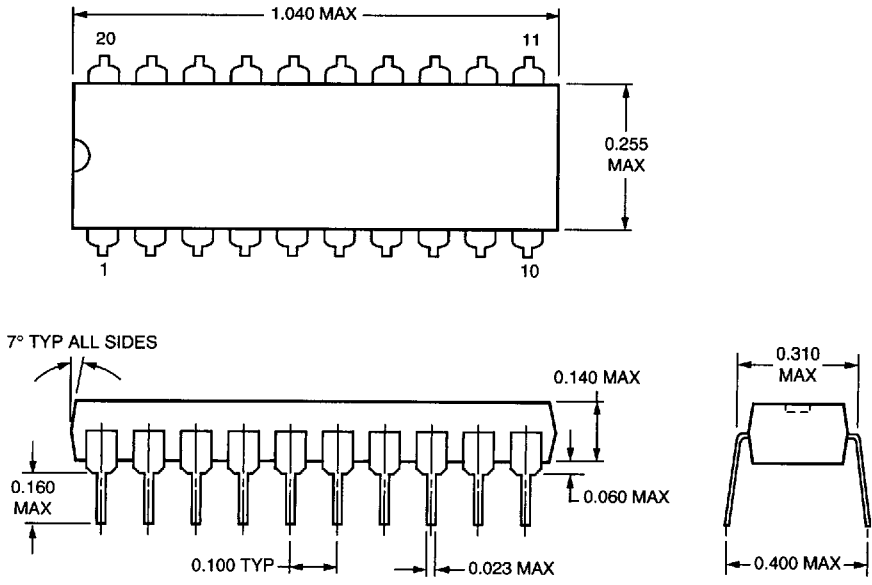

Figure 30. Type III Interface

Outline Diagrams

20-Pin Plastic DIP (LH1263AE)

Dimensions are in inches and (millimeters).



Packaging and Ordering Information

Throughout this section the following abbreviations are used:

DIP — Dual in-line package; SOG — Small-outline gull wing; SOJ — Small-outline J-lead; SONB — Small-outline narrow body; PLCC — Plastic leaded chip carrier.

Device Code	Package Type	Temperature
ATTL7551AP	44-Pin PLCC	-40 °C to +85 °C
ATTL7551AF	24-Pin DIP	-40 °C to +85 °C
ATTL7554AP	44-Pin PLCC	-40 °C to +85 °C
ATTL7556AAU	32-Pin PLCC	-40 °C to +85 °C
ATTL7557AAU		
ATTL7561AP	44-Pin PLCC	-40 °C to +85 °C
ATTL7564AP		
ATTL7581AC/BC	16-Pin DIP	-40 °C to +85 °C
ATTL7581AAE/BAE	16-Pin Plastic SOG	-40 °C to +85 °C
ATTL7582AE/BE	16-Pin Plastic DIP	-40 °C to +85 °C
ATTL7582AAE/BAE	16-Pin Plastic SOG	-40 °C to +85 °C
ATTL7583AF/BF	24-Pin Plastic DIP (600 mil)	-40 °C to +85 °C
ATTL7583ACG/BCG	24-Pin Plastic DIP (300 mil)	-40 °C to +85 °C
ATTL7583AAJ/BAJ	28-Pin Plastic SOG	-40 °C to +85 °C
ATTL7590AAF	14-Pin	-40 °C to +85 °C
ATTL7591AB	8-Pin, DIP	-40 °C to +85 °C
ATTL7591AS	8-Pin, SONB	-40 °C to +85 °C
LB1011AB	8-Pin, DIP	-20 °C to +70 °C
LB1013AD	18-Pin, DIP	-25 °C to +85 °C
LB1060AB	8-Pin, DIP	-40 °C to +65 °C
LB1201AB	8-Pin, DIP	-40 °C to +85 °C
LB1201AS	8-Pin, SONB	-40 °C to +85 °C
LB1208AAJ	28-pin SOG	-40 °C to +85 °C
LB1276AP	44-Pin PLCC	-40 °C to +85 °C
LB1276AF	24-Pin DIP	-40 °C to +85 °C
LB1356AF	24-Pin DIP	-40 °C to +85 °C
LH1263AR	20-Pin Plastic DIP	-40 °C to +85 °C
LH1571AB	8-pin Plastic DIP	-40 °C to +85 °C
LH1571AAC	8-pin SOG	-40 °C to +85 °C
T - 7503 - - - EL	20-Pin, SOJ	-40 °C to +85 °C
T - 7503 - - 1EC	20-Pin, SOJ	0 °C to 70 °C
T - 7504 - - - PL	28-Pin, DIP	-40 °C to +85 °C
T - 7504 - - - ML	28-Pin, PLCC	-40 °C to +85 °C
T - 5504 - - - PL	28-Pin, DIP	-40 °C to +85 °C
T - 5504 - - - ML	28-Pin, PLCC	-40 °C to +85 °C
T - 7513B - - EE	20-Pin, SOJ	-40 °C to +85 °C
T - 7513B - - PE	20-Pin, DIP	-40 °C to +85 °C
T - 7517A - - EE	16-Pin, DIP	-40 °C to +85 °C
T - 7517A - - PE	16-Pin, SOJ	-40 °C to +85 °C
T - 7548 - - - ME2	28-Pin, PLCC	0 °C to 85 °C
T - 7570 - - - ML2	28-Pin, PLCC	-40 °C to +85 °C