

8-BIT SINGLE-CHIP MICROCOMPUTER

The μ PD78042F, μ PD78043F, μ PD78044F, and μ PD78045F are 8-bit single-chip microcomputers that incorporate many hardware peripherals such as an FIP[®] controller/driver, 8-bit resolution A/D converter, timer, serial interface, and interrupt controller.

The one-time PROM and EPROM models that can operate in the same voltage range as that of masked ROM models, and various development tools are provided.

The functions of these microcomputers are described in detail in the following User's Manual. Be sure to read this manual when you design a system using any of these microcomputers.

μ PD78044F Sub-Series User's Manual : U10908E
78K/0 Series User's Manual, Instruction: IEU-1372

FEATURES

- High-capacity ROM and RAM

Item Product name	Program memory (ROM)	Data memory		
		Internal high-speed RAM	Buffer RAM	FIP display RAM
μ PD78042F	16K bytes	512 bytes	64 bytes	48 bytes
μ PD78043F	24K bytes			
μ PD78044F	32K bytes	1024 bytes		
μ PD78045F	40K bytes			

- Wide range of instruction execution time - from high-speed (0.4 μ s) to ultra low-speed (122 μ s)
- I/O ports: 68
- FIP controller/driver: total display outputs: 34
- 8-bit resolution A/D converter: 8 channels
- Serial interface: 2 channels
- Timer: 6 channels
- Power supply voltage: $V_{DD} = 2.7$ to 5.5 V

★

APPLICATIONS

CD players, cassette tape recorders, tuners, minicomponent stereos, VCRs, microwave ovens, ECRs, etc.

ORDERING INFORMATION

Part number	Package
μ PD78042FGF-xxx-3B9	80-pin plastic QFP (14 × 20 mm)
μ PD78043FGF-xxx-3B9	80-pin plastic QFP (14 × 20 mm)
μ PD78044FGF-xxx-3B9	80-pin plastic QFP (14 × 20 mm)
μ PD78045FGF-xxx-3B9	80-pin plastic QFP (14 × 20 mm)

Remark xxx indicates ROM code number.

The information in this document is subject to change without notice.

★ 78K/0 SERIES PRODUCT DEVELOPMENT

The 78K/0 series products were developed as shown below. The sub-series names are indicated in frames.

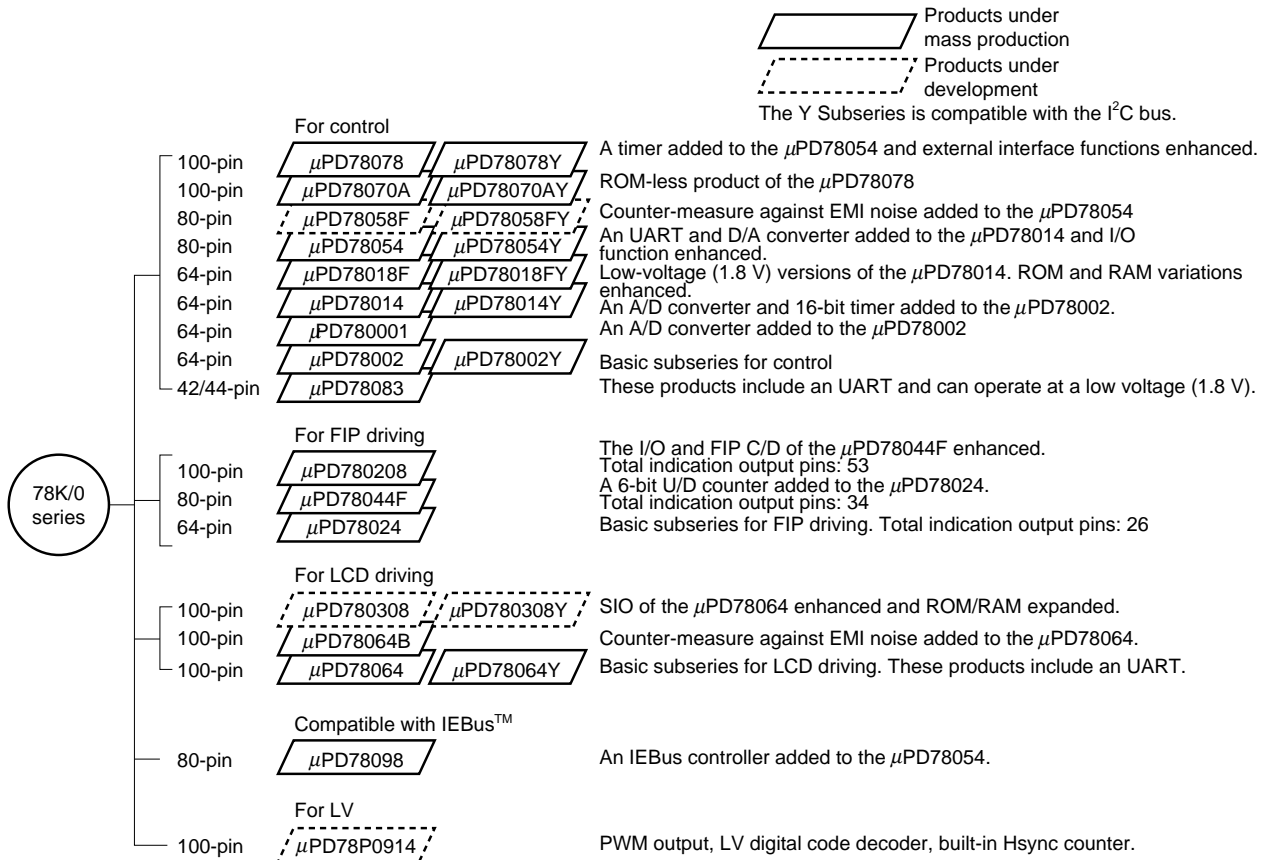

The table below shows the main differences between subseries.

Function Subseries name		ROM capacity	Timer				8-bit A/D	8-bit D/A	Serial interface	I/O	V _{DD} Min. value	External expansion
			8-bit	16-bit	Watch	WDT						
For control	μPD78078	32K-60K	4ch	1ch	1ch	1ch	8ch	2ch	3ch (UART : 1ch)	88 pins	1.8 V	○
	μPD78070A	–								61 pins	2.7 V	
	μPD78058F	48K-60K	2ch	–	–	–	–	2ch	69 pins	2.0 V		
	μPD78054	16K-60K										
	μPD78018F	8K-60K							53 pins	1.8 V		
	μPD78014	8K-32K	–	–	–	–	–	1ch	39 pins	2.7 V	–	
	μPD780001	8K										
	μPD78002	8K-16K							53 pins	○		
	μPD78083	8K-16K	8ch	1ch (UART : 1ch)	33 pins	1.8 V	–					
For FIP driving	μPD780208	32K-60K	2ch	1ch	1ch	1ch	8ch	–	2ch	74 pins	2.7 V	–
	μPD78044F	16K-40K								68 pins		
	μPD78024	24K-32K								54 pins		
For LCD driving	μPD780308	48K-60K	2ch	1ch	1ch	1ch	8ch	–	3ch (UART : 1ch)	57 pins	1.8 V	–
	μPD78064B	32K							2ch (UART : 1ch)	2.0 V		
	μPD78064	16K-32K										
Compatible with IEBus	μPD78098	32K-60K	2ch	1ch	1ch	1ch	8ch	2ch	3ch (UART : 1ch)	69 pins	2.7 V	○
For LV	μPD78P0914	32K	6ch	–	–	1ch	8ch	–	2ch	54 pins	4.5 V	○

★

★

★

FUNCTIONAL OUTLINE

Product name		μPD78042F	μPD78043F	μPD78044F	μPD78045F
Internal memory	ROM	16K bytes	24K bytes	32K bytes	40K bytes
	Internal high-speed RAM	512 bytes		1024 bytes	
	Buffer RAM	64 bytes			
	FIP display RAM	48 bytes			
General registers		8 bits × 32 registers (8 bits × 8 registers × 4 banks)			
Instruction cycle	Variable instruction execution time				
	For main system clock	0.4 μs/0.8 μs/1.6 μs/3.2 μs/6.4 μs (at 5.0 MHz)			
	For subsystem clock	122 μs (at 32.768 kHz)			
Instruction set		<ul style="list-style-type: none"> • Multiplication/division (8 bits × 8 bits, 16 bits ÷ 8 bits) • Bit (set, reset, test, Boolean algebra) 			
I/O ports (including those multiplexed with FIP pins)		<p>Total : 68 lines</p> <ul style="list-style-type: none"> • CMOS input : 2 lines • CMOS I/O : 27 lines • N-ch open-drain : 5 lines • P-ch open-drain I/O : 16 lines • P-ch open-drain output : 18 lines 			
FIP controller/driver		<p>Total : 34 lines</p> <ul style="list-style-type: none"> • Segments : 9 to 24 lines • Digits : 2 to 16 lines 			
A/D converter		<ul style="list-style-type: none"> • 8-bit resolution × 8 channels • Power supply voltage: AV_{DD} = 4.0 to 5.5 V 			
Serial interface		<ul style="list-style-type: none"> • 3-wire serial I/O/SBI/2-wire serial I/O selectable modes: 1 channel • 3-wire serial I/O mode (with automatic transmission/reception function of up to 64 bytes) : 1 channel 			
Timer		<ul style="list-style-type: none"> • 16-bit timer/event counter : 1 channel • 8-bit timer/event counter : 2 channels • Watch timer : 1 channel • Watchdog timer : 1 channel • 6 bit up/down counter : 1 channel 			
Timer output		3 lines (one for 14-bit PWM output)			
Clock output		19.5 kHz, 39.1 kHz, 78.1 kHz, 156 kHz, 313 kHz, 625 kHz (Main system clock: at 5.0 MHz) 32.768 kHz (Subsystem clock: at 32.768 kHz)			
Buzzer output		1.2 kHz, 2.4 kHz, 4.9 kHz (Main system clock: at 5.0 MHz)			
Vectored interrupt	Maskable interrupt	Internal 10 lines, external 4 lines			
	Non-maskable interrupt	Internal 1 line			
	Software interrupt	1 line			
Text input		Internal 1 line			
Power supply voltage		V _{DD} = 2.7 to 5.5 V			
Package		80-pin plastic QFP (14 × 20 mm)			

★

★

CONTENTS

1. PIN CONFIGURATION (TOP VIEW)	6	
2. BLOCK DIAGRAM	8	
3. PINS FUNCTIONS	9	
3.1 PORT PINS	9	
3.2 PINS OTHER THAN PORT PINS	11	
3.3 PIN I/O CIRCUITS AND PROCESSING OF UNUSED PINS	13	
4. MEMORY SPACE	16	
5. PERIPHERAL HARDWARE FUNCTIONS	17	
5.1 PORTS	17	
5.2 CLOCK GENERATOR CIRCUIT	18	
5.3 TIMER/EVENT COUNTER	18	
5.4 CLOCK OUTPUT CONTROL CIRCUIT	21	
5.5 BUZZER OUTPUT CONTROL CIRCUIT	21	
5.6 A/D CONVERTER	22	
5.7 SERIAL INTERFACE	22	
5.8 FIP CONTROLLER/DRIVER	24	
6. INTERRUPT FUNCTION AND TEST FUNCTION	26	
6.1 INTERRUPT FUNCTION	26	
6.2 TEST FUNCTION	29	
7. STANDBY FUNCTION	30	
8. RESET FUNCTION	30	
9. INSTRUCTION SET	31	
10. ELECTRICAL SPECIFICATIONS	34	★
11. CHARACTERISTIC CURVE (REFERENCE VALUE)	58	★
12. PACKAGE DRAWING	63	
13. RECOMMENDED SOLDERING CONDITIONS	64	★
APPENDIX A DEVELOPMENT TOOLS	65	
APPENDIX B RELATED DOCUMENTS	67	

1. PIN CONFIGURATION (TOP VIEW)

- 80-pin plastic QFP (14 × 20 mm)
 μPD78042FGF-xxx-3B9, μPD78043FGF-xxx-3B9
 μPD78044FGF-xxx-3B9, μPD78045FGF-xxx-3B9

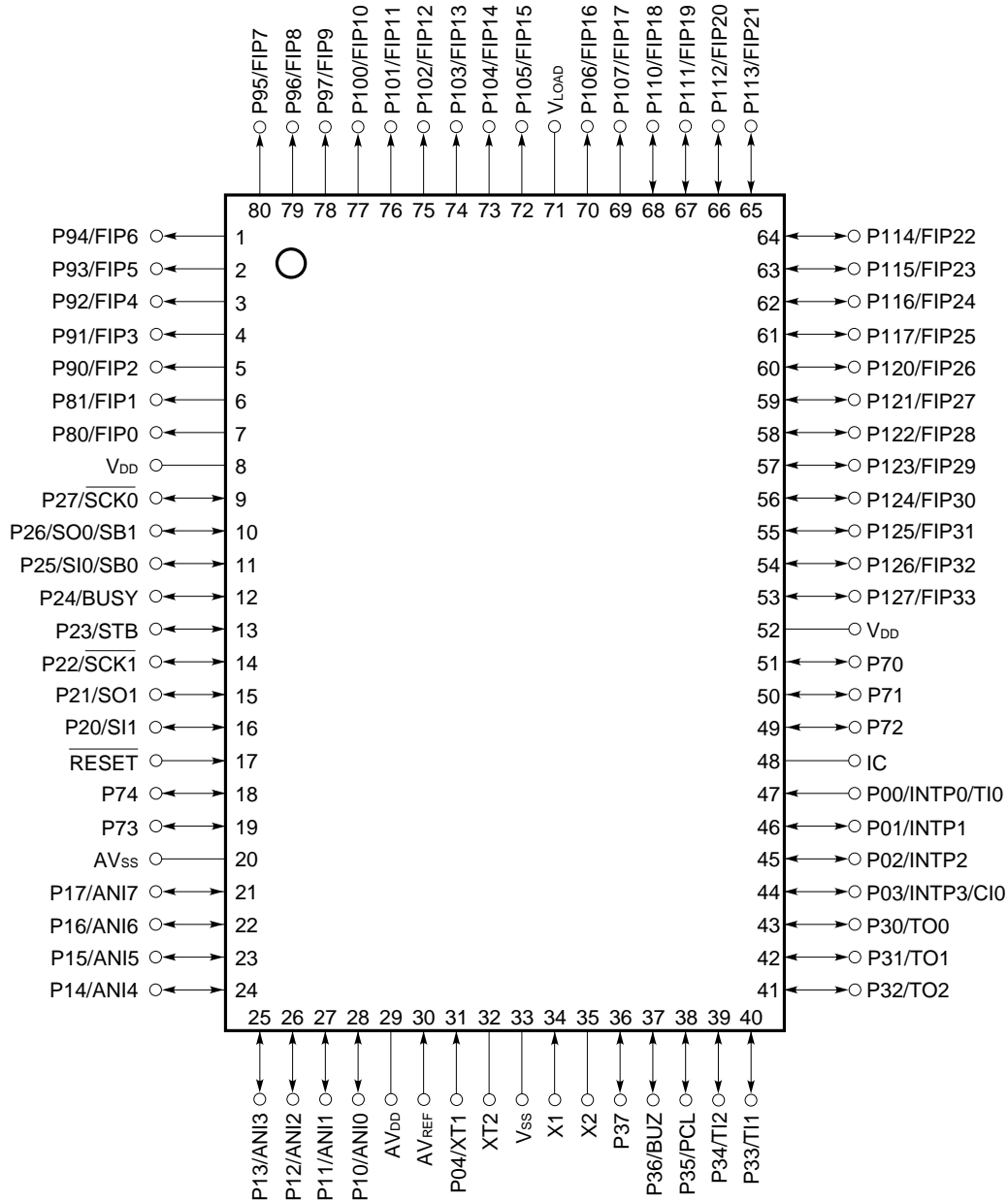

- Cautions**
1. Connect the IC (Internally Connected) pins directly to the V_{SS}.
 2. Connect the AV_{DD} pin to the V_{DD} pin.
 3. Connect the AV_{SS} pin to the V_{SS} pin.

P00-P04	: Port 0	$\overline{\text{SCK0}}, \overline{\text{SCK1}}$: Serial clock
P10-P17	: Port 1	PCL	: Programmable clock
P20-P27	: Port 2	BUZ	: Buzzer clock
P30-P37	: Port 3	STB	: Strobe
P70-P74	: Port 7	BUSY	: Busy
P80, P81	: Port 8	FIP0-FIP33	: Fluorescent indicator panel
P90-P97	: Port 9	V _{LOAD}	: Negative power supply
P100-P107	: Port 10	X1, X2	: Crystal (main system clock)
P110-P117	: Port 11	XT1, XT2	: Crystal (subsystem clock)
P120-P127	: Port 12	$\overline{\text{RESET}}$: Reset
INTP0-INTP3	: Interrupt from peripherals	ANI0-ANI7	: Analog input
TI0-TI2	: Timer input	AV _{DD}	: Analog power supply
TO0-TO2	: Timer output	AV _{SS}	: Analog ground
CI0	: Counter input	AV _{REF}	: Analog reference voltage
SB0, SB1	: Serial bus	V _{DD}	: Power supply
SI0, SI1	: Serial input	V _{SS}	: Ground
SO0, SO1	: Serial output	IC	: Internally connected

2. BLOCK DIAGRAM

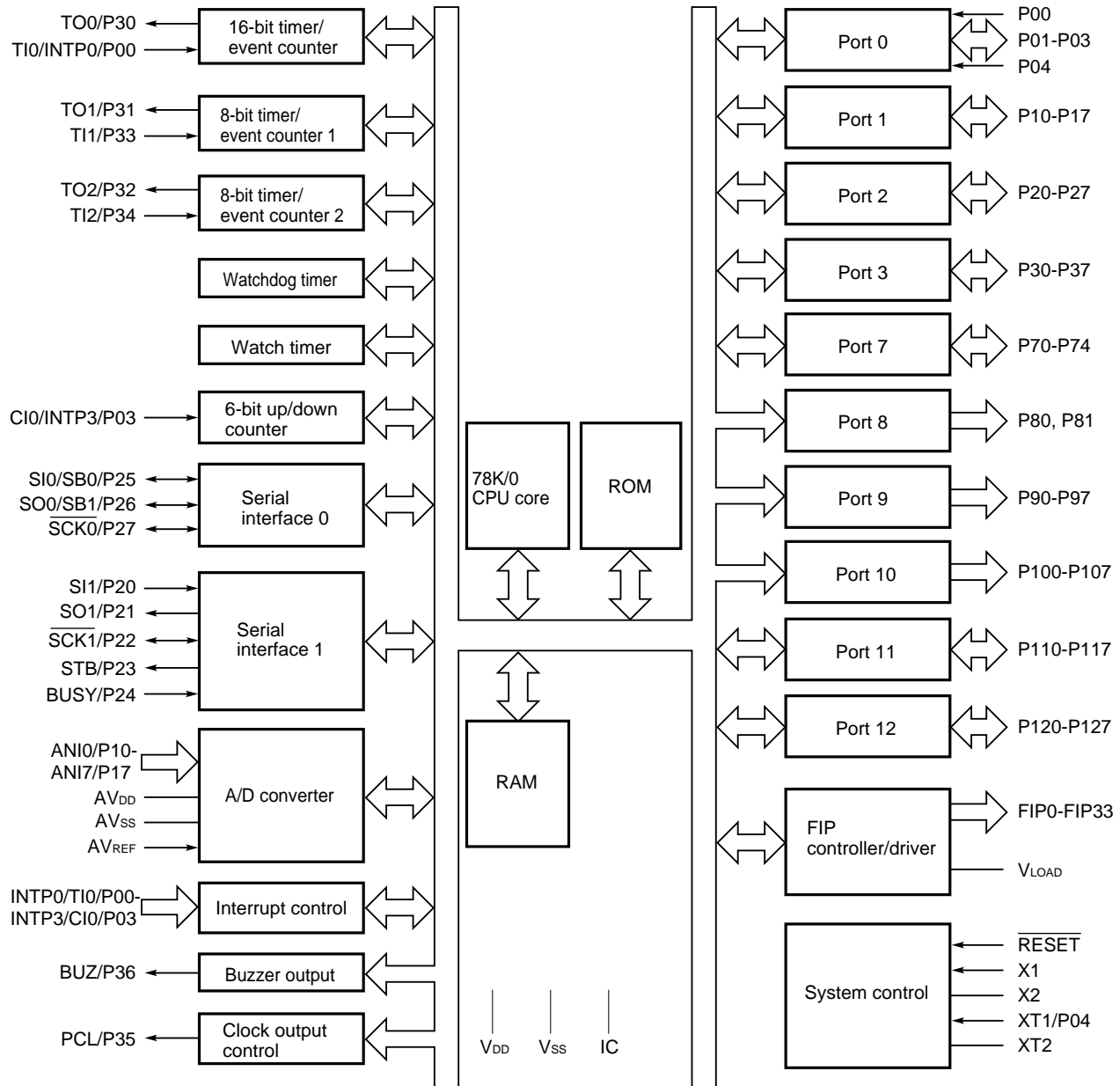

Remark The capacities of the internal ROM and RAM differ depending on the product.

3. PINS FUNCTIONS

3.1 PORT PINS (1/2)

Pin name	I/O	Function		On reset	Shared by:
P00	Input	Port 0	Input only	Input	INTP0/TI0
P01	I/O	5-bit I/O port	Can be specified for input or output in 1-bit units. When used as an input port pin, a built-in pull-up resistor can be used by software.	Input	INTP1
P02					INTP2
P03					INTP3/CI0
P04 ^{Note 1}	Input		Input only	Input	XT1
P10-P17	I/O	Port 1 8-bit I/O port Can be specified for input or output in 1-bit units. When used as an input port pin, a built-in pull-up resistor can be used by software. ^{Note 2}		Input	ANI0-ANI7
P20	I/O	Port 2 8-bit I/O port Can be specified for input or output in 1-bit units. When used as an input port pin, a built-in pull-up resistor can be used by software.		Input	SI1
P21					SO1
P22					SCK1
P23					STB
P24					BUSY
P25					SI0/SB0
P26					SO0/SB1
P27					SCK0
P30	I/O	Port 3 8-bit I/O port Can be specified for input or output in 1-bit units. Can directly drive LEDs. When used as an input port pin, a built-in pull-up resistor can be used by software. A pull-down resistor can be connected in 1-bit units by the mask option.		Input	TO0
P31					TO1
P32					TO2
P33					TI1
P34					TI2
P35					PCL
P36					BUZ
P37					—

- Notes**
- When the P04/XT1 pins is used as an input port pin, bit 6 (FRC) of the processor clock control register (PCC) must be set to 1. At this time, do not use the feedback resistor of the subsystem clock oscillator circuit.
 - When the P10/ANI0 through P17/ANI7 pins are used as the analog input lines of the A/D converter, be sure to place the port 1 in the input mode. In this case, the built-in pull-up resistors are automatically unused.

3.1 PORT PINS (2/2)

Pin name	I/O	Function	On reset	Shared by:
P70-P74	I/O	Port 7 5-bit N-ch open-drain I/O port Can be specified for input or output in 1-bit units. Can directly drive LEDs. A pull-up resistor can be connected in 1-bit units by the mask option.	Input	—
P80, P81	Output	Port 8 2-bit P-ch open-drain high-voltage output port. Can directly drive LEDs. A pull-down resistor can be connected in 1-bit units by the mask option (whether V_{LOAD} or V_{SS} is connected can be specified in bit units).	Output	FIP0, FIP1
P90-P97	Output	Port 9 8-bit P-ch open-drain high-voltage output port. Can directly drive LEDs. A pull-down resistor can be connected in 1-bit units by the mask option (whether V_{LOAD} or V_{SS} is connected can be specified in 4-bit units).	Output	FIP2-FIP9
P100-P107	Output	Port 10 8-bit P-ch open-drain high-voltage output port. Can directly drive LEDs. A pull-down resistor can be connected in 1-bit units by the mask option (whether V_{LOAD} or V_{SS} is connected can be specified in 4-bit units).	Output	FIP10-FIP17
P110-P117	I/O	Port 11 8-bit P-ch open-drain high-voltage I/O port. Can be specified for input or output in 1-bit units. Can directly drive LEDs. A pull-down resistor can be connected in 1-bit units by the mask option (whether V_{LOAD} or V_{SS} is connected can be specified in 4-bit units).	Input	FIP18-FIP25
P120-P127	I/O	Port 12 8-bit P-ch open-drain high-voltage I/O port Can be specified for input or output in 1-bit units. Can directly drive LEDs. A pull-down resistor can be connected in 1-bit units by the mask option (whether V_{LOAD} or V_{SS} is connected can be specified in 4-bit units).	Input	FIP26-FIP33

3.2 PINS OTHER THAN PORT PINS (1/2)

Pin name	I/O	Function	On reset	Shared by:
INTP0	Input	Valid edge (rising, falling, or both rising and falling edges) can be specified.	Input	P00/TI0
INTP1				P01
INTP2		External interrupt input		P02
INTP3		Falling edge-active external interrupt input	Input	P03/CI0
SI0	Input	Serial data input lines of serial interface	Input	P25/SB0
SI1				P20
SO0	Output	Serial data output lines of serial interface	Input	P26/SB1
SO1				P21
SB0	I/O	Serial data I/O lines of serial interface	Input	P25/SI0
SB1				P26/SO0
$\overline{\text{SCK0}}$	I/O	Serial clock I/O lines of serial interface	Input	P27
$\overline{\text{SCK1}}$				P22
STB	Output	Automatic transmission/reception strobe output line of serial interface	Input	P23
BUSY	Input	Automatic transmission/reception busy input line of serial interface	Input	P24
TI0	Input	External count clock input to 16-bit timer (TM0)	Input	P00/INTP0
TI1		External count clock input to 8-bit timer (TM1)		P33
TI2		External count clock input to 8-bit timer (TM2)		P34
TO0	Output	16-bit timer output (multiplexed with 14-bit PWM output)	Input	P30
TO1		8-bit timer output		P31
TO2				P32
CI0	Input	Clock input to 6-bit up/down counter	Input	P03/INTP3
PCL	Output	Clock output (for trimming main system clock and subsystem clock)	Input	P35
BUZ	Output	Buzzer output	Input	P36
FIP0, FIP1	Output	High-voltage, high-current digit/segment output of FIP controller/driver	Output	P80, P81
FIP2-FIP9				P90-P97
FIP10-FIP15	Output	High-voltage, high-current digit/segment output of FIP controller/driver	Output	P100-P105
FIP16, FIP17	Output	High-voltage segment output of FIP controller/driver	Output	P106, P107
FIP18-FIP25			Input	P110-P117
FIP26-FIP33			Input	P120-P127
V _{LOAD}	—	Connects pull-down resistor to FIP controller/driver	—	—

3.2 PINS OTHER THAN PORT PINS (2/2)

Pin name	I/O	Function	On reset	Shared by:
ANI0-ANI7	Input	A/D converter analog input lines	Input	P10-P17
AV _{REF}	Input	A/D converter reference voltage input line	—	—
AV _{DD}	—	Analog power supply to A/D converter. Connected to the V _{DD} pin.	—	—
AV _{SS}	—	A/D converter ground line. Connected to the V _{SS} pin.	—	—
$\overline{\text{RESET}}$	Input	System reset input	—	—
X1	Input	Connect crystal for main system clock oscillation	—	—
X2	—		—	—
XT1	Input	Connect crystal for subsystem clock oscillation	Input	P04
XT2	—		—	—
V _{DD}	—	Positive power supply	—	—
V _{SS}	—	Ground potential	—	—
IC	—	Internal connection. Connected directly to the V _{SS} pin.	—	—

3.3 PIN I/O CIRCUITS AND PROCESSING OF UNUSED PINS

Table 3-1 shows the I/O circuit type of each pin and the processing of unused pins.

For the configuration of the I/O circuit of each type, refer to Fig. 3-1.

Table 3-1 I/O Circuit Type

Pin name	I/O Circuit type	I/O	Recommended connections when unused
P00/INTP0/TI0	2	Input	Connected to V _{SS} .
P01/INTP1	8-A	I/O	Individually connected to V _{SS} with a resistor.
P02/INTP2			
P03/INTP3/CI0			
P04/XT1	16	Input	Connected to V _{DD} or V _{SS} .
P10/ANI0-P17/ANI7	11	I/O	Individually connected to V _{DD} or V _{SS} with a resistor.
P20/SI1	8-A		
P21/SO1	5-A		
P22/ $\overline{\text{SCK}}1$	8-A		
P23/STB	5-A		
P24/BUSY	8-A		
P25/SI0/SB0	10-A		
P26/SO0/SB1			
P27/ $\overline{\text{SCK}}0$			
P30/TO0	5-C		
P31/TO1			
P32/TO2			
P33/TI1	8-B		
P34/TI2			
P35/PCL	5-C		
P36/BUZ			
P37			
P70-P74			
P80/FIP0, P81/FIP1	14-A		
P90/FIP2-P97/FIP9			
P100/FIP10-P107/FIP17			
P110/FIP18-P117/FIP25	15-C	I/O	Individually connected to V _{DD} or V _{SS} with a resistor.
P120/FIP26-P127/FIP33			
$\overline{\text{RESET}}$	2	Input	—
XT2	16	—	Open
AV _{REF}	—		Connected to V _{SS} .
AV _{DD}			Connected to V _{DD} .
AV _{SS}			Connected to V _{SS} .
V _{LOAD}			
IC			Connected directly to V _{SS} .

Fig. 3-1 Pin I/O Circuits (1/2)

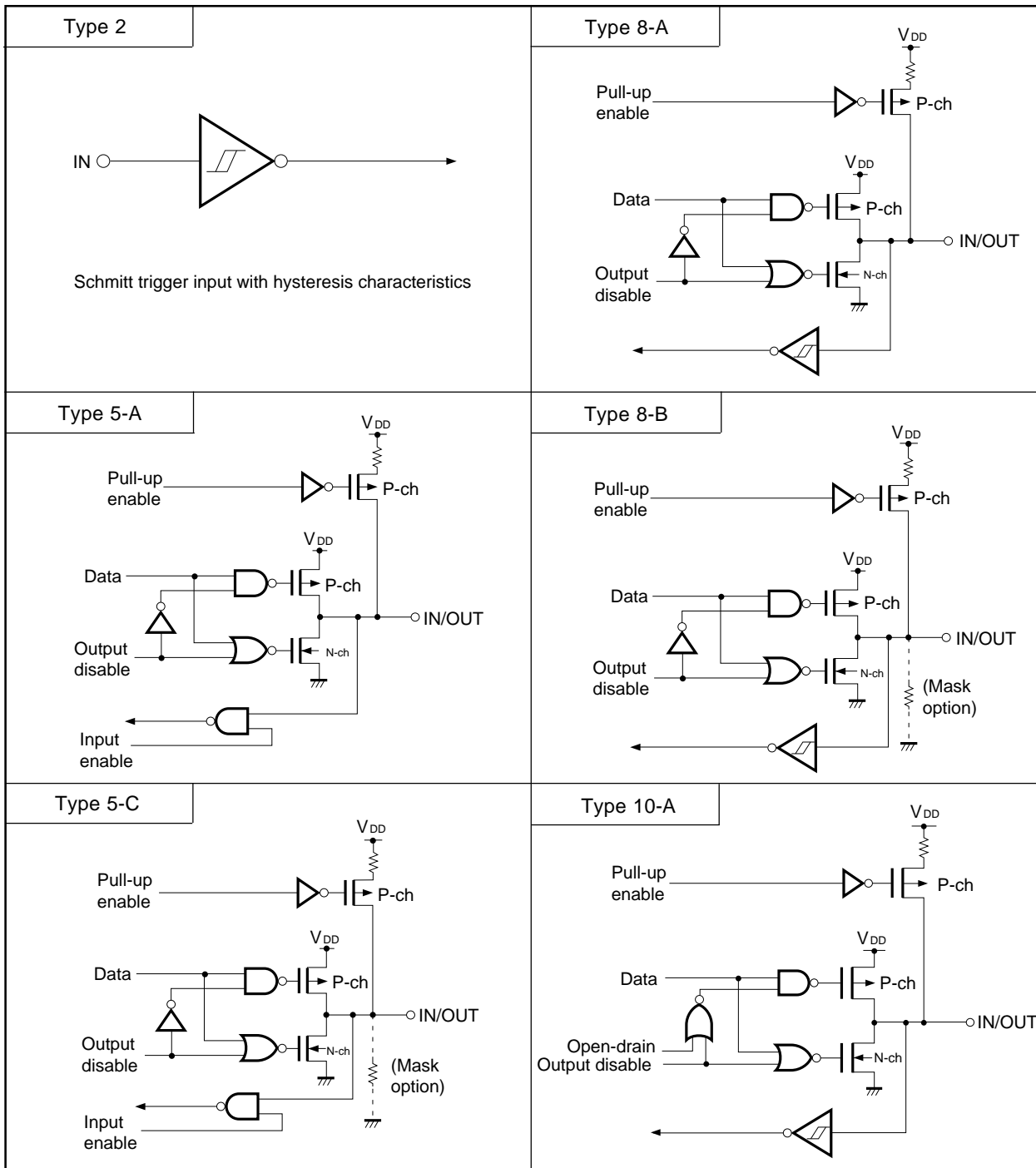
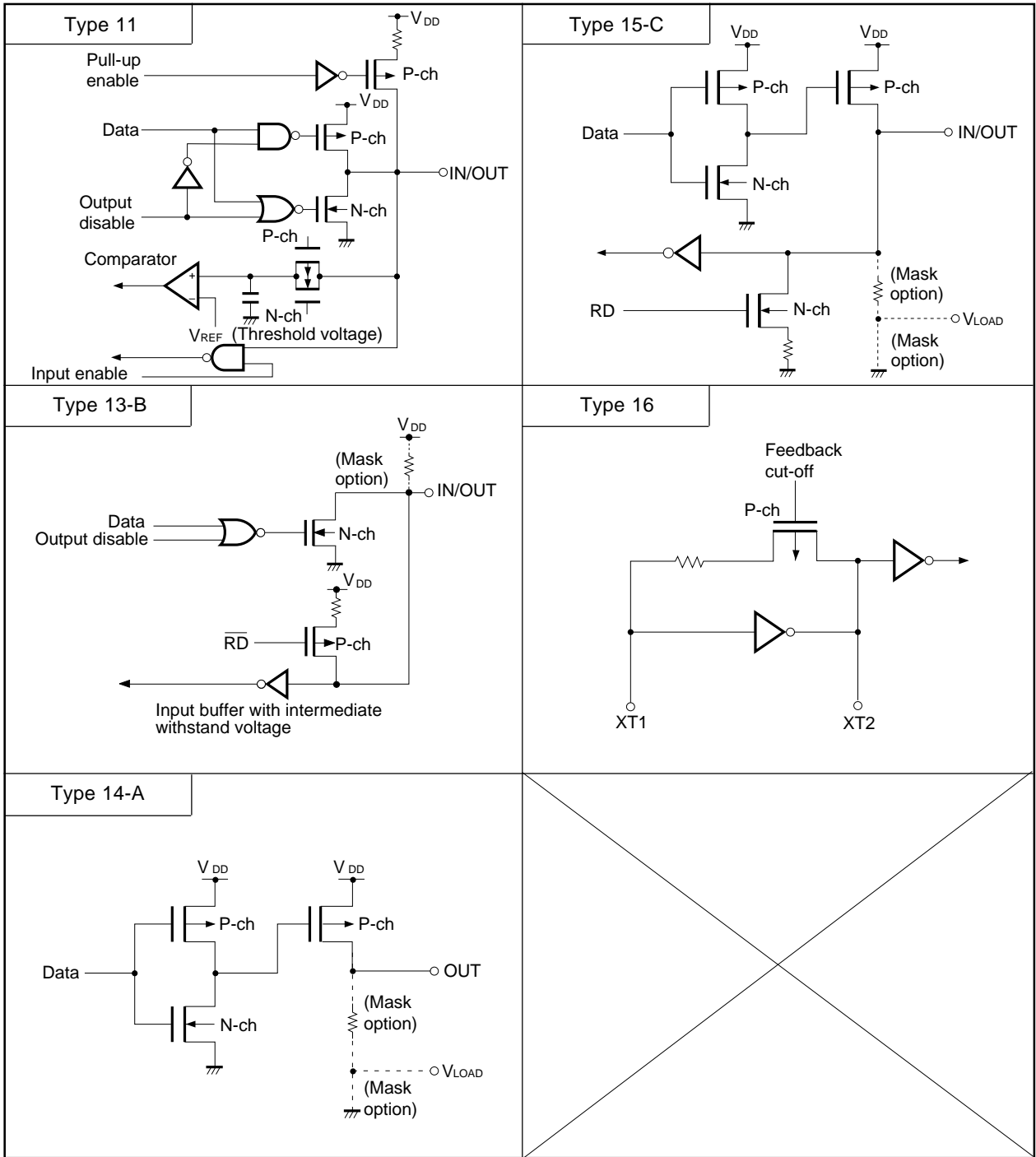

Fig. 3-1 Pin I/O Circuits (2/2)



4. MEMORY SPACE

Fig. 4-1 shows the memory map for μPD78042F, μPD78043F, μPD78044F, and μPD78045F.

Fig. 4-1 Memory Map

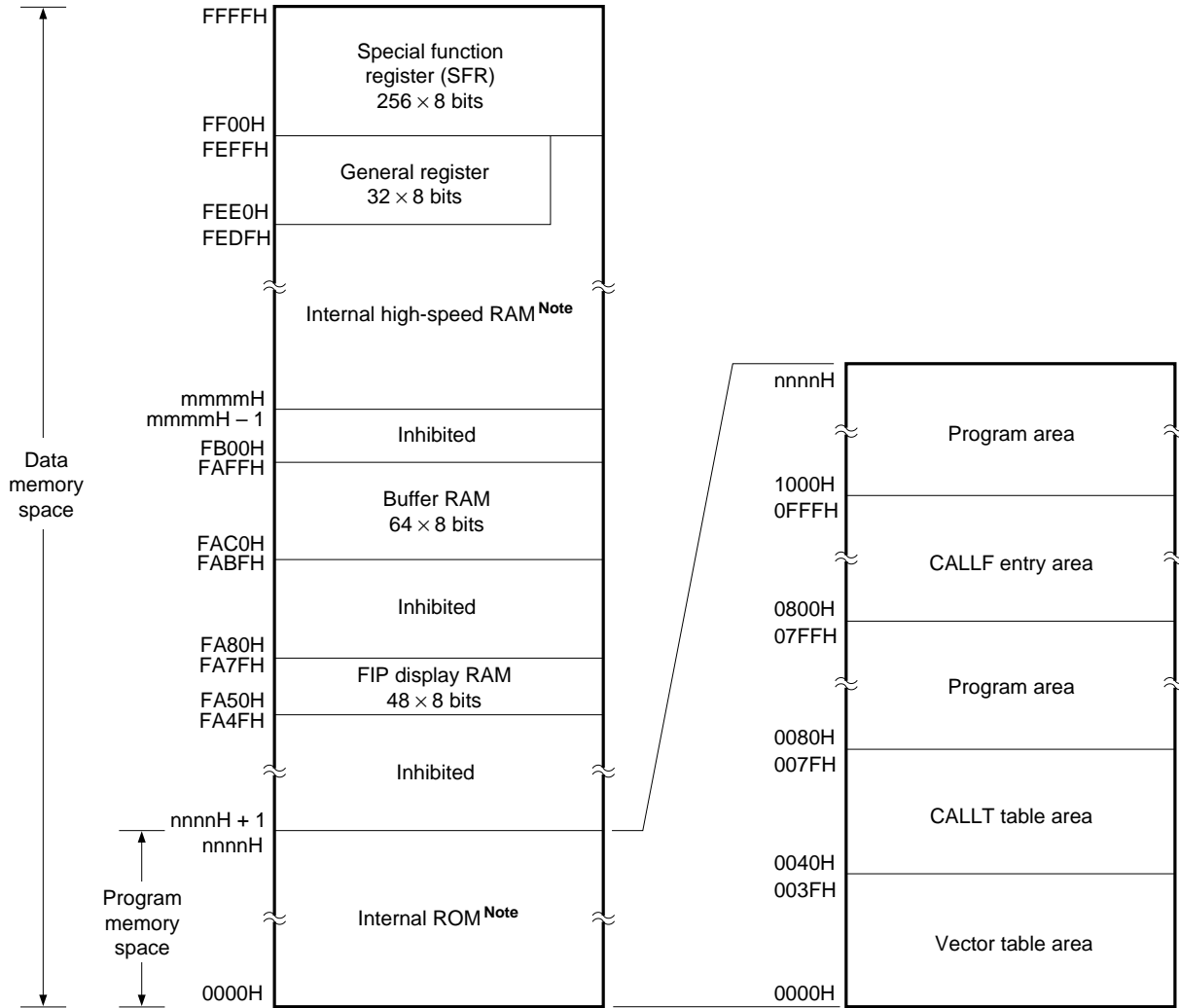

Note The internal ROM and internal high-speed RAM capacities vary depending on the product. (See the table below.)

Product name	Last Address of Internal ROM nnnnH	First address of internal high-speed RAM mmmmH
μPD78042F	3FFFH	FD00H
μPD78043F	5FFFH	
μPD78044F	7FFFH	FB00H
μPD78045F	9FFFH	

5. PERIPHERAL HARDWARE FUNCTIONS

5.1 PORTS

I/O ports are classified into the following five types:

• CMOS input (P00, P04)	: 2
• CMOS input/output (P01 - P03, ports 1 - 3)	: 27
• N-ch open-drain input/output (port 7)	: 5
• P-ch open-drain output (ports 8 - 10)	: 18
• P-ch open-drain input/output (ports 11 and 12)	: 16
<hr/>	
Total	: 68

Table 5-1 Port Function

Product	Pin	Function
Port 0	P00, P04	Input-only port
	P01-P03	I/O port. Can be specified for input or output in 1-bit units. When used as input port, internal pull-up resistor can be connected through software.
Port 1	P10-P17	I/O port. Can be specified for input or output in 1-bit units. When used as input port, internal pull-up resistor can be connected through software.
Port 2	P20-P27	I/O port. Can be specified for input or output in 1-bit units. When used as input port, internal pull-up resistor can be connected through software.
Port 3	P30-P37	I/O port. Can be specified for input or output in 1-bit units. When used as input port, internal pull-up resistor can be connected through software. Pull-down resistor can be connected in 1-bit units by the mask option. Can directly drive LED.
Port 7	P70-P74	N-ch open-drain I/O port. Can be specified for input or output in 1-bit units. Pull-up resistor can be connected in 1-bit units by the mask option. Can directly drive LED.
Port 8	P80, P81	P-ch open-drain output port with high withstand voltage. Pull-down resistor can be connected in 2-bit units by the mask option (connection to V_{LOAD} or V_{SS} can be specified in 2-bit units). Can directly drive LED.
Port 9	P90-P97	P-ch open-drain output port with high withstand voltage. Pull-down resistor can be connected in 1-bit units by the mask option (connection to V_{LOAD} or V_{SS} can be specified in 4-bit units). Can directly drive LED.
Port 10	P100-P107	P-ch open-drain output port with high withstand voltage. Pull-down resistor can be connected in 1-bit units by the mask option (connection to V_{LOAD} or V_{SS} can be specified in 4-bit units). Can directly drive LED.
Port 11	P110-P117	P-ch open-drain I/O port with high withstand voltage. Can be specified for input or output in 1-bit units. Pull-down resistor can be connected in 1-bit units by the mask option (connection to V_{LOAD} or V_{SS} can be specified in 4-bit units). Can directly drive LED.
Port 12	P120-P127	P-ch open-drain I/O port with high withstand voltage. Can be specified for input or output in 1-bit units. Pull-down resistor can be connected in 1-bit units by the mask option (connection to V_{LOAD} or V_{SS} can be specified in 4-bit units). Can directly drive LED.

5.2 CLOCK GENERATOR CIRCUIT

The clock generator circuit has two kinds of generator circuits: the main system clock and subsystem clock.

The instruction time can be changed.

- 0.4 μs/0.8 μs/1.6 μs/3.2 μs/6.4 μs (with main system clock: 5.0 MHz)
- 122 μs (with subsystem clock: 32.768 kHz)

Fig. 5-1 Clock Generator Circuit Block Diagram

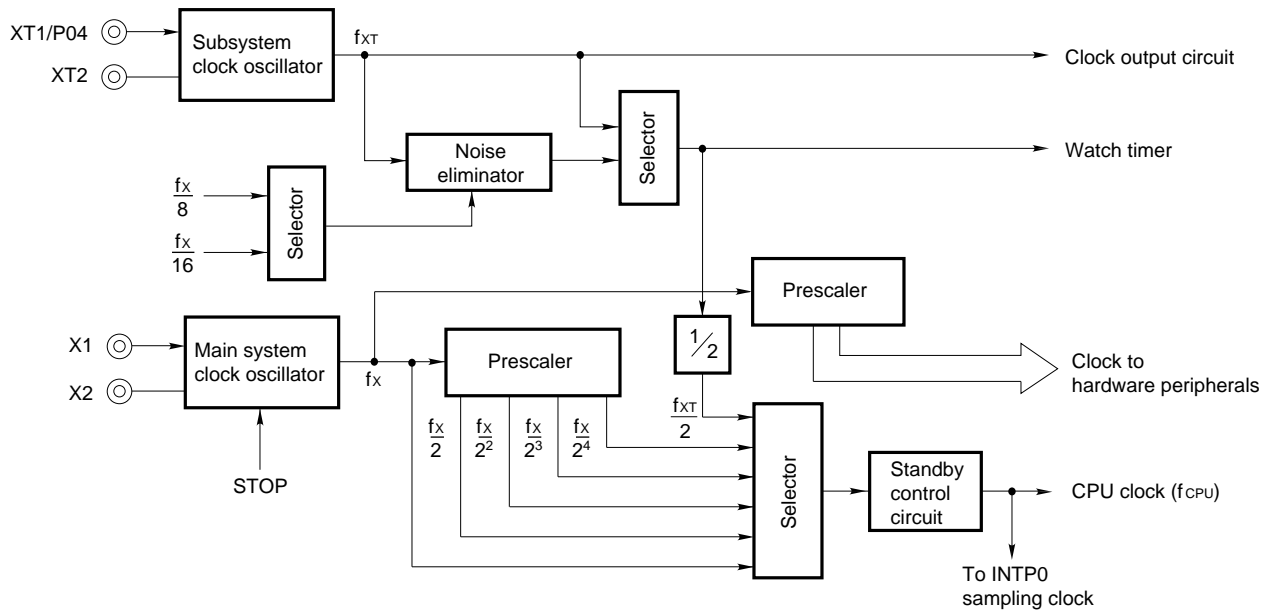

5.3 TIMER/EVENT COUNTER

Six channels of timer/event counters are provided.

- 16-bit timer/event counter : 1 channel
- 8-bit timer/event counter : 2 channels
- Watch timer : 1 channel
- Watchdog timer : 1 channel
- 6-bit up/down counter : 1 channel

Table 5-2 Timer/Event Counter Groups and Configurations

		16-bit timer/ event counter	8-bit timer/ event counter	Watch timer	Watchdog timer	6-bit up/ down counter
Group	Interval timer	1 channel	2 channels	1 channel	1 channel	—
	External event counter	1 channel	2 channels	—	—	1 channel
Function	Timer output	1 output	2 outputs	—	—	—
	PWM output	1 output	—	—	—	—
	Pulse width measurement	1 input	—	—	—	—
	Square wave output	1 output	2 outputs	—	—	—
	Interrupt Request	1	2	1	1	1
	Test input	—	—	1 input	—	—

Fig. 5-2 16-Bit Timer/Event Counter Block Diagram

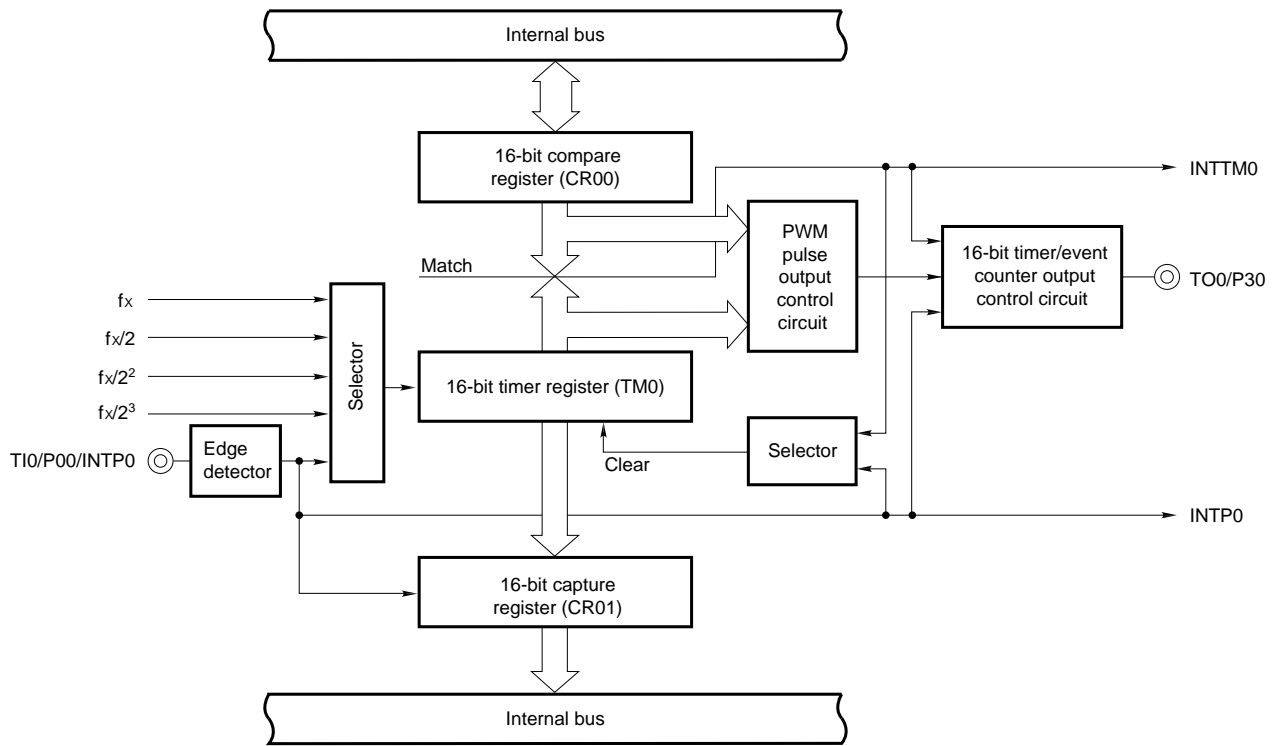

Fig. 5-3 8-Bit Timer/Event Counter Block Diagram

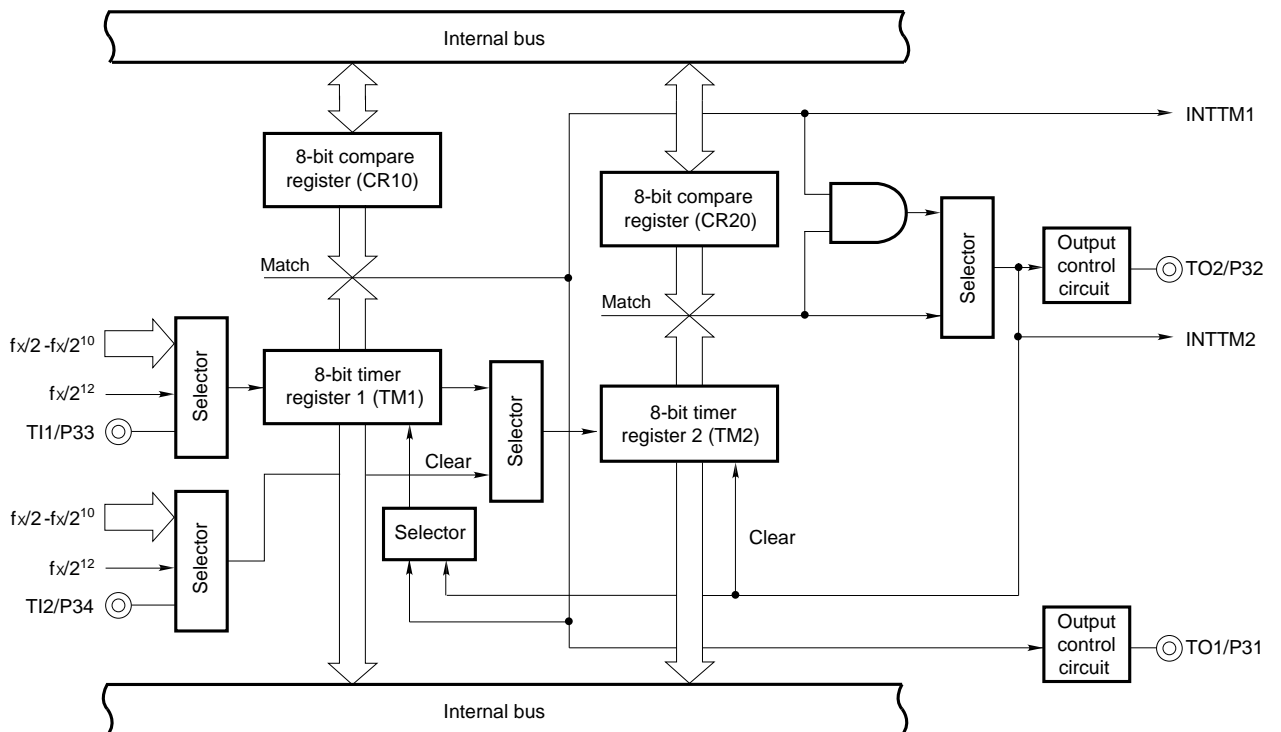

Fig. 5-4 Watch Timer Block Diagram

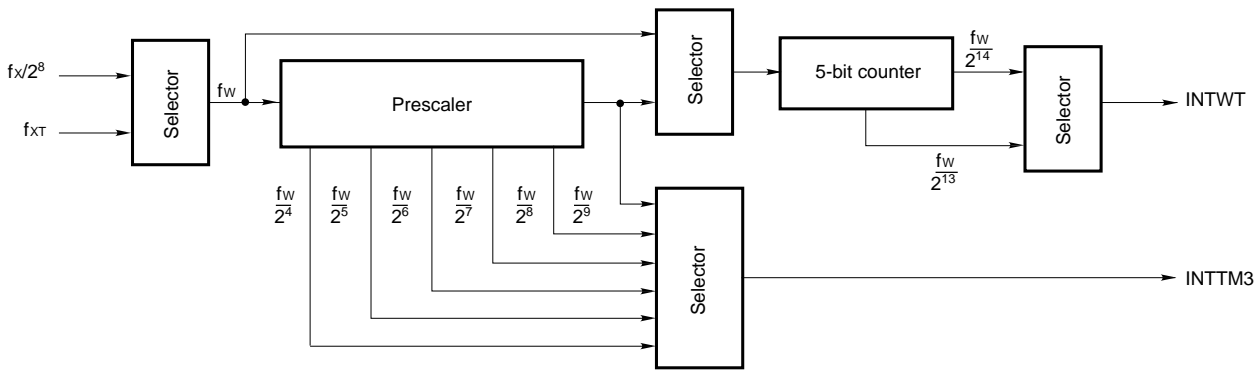

Fig. 5-5 Watchdog Timer Block Diagram

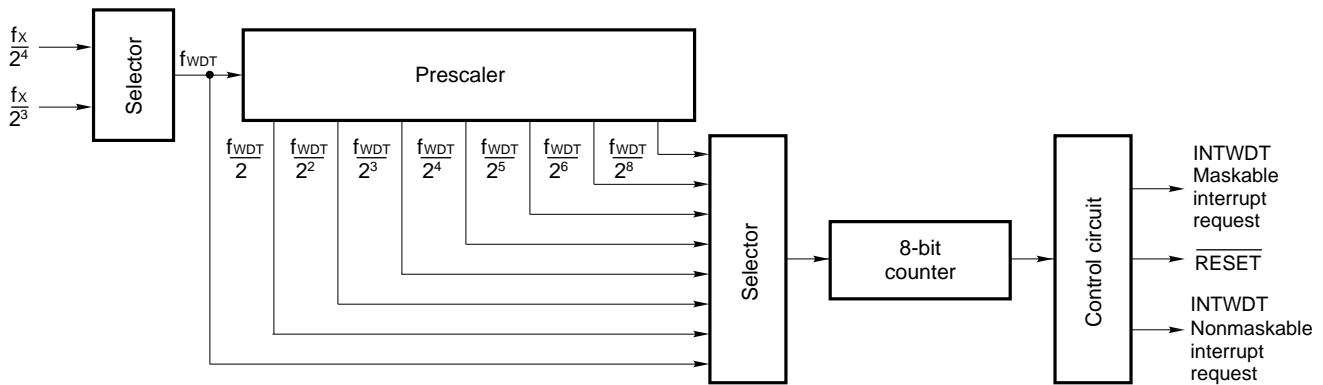
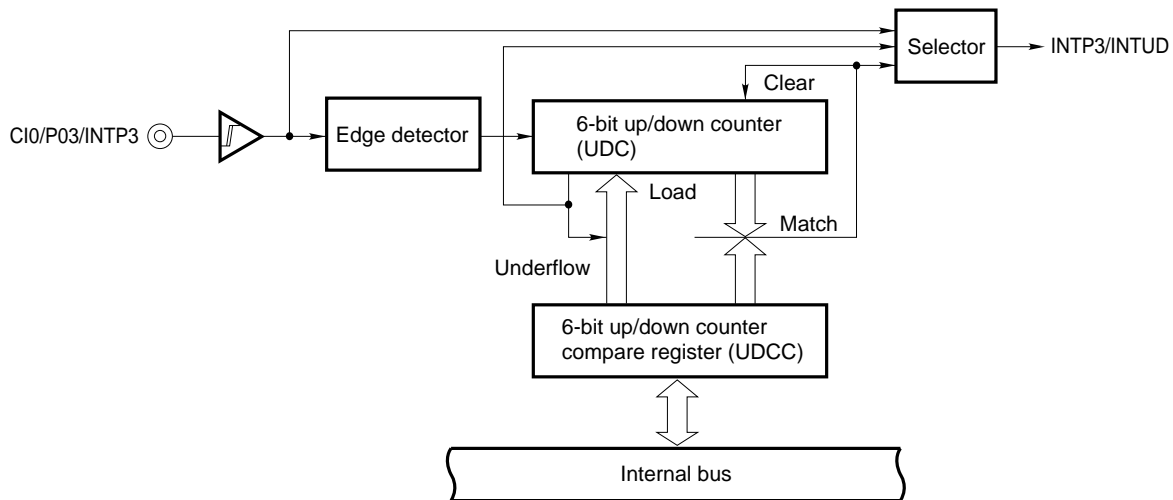

Fig. 5-6 6-Bit Up/Down Counter Block Diagram



Caution When using the 6-bit up/down counter, set the CI0/P03/INTP3 pin in the input mode (set bit 3 of port mode register 0 (PM03) to 1).

5.4 CLOCK OUTPUT CONTROL CIRCUIT

Clocks of the following frequencies can be output to the clock:

- 19.5 kHz/39.1 kHz/78.1 kHz/156 kHz/313 kHz/625 kHz (with main system clock: 5.0 MHz)
- 32.768 kHz (with subsystem clock: 32.768 kHz)

Fig. 5-7 Clock Output Control Circuit Block Diagram

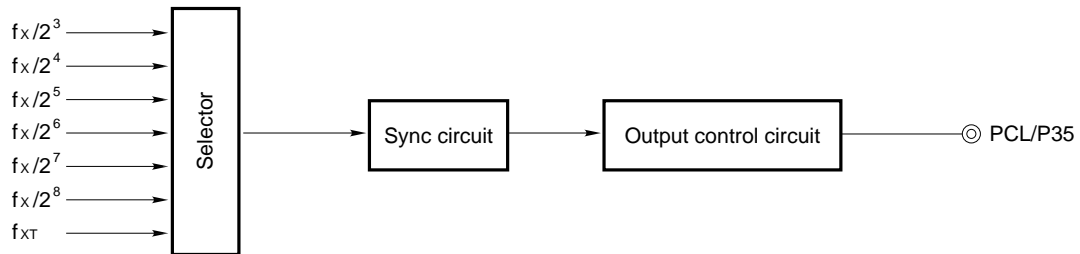

5.5 BUZZER OUTPUT CONTROL CIRCUIT

Clocks of the following frequencies can be output to the buzzer:

- 1.2 kHz/2.4 kHz/4.9 kHz (with main system clock: 5.0 MHz)

Fig. 5-8 Buzzer Output Control Circuit Block Diagram

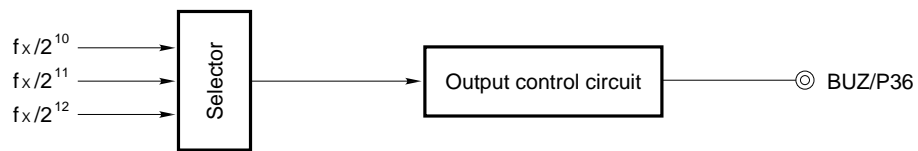

5.6 A/D CONVERTER

An 8-bit resolution 8-channel A/D converter is provided.
 This A/D converter can be started in the following two modes:

- Hardware start
- Software start

Fig. 5-9 A/D Converter Block Diagram

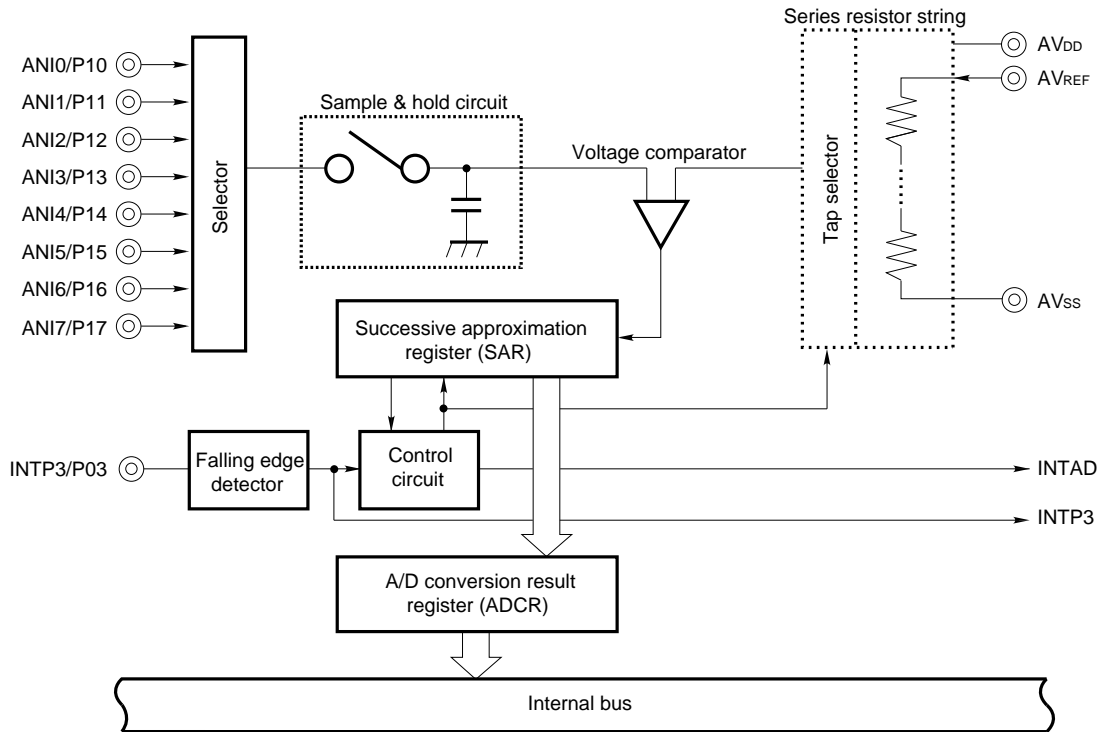

5.7 SERIAL INTERFACE

Two channels of clocked serial interfaces are provided.

- Serial interface channel 0
- Serial interface channel 1

Table 5-3 Serial Interface Groups and Functions

Function	Serial interface channel 0	Serial interface channel 1
3-wire serial I/O mode	• (MSB/LSB first selectable)	• (MSB/LSB first selectable)
SBI (serial bus interface) mode	• (MSB first)	—
2-wire serial I/O mode	• (MSB first)	—
3-wire serial I/O mode with automatic transmission/reception function	—	• (MSB/LSB first selectable)

Fig. 5-10 Serial Interface Channel 0 Block Diagram

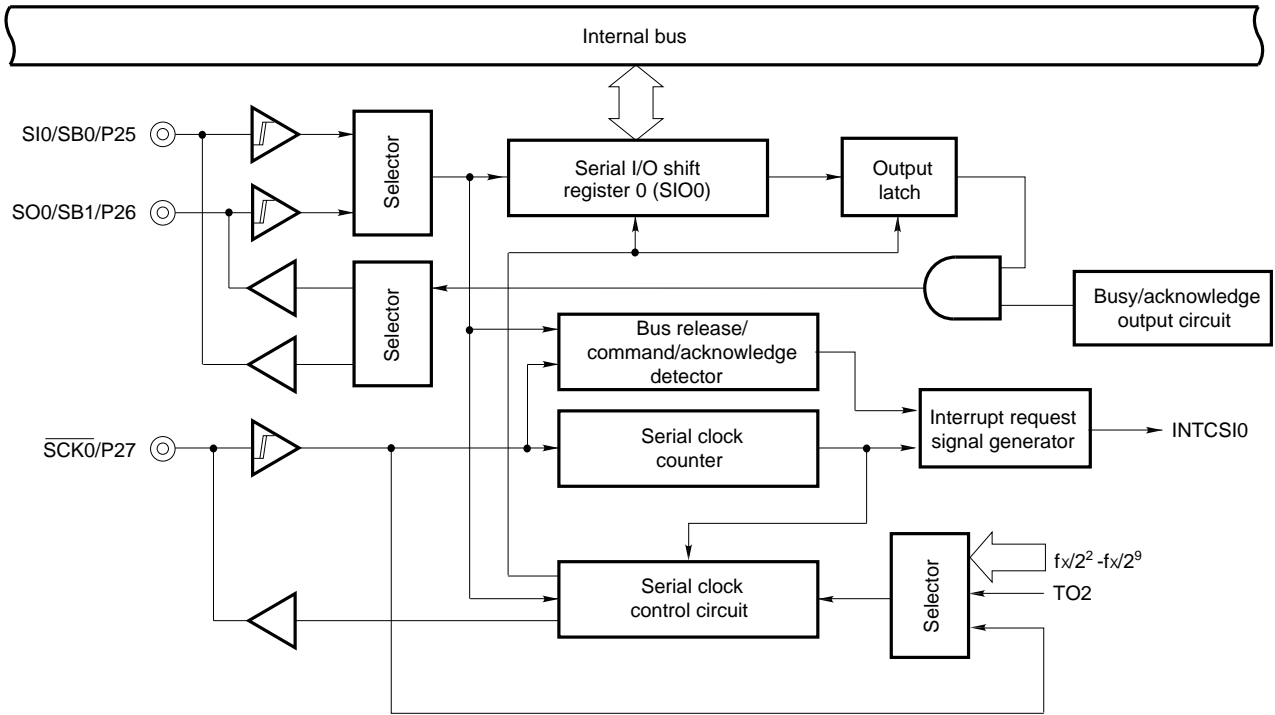
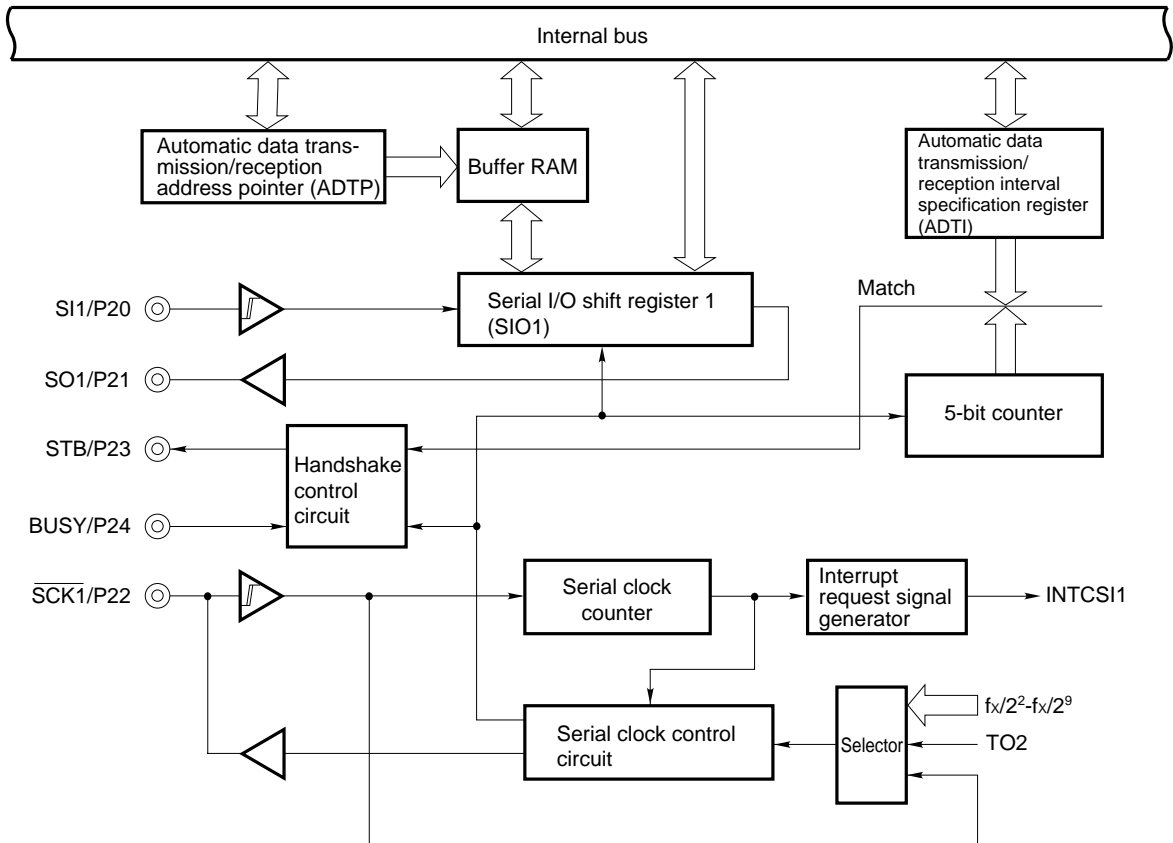

Fig. 5-11 Serial Interface Channel 1 Block Diagram



5.8 FIP CONTROLLER/DRIVER

An FIP controller/driver having the following features is provided:

- (a) Automatic output of segment signals (DMA operation) and digit signals by automatically reading display data
- (b) Display mode registers (DSPM0 and DSPM1) that can control an FIP of 9 to 24 segments and 2 to 16 digits
- (c) Port pins not used for FIP display can be used as output port or I/O port pins.
- (d) Display mode register (DSPM1) can adjust luminance in eight steps.
- (e) Hardware suitable for key scan application using segment pins
- (f) High-voltage output buffer (FIP driver) that can directly drive an FIP
- (g) Display output pins can be connected to a pull-down resistor by the mask option.

Fig. 5-12 Selecting Display Modes

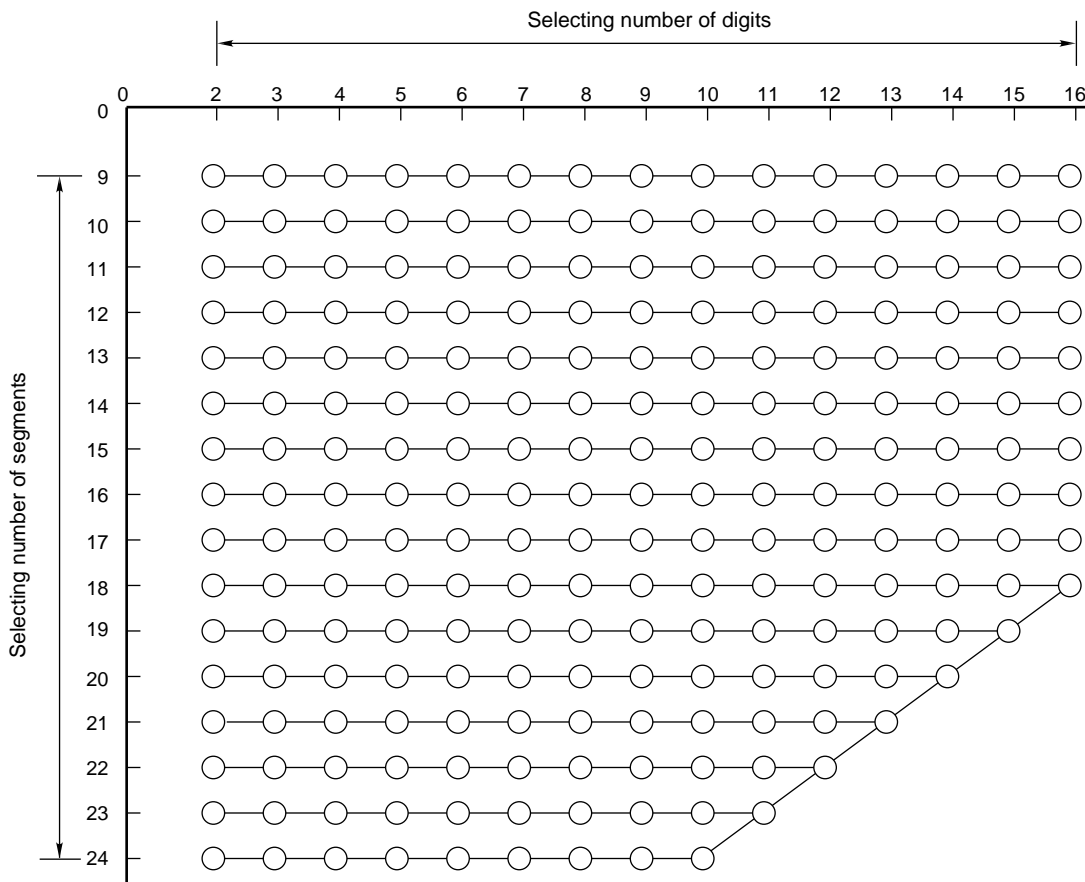

Caution If the total number of digits and segments exceeds 34, the specified number of digits takes precedence.

6. INTERRUPT FUNCTION AND TEST FUNCTION

6.1 INTERRUPT FUNCTION

The following three types of interrupt functions are available:

- Non-maskable interrupt : 1
- Maskable interrupt : 13
- Software interrupt : 1

Table 6-1 Interrupt Source List

Interrupt type	Note 1 Default priority	Interrupt source		Internal/external	Vector table address	Note 2 Basic configuration type	
		Name	Trigger				
Non-maskable	—	INTWDT	Watchdog timer overflow (with watchdog timer mode 1 selected)	Internal	0004H	(A)	
Maskable	0	INTWDT	Watchdog timer overflow (with interval timer mode selected)			External	0006H 0008H 000AH 000CH
	1	INTP0	Pin input edge detection	(C)			
	2	INTP1					
	3	INTP2					
	4	INTP3					
			INTUD	6-bit up/down counter match signal generation	Internal	000EH 0010H 0012H 0014H 0016H 0018H 001AH 001CH	(B)
	5	INTCSI0	End of serial interface channel 0 transfer				
	6	INTCSI1	End of serial interface channel 1 transfer				
	7	INTTM3	Reference time interval signal from watch timer				
	8	INTTM0	16-bit timer/event counter match signal generation				
	9	INTTM1	8-bit timer/event counter 1 match signal generation				
	10	INTTM2	8-bit timer/event counter 2 match signal generation				
	11	INTAD	End of A/D converter conversion				
12	INTKS	Key scan timing from FIP controller/driver					
Software	—	BRK	Execution of BRK instruction	—			

Notes 1. Default priority is the priority order when several maskable interrupts are generated at the same time. 0 is the highest order and the 12 is the lowest order.

2. Basic configuration types (A) to (E) correspond to (A) to (E) in Fig. 6-1.

Fig. 6-1 Basic Configuration of Interrupt Function (1/2)

(A) Internal non-maskable interrupt

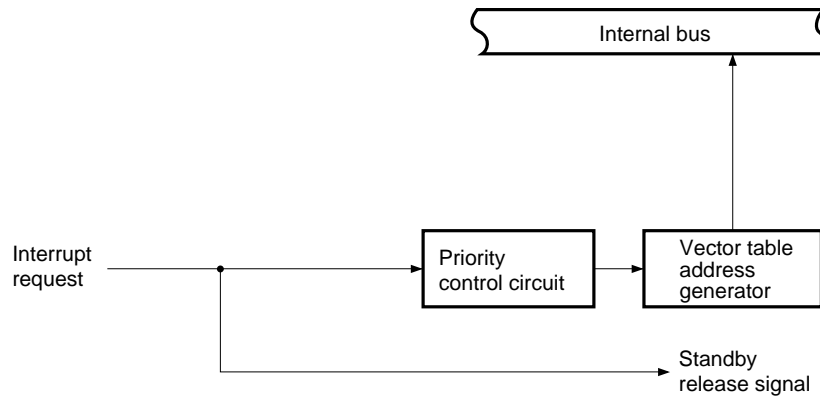

(B) Internal maskable interrupt

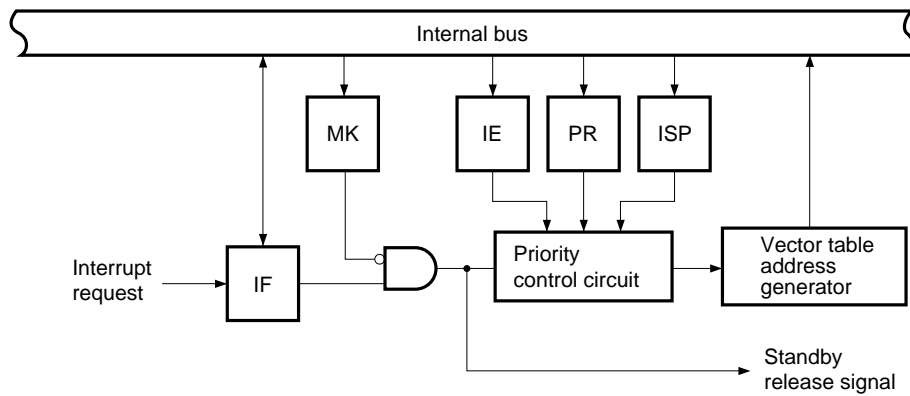

(C) External maskable interrupt (INTP0)

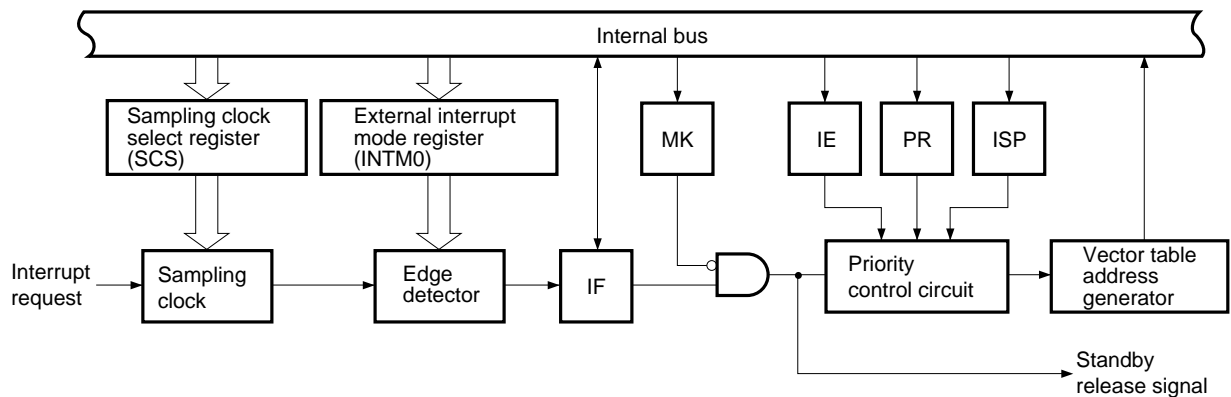
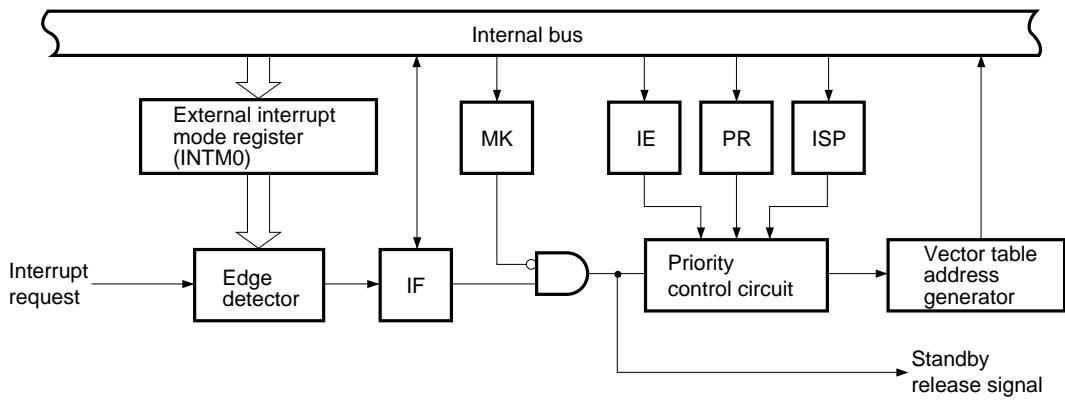
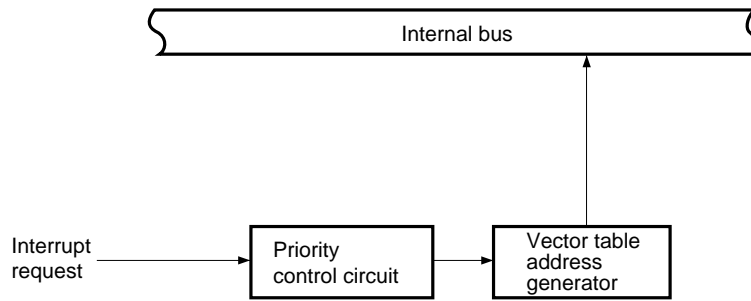

Fig. 6-1 Basic Configuration of Interrupt Function (2/2)

(D) External maskable interrupt (except INTP0)



(E) Software interrupt



- IF : Interrupt request flag
- IE : Interrupt enable flag
- ISP : In-service priority flag
- MK : Interrupt mask flag
- PR : Priority specification flag

6.2 TEST FUNCTION

The following test function is available.

Test input source		Internal/external
Name	Trigger	
INTWT	Overflow of watch timer	Internal

Fig. 6-2 Basic Configuration of Test Function

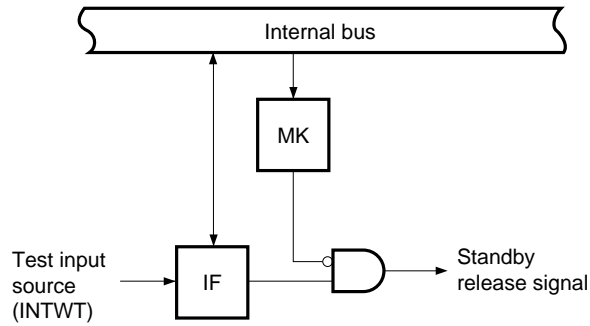

IF : Test request flag

MK : Test mask flag

7. STANDBY FUNCTION

The standby function is to reduce the current dissipation of the system and can be effected in the following two modes:

- HALT mode : In this mode, the operating clock of the CPU is stopped. By using this mode in combination with the normal operation mode, the system can be operated intermittently, so that the average current dissipation can be reduced.
- STOP mode : Oscillation of the main system clock is stopped. All the operations on the main system clock are stopped, and therefore, the current dissipation of the system can be minimized with only the subsystem clock oscillating.

Fig. 7-1 Standby Function

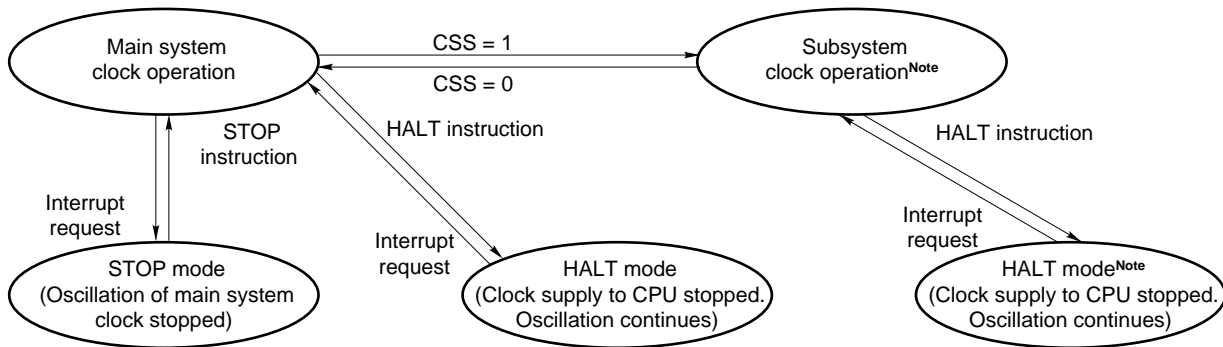

Note By stopping the main system clock, the current dissipation can be reduced. When the CPU operates on the subsystem clock, stop the main system clock by setting bit 7 (MCC) of the processor clock control register (PCC). The STOP instruction cannot be used.

Caution When the main system clock is stopped and the subsystem clock is operating, to switch again from the subsystem clock to the main system clock, allow sufficient time for the oscillation to settle before switching, by coding the program accordingly.

8. RESET FUNCTION

The system can be reset in the following two modes:

- External reset by $\overline{\text{RESET}}$ pin
- Internal reset by watchdog timer that detects hang up

9. INSTRUCTION SET

(1) 8-bit instruction

MOV, XCH, ADD, ADDC, SUB, SUBC, AND, OR, XOR, CMP, MULU, DIVUW, INC, DEC, ROR, ROL, RORC, ROLC, ROR4, ROL4, PUSH, POP, DBNZ

Second operand First operand	#byte	A	r Note	sfr	saddr	!addr16	PSW	[DE]	[HL]	[HL + byte] [HL + B] [HL + C]	\$addr16	1	None
A	ADD ADDC SUB SUBC AND OR XOR CMP		MOV XCH ADD ADDC SUB SUBC AND OR XOR CMP	MOV XCH	MOV XCH ADD ADDC SUB SUBC AND OR XOR CMP	MOV XCH ADD ADDC SUB SUBC AND OR XOR CMP	MOV	MOV XCH	MOV XCH ADD ADDC SUB SUBC AND OR XOR CMP	MOV XCH ADD ADDC SUB SUBC AND OR XOR CMP		ROR ROL RORC ROLC	
r	MOV	MOV ADD ADDC SUB SUBC AND OR XOR CMP											INC DEC
B, C											DBNZ		
sfr	MOV	MOV											
saddr	MOV ADD ADDC SUB SUBC AND OR XOR CMP	MOV									DBNZ		INC DEC
!addr16		MOV											
PSW	MOV	MOV											PUSH POP
[DE]		MOV											
[HL]		MOV											ROR4 ROL4
[HL + byte] [HL + B] [HL + C]		MOV											
X													MULU
C													DIVUW



Note Except for r = A

(2) 16-bit instruction

MOVW, XCHW, ADDW, SUBW, CMPW, PUSH, POP, INCW, DECW

Second operand / First operand	#word	AX	rp ^{Note}	sfrp	saddrp	!addr16	SP	None
AX	ADDW SUBW CMPW		MOVW XCHW	MOVW	MOVW	MOVW	MOVW	
rp	MOVW	MOVW ^{Note}						INCW DECW PUSH POP
sfrp	MOVW	MOVW						
saddrp	MOVW	MOVW						
!addr16		MOVW						
SP	MOVW	MOVW						

Note Only when rp = BC, DE, HL

(3) Bit manipulation instruction

MOV1, AND1, OR1, XOR1, SET1, CLR1, NOT1, BT, BF, BTCLR

Second operand / First operand	A.bit	sfr.bit	saddr.bit	PSW.bit	[HL].bit	CY	\$addr16	None
A.bit						MOV1	BT BF BTCLR	SET1 CLR1
sfr.bit						MOV1	BT BF BTCLR	SET1 CLR1
saddr.bit						MOV1	BT BF BTCLR	SET1 CLR1
PSW.bit						MOV1	BT BF BTCLR	SET1 CLR1
[HL].bit						MOV1	BT BF BTCLR	SET1 CLR1
CY	MOV1 AND1 OR1 XOR1	MOV1 AND1 OR1 XOR1	MOV1 AND1 OR1 XOR1	MOV1 AND1 OR1 XOR1	MOV1 AND1 OR1 XOR1			SET1 CLR1 NOT1

(4) Call/Branch instruction

CALL, CALLF, CALLT, BR, BC, BNC, BZ, BNZ, BT, BF, BTCLR, DBNZ

Second operand First operand	AX	!addr16	!addr11	[addr5]	\$addr16
Basic operation	BR	CALL BR	CALLF	CALLT	BR BC BNC BZ BNZ
Compound operation					BT BF BTCLR DBNZ

(5) Other instructions

ADJBA, ADJBS, BRK, RET, RETI, RETB, SEL, NOP, EI, DI, HALT, STOP

★ 10. ELECTRICAL SPECIFICATIONS

ABSOLUTE MAXIMUM RATINGS (T_A = 25 °C)

Parameter	Symbol	Conditions		Rating	Unit
Power supply voltage	V _{DD}			-0.3 to +7.0	V
	V _{LOAD}			V _{DD} - 40 to V _{DD} + 0.3	V
	AV _{DD}			-0.3 to V _{DD} + 0.3	V
	AV _{REF}			-0.3 to V _{DD} + 0.3	V
	AV _{SS}			-0.3 to +0.3	V
Input voltage	V _{I1}	P00-P04, P10-P17 (except when used as analog input pins), P20-P27, P30-P37, X1, X2, XT2, RESET		-0.3 to V _{DD} + 0.3	V
	V _{I2}	P70-P74	N-ch open drain	-0.3 to +16 ^{Note 1}	V
	V _{I3}	P110-P117, P120-P127	P-ch open drain	V _{DD} - 40 to V _{DD} + 0.3	V
Output voltage	V _{O1}	P01-P03, P10-P17, P20-P27, P30-P37		-0.3 to V _{DD} + 0.3	V
	V _{O2}	P70-P74		-0.3 to +16 ^{Note 1}	V
	V _{O3}	P80, P81, P90-P97, P100-P107, P110-P117, P120-P127		V _{DD} - 40 to V _{DD} + 0.3	V
Analog input voltage	V _{AN}	ANI0-ANI7	Analog input pin	AV _{SS} - 0.3 to AV _{REF} + 0.3	V
Output current, high	I _{OH}	P01-P03, P10-P17, P20-P27, P30-P37 per pin		-10	mA
		P01-P03, P10-P17, P20-P27, P30-P37 total		-30	mA
		P80, P81, P90-P97, P100-P107, P110-P117, P120-P127 per pin		-30	mA
		P80, P81, P90-P97, P100-P107, P110-P117, P120-P127 total		-120	mA
Output current, low	I _{OL}	P01-P03, P10-P17, P20-P27, P30-P37, P70-P74 per pin	Peak value	30	mA
			rms value	15 ^{Note 2}	mA
		P70-P74 total	Peak value	100	mA
			rms value	60 ^{Note 2}	mA
		P01-P03, P10-P17, P20-P27, P30-P37 total	Peak value	50	mA
			rms value	20 ^{Note 2}	mA
Total power dissipation	P _T ^{Note 3}	T _A = -40 to +60 °C		800	mW
		T _A = +85 °C		600	mW
Operating ambient temperature	T _A			-40 to +85	°C
Storage temperature	T _{stg}			-65 to +150	°C

Caution Exposure to Absolute Maximum Ratings for extended periods may affect device reliability; exceeding the ratings could cause permanent damage. The parameters apply independently. The device should be operated within the limits specified under DC and AC Characteristics.

Remark Unless otherwise specified, the characteristics of a shared pin are the same as those of a port pin.

Notes 1. For pins to which pull-up resistors are connected by the mask option, the rating is -0.3 to V_{DD} + 0.3.

2. To obtain the rms value, calculate [rms value] = [peak value] × √duty.

Notes 3. Permissible total power loss differs depending on the temperature (see the following figure).

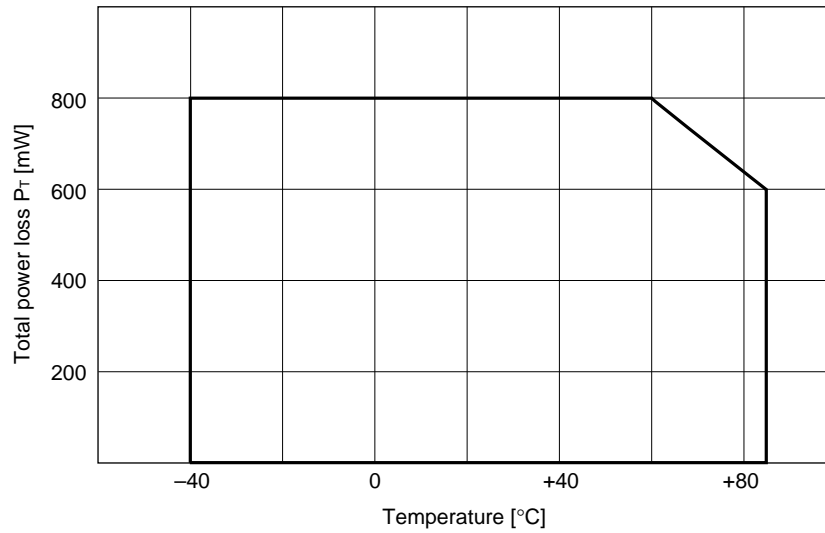

How to calculate total power loss

The following three power consumption are available for the μ PD78042F. The sum of the three power consumption should be less than the total power loss P_T (80 % or less of ratings is recommended).

- ① CPU power consumption: calculate $V_{DD} (MAX.) \times I_{DD1} (MAX.)$.
- ② Output pin power consumption: Normal output and display output are available. Power consumption when maximum current flows into each output pin.
- ③ Pull-down resistor power consumption: Power consumption by pull-down resistor connected to display output pin by the mask option.

The following total power consumption calculation example assumes the case where the characters shown in the figure on the next page are displayed.

Example: The operating conditions are as follows:

$V_{DD} = 5\text{ V} \pm 10\%$, operating at 5.0 MHz

Supply current (I_{DD}) = 21.6 mA

Display outputs: 11 grids × 10 segments (cut width is 1/16)

It is assumed that up to 15 mA flows to each grid pin, and that up to 3 mA flows to each segment pin.

It is also assumed that all display outputs are turned off at key scan timings.

Display output voltage: grid $V_{O3} = V_{DD} - 2\text{ V}$ (Voltage drop of 2 V is assumed.)

segment $V_{O3} = V_{DD} - 0.4\text{ V}$ (Voltage drop of 0.4 V is assumed.)

Voltage applied to fluorescent indication panel (V_{LOAD}) = -30 V

Mask-option pull-down resistor = 25 kΩ

The total power loss is calculated by determining power consumption ① to ③ under the above conditions.

① Power consumption of CPU: $5.5\text{ V} \times 21.6\text{ mA} = 118.8\text{ mW}$

② Power consumption at output pins:

$$\begin{aligned} \text{Grid: } & (V_{DD} - V_{O3}) \times \frac{\text{total current for all grids}}{\text{number of grids} + 1} \times \text{digit width} (1 - \text{cut width}) = \\ & 2\text{ V} \times \frac{15\text{ mA} \times 11\text{ grids}}{11\text{ grids} + 1} \times (1 - 1/16) = 25.8\text{ mW} \end{aligned}$$

$$\begin{aligned} \text{Segment: } & (V_{DD} - V_{O3}) \times \frac{\text{total segment current for all dots to be lit}}{\text{number of grids} + 1} = \\ & 0.4\text{ V} \times \frac{3\text{ mA} \times 31\text{ dots}}{11\text{ grids} + 1} = 3.1\text{ mW} \end{aligned}$$

③ Power consumption at pull-down resistors:

$$\begin{aligned} \text{Grid: } & \frac{(V_{O3} - V_{LOAD})^2}{\text{pull-down resistance}} \times \frac{\text{number of grids}}{\text{number of grids} + 1} \times \text{digit width} = \\ & \frac{(5.5\text{ V} - 2\text{ V} - (-30\text{ V}))^2}{25\text{ k}\Omega} \times \frac{11\text{ grids}}{11\text{ grids} + 1} \times (1 - 1/16) = 38.6\text{ mW} \end{aligned}$$

$$\begin{aligned} \text{Segment: } & \frac{(V_{O3} - V_{LOAD})^2}{\text{pull-down resistance}} \times \frac{\text{number of dots to be lit}}{\text{number of grids} + 1} = \\ & \frac{(5.5\text{ V} - 0.4\text{ V} - (-30\text{ V}))^2}{25\text{ k}\Omega} \times \frac{31\text{ dots}}{11\text{ grids} + 1} = 127.3\text{ mW} \end{aligned}$$

$$\text{Total power consumption} = \text{①} + \text{②} + \text{③} = 118.8 + 25.8 + 3.1 + 38.6 + 127.3 = 313.6\text{ mW}$$

In this example, the total power consumption does not exceed the rated value for the permissible total power loss shown in the graph on the previous page. Therefore, the calculation result in this example (313.6 mW) satisfies the requirement. If the total power consumption exceeded the rated value for the permissible total power loss, the power consumption must be reduced, by reducing the number of built-in pull-down resistors.

MAIN SYSTEM CLOCK OSCILLATOR CHARACTERISTICS (T_A = -40 to +85 °C, V_{DD} = 2.7 to 5.5 V)

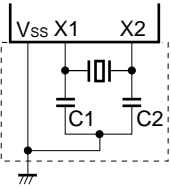
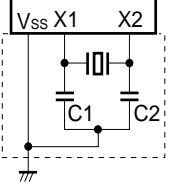
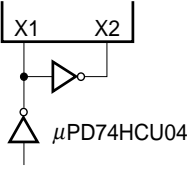
Resonator	Recommended circuit	Parameter	Conditions	MIN.	TYP.	MAX.	Unit
Ceramic resonator		Oscillation frequency (f _x) ^{Note 1}		1		5	MHz
		Oscillation settling time ^{Note 2}				4	ms
Crystal		Oscillation frequency (f _x) ^{Note 1}		1	4.19	5	MHz
		Oscillation settling time ^{Note 2}	V _{DD} = 4.5 to 5.5 V			10	ms
						30	
External clock		X1 input frequency (f _x) ^{Note 1}		1		5	MHz
		X1 input high, low-level width (t _{xH} , t _{xL})		100		500	ns

Notes 1. It indicates only the oscillator characteristics. For the instruction execution time, see the AC Characteristics.

2. Time required until oscillation becomes stable after V_{DD} is applied or the STOP mode is disabled.

Cautions 1. If the main system clock oscillator is to be used, wire the area inside the broken line square as follows to avoid influence of wiring capacitance:

- Make wiring as short as possible.
- Do not cross other signal lines.
- Do not get close to lines with fluctuating large current.
- Make sure that the connecting points of the capacitor of the oscillator always have the same electric potential as V_{SS}.
- Do not connect the oscillator to a ground pattern that conducts a large current.
- Do not take out signal from the oscillator.

2. When switching to the main system clock again after the subsystem clock has been used with the main system clock stopped, be sure to set the program to provide enough time for the oscillation to stabilize.

SUBSYSTEM CLOCK OSCILLATOR CHARACTERISTICS (T_A = -40 to +85 °C, V_{DD} = 2.7 to 5.5 V)

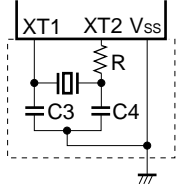
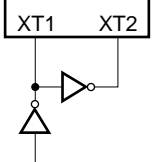
Resonator	Recommended circuit	Parameter	Conditions	MIN.	TYP.	MAX.	Unit
Crystal		Oscillation frequency (f _{XT}) ^{Note 1}		32	32.768	35	kHz
		Oscillation settling time ^{Note 2}	V _{DD} = 4.5 to 5.5 V		1.2	2	s
External		XT1 input frequency (f _{XT}) ^{Note 1}		32		100	kHz
		XT1 input high, low-level width (t _{XTH} , t _{XTL})		5		15	μs

Notes 1. It indicates only the oscillator characteristics. For the instruction execution time, see the AC Characteristics.

2. Time required until oscillation becomes stable after V_{DD} reaching MIN. of oscillation voltage range.

Cautions 1. If the subsystem clock oscillator is to be used, wire the area inside the broken line square as follows to avoid influence of wiring capacitance:

- Make wiring as short as possible.
 - Do not cross other signal lines.
 - Do not get close to lines with fluctuating large current.
 - Make sure that the connecting points of the capacitor of the oscillator always have the same electric potential as V_{ss}.
 - Do not connect the oscillator to a ground pattern that conducts a large current.
 - Do not take out signal from the oscillator.
- 2.** The subsystem clock oscillator is more likely to have malfunctions due to noise than the main system clock oscillator because gain for the subsystem clock oscillator is made lower to reduce current consumption. When using the subsystem clock, be careful about how to connect wires.

RECOMMENDED OSCILLATOR CONSTANT

MAIN SYSTEM CLOCK: CERAMIC RESONATOR (T_A = -40 to +85 °C)

Manufacturer	Product name	Frequency (MHz)	Recommended circuit constant		Oscillator voltage range		Remark
			C1 (pF)	C2 (pF)	MIN. (V)	MAX. (V)	
Murata Mfg. Co., Ltd.	CSB1000J	1.00	100	100	2.7	5.5	Rd = 4.7 kΩ ^{Note}
	CSA2.00MG040	2.00	100	100	2.7	5.5	
	CST2.00MG040	2.00	—	—	2.7	5.5	Built-in capacitor
	CSA4.00MG	4.00	30	30	2.7	5.5	
	CST4.00MGW	4.00	—	—	2.7	5.5	Built-in capacitor
	CSA5.00MG	5.00	30	30	2.7	5.5	
	CST5.00MGW	5.00	—	—	2.7	5.5	Built-in capacitor
TDK Corp.	CCR1000K2	1.00	150	150	2.7	5.5	Surface-mount type
	CCR2.0MC3	2.00	—	—	2.7	5.5	Built-in capacitor, surface-mount type
	CCR4.0MC3	4.00	—	—	2.7	5.5	Built-in capacitor, surface-mount type
	FCR4.0MC5	4.00	—	—	2.7	5.5	Built-in capacitor
	CCR5.0MC3	5.00	—	—	2.7	5.5	Built-in capacitor, surface-mount type
	FCR5.0MC5	5.00	—	—	2.7	5.5	Built-in capacitor
Matsushita Electronics Components Co., Ltd.	EFOEC2004A4	2.00	33	33	2.7	5.5	Built-in capacitor
	EFOS2004B5	2.00	33	33	2.7	5.5	Built-in capacitor, surface-mount type
	EFOEC3584A4	3.58	33	33	2.7	5.5	Built-in capacitor
	EFOS3584B5	3.58	33	33	2.7	5.5	Built-in capacitor, surface-mount type
	EFOEC4004A4	4.00	33	33	2.7	5.5	Built-in capacitor
	EFOS4004B5	4.00	33	33	2.7	5.5	Built-in capacitor, surface-mount type
	EFOEC5004A4	5.00	33	33	2.7	5.5	Built-in capacitor
	EFOS5004B5	5.00	33	33	2.7	5.5	Built-in capacitor, surface-mount type

Note When the CSB1000J (1.00 MHz) manufactured by Murata Mfg. is used, a limiting resistor (4.7 kΩ) is necessary (see the figure in the next page). When one of other resonators is used, no limiting resistor is required.

Caution The oscillation circuit constants and oscillation voltage range indicate conditions for stable oscillation but do not guarantee accuracy of the oscillation frequency. If the application circuit requires accuracy of the oscillation frequency, it is necessary to set the oscillation frequency of the resonator in the application circuit. For this, it is necessary to directly contact the manufacturer of the resonator that being used.

Recommended sample circuit for the main system clock when the CSB1000J manufactured by Murata Mfg. is used

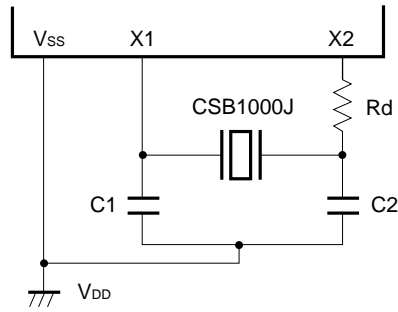

CAPACITANCE (T_A = 25 °C, V_{DD} = V_{SS} = 0 V)

Parameter	Symbol	Conditions	MIN.	TYP.	MAX.	Unit	
Input capacitance	C _{IN}	f = 1 MHz Unmeasured pins returned to 0 V			15	pF	
Output capacitance	C _{OUT}	f = 1 MHz Unmeasured pins returned to 0 V			35	pF	
Input/output capacitance	C _{IO}	f = 1 MHz Unmeasured pins returned to 0 V			15	pF	
					P01-P03, P10-P17, P20-P27, P30-P37	20	pF
					P70-P74	35	pF
		P110-P117, P120-P127					

Remark Unless otherwise specified, the characteristics of the shared pin are the same as the characteristics of the port pin.

POWER SUPPLY VOLTAGE (T_A = -40 to +85 °C)

Parameter	Conditions	MIN.	TYP.	MAX.	Unit
CPU ^{Note 1}		2.7 ^{Note 2}		5.5	V
Display controller/driver		4.5		5.5	V
PWM mode of 16-bit timer/event counter (TM0)		4.5		5.5	V
A/D converter		4.0		5.5	V
Other hardware		2.7		5.5	V

Notes 1. Except for system clock oscillator, display controller/driver, and PWM.

2. Operating power supply voltage differs depending on the cycle time. See the **AC Characteristics**.

DC CHARACTERISTICS (T_A = -40 to +85 °C, V_{DD} = 2.7 to 5.5 V)

Parameter	Symbol	Conditions	MIN.	TYP.	MAX.	Unit	
High-level input voltage	V _{IH1}	P21, P23	0.7V _{DD}		V _{DD}	V	
	V _{IH2}	P00-P03, P20, P22, P24-P27, P33, P34, $\overline{\text{RESET}}$	0.8V _{DD}		V _{DD}	V	
	V _{IH3}	P70-P74	N-ch open drain	0.7V _{DD}	15 ^{Note 1}	V	
	V _{IH4}	X1, X2 ^{Note 2}		V _{DD} - 0.5	V _{DD}	V	
	V _{IH5}	XT1/P04, XT2 ^{Note 2}	V _{DD} = 4.5 to 5.5 V	V _{DD} - 0.5	V _{DD}	V	
				V _{DD} - 0.3	V _{DD}	V	
	V _{IH6}	P10-P17, P30-P32, P35-P37	V _{DD} = 4.5 to 5.5 V	0.65V _{DD}	V _{DD}	V	
			0.7V _{DD}	V _{DD}	V		
V _{IH7}	P110-P117, P120-P127	V _{DD} = 4.5 to 5.5 V	0.7V _{DD}	V _{DD}	V		
			V _{DD} - 0.5	V _{DD}	V		
Low-level input voltage	V _{IL1}	P21, P23	0		0.3V _{DD}	V	
	V _{IL2}	P00-P03, P20, P22, P24-P27, P33, P34, $\overline{\text{RESET}}$	0		0.2V _{DD}	V	
	V _{IL3}	P70-P74	V _{DD} = 4.5 to 5.5 V	0		0.3V _{DD}	V
				0		0.2V _{DD}	V
	V _{IL4}	X1, X2 ^{Note 2}		0		0.4	V
	V _{IL5}	XT1/P04, XT2 ^{Note 2}	V _{DD} = 4.5 to 5.5 V	0		0.4	V
				0		0.3	V
V _{IL6}	P10-P17, P30-P32, P35-P37		0		0.3V _{DD}	V	
V _{IL7}	P110-P117, P120-P127		V _{DD} - 35		0.3V _{DD}	V	
High-level output voltage	V _{OH}	P01-P03, P10-P17, P20-P27, P30-P37, P80, P81, P90-P97, P100-P107, P110-P117, P120-P127	V _{DD} = 4.5 to 5.5 V I _{OH} = -1 mA	V _{DD} - 1.0		V	
			I _{OH} = -100 μA	V _{DD} - 0.5		V	
Low-level output voltage	V _{OL1}	P30-P37, P70-P74	V _{DD} = 4.5 to 5.5 V, I _{OL} = 15 mA		0.4	2.0	V
		P01-P03, P10-P17, P20-P27	V _{DD} = 4.5 to 5.5 V, I _{OL} = 1.6 mA			0.4	V
	V _{OL2}	SB0, SB1, $\overline{\text{SCK0}}$	V _{DD} = 4.5 to 5.5 V, With open-drain and pull-up (R = 1 kΩ)			0.2V _{DD}	V
	V _{OL3}	P01-P03, P10-P17, P20-P27, P30-P37, P70-P74	I _{OL} = 400 μA			0.5	V

Notes 1. Pins to which pull-up resistors are connected by the mask option become V_{DD}.

2. If the X1 pin is used for high-level voltage input, the X2 pin is used for low-level voltage input, or vice versa. This is also true for the XT1/P04 pin and XT2 pin.

Remark Unless otherwise specified, the characteristics of a shared pin are the same as those of a port pin.

DC CHARACTERISTICS (T_A = -40 to +85 °C, V_{DD} = 2.7 to 5.5 V)

Parameter	Symbol	Conditions		MIN.	TYP.	MAX.	Unit
High-level input leakage current	I _{LIH1}	V _{IN} = V _{DD}	P00-P03, P10-P17, P20-P27, P30-P37, $\overline{\text{RESET}}$			3	μA
	I _{LIH2}		X1, X2, XT1/P04, XT2			20	μA
	I _{LIH3}	V _{IN} = 15 V	P70-P74			20	μA
	I _{LIH4}	P110-P117, P120-P127, V _{IN} = V _{DD}	V _{DD} = 4.5 to 5.5 V			3Note 1	μA
					3Note 2	μA	
Low-level input leakage current	I _{LIL1}	V _{IN} = 0 V	P00-P03, P10-P17, P20-P27, P30-P37, $\overline{\text{RESET}}$			-3	μA
	I _{LIL2}		X1, X2, XT1/P04, XT2			-20	μA
	I _{LIL3}		P70-P74			-3Note 3	μA
	I _{LIL4}		P110-P117, P120-P127			-10	μA
High-level output leakage currentNote 4	I _{LOH1}	V _{OUT} = V _{DD}	P01-P03, P10-P17, P20-P27, P30-P37, P80, P81, P90-P97, P100-P107, P110-P117, P120-P127			3	μA
	I _{LOH2}		V _{OUT} = 15 V	P70-74, N-ch open drain			20
Low-level output leakage currentNote 4	I _{LOL1}	V _{OUT} = 0 V	P01-P03, P10-P17, P20-P27, P30-P37, P70-P74			-3	μA
	I _{LOL2}	V _{OUT} = V _{LOAD} = V _{DD} - 35 V	P80, P81, P90-P97, P100-P107, P110-P117, P120-P127			-10	μA
Display output current	I _{OD}	V _{DD} = 4.5 to 5.5 V, V _{O3} = V _{DD} - 2 V		-15	-25		mA
Mask option pull-up resistor	R ₁	V _{IN} = 0 V, P70-P74		20	40	90	k Ω
Software pull-up resistor	R ₂	V _{IN} = 0 V, P01-P03, P10-P17, P20-P27, P30-P37	V _{DD} = 4.5 to 5.5 V	15	40	90	k Ω
				20		500	k Ω
Mask option pull-down resistor	R ₃	P80, P81, P90-P97, P100-P107, P110-P117, P120-P127	V _{O3} - V _{LOAD} = 35 V	25	65	135	k Ω
			V _{O3} - V _{SS} = 5 V	15	40	90	k Ω
	R ₄	P30-P37, V _{IN} = V _{DD}	40	80	150	k Ω	

- Notes 1.** When P110 to P117 and P120 to P127 do not contain the pull-down resistors (according to the specification of the mask option), a high-level input leakage current of 150 μA (MAX.) flows only during 1.5 clocks after a read instruction has been executed to read out port 11 or 12 (P11 or P12) or port mode register 11 or 12 (PM11 or PM12). Outside the 1.5 clocks after a read instruction, the current is 3 μA (MAX.).
- 2.** When P110 to P117 and P120 to P127 do not contain the pull-down resistors (according to the specification of the mask option), a high-level input leakage current of 90 μA (MAX.) flows only during 1.5 clocks after a read instruction has been executed to read out P11, P12, PM11, or PM12. Outside the 1.5 clocks after a read instruction, the current is 3 μA (MAX.).
- 3.** When P70 to P74 do not contain the pull-down resistors (according to the specification of the mask option), a low-level input leakage current of -150 μA (MAX.) flows only during 1.5 clocks after a read instruction has been executed to read out port 7 (P7) or port mode register 7 (PM7). Outside the 1.5 clocks after a read out instruction, the current is -3 μA (MAX.).
- 4.** Current which flows in the built-in pull-up or pull-down resistor is not included.

Remark Unless otherwise specified, the characteristics of a shared pin are the same as those of a port pin.

DC CHARACTERISTICS (T_A = -40 to +85 °C, V_{DD} = 2.7 to 5.5 V)

Parameter	Symbol	Conditions	MIN.	TYP.	MAX.	Unit	
Power supply current ^{Note 1}	I _{DD1}	5.0 MHz crystal oscillation Operating mode	V _{DD} = 5.0 V ±10 % ^{Note 2}		7.2	21.6	mA
			V _{DD} = 3.0 V ±10 % ^{Note 3}		0.9	2.7	mA
	I _{DD2}	5.0 MHz crystal oscillation HALT mode	V _{DD} = 5.0 V ±10 %		1.3	3.9	mA
			V _{DD} = 3.0 V ±10 %		550	1650	μA
	I _{DD3}	32.768 kHz crystal oscillation Operating mode ^{Note 4}	V _{DD} = 5.0 V ±10 %		60	120	μA
			V _{DD} = 3.0 V ±10 %		35	70	μA
	I _{DD4}	32.768 kHz crystal oscillation HALT mode ^{Note 4}	V _{DD} = 5.0 V ±10 %		25	50	μA
			V _{DD} = 3.0 V ±10 %		5	10	μA
	I _{DD5}	XT1 = 0 V STOP mode Feedback resistor connected	V _{DD} = 5.0 V ±10 %		1	20	μA
			V _{DD} = 3.0 V ±10 %		0.5	10	μA
	I _{DD6}	XT1 = 0 V STOP mode Feedback resistor not connected	V _{DD} = 5.0 V ±10 %		0.1	20	μA
			V _{DD} = 3.0 V ±10 %		0.05	10	μA

- Notes**
1. This current excludes the AV_{REF} current, port current, and current which flows in the built-in pull-down resistor (mask option).
 2. When operating at high-speed mode (when the processor clock control register (PCC) is set to 00H)
 3. When operating at low-speed mode (when the PCC is set to 04H)
 4. When the main system clock is stopped

AC CHARACTERISTICS

(1) Basic operation (T_A = -40 to +85 °C, V_{DD} = 2.7 to 5.5 V)

Parameter	Symbol	Conditions	MIN.	TYP.	MAX.	Unit	
Cycle time (minimum instruction execution time)	T _{CY}	Operated with main system clock	V _{DD} = 4.5 to 5.5 V	0.4		32	μs
				0.8		32	μs
		Operated with subsystem clock	40 ^{Note 1}	122	125	μs	
T11, 2 input frequency	f _{T1}	V _{DD} = 4.5 to 5.5 V		0	2	MHz	
				0	138	kHz	
T11, 2 input high, low-level width	t _{TIH}	V _{DD} = 4.5 to 5.5 V		250		ns	
	t _{TIL}			3.6		μs	
Interrupt input high, low-level width	t _{INTH}	INTP0	8/f _{sam}	^{Note 2}		μs	
	t _{INTL}	INTP1-INTP3	10			μs	
RESET low-level width	t _{RSL}		10			μs	

- Notes**
- Value when external clock input is used as subsystem clock. When crystal is used, the value becomes 114 μs.
 - Selection of f_{sam} = f_x/2^{N+1}, f_x/64, f_x/128 is available (N = 0 to 4) by bits 0 and 1 (SCS0, SCS1) of sampling clock select register (SCS).

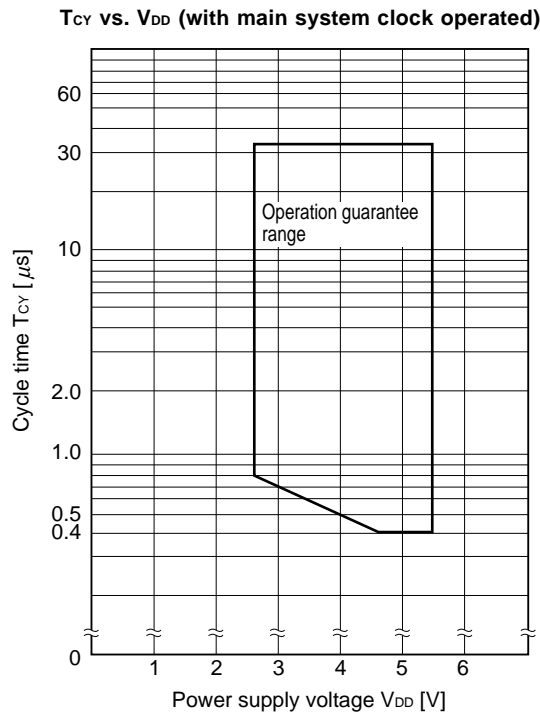

(2) Serial interface (T_A = -40 to +85 °C, V_{DD} = 2.7 to 5.5 V)

(a) Serial interface channel 0

(i) Three-wire serial I/O mode ($\overline{\text{SCK0}}$: Internal clock output)

Parameter	Symbol	Conditions	MIN.	TYP.	MAX.	Unit
$\overline{\text{SCK0}}$ cycle time	t _{KCY1}	V _{DD} = 4.5 to 5.5 V	800			ns
			3200			ns
$\overline{\text{SCK0}}$ high, low-level width	t _{KH1}	V _{DD} = 4.5 to 5.5 V	t _{KCY1} /2 - 50			ns
	t _{KL1}		t _{KCY1} /2 - 150			ns
SI0 setup time to $\overline{\text{SCK0}}\uparrow$	t _{SIK1}		100			ns
SI0 hold time from $\overline{\text{SCK0}}\uparrow$	t _{KS1}		400			ns
$\overline{\text{SCK0}}\downarrow \rightarrow$ SO0 output delay time	t _{KSO1}	C = 100 pF ^{Note} V _{DD} = 4.5 to 5.5 V			300	ns
					1000	ns

Note C is a load capacitance of the $\overline{\text{SCK0}}$ or SO0 output line.

(ii) Three-wire serial I/O mode ($\overline{\text{SCK0}}$: External clock input)

Parameter	Symbol	Conditions	MIN.	TYP.	MAX.	Unit
$\overline{\text{SCK0}}$ cycle time	t _{KCY2}	V _{DD} = 4.5 to 5.5 V	800			ns
			3200			ns
$\overline{\text{SCK0}}$ high, low-level width	t _{KH2}	V _{DD} = 4.5 to 5.5 V	400			ns
	t _{KL2}		1600			ns
SI0 setup time to $\overline{\text{SCK0}}\uparrow$	t _{SIK2}	V _{DD} = 4.5 to 5.5 V	100			ns
SI0 hold time from $\overline{\text{SCK0}}\uparrow$	t _{KS2}		400			ns
$\overline{\text{SCK0}}\downarrow \rightarrow$ SO0 output delay time	t _{KSO2}	C = 100 pF ^{Note} V _{DD} = 4.5 to 5.5 V			300	ns
					1000	ns
$\overline{\text{SCK0}}$ rise time and fall time	t _{R2}				160	ns
	t _{F2}					

Note C is a load capacitance of the SO0 output line.

(iii) SBI mode ($\overline{\text{SCK0}}$: Internal clock output)

Parameter	Symbol	Conditions		MIN.	TYP.	MAX.	Unit
$\overline{\text{SCK0}}$ cycle time	t_{KCY3}	$V_{\text{DD}} = 4.5 \text{ to } 5.5 \text{ V}$		800			ns
				3200			ns
$\overline{\text{SCK0}}$ high, low-level width	t_{KH3}	$V_{\text{DD}} = 4.5 \text{ to } 5.5 \text{ V}$		$t_{\text{KCY3}}/2 - 50$			ns
	t_{KL3}			$t_{\text{KCY3}}/2 - 150$			ns
SB0, SB1 setup time to $\overline{\text{SCK0}}\uparrow$	t_{SIK3}	$V_{\text{DD}} = 4.5 \text{ to } 5.5 \text{ V}$		100			ns
				300			ns
SB0, SB1 hold time from $\overline{\text{SCK0}}\uparrow$	t_{KSI3}			$t_{\text{KCY3}}/2$			ns
$\overline{\text{SCK0}}\downarrow \rightarrow$ SB0, SB1 output delay time	t_{KSO3}	R = 1 kΩ, C = 100 pF ^{Note}	$V_{\text{DD}} = 4.5 \text{ to } 5.5 \text{ V}$	0		250	ns
				0		1000	ns
$\overline{\text{SCK0}}\uparrow \rightarrow$ SB0, SB1↓	t_{KSB}			t_{KCY3}			ns
SB0, SB1↓ \rightarrow $\overline{\text{SCK0}}\downarrow$	t_{SBK}			t_{KCY3}			ns
SB0, SB1 high-level width	t_{SBH}			t_{KCY3}			ns
SB0, SB1 low-level width	t_{SBL}			t_{KCY3}			ns

Note R is a load resistance of the $\overline{\text{SCK0}}$, SB0, or SB1 output line, and C is its load capacitance.

(iv) SBI mode ($\overline{\text{SCK0}}$: External clock input)

Parameter	Symbol	Conditions		MIN.	TYP.	MAX.	Unit
$\overline{\text{SCK0}}$ cycle time	t_{KCY4}	$V_{\text{DD}} = 4.5 \text{ to } 5.5 \text{ V}$		800			ns
				3200			ns
$\overline{\text{SCK0}}$ high, low-level width	t_{KH4}	$V_{\text{DD}} = 4.5 \text{ to } 5.5 \text{ V}$		400			ns
	t_{KL4}			1600			ns
SB0, SB1 setup time to $\overline{\text{SCK0}}\uparrow$	t_{SIK4}	$V_{\text{DD}} = 4.5 \text{ to } 5.5 \text{ V}$		100			ns
				300			ns
SB0, SB1 hold time from $\overline{\text{SCK0}}\uparrow$	t_{KSI4}			$t_{\text{KCY4}}/2$			ns
$\overline{\text{SCK0}}\downarrow \rightarrow$ SB0, SB1 output delay time	t_{KSO4}	R = 1 kΩ, C = 100 pF ^{Note}	$V_{\text{DD}} = 4.5 \text{ to } 5.5 \text{ V}$	0		300	ns
				0		1000	ns
$\overline{\text{SCK0}}\uparrow \rightarrow$ SB0, SB1↓	t_{KSB}			t_{KCY4}			ns
SB0, SB1↓ \rightarrow $\overline{\text{SCK0}}\downarrow$	t_{SBK}			t_{KCY4}			ns
SB0, SB1 high-level width	t_{SBH}			t_{KCY4}			ns
SB0, SB1 low-level width	t_{SBL}			t_{KCY4}			ns
$\overline{\text{SCK0}}$ rise time and fall time	t_{r4}					160	ns
	t_{f4}						

Note R is a load resistance of the SB0 or SB1 output line, and C is its load capacitance.

(v) Two-wire serial I/O mode ($\overline{\text{SCK0}}$: Internal clock output)

Parameter	Symbol	Conditions	MIN.	TYP.	MAX.	Unit	
$\overline{\text{SCK0}}$ cycle time	t_{CY5}	R = 1 kΩ, C = 100 pF ^{Note}	V _{DD} = 4.5 to 5.5 V	1600			ns
				3800			ns
$\overline{\text{SCK0}}$ high-level width	t_{KH5}			$t_{\text{CY5}}/2 - 160$			ns
$\overline{\text{SCK0}}$ low-level width	t_{KL5}			$t_{\text{CY5}}/2 - 50$			ns
SB0, SB1 setup time to $\overline{\text{SCK0}}\uparrow$	t_{SIK5}		300				ns
SB0, SB1 hold time from $\overline{\text{SCK0}}\uparrow$	t_{SI5}		600				ns
$\overline{\text{SCK0}}\downarrow\rightarrow$ SB0, SB1 output delay time	t_{SO5}		V _{DD} = 4.5 to 5.5 V	0		250	ns
				0		1000	ns

Note R is a load resistance of the $\overline{\text{SCK0}}$, SB0, or SB1 output line, and C is its load capacitance.

(vi) Two-wire serial I/O mode ($\overline{\text{SCK0}}$: External clock input)

Parameter	Symbol	Conditions	MIN.	TYP.	MAX.	Unit	
$\overline{\text{SCK0}}$ cycle time	t_{CY6}	V _{DD} = 4.5 to 5.5 V		1600			ns
				3800			ns
$\overline{\text{SCK0}}$ high-level width	t_{KH6}		650				ns
$\overline{\text{SCK0}}$ low-level width	t_{KL6}		800				ns
SB0, SB1 setup time to $\overline{\text{SCK0}}\uparrow$	t_{SIK6}		100				ns
SB0, SB1 hold time from $\overline{\text{SCK0}}\uparrow$	t_{SI6}			$t_{\text{CY6}}/2$			ns
$\overline{\text{SCK0}}\downarrow\rightarrow$ SB0, SB1 output delay time	t_{SO6}	R = 1 kΩ, C = 100 pF ^{Note}	V _{DD} = 4.5 to 5.5 V	0		300	ns
				0		1000	ns
$\overline{\text{SCK0}}$ rise time and fall time	t_{r6}					160	ns
	t_{f6}						

Note R is a load resistance of the SB0 or SB1 output line, and C is its load capacitance.

(b) Serial interface channel 1

(i) Three-wire serial I/O mode ($\overline{\text{SCK1}}$: Internal clock output)

Parameter	Symbol	Conditions		MIN.	TYP.	MAX.	Unit
$\overline{\text{SCK1}}$ cycle time	t_{KCY7}	$V_{\text{DD}} = 4.5 \text{ to } 5.5 \text{ V}$		800			ns
				3200			ns
$\overline{\text{SCK1}}$ high, low-level width	t_{KH7}	$V_{\text{DD}} = 4.5 \text{ to } 5.5 \text{ V}$		$t_{\text{KCY7}}/2 - 50$			ns
	t_{KL7}			$t_{\text{KCY7}}/2 - 150$			ns
SI1 setup time to $\overline{\text{SCK1}}\uparrow$	t_{SIK7}			100			ns
SI1 hold time from $\overline{\text{SCK1}}\uparrow$	t_{KSI7}			400			ns
$\overline{\text{SCK1}}\downarrow \rightarrow$ SO1 output delay time	t_{KSO7}	$C = 100 \text{ pF}^{\text{Note}}$	$V_{\text{DD}} = 4.5 \text{ to } 5.5 \text{ V}$			300	ns
						1000	ns

Note C is a load capacitance of the $\overline{\text{SCK1}}$ or SO1 output line.

(ii) Three-wire serial I/O mode ($\overline{\text{SCK1}}$: External clock input)

Parameter	Symbol	Conditions		MIN.	TYP.	MAX.	Unit
$\overline{\text{SCK1}}$ cycle time	t_{KCY8}	$V_{\text{DD}} = 4.5 \text{ to } 5.5 \text{ V}$		800			ns
				3200			ns
$\overline{\text{SCK1}}$ high, low-level width	t_{KH8}	$V_{\text{DD}} = 4.5 \text{ to } 5.5 \text{ V}$		400			ns
	t_{KL8}			1600			ns
SI1 setup time to $\overline{\text{SCK1}}\uparrow$	t_{SIK8}	$V_{\text{DD}} = 4.5 \text{ to } 5.5 \text{ V}$		100			ns
SI1 hold time from $\overline{\text{SCK1}}\uparrow$	t_{KSI8}			400			ns
$\overline{\text{SCK1}}\downarrow \rightarrow$ SO1 output delay time	t_{KSO8}	$C = 100 \text{ pF}^{\text{Note}}$	$V_{\text{DD}} = 4.5 \text{ to } 5.5 \text{ V}$			300	ns
						1000	ns
$\overline{\text{SCK1}}$ rise time and fall time	t_{R8}					160	ns
	t_{F8}						

Note C is a load capacitance of the SO1 output line.

(iii) 3-wire serial I/O mode with automatic transmission/reception function ($\overline{\text{SCK1}}$: internal clock output)

Parameter	Symbol	Conditions	MIN.	TYP.	MAX.	Unit
$\overline{\text{SCK1}}$ cycle time	t_{KCY9}	$V_{\text{DD}} = 4.5 \text{ to } 5.5 \text{ V}$	800			ns
			3200			ns
$\overline{\text{SCK1}}$ high, low-level width	t_{KH9}	$V_{\text{DD}} = 4.5 \text{ to } 5.5 \text{ V}$	$t_{\text{KCY9}}/2 - 50$			ns
	t_{KL9}		$t_{\text{KCY9}}/2 - 150$			ns
SI1 setup time to $\overline{\text{SCK1}}\uparrow$	t_{SIK9}		100			ns
SI1 hold time from $\overline{\text{SCK1}}\uparrow$	t_{KSI9}		400			ns
$\overline{\text{SCK1}}\downarrow \rightarrow \text{SO1}$ output delay time	t_{KSO9}	$C = 100 \text{ pF}^{\text{Note}}$	$V_{\text{DD}} = 4.5 \text{ to } 5.5 \text{ V}$		300	ns
					1000	ns
$\overline{\text{SCK1}}\uparrow \rightarrow \text{STB}\infty$	t_{SBD}		$t_{\text{KCY9}}/2 - 100$		$t_{\text{KCY9}}/2 + 100$	ns
Strobe signal high level width	t_{SBW}		$t_{\text{KCY9}} - 30$		$t_{\text{KCY9}} + 30$	ns
Busy signal setup time (to busy signal detection timing)	t_{BYS}		100			ns
Busy signal hold time (to busy signal detection timing)	t_{BYH}		100			ns
Busy inactive $\rightarrow \overline{\text{SCK1}}\downarrow$	t_{SPS}				$2t_{\text{KCY9}}$	ns

Note C is a load capacitance of the $\overline{\text{SCK1}}$ or SO1 output line.

(iv) 3-wire serial I/O mode with automatic transmission/reception function ($\overline{\text{SCK1}}$: external clock input)

Parameter	Symbol	Conditions	MIN.	TYP.	MAX.	Unit
$\overline{\text{SCK1}}$ cycle time	t_{KCY10}	$V_{\text{DD}} = 4.5 \text{ to } 5.5 \text{ V}$	800			ns
			3200			ns
$\overline{\text{SCK1}}$ high, low-level width	t_{KH10}	$V_{\text{DD}} = 4.5 \text{ to } 5.5 \text{ V}$	400			ns
	t_{KL10}		1600			ns
SI1 setup time to $\overline{\text{SCK1}}\uparrow$	t_{SIK10}		100			ns
SI1 hold time from $\overline{\text{SCK1}}\uparrow$	t_{KSI10}		400			ns
$\overline{\text{SCK1}}\downarrow \rightarrow \text{SO1}$ output delay time	t_{KSO10}	$C = 100 \text{ pF}^{\text{Note}}$	$V_{\text{DD}} = 4.5 \text{ to } 5.5 \text{ V}$		300	ns
					1000	ns
$\overline{\text{SCK1}}$ rise time and fall time	t_{R10}				160	ns
	t_{F10}					ns

Note C is a load capacitance of the SO1 output line.

AC timing test points (except X1, XT1 input)

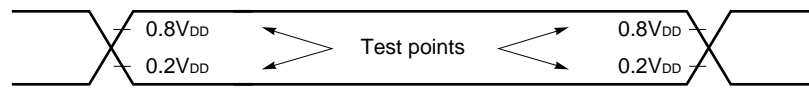

Clock timing

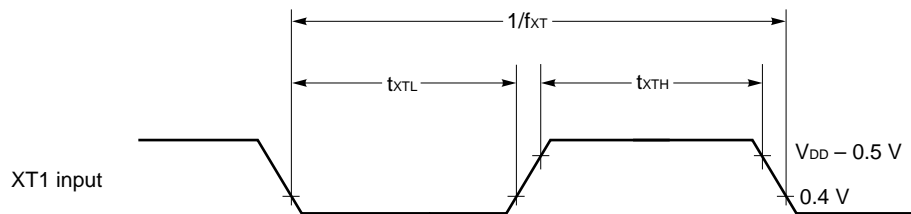
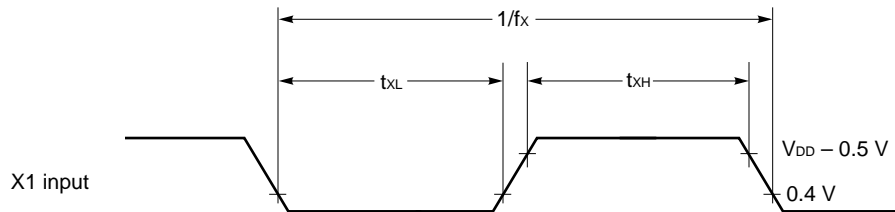

TI timing

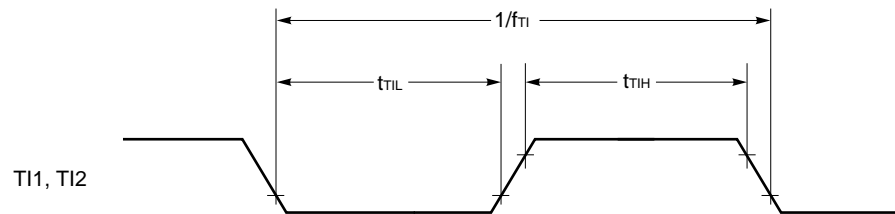

Serial transfer timing

3-wire serial I/O mode:

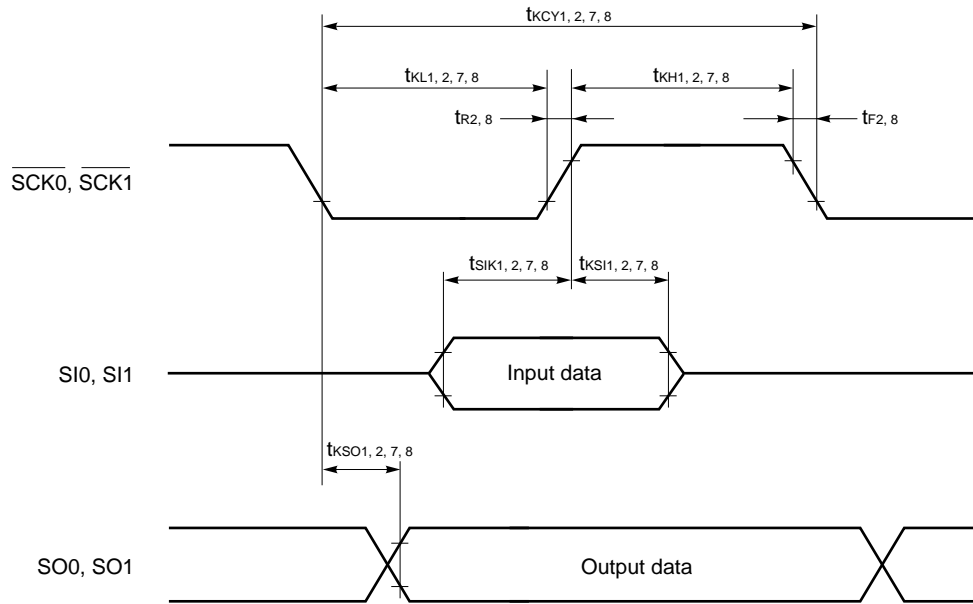

SBI mode (bus release signal transfer):

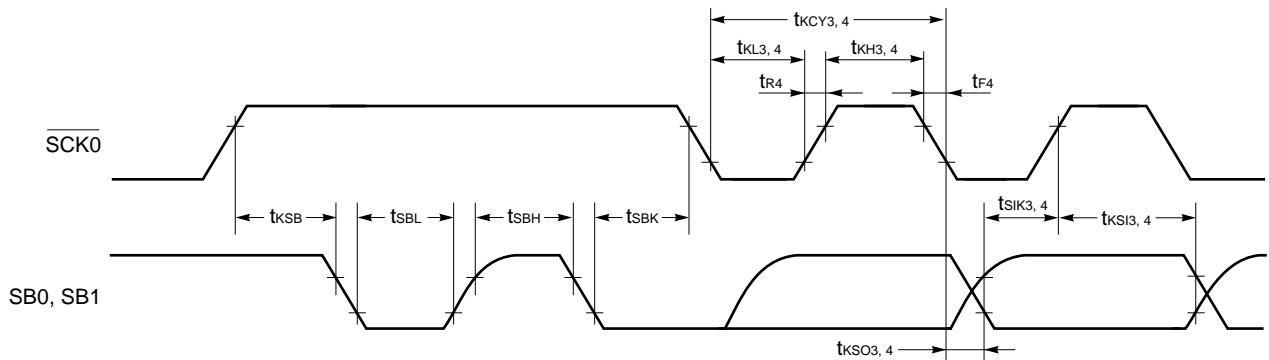

SBI mode (command signal transfer):

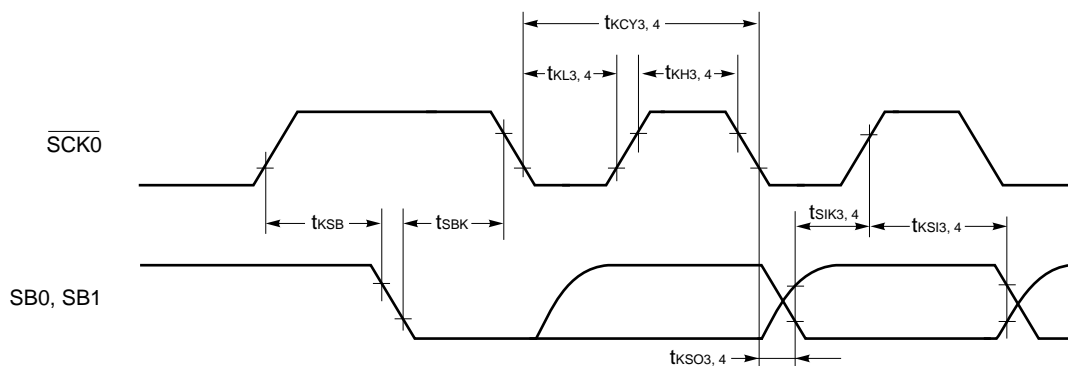

2-wire serial I/O mode:

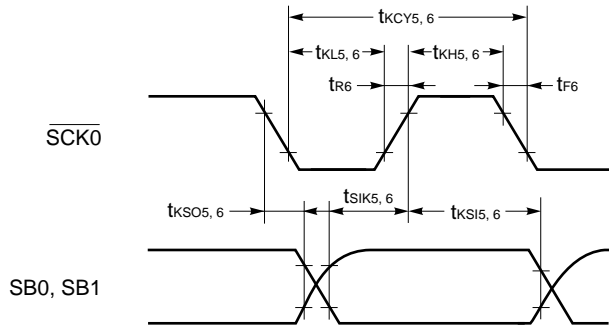

3-wire serial I/O mode with automatic transmission/reception function:

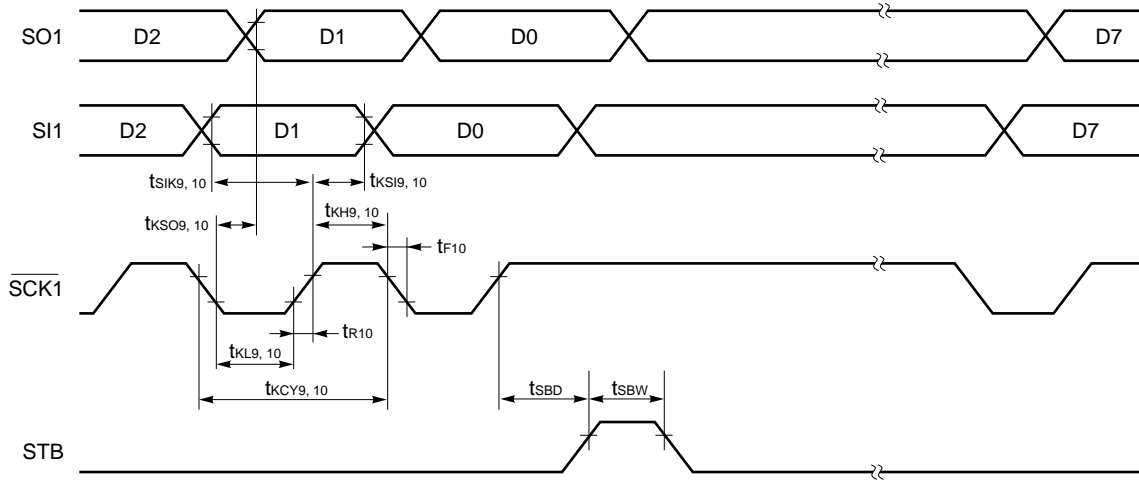

3-wire serial I/O mode with automatic transmission/reception function (busy processing):

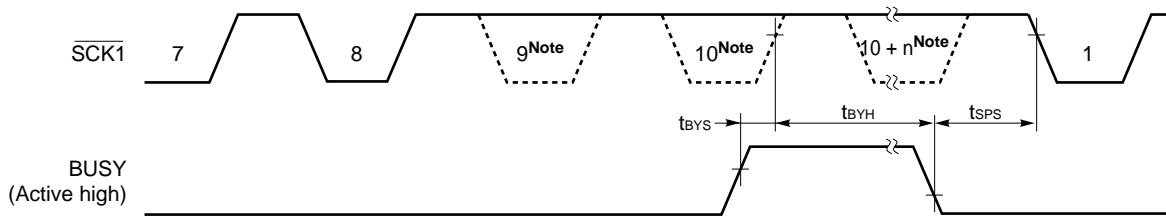

Note $\overline{\text{SCK}}$ does not become low actually at this point, but is indicated so to conform to the timing specification.

A/D CONVERTER CHARACTERISTICS ($T_A = -40$ to $+85$ °C, $AV_{DD} = V_{DD} = 4.0$ to 5.5 V, $AV_{SS} = V_{SS} = 0$ V)

Parameter	Symbol	Conditions	MIN.	TYP.	MAX.	Unit
Resolution			8	8	8	bit
Total error ^{Note 1}					0.8	%
Conversion time ^{Note 2}	t _{CONV}	1 MHz - f _x - 5.0 MHz	19.1		200	μ s
Sampling time ^{Note 3}	t _{SAMP}		2.86		30	μ s
Analog signal input voltage	V _{IAN}		AV _{SS}		AV _{REF}	V
Reference voltage	AV _{REF}		4.0		AV _{DD}	V
AV _{REF} resistor	R _{AVREF}		4	14		k Ω
AV _{DD} current	AI _{DD}			200	400	μ A

- Notes**
1. Quantization error ($\pm 1/2$ LSB) is not included. This parameter is indicated as the ratio to the full-scale value.
 2. Set the A/D conversion time to 19.1 μ s or more.
 3. Sampling time depends on the conversion time.

DATA MEMORY STOP MODE LOW SUPPLY VOLTAGE DATA RETENTION CHARACTERISTICS

($T_A = -40$ to $+85$ °C)

Parameter	Symbol	Conditions	MIN.	TYP.	MAX.	Unit
Data retention supply voltage	V_{DDDR}		2.0		5.5	V
Data retention supply current	I_{DDDR}	$V_{DDDR} = 2.0$ V Subsystem clock stopped Feedback resistor not connected		0.1	10	μ A
Release signal set time	t_{SREL}		0			μ s
Oscillation stabilization wait time	t_{WAIT}	Release by \overline{RESET}		$2^{17}/f_x$		ms
		Release by interrupt		Note		ms

Note Selection of $2^{12}/f_x$, $2^{14}/f_x$ to $2^{17}/f_x$ is available by bits 0 to 2 (OSTS0 to OSTS2) of oscillation settling time select register (OSTS).

Data retention timing (STOP mode release by \overline{RESET})

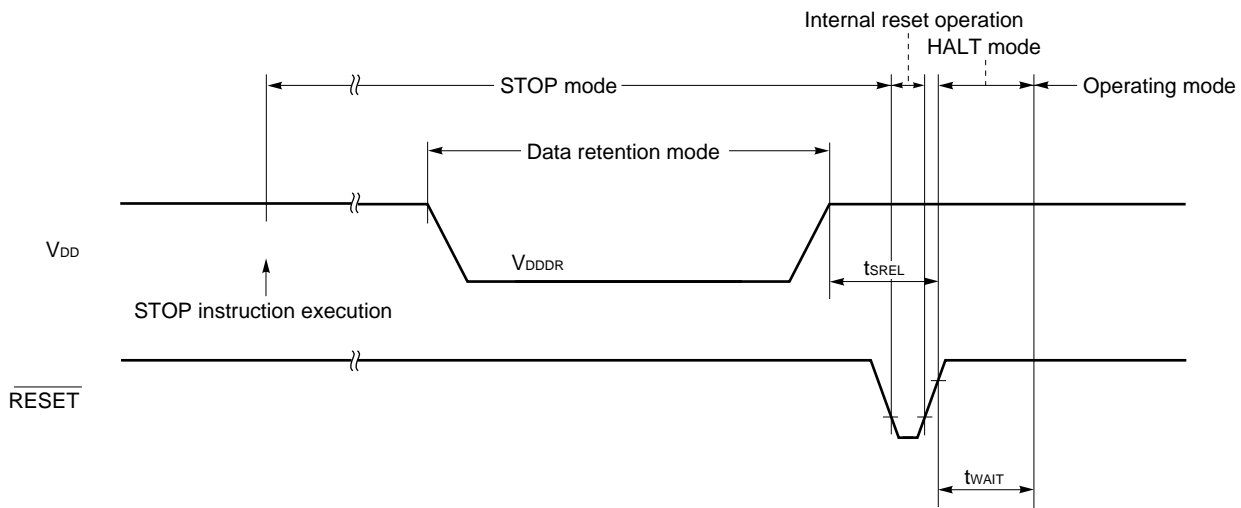

Data retention timing (standby release signal: STOP mode release by interrupt signal)

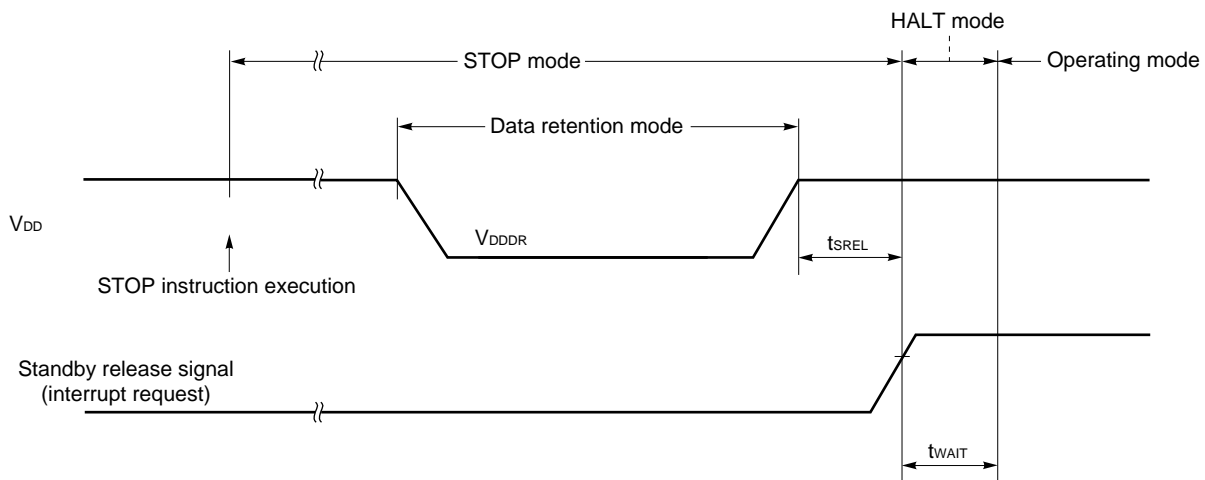

Interrupt input timing

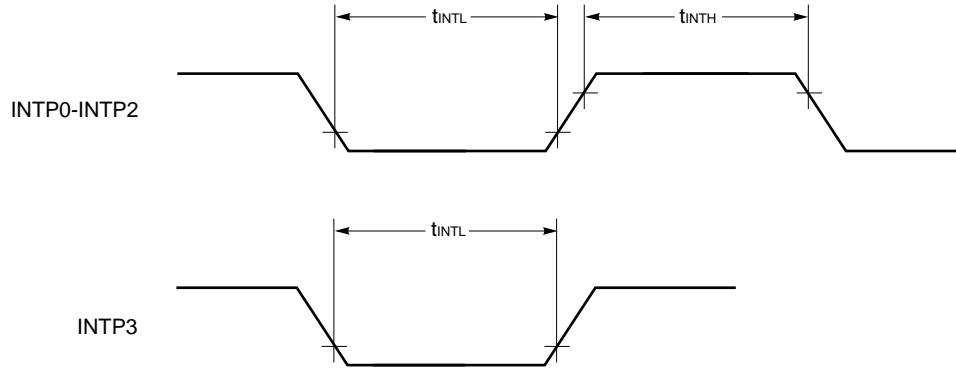

$\overline{\text{RESET}}$ input timing

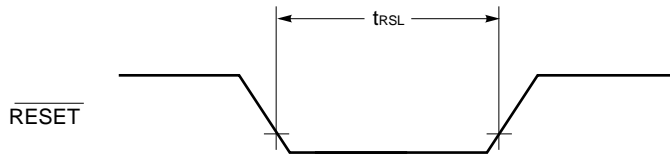

★ 11. CHARACTERISTIC CURVE (REFERENCE VALUE)

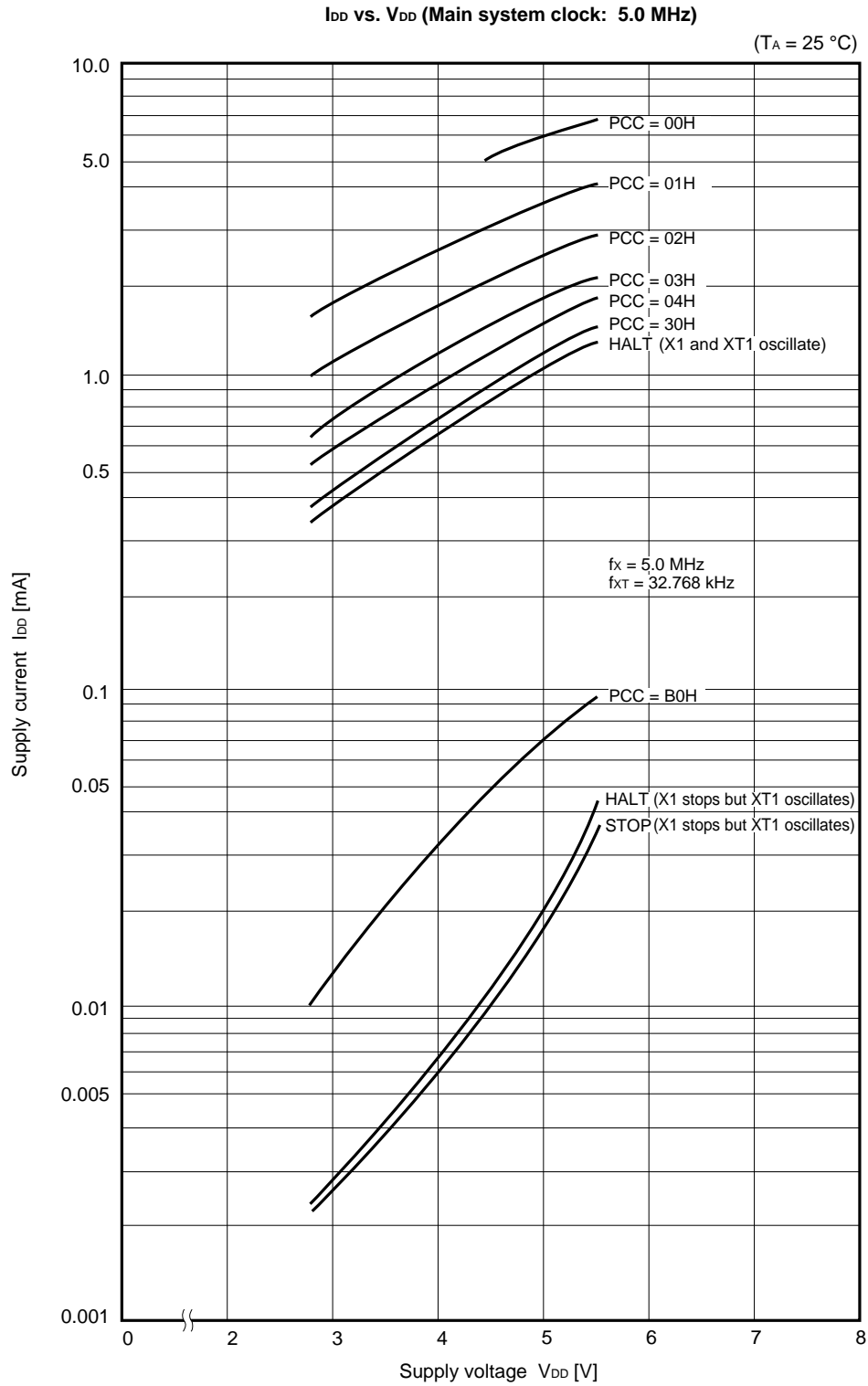

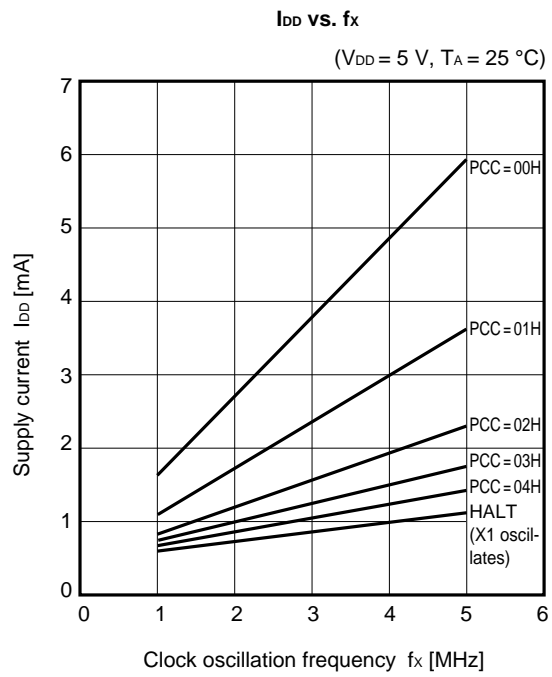
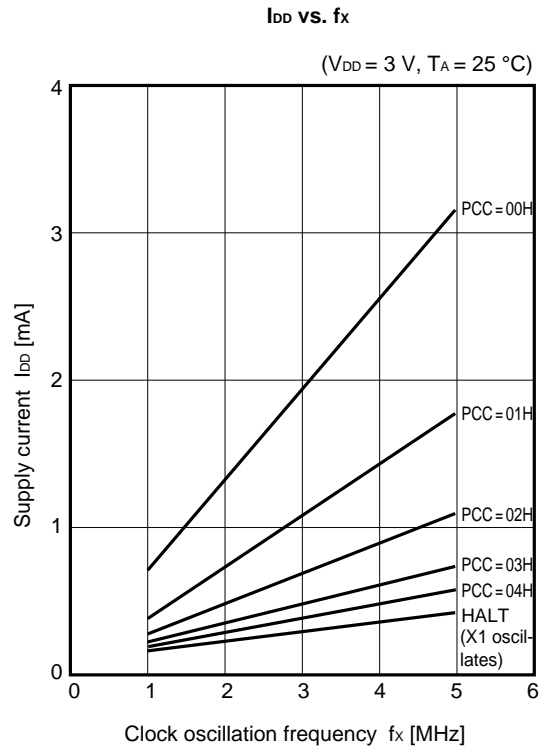

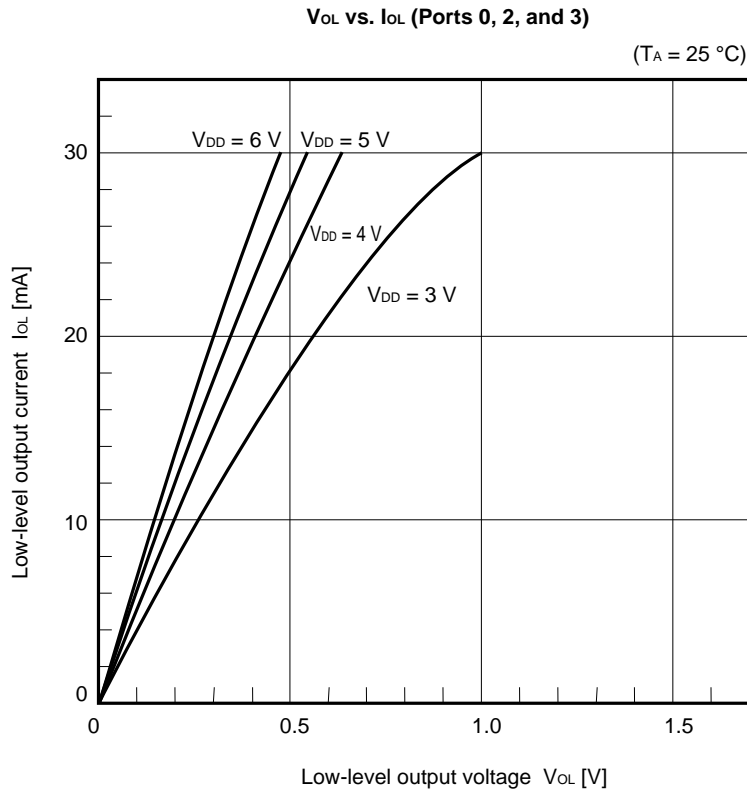
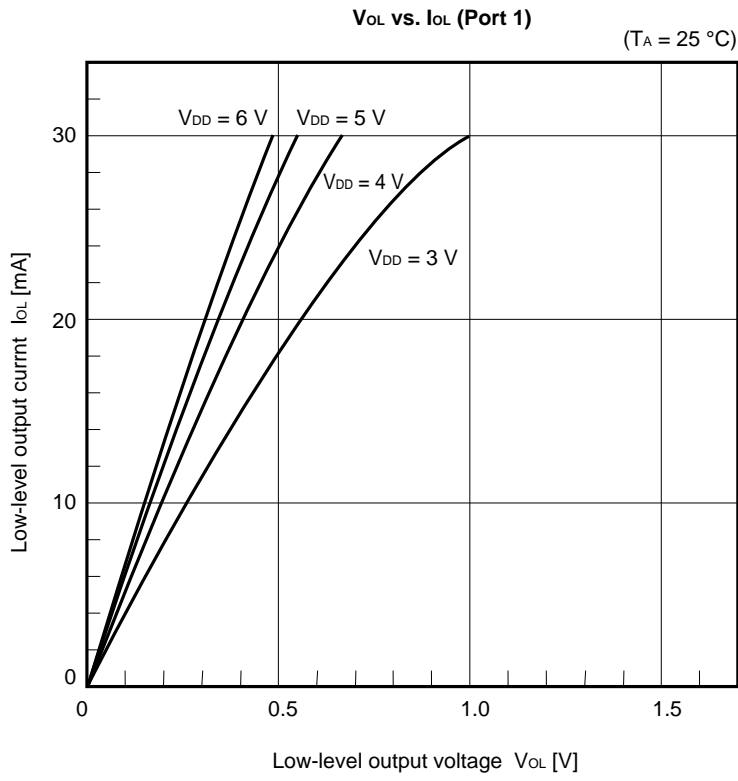

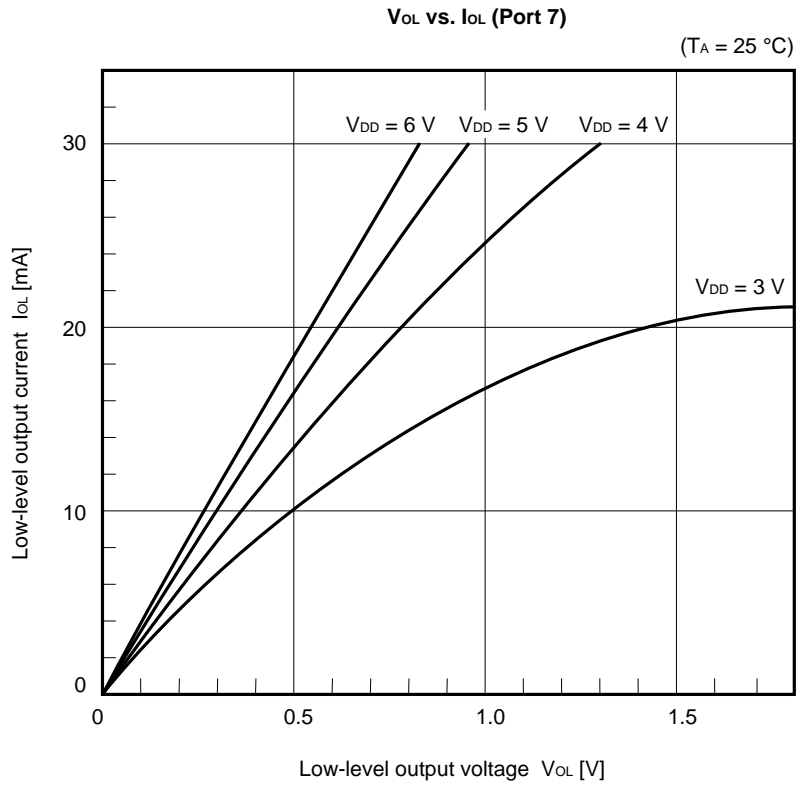

$V_{DD} - V_{OH}$ vs. I_{OH} (Port 0 - Port 3)

($T_A = 25^\circ\text{C}$)

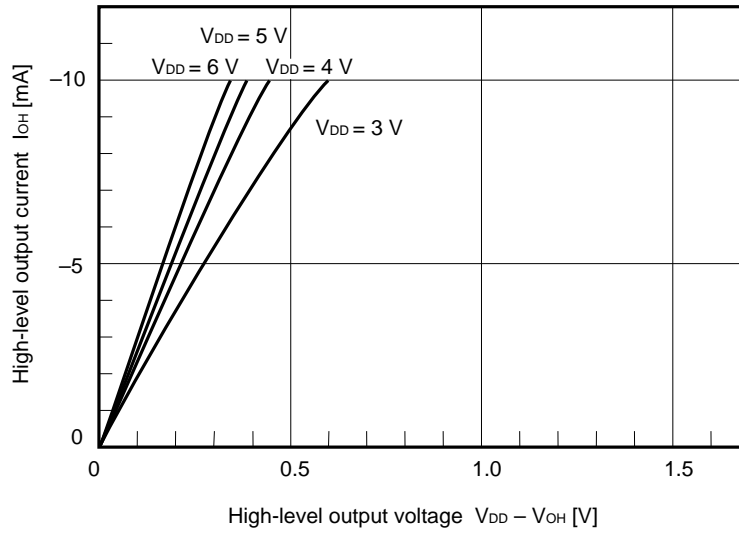

$V_{DD} - V_{OH}$ vs. I_{OH} (Port 8 - Port 12)

($T_A = 25^\circ\text{C}$)

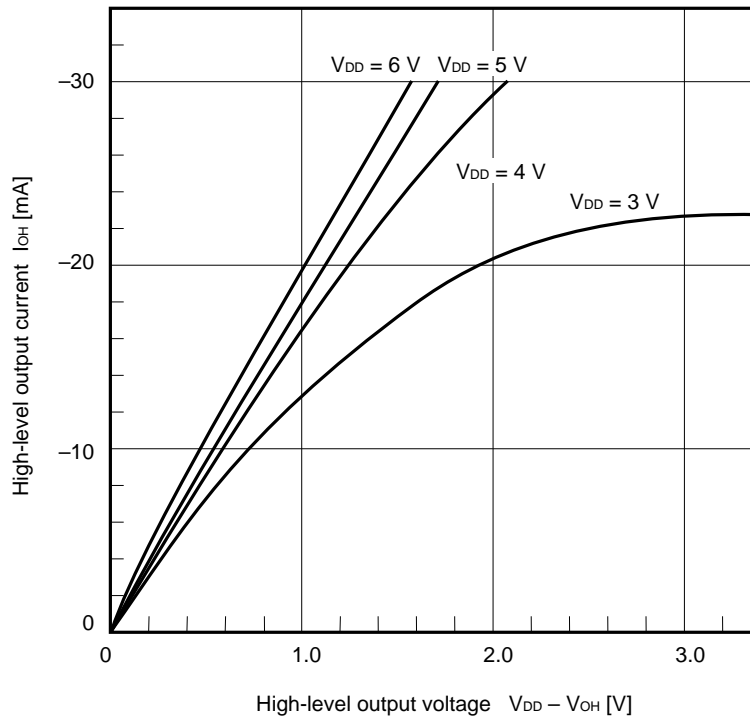

12. PACKAGE DRAWING



80 PIN PLASTIC QFP (14×20)

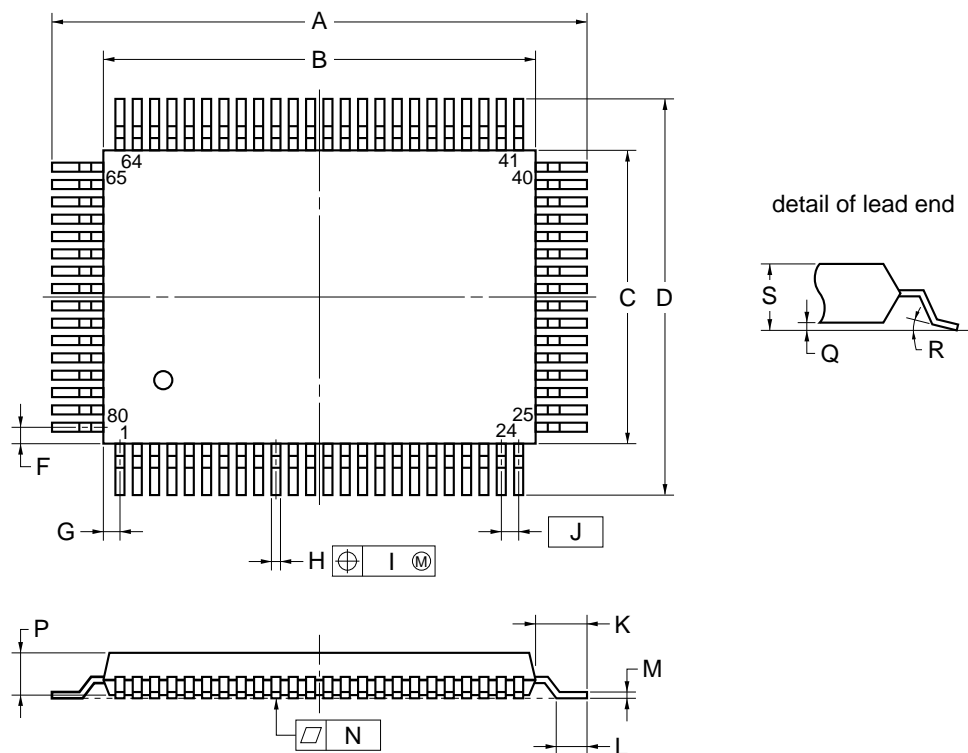

NOTE

Each lead centerline is located within 0.15 mm (0.006 inch) of its true position (T.P.) at maximum material condition.

ITEM	MILLIMETERS	INCHES
A	23.6±0.4	0.929±0.016
B	20.0±0.2	0.795 ^{+0.009} _{-0.008}
C	14.0±0.2	0.551 ^{+0.009} _{-0.008}
D	17.6±0.4	0.693±0.016
F	1.0	0.039
G	0.8	0.031
H	0.35±0.10	0.014 ^{+0.004} _{-0.005}
I	0.15	0.006
J	0.8 (T.P.)	0.031 (T.P.)
K	1.8±0.2	0.071 ^{+0.008} _{-0.009}
L	0.8±0.2	0.031 ^{+0.009} _{-0.008}
M	0.15 ^{+0.10} _{-0.05}	0.006 ^{+0.004} _{-0.003}
N	0.10	0.004
P	2.7	0.106
Q	0.1±0.1	0.004±0.004
R	5°±5°	5°±5°
S	3.0 MAX.	0.119 MAX.

P80GF-80-3B9-3

Remark The shape and material of the ES version are the same as those of the corresponding mass-produced product.

★ 13. RECOMMENDED SOLDERING CONDITIONS

The conditions listed below shall be met when soldering the μPD78042F, μPD78043F, μPD78044F, or μPD78045F.

For details of the recommended soldering conditions, refer to our document *Semiconductor Device Mounting Technology Manual* (C10535E).

Please consult with our sales offices in case any other soldering process is used, or in case soldering is done under different conditions.

Table 13-1 Soldering Conditions for Surface-Mount Devices

μPD78042FGF-xxx-3B9: 80-pin plastic QFP (14 × 20 mm)

μPD78043FGF-xxx-3B9: 80-pin plastic QFP (14 × 20 mm)

μPD78044FGF-xxx-3B9: 80-pin plastic QFP (14 × 20 mm)

μPD78045FGF-xxx-3B9: 80-pin plastic QFP (14 × 20 mm)

Soldering process	Soldering conditions	Recommended conditions
Infrared ray reflow	Peak package's surface temperature: 235 °C Reflow time: 30 seconds or less (210 °C or more) Maximum allowable number of reflow processes: 3	IR35-00-3
VPS	Peak package's surface temperature: 215 °C Reflow time: 40 seconds or less (200 °C or more) Maximum allowable number of reflow processes: 3	VP15-00-3
Wave soldering	Solder temperature: 260 °C or less Flow time: 10 seconds or less Number of flow processes: 1 Preheating temperature : 120 °C max. (measured on the package surface)	WS60-00-1
Partial heating method	Terminal temperature: 300 °C or less Heat time: 3 seconds or less (for one side of a device)	—

Caution Do not apply two or more different soldering methods to one chip (except for partial heating method for terminal sections).

APPENDIX A DEVELOPMENT TOOLS

The following tools are available for development of systems using the μPD78042F, μPD78043F, μPD78044F, or μPD78045F.

Language processing software

RA78K/0 ^{Notes 1, 2, 3, 4}	Assembler package common to 78K/0 series
CC78K/0 ^{Notes 1, 2, 3, 4}	C compiler package common to 78K/0 series
DF78044 ^{Notes 1, 2, 3, 4}	Device file for μPD78044A subseries
CC78K/0-L ^{Notes 1, 2, 3, 4}	C compiler library source file common to 78K/0 series

PROM writing tools

PG-1500	PROM programmer
PA-78P048GF PA-78P048KL-S	Programmer adapter connected to PG-1500
PG-1500 controller ^{Notes 1, 2}	Control program for PG-1500

Debugging tools

IE-78000-R	In-circuit emulator common to 78K/0 series	
IE-78000-R-A ^{Note 8}	In-circuit emulator common to 78K/0 series (for integrated debugger)	★
IE-78000-R-BK	Break board common to 78K/0 series	
IE-78044-R-EM	Emulation board for evaluating μPD78044A subseries	
EP-78130GF-R	Emulation probe common to μPD78134	
EV-9200G-80	Socket mounted on target system created for 80-pin plastic QFP	
SM78K0 ^{Notes 5, 6, 7}	System simulator common to 78K/0 series	
ID78K0 ^{Notes 4, 5, 6, 7, 8}	Integrated debugger for IE-78000-R-A	★
SD78K/0 ^{Notes 1, 2}	Screen debugger for IE-78000-R	
DF78044 ^{Notes 1, 2, 5, 6, 7}	Device file common to μPD78044A subseries	

Real-time OS

RX78K/0 ^{Notes 1, 2, 3, 4}	Real-time OS for 78K/0 series
MX78K0 ^{Notes 1, 2, 3, 4}	OS for 78K/0 series

Notes 1. PC-9800 series (MS-DOS™) based

2. IBM PC/AT™ and compatible (PC DOS™/IBM DOS™/MS-DOS) based

3. HP9000 series 300™ (HP-UX™) based

4. HP9000 series 700™ (HP-UX) based, SPARCstation™ (SunOS™) based, EWS-4800 series (EWS-UX/V) based

5. PC-9800 series (MS-DOS + Windows™) based

6. IBM PC/AT and compatible (PC DOS/IBM DOS/MS-DOS + Windows) based

7. NEWS™ (NEWS-OS™) based

8. Under development

Fuzzy inference development support system

FE9000 ^{Note 1} /FE9200 ^{Note 3}	Fuzzy knowledge data creation tool
FT9080 ^{Note 1} /FT9085 ^{Note 2}	Translator
FI78K0 ^{Notes 1, 2}	Fuzzy inference module
FD78K0 ^{Notes 1, 2}	Fuzzy inference debugger

Notes 1. PC-9800 series (MS-DOS) based

2. IBM PC/AT and compatible (PC DOS/IBM DOS/MS-DOS) based

3. IBM PC/AT and compatible (PC DOS/IBM DOS/MS-DOS + Windows) based

Remarks 1. Please refer to the *78K/0 Series Selection Guide* (U11126E) for information on third party development tools.

2. RA78K/0, CC78K/0, SM78K/0, ID78K0, SD78K/0, and RX78K/0 are used in combination with DF78044.

APPENDIX B RELATED DOCUMENTS

• **Documents Related to Devices**

Document name	Document No.	
	Japanese	English
μPD78044F Sub-Series User's Manual	U10908J	U10908E
μPD78042F, 78043F, 78044F, 78045F Data Sheet	U10700J	This manual
μPD78P048A Data Sheet	U10611J	U10611E
μPD78044A, 78044F Sub-Series Special Function Registers	U10701J	—
78K/0 Series User's Manual, Instruction	IEU-849	IEU-1372
78K/0 Series Instruction Summary Sheet	U10903J	—
78K/0 Series Instruction Set	U10904J	—

• **Documents Related to Development Tools (User's Manual)**

Document name		Document No.	
		Japanese	English
RA78K Series Assembler Package	Operation	EEU-809	EEU-1399
	Language	EEU-815	EEU-1404
RA78K Series Structured Assembler Preprocessor		EEU-817	EEU-1402
CC78K Series C Compiler	Operation	EEU-656	EEU-1280
	Language	EEU-655	EEU-1284
CC78K/0 Compiler Application Note	Programming Know-How	EEA-618	EEA-1208
CC78K Series Library Source File		EEU-777	—
PG-1500 PROM Programmer		EEU-651	EEU-1335
PG-1500 Controller PC-9800 Series (MS-DOS) Base		EEU-704	EEU-1291
PG-1500 Controller IBM PC Series (PC DOS) Base		EEU-5008	U10540E
IE-78000-R		EEU-810	U11376E
IE-78000-R-A		U10057J	U10057E
IE-78000-R-BK		EEU-867	EEU-1427
IE-78044-R-EM		EEU-833	EEU-1424
EP-78130GF-R		EEU-943	EEU-1470
SM78K0 System Simulator	Reference	EEU-5002	U10181E
SM78K Series System Simulator	External Parts User Open Interface Specifications	U10092J	U10092E
ID78K0 Integrated Debugger	Reference	U11151J	—
SD78K/0 Screen Debugger	Tutorial	EEU-852	U10539E
PC-9800 Series (MS-DOS) Base	Reference	EEU-816	—
SD78K/0 Screen Debugger	Tutorial	EEU-5024	EEU-1414
IBM PC/AT (PC DOS) Base	Reference	U11279J	EEU-1413

★

★

Caution The above documents may be revised without notice. Use the latest versions when you design an application system.

• Documents Related to Software to Be Incorporated into the Product (User's Manual)

Document name		Document No.	
		Japanese	English
78K/0 Series Real-Time OS	Basic	EEU-912	—
	Installation	EEU-911	—
	Technical	EEU-913	—
OS for 78K/0 Series MX78K0	Basic	EEU-5010	—
Tool for Creating Fuzzy Knowledge Data		EEU-829	EEU-1438
78K/0, 78K/II, and 87AD Series Fuzzy Inference Development Support System, Translator		EEU-829	EEU-1444
78K/0 Series Fuzzy Inference Development Support System, Fuzzy Inference Module		EEU-858	EEU-1441
78K/0 Series Fuzzy Inference Development Support System, Fuzzy Inference Debugger		EEU-921	EEU-1458

• Other Documents

Document name		Document No.	
		Japanese	English
★ IC PACKAGE MANUAL		C10943X	
SMD Surface Mount Technology Manual		C10535J	C10535E
Quality Grades on NEC Semiconductor Device		IEI-620	IEI-1209
NEC Semiconductor Device Reliability/Quality Control System		C10983J	C10983E
Electrostatic Discharge (ESD) Test		MEM-539	—
Guide to Quality Assurance for Semiconductor Device		MEI-603	MEI-1202
Guide for Products Related to Micro-Computer: Other Companies		MEI-604	—

Caution The above documents may be revised without notice. Use the latest versions when you design an application system.

[MEMO]

Cautions on CMOS Devices **Countermeasures against static electricity for all MOSs**

Caution When handling MOS devices, take care so that they are not electrostatically charged.

Strong static electricity may cause dielectric breakdown in gates. When transporting or storing MOS devices, use conductive trays, magazine cases, shock absorbers, or metal cases that NEC uses for packaging and shipping. Be sure to ground MOS devices during assembling. Do not allow MOS devices to stand on plastic plates or do not touch pins.

Also handle boards on which MOS devices are mounted in the same way.

 **CMOS-specific handling of unused input pins**

Caution Hold CMOS devices at a fixed input level.

Unlike bipolar or NMOS devices, if a CMOS device is operated with no input, an intermediate-level input may be caused by noise. This allows current to flow in the CMOS device, resulting in a malfunction. Use a pull-up or pull-down resistor to hold a fixed input level. Since unused pins may function as output pins at unexpected times, each unused pin should be separately connected to the V_{DD} or GND pin through a resistor.

If handling of unused pins is documented, follow the instructions in the document.

 **Statuses of all MOS devices at initialization**

Caution The initial status of a MOS device is unpredictable when power is turned on.

Since characteristics of a MOS device are determined by the amount of ions implanted in molecules, the initial status cannot be determined in the manufacture process. NEC has no responsibility for the output statuses of pins, input and output settings, and the contents of registers at power on. However, NEC assures operation after reset and items for mode setting if they are defined.

When you turn on a device having a reset function, be sure to reset the device first.

FIP is a trademark of NEC Corporation.

IEBus is trademark of NEC Corporation.

MS-DOS and Windows are trademarks of Microsoft Corporation.

IBM DOS, PC/AT, and PC DOS are trademarks of IBM Corporation.

HP9000 series 300, HP9000 series 700, and HP-UX are trademarks of Hewlett-Packard.

SPARCstation is a trademark of SPARC International, Inc.

SunOS is a trademark of Sun Microsystems, Inc.

NEWS and NEWS-OS are trademarks of SONY Corporation.

Regional Information

Some information contained in this document may vary from country to country. Before using any NEC product in your application, please contact the NEC office in your country to obtain a list of authorized representatives and distributors. They will verify:

- Device availability
- Ordering information
- Product release schedule
- Availability of related technical literature
- Development environment specifications (for example, specifications for third-party tools and components, host computers, power plugs, AC supply voltages, and so forth)
- Network requirements

In addition, trademarks, registered trademarks, export restrictions, and other legal issues may also vary from country to country.

NEC Electronics Inc. (U.S.)

Mountain View, California
Tel: 800-366-9782
Fax: 800-729-9288

NEC Electronics (Germany) GmbH

Duesseldorf, Germany
Tel: 0211-65 03 02
Fax: 0211-65 03 490

NEC Electronics (UK) Ltd.

Milton Keynes, UK
Tel: 01908-691-133
Fax: 01908-670-290

NEC Electronics Italiana s.r.l.

Milano, Italy
Tel: 02-66 75 41
Fax: 02-66 75 42 99

NEC Electronics (Germany) GmbH

Benelux Office
Eindhoven, The Netherlands
Tel: 040-2445845
Fax: 040-2444580

NEC Electronics (France) S.A.

France
Tel: 01-30-67 58 00
Fax: 01-30-67 58 99

NEC Electronics (France) S.A.

Spain Office
Madrid, Spain
Tel: 01-504-2787
Fax: 01-504-2860

NEC Electronics (Germany) GmbH

Scandinavia Office
Taeby Sweden
Tel: 8-63 80 820
Fax: 8-63 80 388

NEC Electronics Hong Kong Ltd.

Hong Kong
Tel: 2886-9318
Fax: 2886-9022/9044

NEC Electronics Hong Kong Ltd.

Seoul Branch
Seoul, Korea
Tel: 02-528-0303
Fax: 02-528-4411

NEC Electronics Singapore Pte. Ltd.

United Square, Singapore 1130
Tel: 253-8311
Fax: 250-3583

NEC Electronics Taiwan Ltd.

Taipei, Taiwan
Tel: 02-719-2377
Fax: 02-719-5951

NEC do Brasil S.A.

Sao Paulo-SP, Brasil
Tel: 011-889-1680
Fax: 011-889-1689

Note that "preliminary" is not indicated in this document, even though the related documents may be preliminary versions.

The export of this product from Japan is regulated by the Japanese government. To export this product may be prohibited without governmental license, the need for which must be judged by the customer. The export or re-export of this product from a country other than Japan may also be prohibited without a license from that country. Please call an NEC sales representative.

No part of this document may be copied or reproduced in any form or by any means without the prior written consent of NEC Corporation. NEC Corporation assumes no responsibility for any errors which may appear in this document.

NEC Corporation does not assume any liability for infringement of patents, copyrights or other intellectual property rights of third parties by or arising from use of a device described herein or any other liability arising from use of such device. No license, either express, implied or otherwise, is granted under any patents, copyrights or other intellectual property rights of NEC Corporation or others.

While NEC Corporation has been making continuous effort to enhance the reliability of its semiconductor devices, the possibility of defects cannot be eliminated entirely. To minimize risks of damage or injury to persons or property arising from a defect in an NEC semiconductor device, customer must incorporate sufficient safety measures in its design, such as redundancy, fire-containment, and anti-failure features.

NEC devices are classified into the following three quality grades:

"Standard", "Special", and "Specific". The Specific quality grade applies only to devices developed based on a customer designated "quality assurance program" for a specific application. The recommended applications of a device depend on its quality grade, as indicated below. Customers must check the quality grade of each device before using it in a particular application.

Standard: Computers, office equipment, communications equipment, test and measurement equipment, audio and visual equipment, home electronic appliances, machine tools, personal electronic equipment and industrial robots

Special: Transportation equipment (automobiles, trains, ships, etc.), traffic control systems, anti-disaster systems, anti-crime systems, safety equipment and medical equipment (not specifically designed for life support)

Specific: Aircrafts, aerospace equipment, submersible repeaters, nuclear reactor control systems, life support systems or medical equipment for life support, etc.

The quality grade of NEC devices in "Standard" unless otherwise specified in NEC's Data Sheets or Data Books. If customers intend to use NEC devices for applications other than those specified for Standard quality grade, they should contact NEC Sales Representative in advance.

Anti-radioactive design is not implemented in this product.