

STK6972

Thick Film Hybrid Integrated Circuit

BRIDGE POWER PACK

TENTATIVE

General Description

The STK6970 series are small-sized hybrid IC's fabricated using the SC (Substrate Carrier) System which is a new manufacturing technique for small-sized hybrid IC's with our original IMST (Insulated Metal Substrate Technology) substrate. They contain 2-channel bridge power in a single package and have the following functions: forward/reverse rotation, speed control, braking of DC motors. They are especially suited for use in controlling reel motors, loading motors of VTR's and also in driving DC motors of various types.

Features

- . Linear output proportional to input voltage
- . Brake function available at input open mode
- . Brake function available at the time of simultaneous application of input for forward/reverse rotation
- . Brake function available at forward rotation mode
- . Wide operating supply voltage (3V to 24V)
- . High current gain (ex. 1A typ. for 0.25mA)
- . Excellent stability of output voltage in intermediate region
- . Small current dissipation at braking mode

Application Areas

- . Forward/reverse rotation of DC motors (VTR's, VD's, printers)
- . Forward rotation (with brake function) of DC motors

Maximum Ratings at $T_a=25^\circ\text{C}$

				unit
Supply Voltage	V_{CC}	Quiescent	25	V
Input Applied Voltage	V_{in}		25	V
Output Current	I_C		2.0	A
Power Dissipation	P_d^*1	$T_C=25^\circ\text{C}$	7.5	W
Storage Temperature	T_{stg}		-40 to +125	$^\circ\text{C}$
Operating Case Temperature	T_C		100	$^\circ\text{C}$
Junction Temperature	T_j		150	$^\circ\text{C}$

*1 P_d : Value for each of TR3, TR6, TR9, TR13

Operating Characteristics at $T_a=25^\circ\text{C}, V_{CC}=12\text{V}, R_L=10\text{ohm/CH}$

			min	typ	max	unit
Quiescent Current	I_{CCO}	$V_{in}=\text{open}$	18	23	30	mA
Input Current - 1	I_{i-1}	$I_o=0.5\text{A}$		170	350	μA
Input Current - 2	I_{i-2}	$I_o=0.9\text{A}, V_{in}=12\text{V}$	0.34	0.7		mA
Input Voltage	V_i	$I_{out}=0.5\text{A}$	6.45	7.2		V
Output Saturation Voltage - 1	V_{st-1}	$I_{in}=1\text{mA}, V_{in}=12\text{V}$	1.37	2.0		V
Output Saturation Voltage - 2	V_{st-2}	$I_{in}=1\text{mA}, V_{in}=12\text{V}$	0.40	1.0		V
Diode Forward Voltage	V_{df}	$I_f=1\text{A}$	1.20	1.8		V

Information furnished by SANYO is believed to be accurate and reliable. However, no responsibility is assumed by SANYO for its use; nor for any infringements of patents or other rights of third parties which may result from its use, and no license is granted by implication or otherwise under any patent or patent rights of SANYO.

These specifications are subject to change without notice.

TOKYO SANYO ELECTRIC CO., LTD. SEMICONDUCTOR DIVISION
5-13, 5-CHOME, SOTOKANDA, CHIYODA-KU, TOKYO 101, JAPAN

6063KI/TS STK6972-1/3

Equivalent Circuit

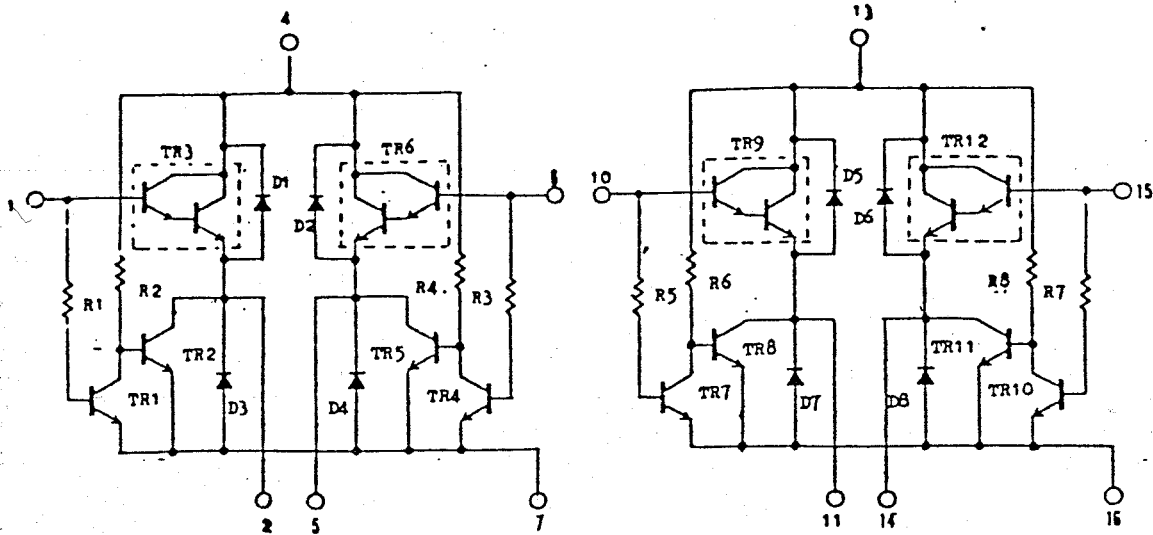

Test Circuit

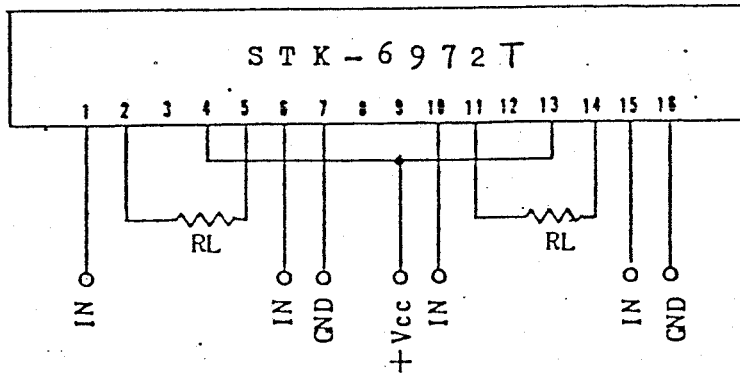

4-1) I_{cc}

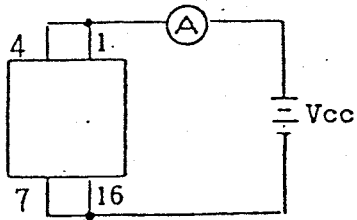

4-2) I_{i-1}, I_{i-2}, V_i

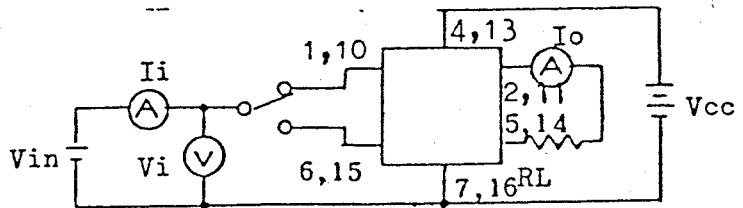

4-3) V_{st-1}, V_{st-2}

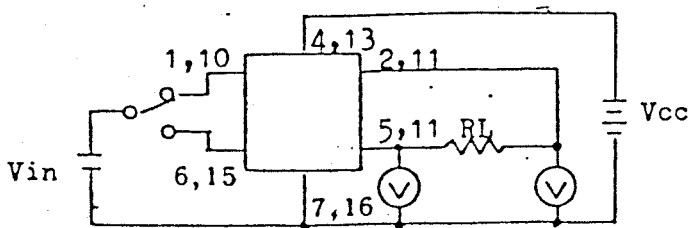

4-3) V_{Df}

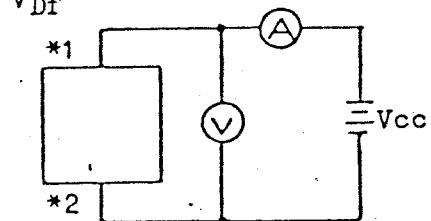

Anode Cathode
 *1 2,5,11,14 → Vcc
 *2 Gnd - 2,5,11,14

Case Outline

unit:mm

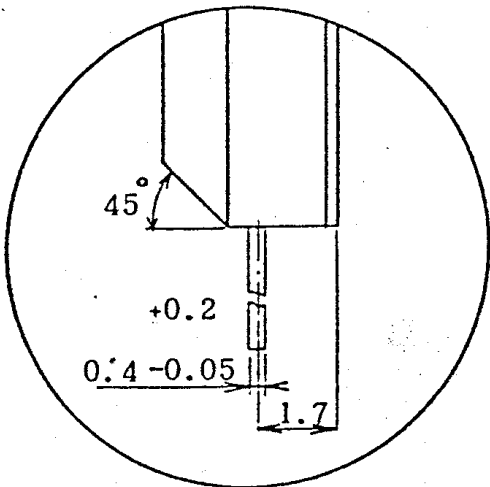
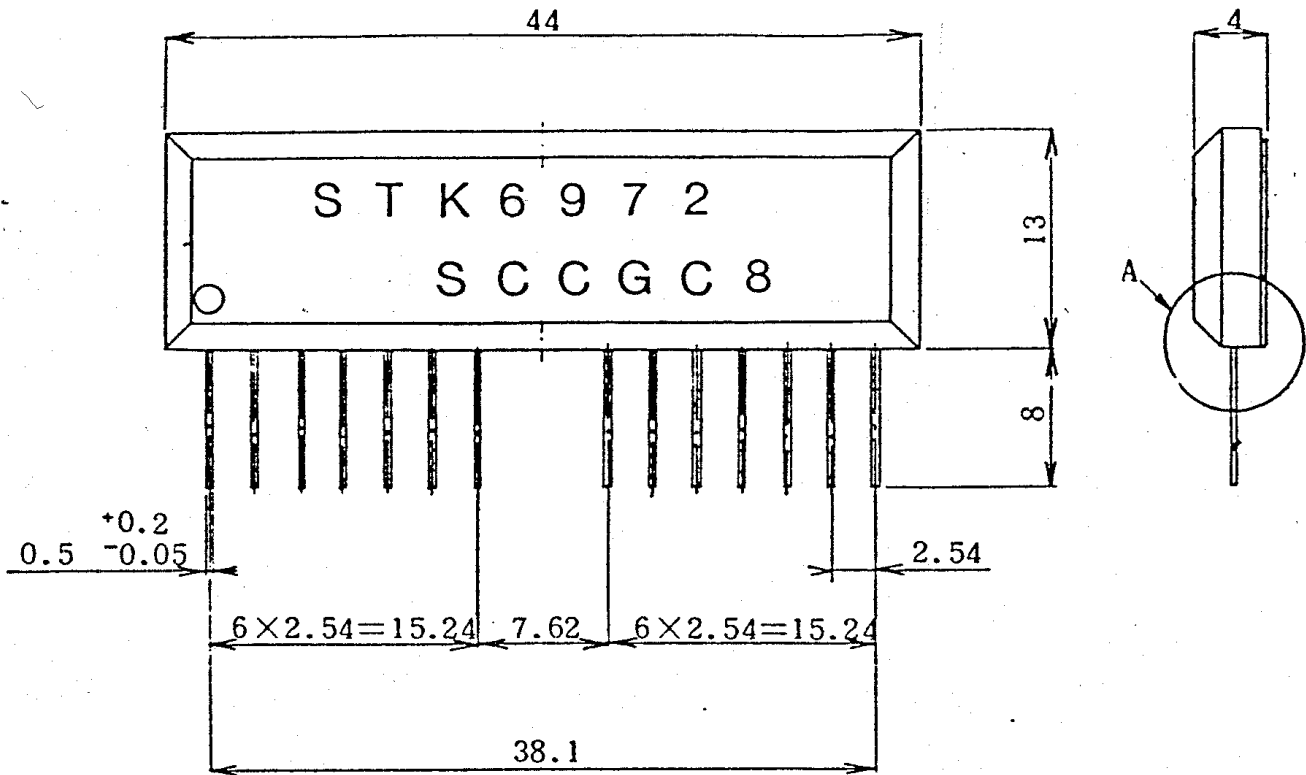

Detail drawing of A