

System Reset (with battery back-up) Monolithic IC MM1026, 1245, 1080 ,1134

Outline

These ICs protect S-RAM data in back-up mode (CS signal makes R-SAM CE pin low and \overline{CE} pin high) when power supply voltage goes below a certain set voltage (detection voltage 3.5V, 4.2V or 4.5V typ.). Further, it switches from main power supply to battery back-up when power supply voltage drops. Conversely, when power supply rises, it first switches the S-RAM from battery back-up to main power supply (switching voltage 3.3V typ.), then from back-up mode to normal mode (CS signal makes S-RAM CE pin high and CE pin low). These signal processes provide reliable protection against data damage.

Features

MM1026

- Power supply switching circuit (switching between main power supply and battery)
- CS control for S-RAM (normal mode : S-RAM can be accessed; back-up mode: S-RAM can not be accessed low current consumption mode)
- Reset output

MM1245

- Power supply switching circuit
- CS control for S-RAM
- CS control signal delay, power supply line chattering removal approx. 1S max.
- Supply current from main power supply can be increased by external power transistor

MM1080

- Power supply switching circuit
- CS control for S-RAM
- Low current consumption 60 μ A typ.

MM1134

- Power supply switching circuit
- CS control for S-RAM
- Gate circuit with CS signal

Characteristics

| | | |
|---|---|------------------|
| 1. Battery back-up | | |
| 1. Low IC current consumption (loss current) | | 0.3 μ A typ. |
| 2. Drop voltage inside IC (input/output voltage difference) | $I_o=100\mu A$ | 0.3V typ. |
| 3. Reverse current (reverse leak current) | | 0.1 μ A max. |
| 2. Normal operation | | |
| 1. Drop voltage inside IC (input/output voltage difference) | $I_o=50\mu A$ | 0.2V typ. |
| 2. Output voltage $V_{CC}=5V$ | $I_o=50mA$ | 4.8V typ. |
| 3. Battery- V_{CC} switching voltage | | 3.3V typ. |
| 4. Detection voltage (CS, \overline{CS} , reset output) | A : 3.5V typ. B : 4.2V typ. C : 4.5V typ. | |

Package

DIP-8B (MM××××□ D)

SOP-8C (MM××××□ F)

*□ contains detection voltage rank.

Applications

1. Memory cards (S-RAM cards)
2. PCs, word processors
3. Fax machines, photocopiers, other office equipment
4. Sequence controllers, other FA equipment
5. Video games and other equipment with S-RAMs

Pin Assignment

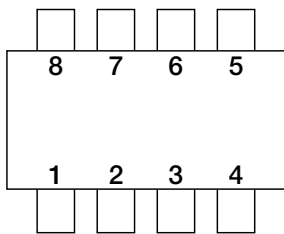

DIP-8P(C)/SOP-8P(C)/SOP-8P(C) Taping

| Pin no. | Pin name | | | |
|---------|-------------------|-------------------|-------------------|-------------------|
| | MM1026 | MM1245 | MM1080 | MM1134 |
| 1 | GND | GND | GND | GND |
| 2 | RESET | T _c | NC | RESET |
| 3 | CS | CS | CS | CS |
| 4 | V _{BATT} | V _{BATT} | V _{BATT} | V _{BATT} |
| 5 | CS | CS | NC | CS |
| 6 | V _{OUT} | V _{OUT} | V _{OUT} | V _{OUT} |
| 7 | NC | Tr.B | NC | Y |
| 8 | V _{CC} | V _{CC} | V _{CC} | V _{CC} |

Block Diagram

MM1026

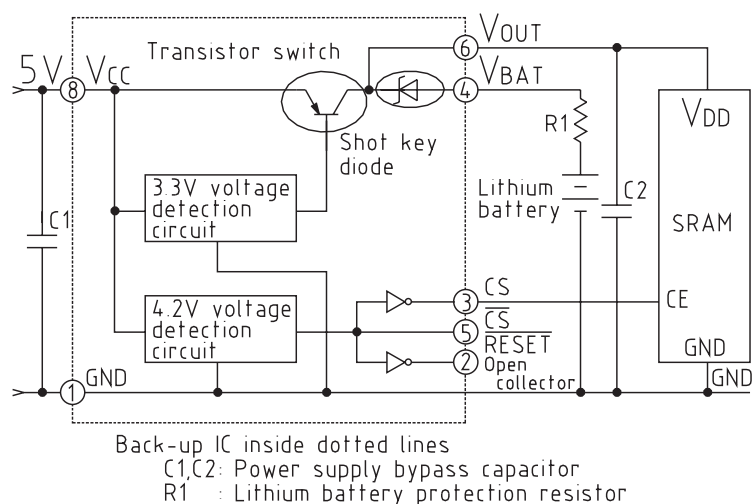

MM1245

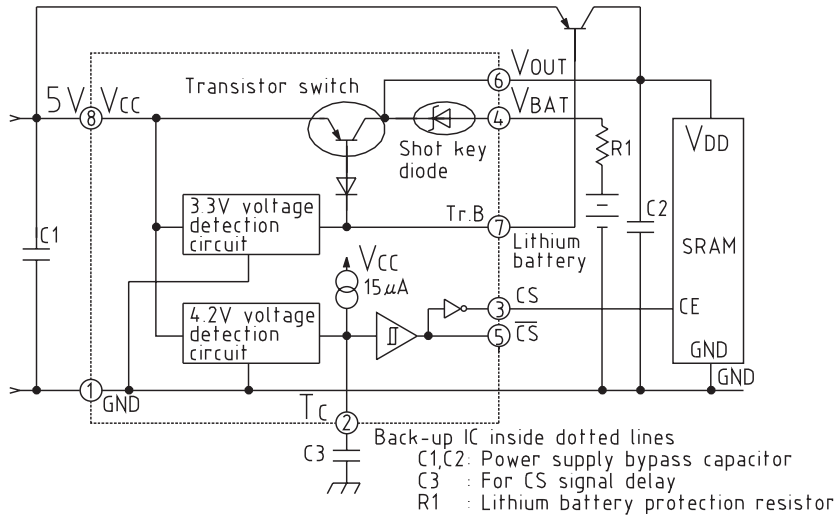

MM1080

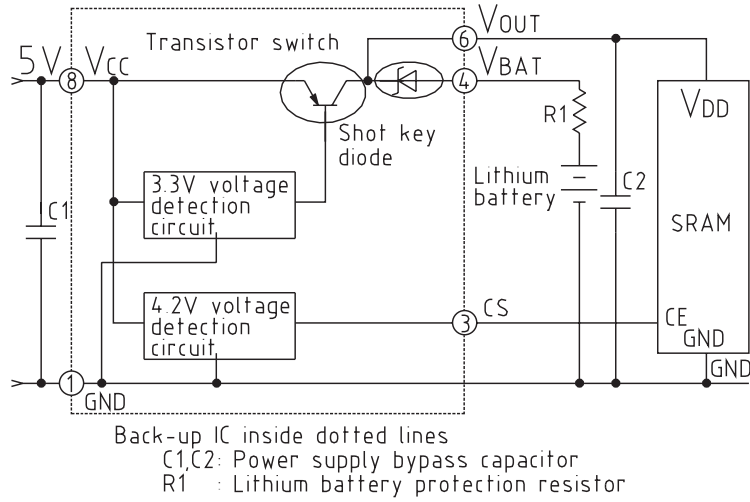

MM1134

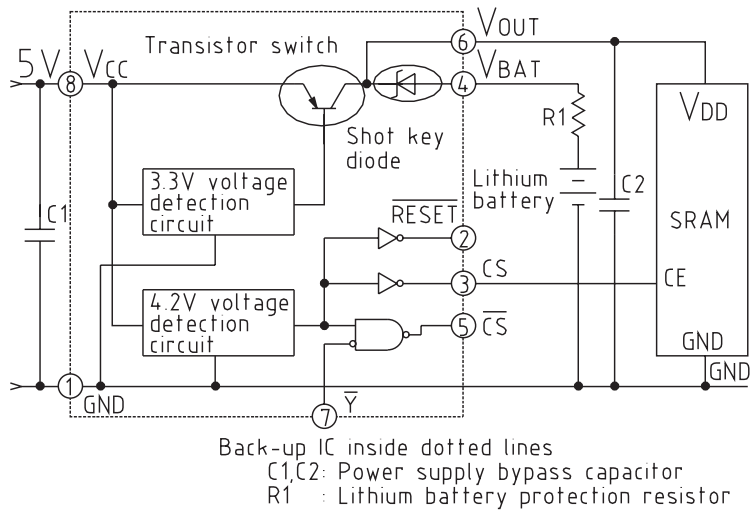

Equivalent Circuit Diagram

MM1026

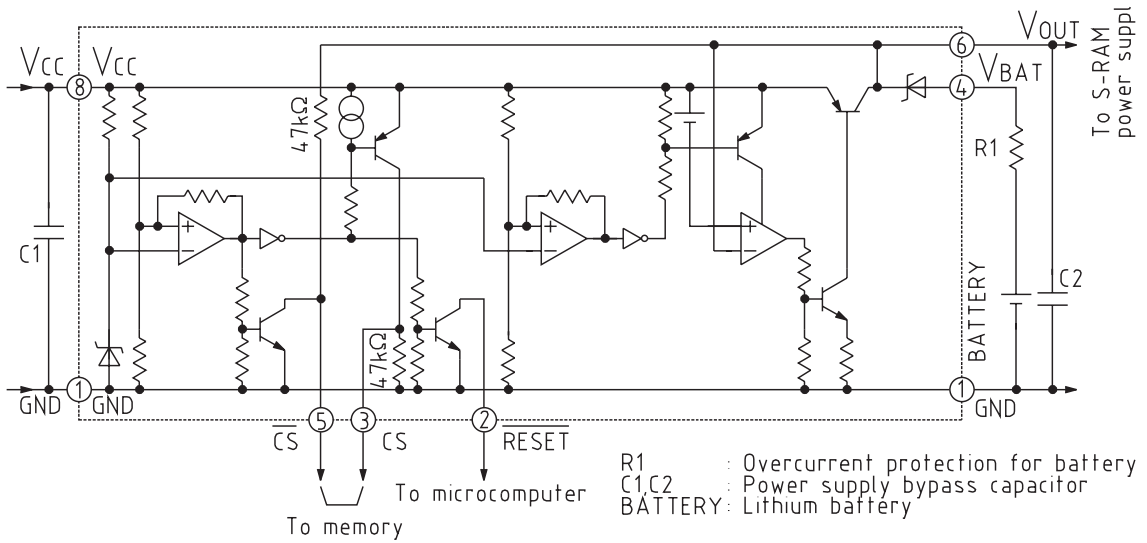

MM1245

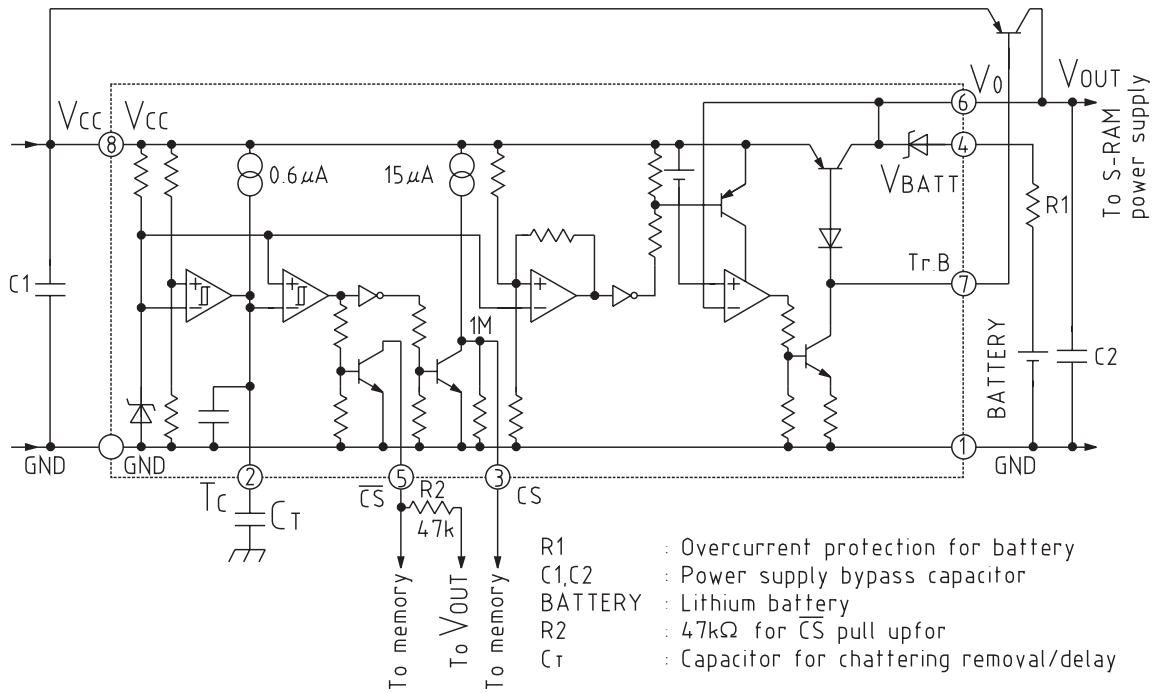

MM1080

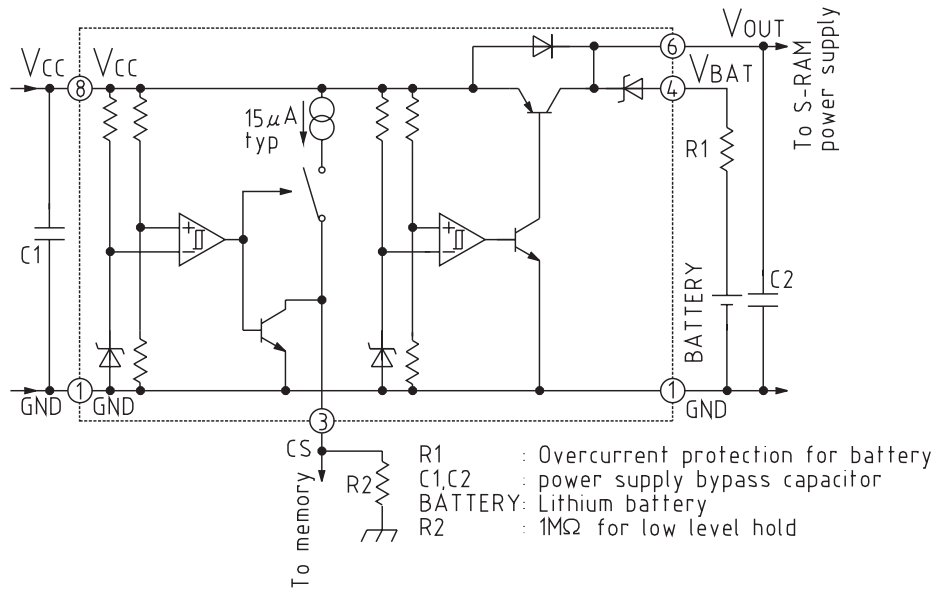

MM1134

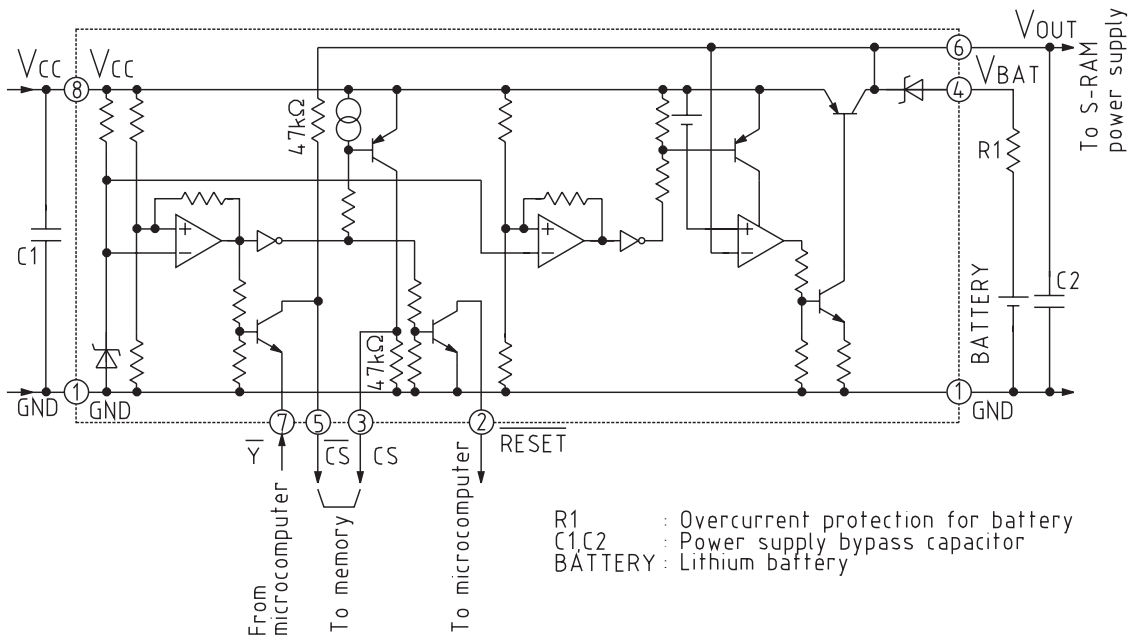

Absolute Maximum Ratings (Ta=25°C)

| Item | Symbol | Rating | Units | |
|-----------------------|----------------------------|-----------------|-------|----|
| Storage temperature | T _{STG} | -40~+125 | °C | |
| Operating temperature | T _{OPR} | -20~+75 | °C | |
| Power supply voltage | V _{CC max.} | 7 | V | |
| Operating voltage | V _{CCOP} | 7 | V | |
| Allowable loss | P _d | 300 | mW | |
| Output current | MM1245 MM1026 MM1134 | I _{o1} | 80 | mA |
| | MM1080 | | 50 | mA |
| | I _{o2} | | 200 | µA |

Note : I_{o1} expresses V_{CC} output current value, and I_{o2} expresses V_{BATT} output current value.

Timing Chart

MM1026

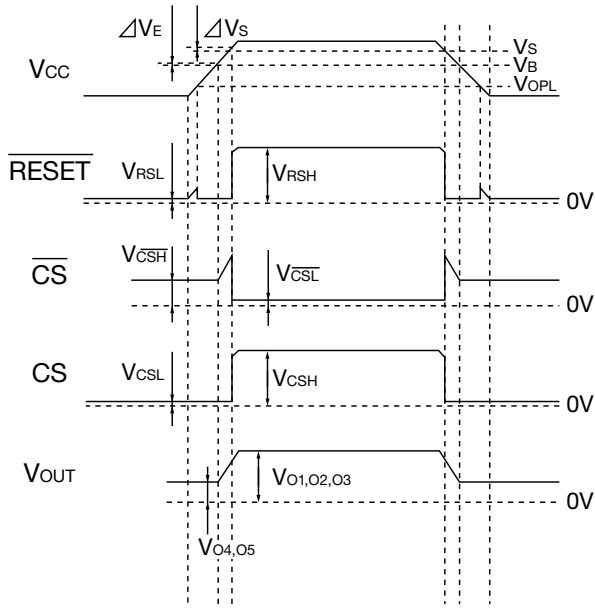

MM1245

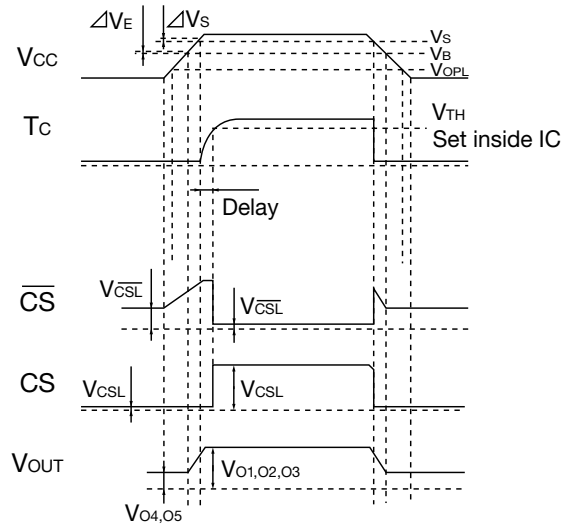

MM1080

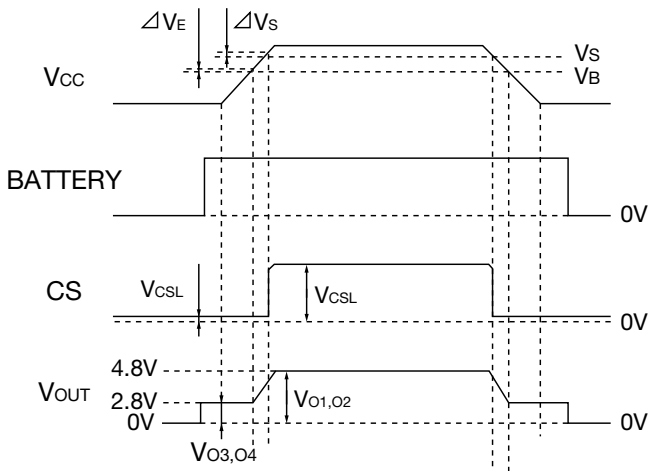

MM1134

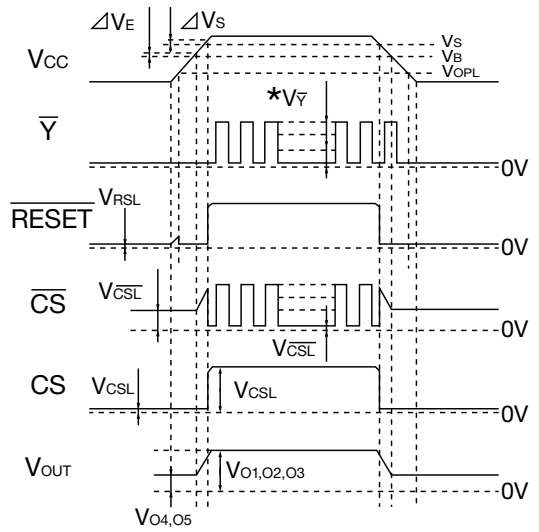

* Use \bar{Y} pin input voltage at less than 5V when $V_{CC} \leq V_s$.

Characteristics (MM1026, MM1134 series)

VOUT-IOUT (VCC=5.0V)

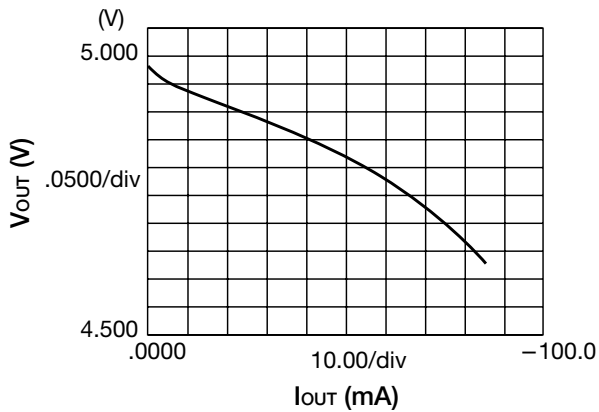

VOUT-IOUT (VBAT=3.0V)

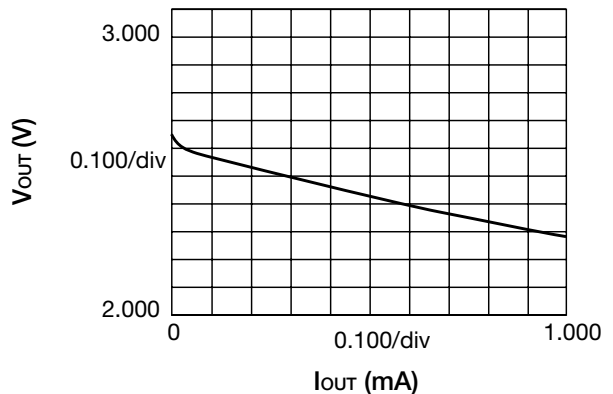

■ V_{CC}-I_{BAT}

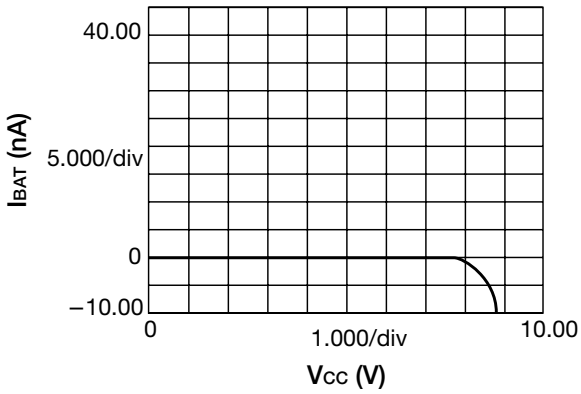

■ V_{CC}-I_{CC}

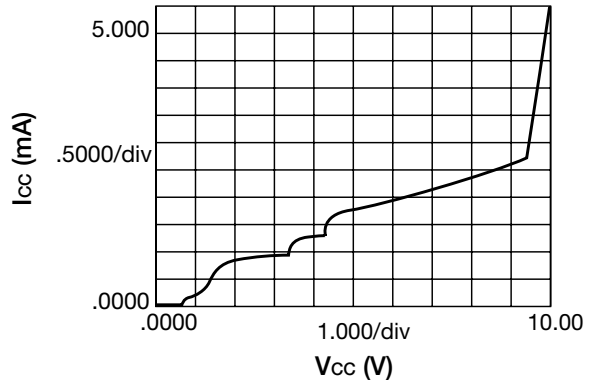

■ Current consumption-Temperature characteristics

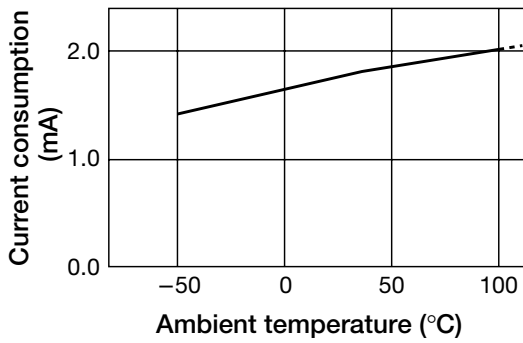

■ Output voltage 1, 2-Temperature characteristics

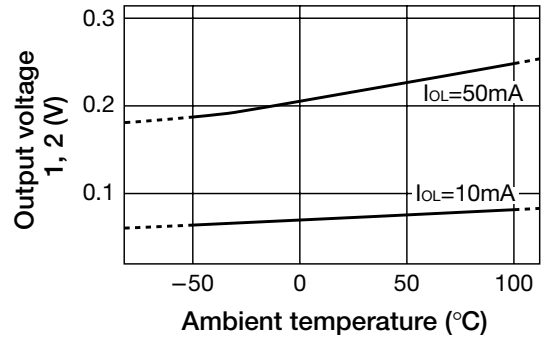

■ Output voltage 3, 4-Temperature

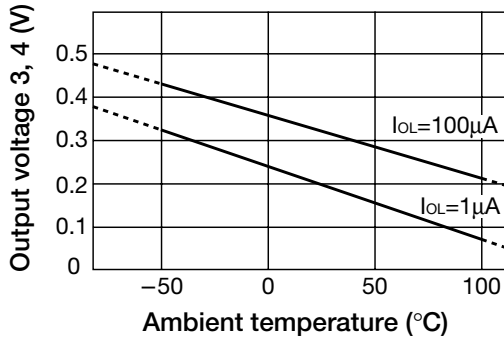

■ Reverse current-Temperature

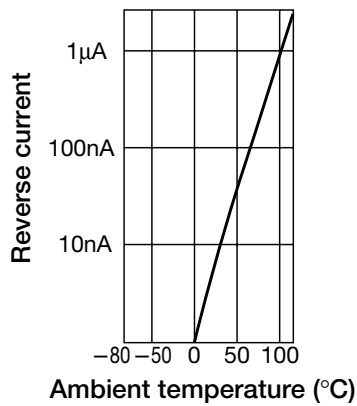

■ Loss current-Temperature

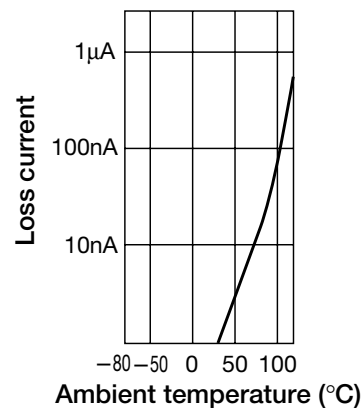

Characteristics (MM1080 series)

Current consumption-Temperature (Vcc=5V)

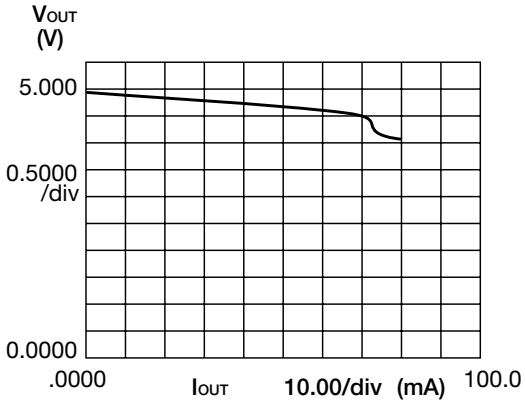

VIN-IIN

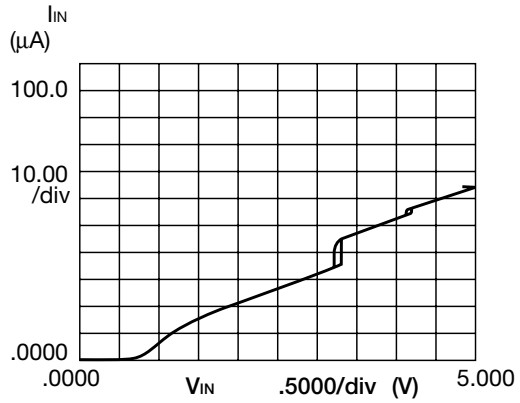

VOUT-IOUT (VBAT=3.0V)

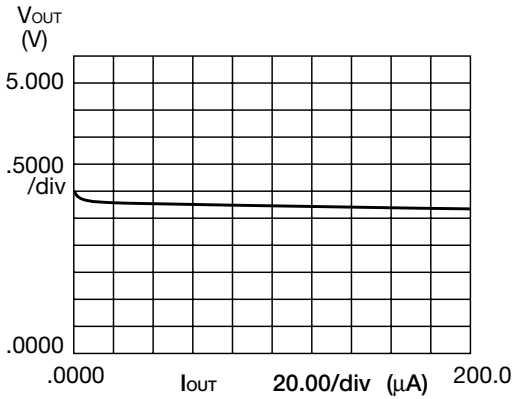

VIN-IBATT

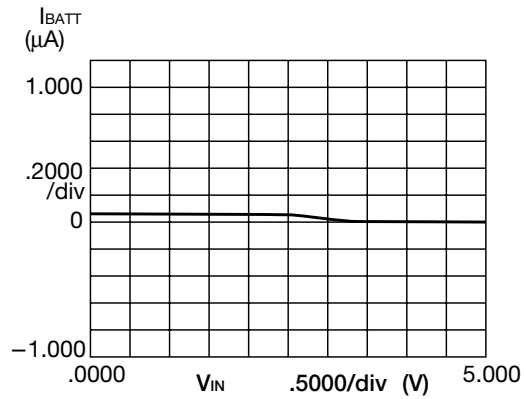

Current consumption-Temperature (VCC=5V)

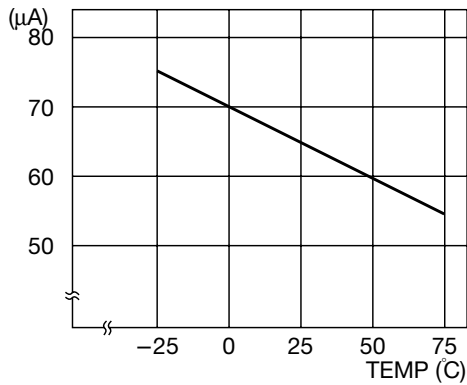

V_{BAT} detection voltage-Temperature

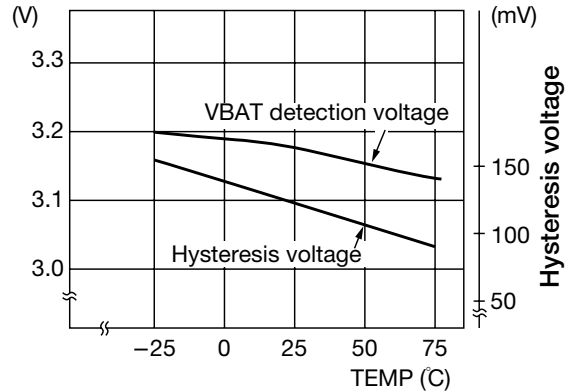

CS detection voltage-Temperature

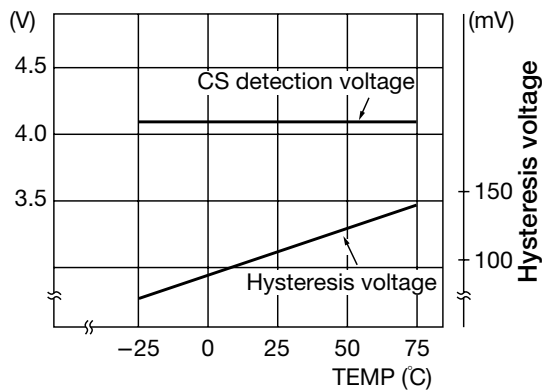

Characteristics (MM1245 series)

I_{OUT}-V_{OUT}

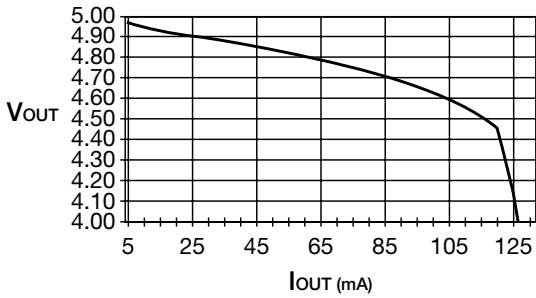

Current consumption-Temperature

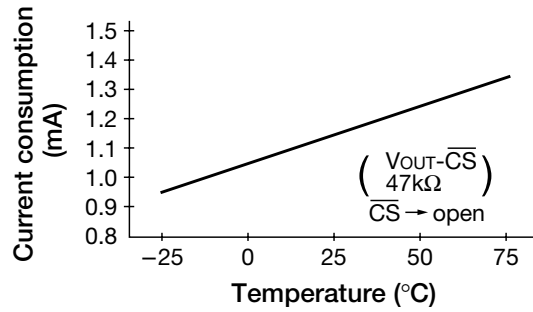

CS detection voltage-Temperature

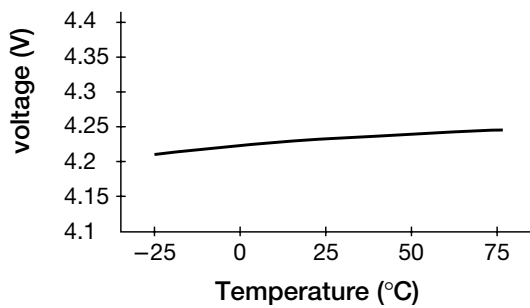

CS-CS pin ON/OFF delay time vs. capacitance TC

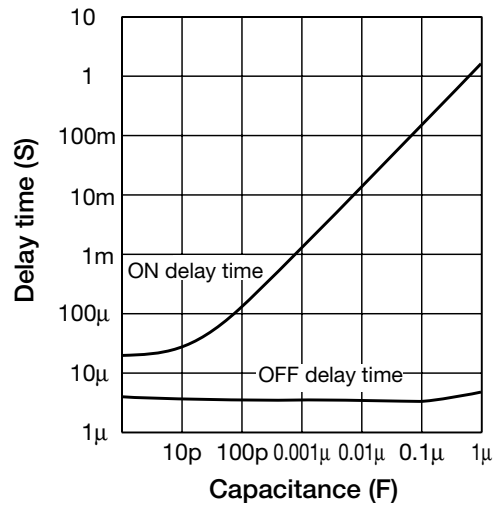

Use 1S max. for CS- \overline{CS} pin ON delay time.

V_{BAT} detection voltage-Temperature

