

# 13-input NAND Gate

# FAST 74F133

**FAST Products**

**PRODUCT SPECIFICATION**

TYPE	TYPICAL PROPAGATION DELAY	TYPICAL SUPPLY CURRENT (TOTAL)
74F133	4.0ns	2.0 mA

**ORDERING INFORMATION**

DESCRIPTION	ORDER CODE	
	COMMERCIAL RANGE $V_{CC} = 5V \pm 10\%$ , $T_{amb} = 0^{\circ}C \text{ to } +70^{\circ}C$	INDUSTRIAL RANGE $V_{CC} = 5V \pm 10\%$ , $T_{amb} = -40^{\circ}C \text{ to } +85^{\circ}C$
16-pin plastic DIP	N74F133N	I74F133N
16-pin plastic SO	N74F133D	I74F133D

**INPUT AND OUTPUT LOADNG AND FAN OUT TABLE**

PINS	DESCRIPTION	74F (U.L.) HIGH/LOW	LOAD VALUE HIGH/LOW
D <sub>0</sub> - D <sub>12</sub>	Data inputs	1.0/1.0	20μA/0.6mA
$\bar{Q}$	Data output	50/33	1.0mA/20mA

**Note to input and output loading and fan out table**

1. One (1.0) FAST unit load is defined as: 20μA in the high state and 0.6mA in the low state.

**PIN CONFIGURATION**

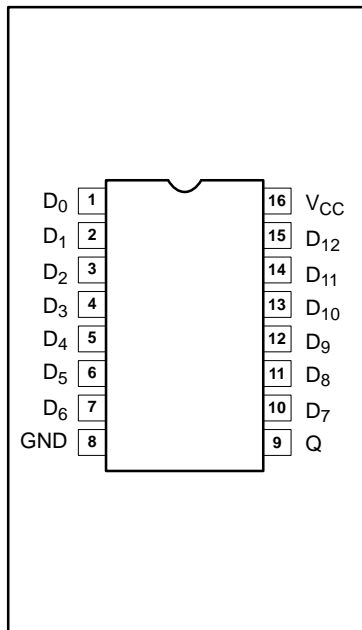

**LOGIC SYMBOL**

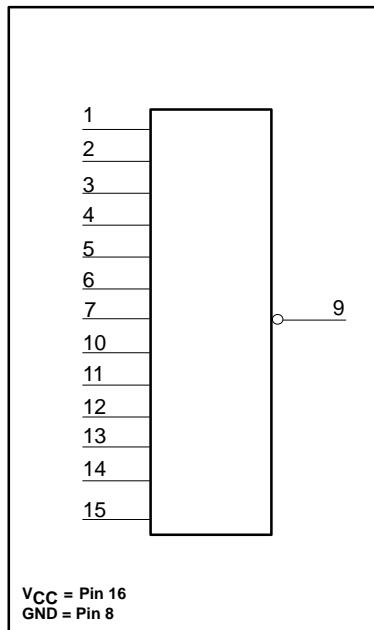

**LOGIC SYMBOL (IEEE/IEC)**

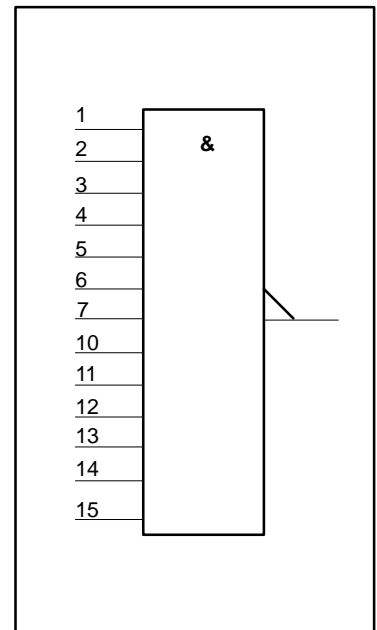

# 13-input NAND Gate

# FAST 74F133

## LOGIC DIAGRAM

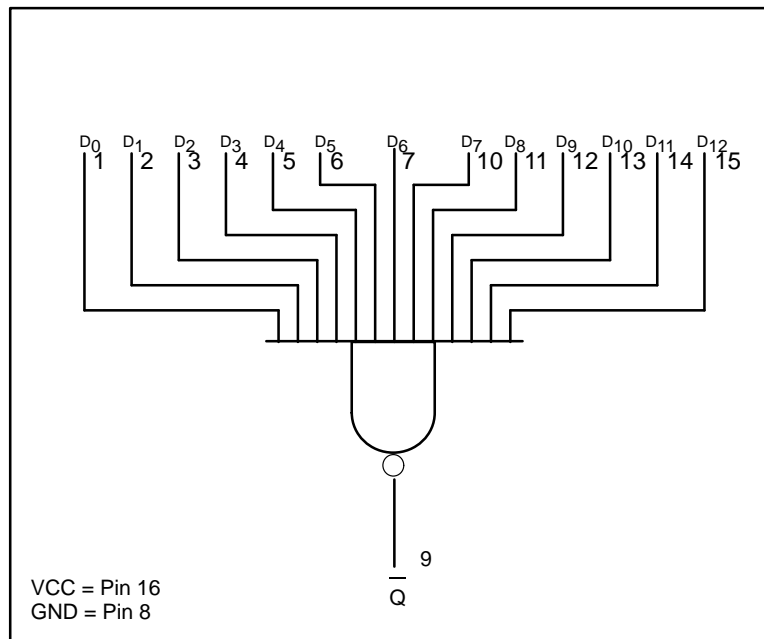

## FUNCTION TABLE

INPUTS													OUTPUT
D0	D1	D2	D3	D4	D5	D6	D7	D8	D9	D10	D11	D12	$\bar{Q}$
H	H	H	H	H	H	H	H	H	H	H	H	H	L
Any one input = L													H

## 13-input NAND Gate

## FAST 74F133

**ABSOLUTE MAXIMUM RATINGS**

(Operation beyond the limit set forth in this table may impair the useful life of the device. Unless otherwise noted these limits are over the operating free air temperature range.)

SYMBOL	PARAMETER		RATING	UNIT
V <sub>CC</sub>	Supply voltage		-0.5 to +7.0	V
V <sub>IN</sub>	Input voltage		-0.5 to +7.0	V
I <sub>IN</sub>	Input current		-30 to +5	mA
V <sub>OUT</sub>	Voltage applied to output in high output state		-0.5 to V <sub>CC</sub>	V
I <sub>OUT</sub>	Current applied to output in low output state		40	mA
T <sub>amb</sub>	Operating free air temperature range	Commercial range	0 to +70	°C
		Industrial range	-40 to +85	°C
T <sub>stg</sub>	Storage temperature range		-65 to +150	°C

**RECOMMENDED OPERATING CONDITIONS**

SYMBOL	PARAMETER	LIMITS			UNIT
		MIN	NOM	MAX	
V <sub>CC</sub>	Supply voltage	4.5	5.0	5.5	V
V <sub>IH</sub>	High-level input voltage	2.0			V
V <sub>IL</sub>	Low-level input voltage			0.8	V
I <sub>Ik</sub>	Input clamp current			-18	mA
I <sub>OH</sub>	High-level output current			-1	mA
I <sub>OL</sub>	Low-level output current			20	mA
T <sub>amb</sub>	Operating free air temperature range	Commercial range	0	+70	°C
		Industrial range	-40	+85	°C

**DC ELECTRICAL CHARACTERISTICS**

(Over recommended operating free-air temperature range unless otherwise noted.)

SYMBOL	PARAMETER	TEST CONDITIONS <sup>1</sup>	LIMITS			UNIT	
			MIN	TYP <sup>2</sup>	MAX		
V <sub>OH</sub>	High-level output voltage	V <sub>CC</sub> = MIN, V <sub>IL</sub> = MAX	±10%V <sub>CC</sub>	2.5		V	
		V <sub>IH</sub> = MIN, I <sub>OH</sub> = MAX	±5%V <sub>CC</sub>	2.7	3.4	V	
V <sub>OL</sub>	Low-level output voltage	V <sub>CC</sub> = MIN, V <sub>IL</sub> = MAX	±10%V <sub>CC</sub>		0.35	0.50	V
		V <sub>IH</sub> = MIN, I <sub>OL</sub> = MAX	±5%V <sub>CC</sub>		0.35	0.50	V
V <sub>IK</sub>	Input clamp voltage	V <sub>CC</sub> = MIN, I <sub>I</sub> = I <sub>IK</sub>		-0.73	-1.2	V	
I <sub>I</sub>	Input current at maximum input voltage	V <sub>CC</sub> = MAX, V <sub>I</sub> = 7.0V			100	μA	
I <sub>IH</sub>	High-level input current	V <sub>CC</sub> = MAX, V <sub>I</sub> = 2.7V			20	μA	
I <sub>IL</sub>	Low-level input current	V <sub>CC</sub> = MAX, V <sub>I</sub> = 0.5V			-0.6	mA	
I <sub>OS</sub>	Short-circuit output current <sup>3</sup>	V <sub>CC</sub> = MAX		-60	-150	mA	
I <sub>CC</sub>	Supply current (total)	I <sub>CCH</sub> V <sub>CC</sub> = MAX		1.0	2.0	mA	
		I <sub>CCL</sub> V <sub>CC</sub> = MAX		2.5	4.0	mA	

**NOTES:**

- For conditions shown as MIN or MAX, use the appropriate value specified under recommended operating conditions for the applicable type.
- All typical values are at V<sub>CC</sub> = 5V, T<sub>amb</sub> = 25°C.
- Not more than one output should be shorted at a time. For testing I<sub>OS</sub>, the use of high-speed test apparatus and/or sample-and-hold techniques are preferable in order to minimize internal heating and more accurately reflect operational values. Otherwise, prolonged shorting of a high output may raise the chip temperature well above normal and thereby cause invalid readings in other parameter tests. In any sequence of parameter tests, I<sub>OS</sub> tests should be performed last.

# 13-input NAND Gate

# FAST 74F133

## AC ELECTRICAL CHARACTERISTICS

SYMBOL	PARAMETER	TEST CONDITION	LIMITS						UNIT	
			$T_{amb} = +25^{\circ}\text{C}$			$T_{amb} = 0^{\circ}\text{C to } +70^{\circ}\text{C}$		$T_{amb} = -40^{\circ}\text{C to } +85^{\circ}\text{C}$		
			$V_{CC} = +5.0\text{V}$ $C_L = 50\text{pF}$ $R_L = 500\Omega$			$V_{CC} = +5.0\text{V} \pm 10\%$ $C_L = 50\text{pF}$ $R_L = 500\Omega$		$V_{CC} = +5.0\text{V} \pm 10\%$ $C_L = 50\text{pF}$ $R_L = 500\Omega$		
			MIN	TYP	MAX	MIN	MAX	MIN		MAX
$t_{PLH}$ $t_{PHL}$	Propagation delay Dn to $\bar{Q}$ n	Waveform 1	2.0 2.5	4.0 4.5	7.0 7.5	1.5 2.0	7.5 8.0	1.5 2.0	7.5 8.0	ns

## AC WAVEFORMS

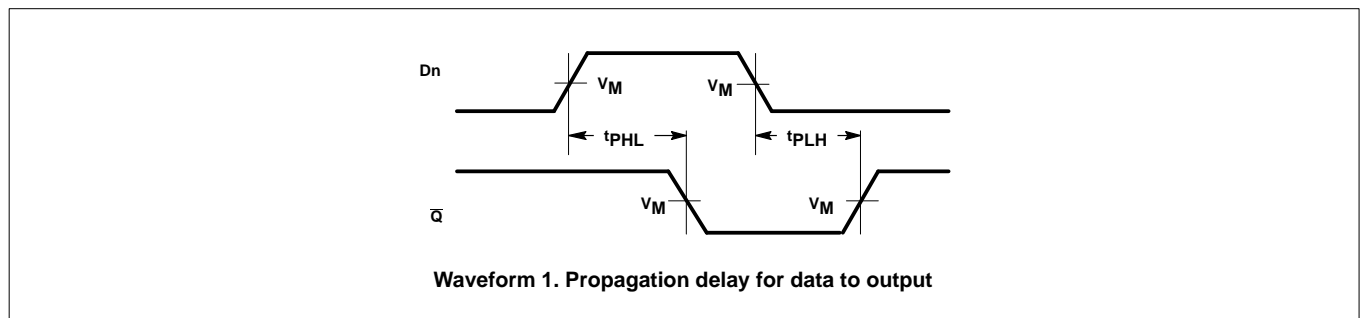

### Note to AC Waveforms

1. For all waveforms,  $V_M = 1.5\text{V}$ .

## TEST CIRCUIT AND WAVEFORMS

