

**DUAL HIGH SPEED, MEDIUM POWER
NPN SWITCHING TRANSISTOR IN A
HERMETICALLY SEALED
CERAMIC SURFACE MOUNT PACKAGE
FOR HIGH RELIABILITY APPLICATIONS**

MECHANICAL DATA
Dimensions in mm (inches)

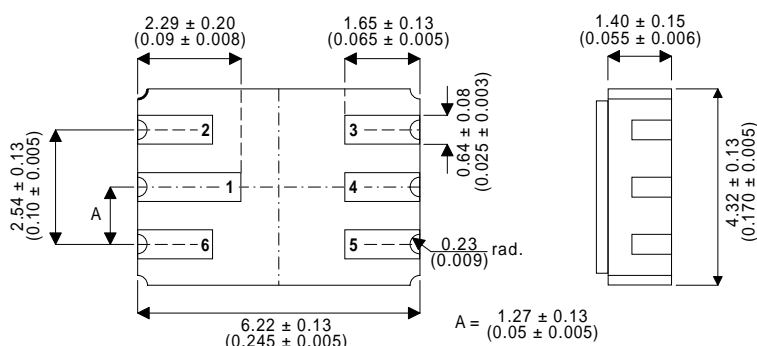

FEATURES

- DUAL SILICON PLANAR EPITAXIAL NPN TRANSISTORS
- HERMETIC CERAMIC SURFACE MOUNT PACKAGE
- CECC SCREENING OPTIONS
- SPACE QUALITY LEVELS OPTIONS
- HIGH SPEED SATURATED SWITCHING

LCC2 PACKAGE
Underside View

- | | |
|---------------------|---------------------|
| PAD 1 – Collector 1 | PAD 4 – Collector 2 |
| PAD 2 – Base 1 | PAD 5 – Emitter 2 |
| PAD 3 – Base 2 | PAD 6 – Emitter 1 |

APPLICATIONS:

Hermetically sealed dual surface mount version of the popular 2N2222A for high reliability / space applications requiring small size and low weight devices.

ABSOLUTE MAXIMUM RATINGS PER SIDE ($T_C = 25^\circ\text{C}$ unless otherwise stated)

PER SIDE		
V_{CBO}	Collector – Base Voltage	75V
V_{CEO}	Collector – Emitter Voltage ($I_B = 0$)	40V
V_{EBO}	Emitter – Base Voltage ($I_B = 0$)	6V
I_C	Collector Current	600mA
P_D	Total Device Dissipation	350mW
P_D	Derate above 50°C	2.0mW / $^\circ\text{C}$
TOTAL DEVICE		
$R_{\theta JA}$	Thermal Resistance Junction to Ambient	130 $^\circ\text{C}/\text{W}$
$R_{\theta JC}$	Thermal Resistance Junction to Case	60 $^\circ\text{C}/\text{W}$
T_{STG}, T_j	Storage Temperature, Operating Temp Range	-55 to 200 $^\circ\text{C}$

ELECTRICAL CHARACTERISTICS PER SIDE ($T_C = 25^\circ\text{C}$ unless otherwise stated)

Parameter	Test Conditions	Min.	Typ.	Max.	Unit
$V_{CEO(sus)}$ * Collector – Emitter Sustaining Voltage	$I_C = 10\text{mA}$	40			V
$V_{(BR)CBO}$ * Collector – Base Breakdown Voltage	$I_C = 10\mu\text{A}$	75			V
$V_{(BR)EBO}$ * Emitter – Base Breakdown Voltage	$I_E = 10\mu\text{A}$ $I_C = 0$	6			V
I_{CEX} * Collector Cut-off Current ($I_C = 0$)	$I_B = 0$ $V_{CE} = 60\text{V}$			10	nA
I_{CBO} * Collector – Base Cut-off Current	$I_E = 0$ $V_{CB} = 60\text{V}$			10	nA
	$T_C = 125^\circ\text{C}$			10	μA
I_{EBO} * Emitter Cut-off Current ($I_C = 0$)	$I_C = 0$ $V_{EB} = 3\text{V (off)}$			10	nA
I_{BL} * Base Current	$V_{CE} = 60\text{V}$ $V_{EB} = 3\text{V (off)}$			20	nA
$V_{CE(sat)}$ * Collector – Emitter Saturation Voltage	$I_C = 150\text{mA}$ $I_B = 15\text{mA}$			0.3	V
	$I_C = 500\text{mA}$ $I_B = 50\text{mA}$			1	
$V_{BE(sat)}$ * Base – Emitter Saturation Voltage	$I_C = 150\text{mA}$ $I_B = 15\text{mA}$	0.6		1.2	V
	$I_C = 500\text{mA}$ $I_C = 50\text{mA}$			2	
h_{FE} * DC Current Gain	$T_A = -55^\circ\text{C}$	$I_C = 0.1\text{mA}$ $V_{CE} = 10\text{V}$	35		—
		$I_C = 1\text{mA}$ $V_{CE} = 10\text{V}$	50		
		$I_C = 10\text{mA}$ $V_{CE} = 10\text{V}$	75		
		$I_C = 10\text{mA}$ $V_{CE} = 10\text{V}$	35		
		$I_C = 150\text{mA}$ $V_{CE} = 10\text{V}$	100	300	
		$I_C = 150\text{mA}$ $V_{CE} = 1\text{V}$	50		
		$I_C = 500\text{mA}$ $V_{CE} = 10\text{V}$	40		

* Pulse test $t_p = 300\mu\text{s}$, $\delta \leq 2\%$

DYNAMIC CHARACTERISTICS PER SIDE ($T_C = 25^\circ\text{C}$ unless otherwise stated)

Parameter	Test Conditions	Min.	Typ.	Max.	Unit
f_T Transition Frequency	$I_C = 20\text{mA}$ $V_{CE} = 20\text{V}$ $f = 100\text{MHz}$	300			MHz
C_{ob} Output Capacitance	$V_{CB} = 10\text{V}$ $I_E = 0$ $f = 1.0\text{MHz}$			8	pF
C_{ib} Input Capacitance	$V_{BE} = 0.5\text{V}$ $I_C = 0$ $f = 1.0\text{MHz}$			30	pF
h_{fe} Small Signal Current Gain	$I_C = 1\text{mA}$ $V_{CE} = 10\text{V}$ $f = 1\text{kHz}$	50		300	
	$I_C = 10\text{mA}$ $V_{CE} = 10\text{V}$ $f = 1\text{kHz}$	75		375	

SWITCHING CHARACTERISTICS PER SIDE (RESISTIVE LOAD)

($T_C = 25^\circ\text{C}$ unless otherwise stated)

Parameter	Test Conditions	Min.	Typ.	Max.	Unit
t_d Delay Time	$V_{CC} = 30\text{V}$ $V_{BE} = 0.5\text{V (off)}$			10	ns
t_r Rise Time		$I_{C1} = 150\text{mA}$ $I_{B1} = 15\text{mA}$			25
t_s Storage Time	$V_{CC} = 30\text{V}$ $I_C = 150\text{mA}$			225	ns
t_f Fall Time	$I_{B1} = I_{B2} = 15\text{mA}$			60	ns

f_T is defined as the frequency at which h_{FE} extrapolates to unity.