

**DESCRIPTION**

The “FemtoFarad” product family is specifically for ESD bidirectional protection of vulnerable electronic components, especially at IO ports. Continued shrinking of on-chip component geometries of sub-micron sizes have reduced levels of ESD at which upset and failure occurs to the extent that protection is mandatory for reliability of power and data line interfaces. The sub-picofarad capacitance of this series provides excellent performance up through six GHz with minimal attenuation without linear or harmonic distortion well into the GHz range. In the off-state, this FemtoFarad, polymeric based technology is virtually invisible to circuit performance. Its proven structure is thick film on a rugged ceramic base that is ideal for automated assembly. Subsequent paragraphs and charts describe the outstanding performance and reliability of FemtoFarad components and many other features that make them the designer’s choice for ESD protection.

**IMPORTANT:** For the most current data, consult MICROSEMI’s website: <http://www.microsemi.com>

**KEY FEATURES**

- Exceeds surge per IEC 61000-4-2
- Small 0603 footprint
- Linear performance at MHz levels
- Ultra-low capacitance
- Ultra-low-standby current
- Fast response time
- Bidirectional
- Lead-free plated terminals

**APPLICATIONS/BENEFITS**

- High speed data line protection
- Low signal distortion/attenuation
- ESD protection for mobile/cell phones
- Protects sensitive high frequency components

**Part Ratings and Characteristics**

Performance Characteristics	Min	Typ	Max	Units
Continuous dc operating voltage	-	-	24	V
Clamping voltage <sup>3</sup>	-	35	60	V
Trigger voltage <sup>4</sup>	-	125	-	V
ESD Threat voltage capability <sup>5</sup>	-	8	15	kV
Capacitance (@ 1 MHz)	-	0.15	0.25	pF
Standby current (@ 12 V)	0.01	<0.1	-	nA
Peak current <sup>3,5</sup>	-	30	45	A
Operating temperature	-56	+25	+85	°C
ESD pulse withstand <sup>3</sup>	20	>500 <sup>2</sup>	-	# pulses

**Notes:**

1. Continuous operation with 12 volts or more under extreme temperature and humidity may cause increasing leakage current and/or shifting device resistance. However, even under severe environmental test, characteristics of the device did not change up to 6 V dc operation.
2. Some shifting in characteristics may occur when tested over several hundred ESD pulses at very rapid rate of 1 pulse per second or faster.
3. Per IEC 61000-4-2, 30 A @ 8 kV, level 4, clamp measurement made 30 ns after initiation of pulse, all tests in contact discharge mode.
4. Trigger measurement made using Transmission Line Pulse (TLP) method.
5. FemtoFarad devices are capable of withstanding up to a 15 kV, 45 A ESD pulse. Device ratings are given at 8 kV per Note 1, unless otherwise specified.

**Environmental Specifications:**

- Moisture Resistance, steady state: MIL-STD-883, method 1004.7, 85% RH, 85°C, 240 hrs.
- Thermal shock: MIL-STD-202, Method 107G, -65°C to 125°C, 30 min. cycle, 10 cycles
- Vibration: MIL-STD-202F, Method 201A, (10 to 55 to 10 Hz, 1 min. cycle, 2 hrs each in X-Y-Z)
- Chemical resistance: ASTM D-543, 4 hrs @ 40°C, 3 solutions (H<sub>2</sub>O, detergent solution, defluxer)
- Operating temperature characteristics, measurement at +25°C, +85°C and -56°C
- Full load voltage: 14.4 V dc, 1000 hrs, 25°C
- Solder leach resistance and terminal adhesion: Per EIA-576
- Solderability: MIL-STD-202, Method 208 (95% coverage)

**Definition of Terms:**

**Clamp Voltage** – The voltage at which the TVSF0603 device stabilizes during the transition from high to low impedance. This is the voltage experienced by the circuit, after stabilizing, for the duration of the ESD transient.

**Trigger Voltage** – The voltage at which the TVSF0603 device begins to conduct. When the ESD threat voltage reaches this level, the TVSF0603 device begins the transition from high impedance to low impedance, shunting the ESD energy to ground.

**Threat Voltage** – The voltage that the test equipment is set to operate (i.e., the voltage across the discharge capacitor).

**Peak Current** – The maximum instantaneous current level that a device will receive. IEC-61000-4-2 states that the peak current should be 30 A at 8 kV ESD and 45 A at 15 kV ESD.

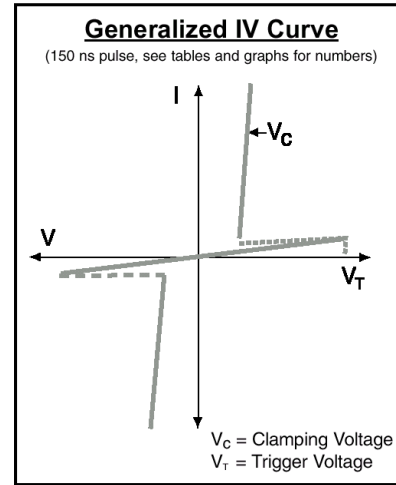

**Product Dimension**

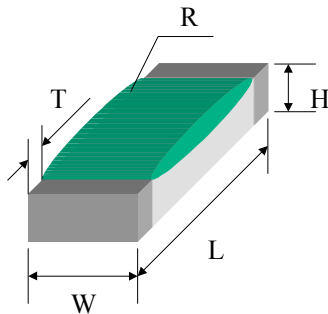

Recommended Solder Pad Outline (per IPC-SM-782)

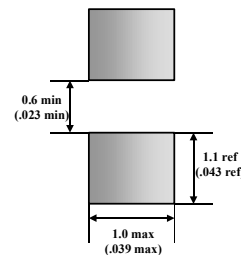

EIA SIZE	L	W	H	T	R
TVSF0603	1.60 ± 0.10 (.063 ± .004)	0.80 ± 0.10 (.031 ± .004)	0.50 ± 0.10 (.020 ± .004)	0.30 ± 0.20 (.012 ± .008)	0.70 ± .10 (.028 ± .004)

**Tape-and-Reel Specification**

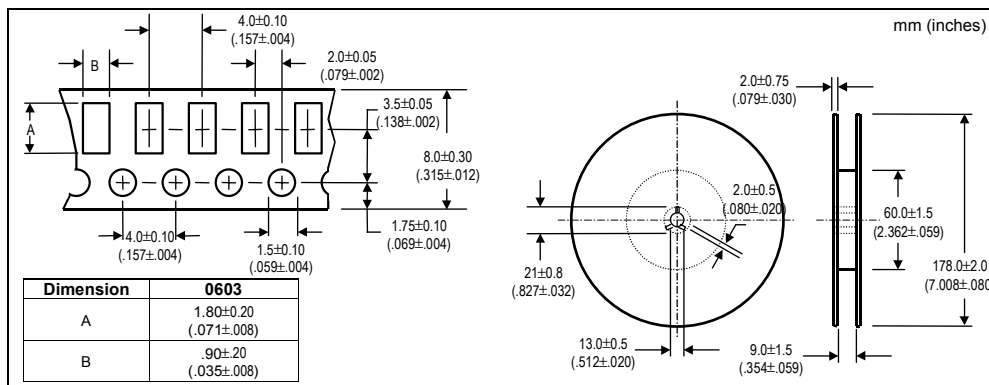

**Part Numbering**

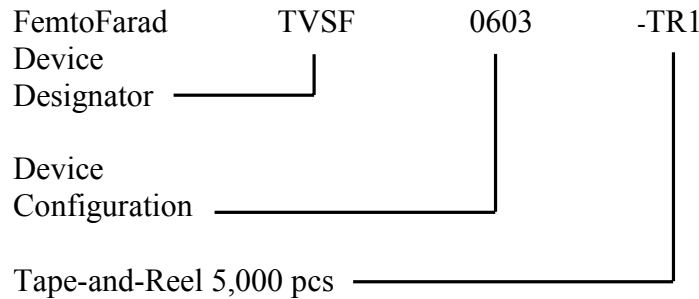

**Part Numbering**

TVSF devices are not individually marked, but labeled on the tape-and-reel unit. Components are symmetrically bi-directional, hence no polarity marking is required.

**Pick-and- Place Assembly**

TVSF devices have a slightly rounded top that is inherent in their fabrication. This slight radius does not hinder standard pick-and-place assembly methods.

**Test Methods**

Multiple test methods are often required for surge characterization and withstand verification. Results may vary according to test method since secondary effects of the Electrical and Magnetic (E and H) fields on instrumentation and non-shielded circuits may produce undesired results. This is particularly observed below 3 kV where rise times in the 100 ps range have been reported producing electromagnetic conditions equivalent to 30 kV/ns.

**ESD Open Air / Contact Discharge**

This fast rise pulse, characterized in IEC 61000-4-2, can produce peak currents up to 45A with voltage levels of 15 kV. Contact discharge is the recommended method of test because of its repeatability; however, real world ESD events are open-air human body discharges. Air discharges introduce pre-corona discharge with E and H fields that allow energy to leak through narrow vents and radiate from isolated circuit and enclosure segments. A TVSF device may be very capable of providing protection from ESD, but its function can be nullified by poor board layout and inadequate shielding. ESD surges on a conductor have been observed to electromagnetically bypass suppressors causing circuit upset or failure. Shielding may be required for supplementing suppressor protection devices.

**Transmission Line Pulse (TLP)**

The Transmission Line Pulse tester implements a controlled impedance cable to deliver a square-wave current pulse. The advantage of this technique is that the constant current of the square wave allows the behavior of the protection structure to be more accurately studied.

The actual implementation of this technique produces a waveform that has a slightly slower rise time than the ESD pulse but can be correlated to deliver approximately the same surge current and energy. This controlled impedance pulse provides a more accurate depiction of the trigger voltage of the device because of the reduced voltage overshoot caused by a fast-rising transient and the reactive components of the test fixture.

**Selected Application Data**

*ESD Transient Suppression with TVSF*

Figure 1 Depicts typical TVSF device response to an 8 kV contact ESD pulse. Triggered polymer in TVSF conducts excess energy to ground and prevents system damage from ESD transient threats.

The top scope trace is current, and the bottom scope trace is voltage.

**Figure 1. Typical Device Characteristics**

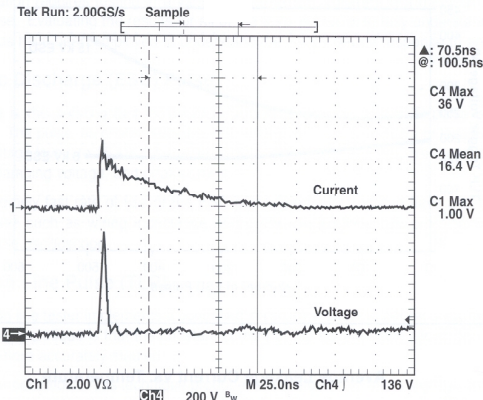

**TVSF Signal Attenuation**

The TVSF0603 ESD over voltage protection devices have an ultra-low capacitance of <math><0.25\text{ pF}</math>. When typically installed from the signal line to ground, it has a negligible effect on the signal.

Figure 2 shows the test results when conducted with a precision network analyzer on a 50  $\Omega$  circuit up to 6 GHz. Only a 0.2 dB maximum

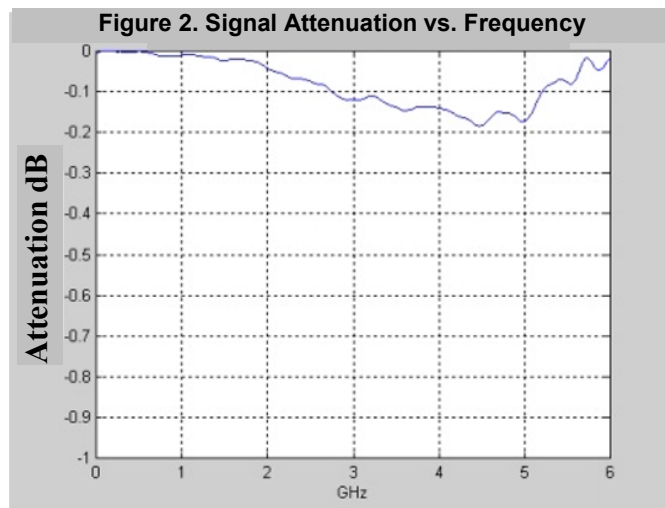

**Typical Standby Current (Leakage) of TVSF**

In Figure 3, the leakage current of TVSF Polymer is typical very low, well under 1 nA, even above 12 V dc operating voltage. Increase in leakage current can be expected at higher operating voltage and elevated temperatures.

**Figure 3. Typical Standby Current vs. Temperature**

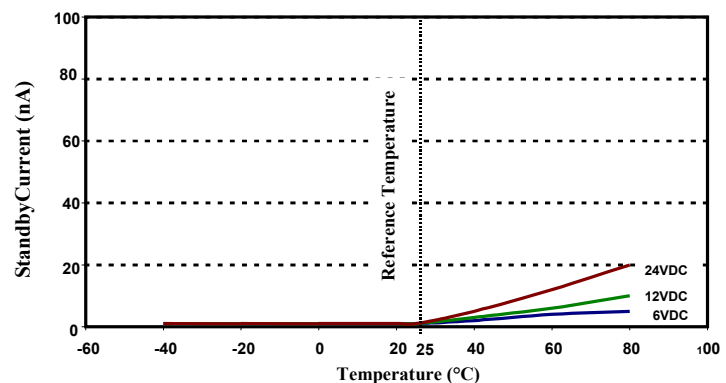

**Consistent Clamp Voltage through Many ESD Pulses**

As *Figure 4* shows, the TVSF Polymer device is reliable and stable over a duration of hundreds of pulses. The TVSF device has been tested with fast rate ESD pulses at 8kV contact discharge. Clamping voltage relatively consistent through 500 pulses. This is far more than most equipment would see in a lifetime.

Figure 4. ESD Clamping Voltage vs. Number of 8 kV ESD Pulse

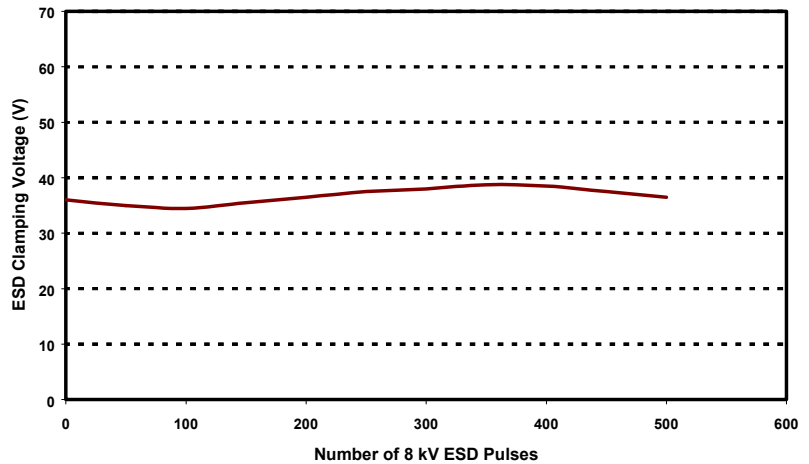

**Trigger Voltage Remains Consistent through Many ESD Pulses**

As the number of ESD pulses increase, the trigger voltage stays within specification with minimal change.

A very high rate of ESD pulsing might affect trigger voltage after hundreds of cycles, (e.g., 1 pulse per second). TVSF is designed for random events.

Figure 5. Typical Trigger Voltage vs. Number of ESD Pulses

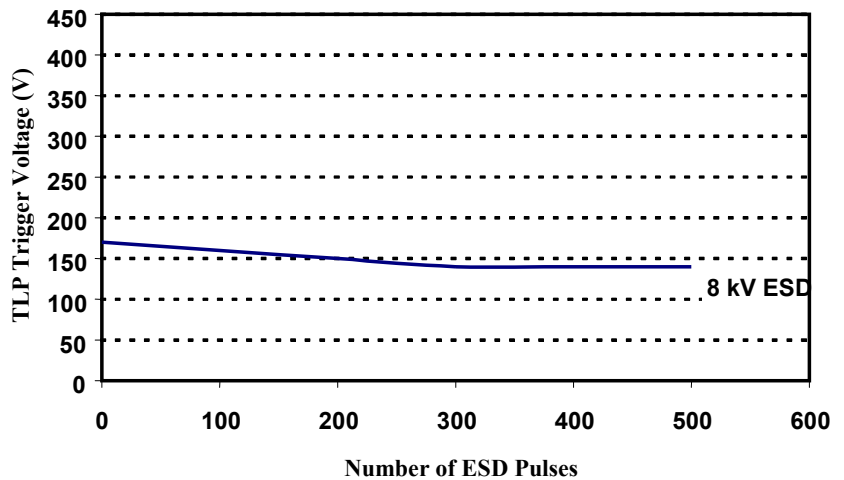

**Device Applications**

TVSF devices protect signal line circuits from ESD by placing them in a shunt-connected manner from line to ground as illustrated below. These devices are not applicable on lines where lightning or load-switching transients are present. TVSF devices are ideal for use in computers and computer-related equipment, such as modems, keyboards, and printers. They also find applications in portable electronic equipment such as mobile telephones, test equipment, and card scanners.

**Typical Applications**

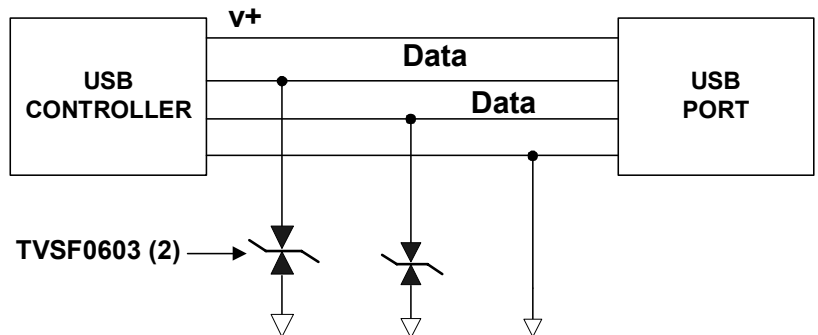
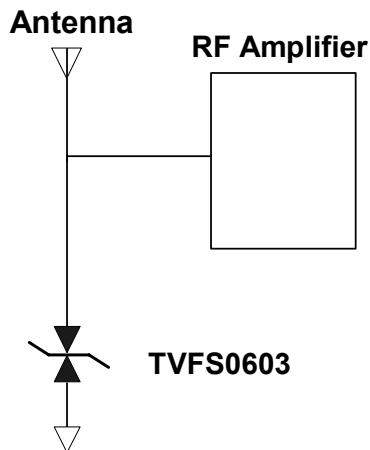
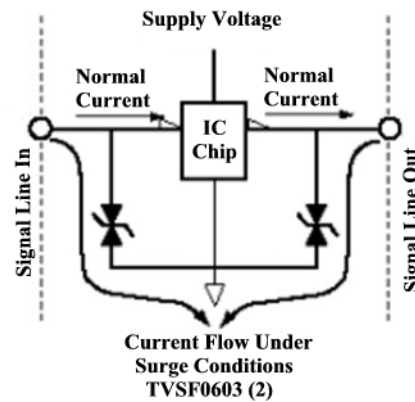
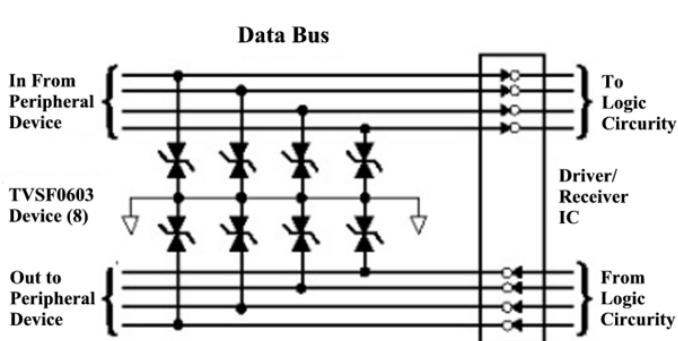

**Note:** Although diode symbols are shown in opposite directions to represent the polymer ESD suppressor, it is not a semiconductor diode. It is instead a polymer based thick film material on a ceramic substrate creating a bi-directional response in a reliable surface mount package.



TRANSIENT PROTECTION PRODUCTS

TVSF0603

“FemtoFarad” Polymer ESD Suppressor

www.Microsemi.com

NOTES