

TOSHIBA PHOTOCOUPLER PHOTO RELAY

TLP227G(N), TLP227G-2(N)

CORDLESS TELEPHONE

PBX

MODEM

The TOSHIBA TLP227G series consist of a gallium arsenide infrared emitting diode optically coupled to a photo-MOS FET in a plastic DIP package.

The TLP227G series are a bi-directional switch, which can replace mechanical relays in many applications.

FEATURES

- TLP227G : 4 pin DIP (DIP4), 1 Channel Type (1 Form A)
- TLP227G-2 : 8 pin DIP (DIP8), 2 Channel Type (2 Form A)
- Peak Off-State Voltage : 350 V (MIN.)
- Trigger LED Current : 3 mA (MAX.)
- On-State Current : 120 mA (MAX.)
- On-State Resistance : 25 Ω (MAX.)
- Isolation Voltage : 2500 Vrms (MIN.)

PIN CONFIGURATION (TOP VIEW)

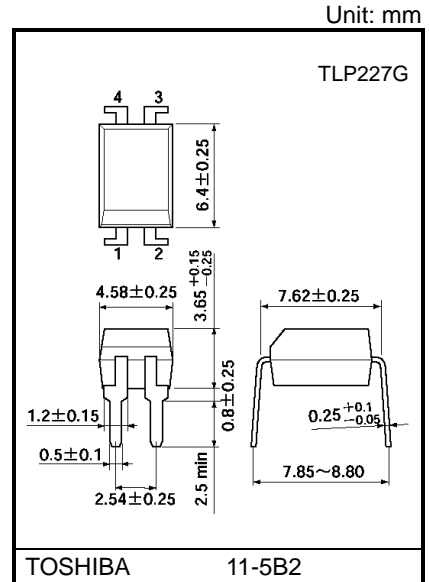
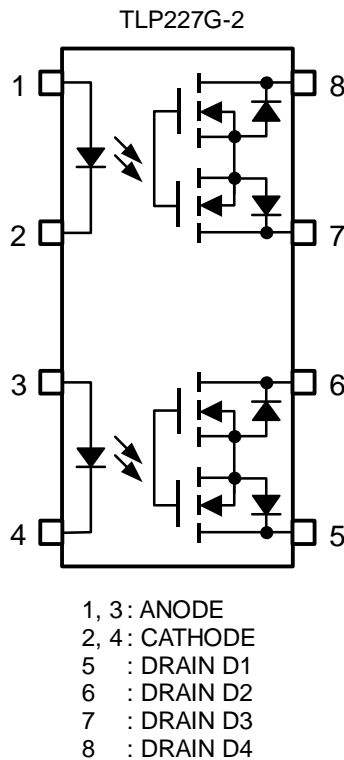
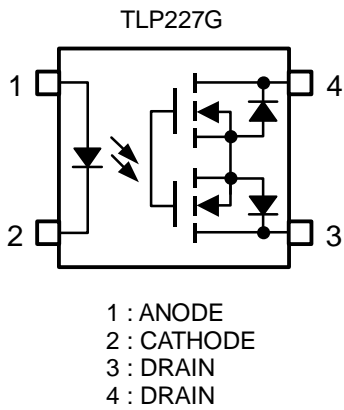

Weight: 0.26 g

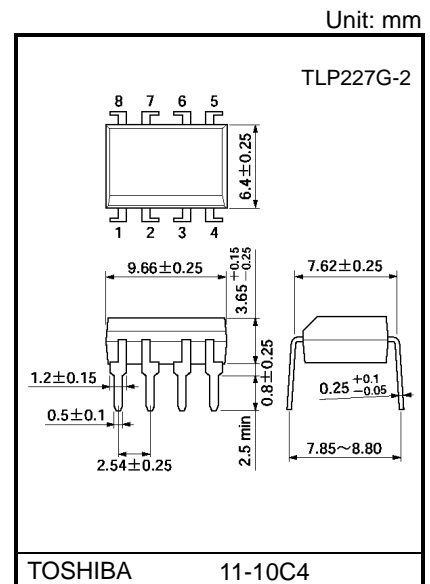
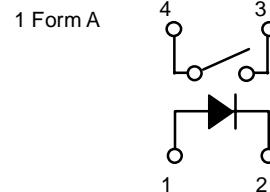

Weight: 0.54 g

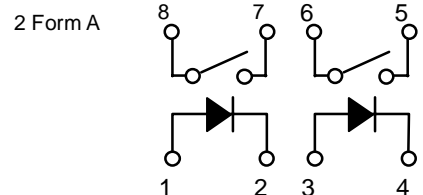

INTERNAL CIRCUIT

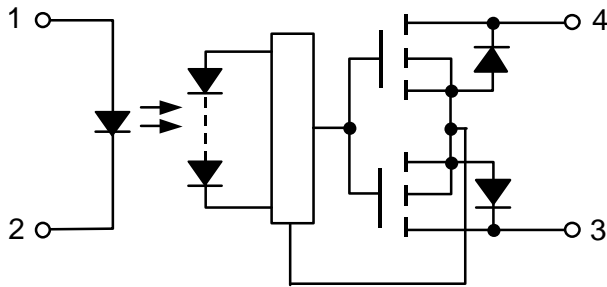

MAXIMUM RATINGS (Ta = 25°C)

CHARACTERISTIC		SYMBOL	RATING	UNIT		
LED	Forward Current	I_F	50	mA		
	Forward Current Derating (Ta ≥ 25°C)	$\Delta I_F/^\circ\text{C}$	-0.5	mA/°C		
	Peak Forward Current (100μs pulse, 100 pps)	I_{FP}	1	A		
	Reverse Voltage	V_R	5	V		
	Junction Temperature	T_j	125	°C		
DETECTOR	Off-State Output Terminal Voltage	V_{OFF}	350	V		
	On-State Current	TLP227G	I_{ON}	120	mA	
		TLP227G-2				One Channel
						Both Channel (Note 1)
	On-State Current Derating (Ta ≥ 25°C)	TLP227G	$\Delta I_{ON}/^\circ\text{C}$	-1.2	mA/°C	
		TLP227G-2				One Channel
					Both Channel (Note 1)	
Junction Temperature		T_j	125	°C		
Storage Temperature Range		T_{stg}	-55~125	°C		
Operating Temperature Range		T_{opr}	-40~85	°C		
Lead Soldering Temperature (10 s)		T_{sol}	260	°C		
Isolation Voltage (AC, 1 minute, R.H. ≤ 60%)		BV_S	2500	Vrms		

(Note 1) :Two channels operating simultaneously.

(Note 2):Device considered a two-terminal device : LED side pins shorted together, and DETECTOR side pins shorted together.

RECOMMENDED OPERATING CONDITIONS

CHARACTERISTIC	SYMBOL	MIN.	TYP.	MAX.	UNIT
Supply Voltage	V_{DD}	—	—	280	V
Forward Current	I_F	5	7.5	25	mA
On-State Current	I_{ON}	—	—	120	mA
Operating Temperature	T_{opr}	-20	—	65	°C

INDIVIDUAL ELECTRICAL CHARACTERISTICS (Ta = 25°C)

CHARACTERISTIC		SYMBOL	TEST CONDITION	MIN.	TYP.	MAX.	UNIT
LED	Forward Voltage	V_F	$I_F = 10 \text{ mA}$	1.0	1.15	1.3	V
	Reverse Current	I_R	$V_R = 5 \text{ V}$	—	—	10	μA
	Capacitance	C_T	$V = 0, f = 1 \text{ MHz}$	—	30	—	pF
DETECTOR	Off-State Current	I_{OFF}	$V_{OFF} = 350 \text{ V}$	—	—	1	μA
	Capacitance	C_{OFF}	$V = 0, f = 1 \text{ MHz}$	—	40	—	pF

COUPLED ELECTRICAL CHARACTERISTICS (Ta = 25°C)

CHARACTERISTIC	SYMBOL	TEST CONDITION	MIN.	TYP.	MAX.	UNIT
Trigger LED Current	I_{FT}	$I_{ON} = 120 \text{ mA}$	—	1	3	mA
Close LED Current	I_{FC}	$I_{OFF} = 100 \mu\text{A}$	0.1	—	—	mA
On-State Resistance	R_{ON}	$I_{ON} = 120 \text{ mA}, I_F = 5 \text{ mA}$	—	14	25	Ω

ISOLATION CHARACTERISTICS (Ta = 25°C)

CHARACTERISTIC	SYMBOL	TEST CONDITION	MIN.	TYP.	MAX.	UNIT
Capacitance Input to Output	C_S	$V_S = 0 \text{ V}, f = 1 \text{ MHz}$	—	0.8	—	pF
Isolation Resistance	R_S	$V_S = 500 \text{ V}, \text{R.H.} \leq 60\%$	5×10^{10}	10^{14}	—	Ω
Isolation Voltage	BV_S	AC, 1 minute	2500	—	—	Vrms
		AC, 1 second (in oil)	—	5000	—	—
		DC, 1 minute (in oil)	—	5000	—	Vdc

SWITCHING CHARACTERISTICS (Ta = 25°C)

CHARACTERISTIC	SYMBOL	TEST CONDITION	MIN.	TYP.	MAX.	UNIT
Turn-on Time	t_{ON}	$R_L = 200 \Omega$ $V_{DD} = 20 \text{ V}, I_F = 5 \text{ mA}$ (Note 3)	—	0.3	1	ms
Turn-off Time	t_{OFF}		—	0.1	1	

(Note 3) : SWITCHING TIME TEST CIRCUIT

