

Advance Information

Quad H-Bridge Micromotor Driver with DC/DC Boost Converter

The 17550 is a monolithic quad H-Bridge power IC ideal for portable electronic applications containing tiny bipolar stepper motors and/or brush DC-motors powered by two-to-four cell NiCd/NiMH batteries.

The 17550 operates from 2.5 V to 5.5 V, with independent control of each H-Bridge via parallel 3.0 V or 5.0 V logic-compatible I/O. The device features an on-board DC/DC boost converter that allows motor operation all the way down to 1.6 V (the boost converter supplies the gate-drive voltage for each of the four independent H-bridge output stages). Each output bridge has its own gate-drive and logic circuitry with built-in shoot-through current protection.

The 17550 has four operating modes: Forward, Reverse, Brake, and Tri-States (High Impedance). The 17550 has a low total $R_{DS(ON)}$ of 1.2 Ω max @ 25°C. In addition, it can be set into a very low current-drain standby mode.

The H-Bridge outputs can be independently PWM'ed at up to 200 kHz for speed/torque and current control. The 17550 can efficiently drive many types of micromotors owing to its low output resistance and high output slew rates.

Features

- Low Total $R_{DS(ON)}$ 0.7 Ω (Typ), 1.2 Ω (Max) @ 25°C
- Output Current 700 mA (Continuous per Output)
- Shoot-Through Current Protection Circuit
- PWM Control Input Frequency up to 200 kHz
- Built-In DC/DC Boost Converter
- Low Power Consumption Standby Mode
- Undervoltage Detection and Shutdown Circuit
- Pb-Free Packaging Designated by Suffix Code EV

17550

QUAD H-BRIDGE MICROMOTOR DRIVER WITH DC/DC BOOST CONVERTER

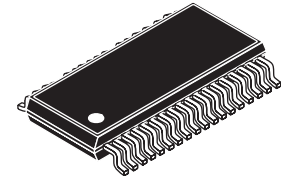

EV (Pb-FREE) SUFFIX
CASE 1522-01
36-LEAD VMFP

ORDERING INFORMATION

Device	Temperature Range (T _A)	Package
MPC17550EV/EL	-10°C to 60°C	36 VMFP

17550 Simplified Application Diagram

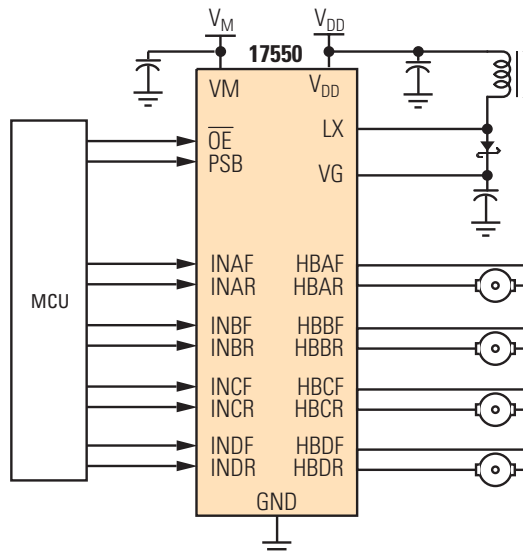

This document contains certain information on a new product. Specifications and information herein are subject to change without notice.

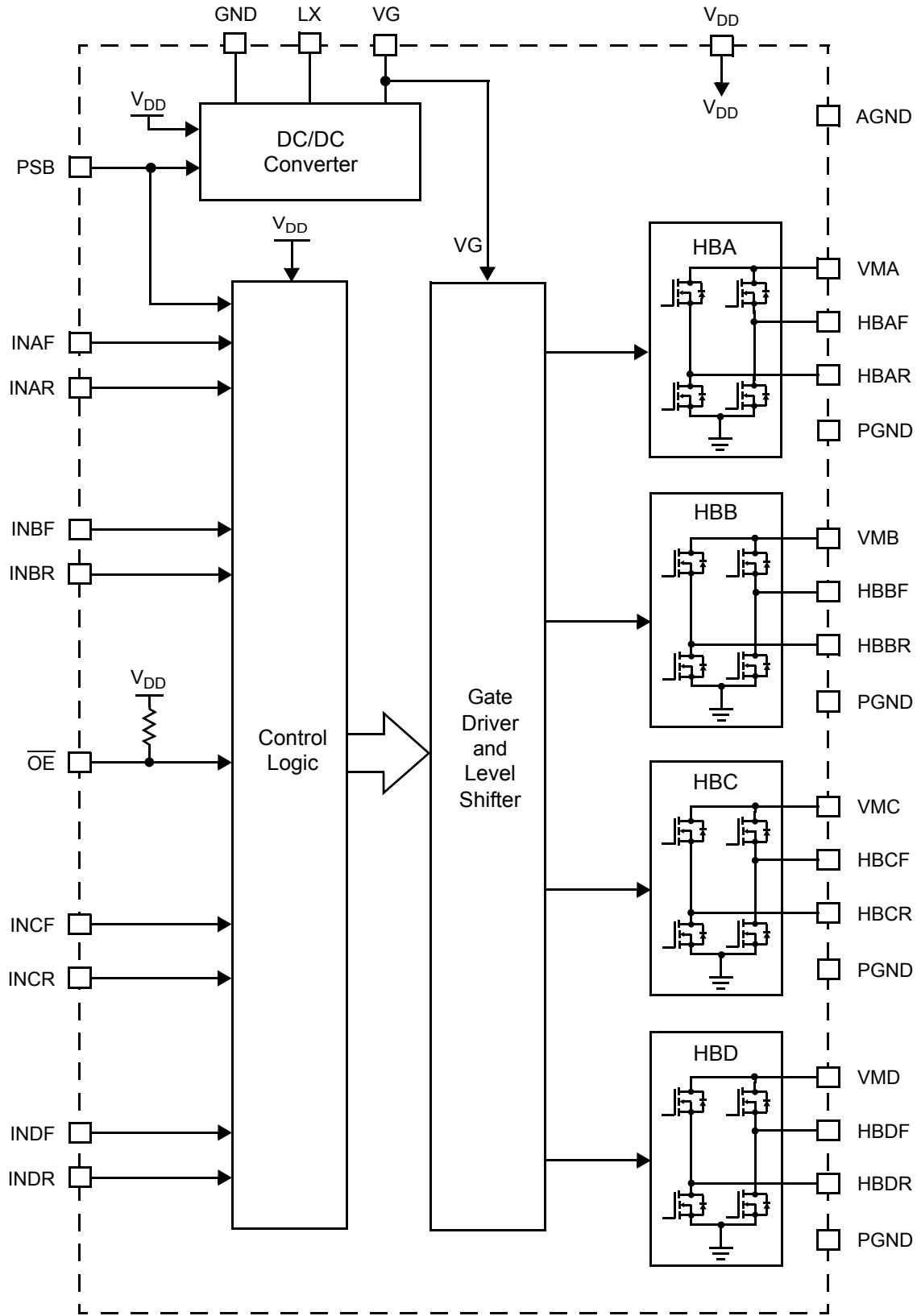
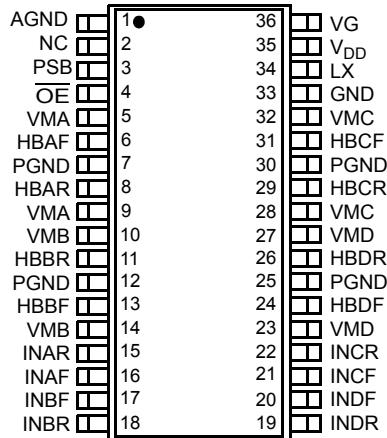

Figure 1. 17550 Simplified Internal Block Diagram



TERMINAL FUNCTION DESCRIPTION

Terminal	Terminal Name	Formal Name	Definition
1	AGND	Analog Ground	Analog and logic signal ground reference terminal.
2	NC	No Connect	No connection to this terminal.
3	PSB	Power Standby	Power standby mode control terminal.
4	\overline{OE}	Output Enable	Logic output Enable control of H-Bridges (Low = True).
5, 9	VMA	Motor Drive Power Supply A	Power supply voltage connection for Motor "A" (top of HBA).
6	HBAF	HBA Forward Output	Forward output of H-Bridge A.
8	HBAR	HBA Reverse Output	Reverse output of H-Bridge A.
10, 14	VMB	Motor Drive Power Supply B	Power supply voltage connection for Motor "B" (top of HBB).
11	HBBR	HBB Reverse Output	Reverse output of H-Bridge B.
7, 12, 25, 30	PGND	Power Ground	Power ground connection.
13	HBBF	HBB Forward Output	Forward output of H-Bridge B.
15	INAR	Input Control HBA Reverse	Control signal input for H-Bridge A reverse.
16	INAF	Input Control HBA Forward	Control signal input for H-Bridge A forward.
17	INBF	Input Control HBB Forward	Control signal input for H-Bridge B forward.
18	INBR	Input Control HBB Reverse	Control signal input for H-Bridge B reverse.
19	INDR	Input Control HBD Reverse	Control signal input for H-Bridge D reverse.
20	INDF	Input Control HBD Forward	Control signal input for H-Bridge D forward.
21	INCF	Input Control HBC Forward	Control signal input for H-Bridge C forward.
22	INCR	Input Control HBC Reverse	Control signal input for H-Bridge C reverse.
23, 27	VMD	Motor Drive Power Supply D	Power supply voltage connection for Motor "D" (top of HBD).
24	HBDF	HBD Forward Output	Forward output of H-Bridge D.
26	HBDR	HBD Reverse Output	Reverse output of H-Bridge D.
28, 32	VMC	Motor Drive Power Supply C	Power supply voltage connection for Motor "C" (top of HBC).
29	HBCR	HBC Reverse Output	Reverse Output of H-Bridge C.
31	HBCF	HCB Forward Output	Forward Output of H-Bridge C.

Freescale Semiconductor, Inc.

TERMINAL FUNCTION DESCRIPTION (continued)

Terminal	Terminal Name	Formal Name	Definition
33	GND	Ground	Control circuit ground terminal for DC/DC circuit ground.
34	LX	DC/DC Converter Switching Transistor Output	Open-drain output of the internal DC/DC converter circuit.
35	V _{DD}	Logic Supply	Control circuit power supply terminal.
36	VG	Gate-Driver Circuit Power Supply	Input terminal for the gate-drive voltage.

MAXIMUM RATINGS

All voltages are with respect to ground unless otherwise noted. Exceeding the ratings may cause a malfunction or permanent damage to the device.

Rating	Symbol	Value	Unit
Motor Supply Voltage	V_M	-0.5 to 9.0	V
Gate-Driver Circuit Power Supply Voltage	V_G	$V_{DD}-0.5$ to 14	V
Logic Supply Voltage	V_{DD}	-0.5 to 6.0	V
Signal Input Voltage (Note 1)	V_{IN}	-0.5 to $V_{DD}+0.5$	V
Driver Output Current			A
Continuous (Note 2)	I_O	0.7	
Peak (Note 3)	I_{OPK}	2.0	
ESD Voltage			V
Human Body Model (Note 4)	V_{ESD1}	± 2000	
Machine Model (Note 5)	V_{ESD2}	± 100	
Storage Temperature Range	T_{STG}	-65 to 150	$^{\circ}C$
Operating Ambient Temperature	T_A	-10 to 60	$^{\circ}C$
Operating Junction Temperature	T_J	-10 to 150	$^{\circ}C$
Thermal Resistance (Note 6)	$R_{\theta JA}$	TBD	$^{\circ}C/W$
Power Dissipation (Note 7)	P_D	1500	mW
Soldering Temperature (Note 8)	T_{SOLDER}	260	$^{\circ}C$

Notes

- V_{IN} is the voltage level applied to any input terminal.
- I_O is measured as the load current flowing through the H-bridge.
- $T_A = 25^{\circ}C$, pulse width < 10 ms at intervals > 0.2 seconds.
- ESD1 testing is performed in accordance with the Human Body Model ($C_{ZAP} = 100$ pF, $R_{ZAP} = 1500 \Omega$).
- ESD2 testing is performed in accordance with the Machine Model ($C_{ZAP} = 200$ pF, $R_{ZAP} = 0 \Omega$).
- Mounted on 37 x 50 Cu area (1.6 mm FR-4 PCB).
- Maximum at $T_A = 25^{\circ}C$.
- Soldering temperature limit is for 10 seconds maximum duration. Not designed for immersion soldering. Exceeding these limits may cause malfunction or permanent damage to the device.

STATIC ELECTRICAL CHARACTERISTICS

Characteristics noted under conditions $T_A = 25^\circ\text{C}$, $V_{DD} = 3.0\text{ V}$, $V_M = 2.5\text{ V}$, $\text{GND} = 0\text{ V}$, $f_{IN} = 176\text{ kHz}$ unless otherwise noted. Typical values noted reflect the approximate parameter means at $T_A = 25^\circ\text{C}$ under nominal conditions unless otherwise noted.

Characteristic	Symbol	Min	Typ	Max	Unit
POWER					
Motor Supply Voltage	V_M	1.6	2.5	5.5	V
Logic Supply Voltage	V_{DD}	2.5	3.0	5.5	V
Standby Power Supply Current (Note 9)					μA
Motor Supply Standby Current	$I_{V_{MSTBY}}$	–	–	1.0	
Logic Supply Standby Current	$I_{V_{DDSTBY}}$	–	–	1.0	
Logic Supply Current	$I_{V_{DD}}$	–	0.3	1.0	mA
Gate Driver Circuit Power Supply Current (Note 10)					μA
Standby (PSB = "L")	I_{DDCO}	–	–	1.0	
No Signal Operating	I_{DDCN}	–	1.0	3.0	μA
Input Signal Operating (Note 11)	I_{DDC}	–	19	25	mA
Driver Output ON Resistance (Note 12)	$R_{DS(ON)}$	–	0.7	1.2	Ω

GATE DRIVE

Gate Driver Circuit Power Supply Voltage (Note 13)	V_G	10	11.5	13	V
--	-------	----	------	----	---

CONTROL LOGIC

Logic Input Voltage (Note 14)	V_{IN}	0	–	V_{DD}	V
Logic Input (F, R, PSB, \overline{OE})					
High-Level Input Voltage	V_{IH}	$V_{DD} \times 0.7$	–	–	V
Low-Level Input Voltage	V_{IL}	–	–	$V_{DD} \times 0.3$	V
High-Level Input Current	I_{IH}	–	–	1.0	μA
Low-Level Input Current	I_{IL}	-1.0	–	–	μA

Notes

9. Applies individually to each H-Bridge.
10. Average inductor current for DC/DC converter (connected between V_{DD} and LX [L = 1.0 mH, C = 2.2 μF]).
11. Full drive (input signal to all input terminals).
12. The total H-bridge ON resistance when V_G is 11.5 V.
13. When voltage is supplied externally without built-in DC/DC.
14. V_{IN} is the voltage level applied to any input.

DYNAMIC ELECTRICAL CHARACTERISTICS

Characteristics noted under conditions $T_A = 25^\circ\text{C}$, $V_{DD} = 3.0\text{ V}$, $V_M = 2.5\text{ V}$, $\text{GND} = 0\text{ V}$, $f_{IN} = 176\text{ kHz}$ unless otherwise noted. Typical values noted reflect the approximate parameter means at $T_A = 25^\circ\text{C}$ under nominal conditions unless otherwise noted.

Characteristic	Symbol	Min	Typ	Max	Unit
----------------	--------	-----	-----	-----	------

INPUT

Pulse Input Frequency (Note 15)	f_{IN}	–	–	200	kHz
Internal Oscillator Frequency	f_{OSC}	–	100	200	kHz

OUTPUT

Gate Driver Circuit Power Supply Wake-Up Time	t_{VGON}	–	10	20	ms
Propagation Delay Time					μs
Turn-ON Time	t_{PLH}	–	0.2	1.0	
Turn-OFF Time	t_{PHL}	–	0.2	1.0	

Notes

15. f_{IN} is the signal frequency applied to an input terminal (F, R).

Timing Diagrams

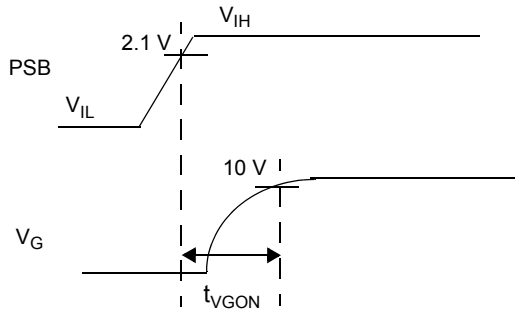

Figure 2. DC/DC Converter Output Waveform

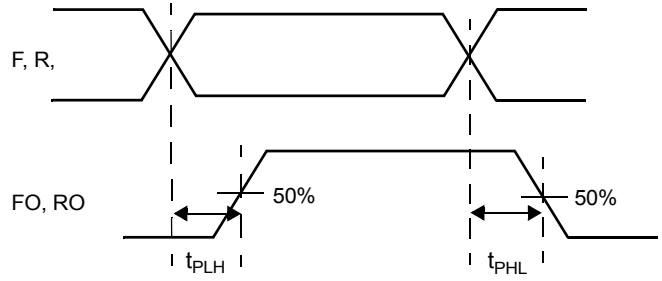

Figure 3. H-Bridge Output Waveform

Table 1. Truth Table

PSB, \overline{OE}		INA/INB/INC/IND		HBA/HBB/HBC/HBC	
PSB	\overline{OE}	IN*F	IN*R	HB*F	HB*R
H	L	L	L	L	L
H	L	L	H	L	H
H	L	H	L	H	L
H	L	H	H	Z	Z
H	H	X	X	Z	Z
L	X	X	X	Z	Z

H = High.
 L = Low.
 Z = High impedance.
 X = Don't care.
 * = A, B, C, or D.

SYSTEM/APPLICATION INFORMATION

INTRODUCTION

The 17550 is a monolithic quad H-Bridge ideal for portable electronic applications containing multiple bipolar step motors and/or brush DC motors. The device features an on-board DC/DC converter to provide gate-drive voltages, as well as level-shifting circuitry. The control logic translates the input signals to the gate-driver circuitry while providing cross-conduction suppression.

The 17550 has four operating modes: Forward, Reverse, Brake, and Tri-States (High Impedance). The MOSFETs comprising the output bridge have a total source + sink $R_{DS(ON)} \leq 1.2 \Omega$.

The 17550 can simultaneously drive four brush DC motors or two bipolar step motors. The drivers are designed to be PWM'ed at frequencies up to 200 kHz.

FUNCTIONAL TERMINAL DESCRIPTION

V_{DD}

The V_{DD} terminal carries the logic supply voltage and current into the logic sections of the IC. V_{DD} has an undervoltage threshold. If the supply voltage drops below the undervoltage threshold, the output power stage switches to a tri-state condition. When the supply voltage returns to a level that is above the threshold, the power stage automatically resumes normal operation according to the established condition of the input terminals.

INAF, INAR, INBF, INBR, INCF, INCR, INDF, INDR

These logic input terminals control each H-Bridge output; e.g., IN*F logic HIGH = HB*F HIGH; likewise, IN*R logic HIGH = HB*R HIGH. However, if both "F" and "R" inputs are taken HIGH, the associated bridge's outputs are both tri-stated (refer to [Table 1, Truth Table](#), page 8).

\overline{OE}

\overline{OE} terminal is a LOW = TRUE enable input. When \overline{OE} = HIGH, all H-Bridge outputs are tri-stated (high impedance) regardless of logic inputs states.

HBAF, HBAR, HBBF, HBBR, HBCF, HBCR, HBDF, HBDR

These terminals provide connection to the outputs of each of the internal H-Bridges (see [Figure 1, 17550 Simplified Internal Block Diagram](#), page 2).

VM

The VM terminals carry the main supply voltage and current into the power sections of the 17550. This supply then becomes controlled and/or modulated by the 17550 as it delivers the power to the loads attached between the H-Bridge output terminals. All VM terminals must be connected together on the printed circuit board.

LX

The LX terminal is the open-drain output of the internal DC/DC converter circuit. It is the junction of the external inductor and the anode of the external Schottky diode.

VG

The VG terminal is the input terminal for the gate-drive voltage. It can be supplied from the built-in DC/DC converter or from an external source.

Ground Terminals

All ground terminals must be tied together on the PCB.

APPLICATIONS

Introduction

The 17550's built-in DC/DC converter must be connected to an external inductor, rectifier, and filter capacitor. This step-up converter generates the gate-drive voltage, V_G , required by the internal gate driver circuits. Although there is some latitude in selecting the values for the external component, care must be taken that V_G does not exceed 14 V. Additionally, too low an inductance will cause large instantaneous switching currents, which may damage the device.

Important Do not use an inductance lower than 330 μH .

To attain high-efficiency operation, the rectifier should be a Schottky diode, and the filter capacitor should be of the low ESR type. Attention should be paid to proper switch mode power supply PCB layout practice. Some experimentation may be required to determine optimal external component values. The recommended starting values are $L = 1.0 \text{ mH}$, $C = 2.2 \mu\text{F}$.

The DC/DC converter includes its own internal oscillator and does not require an external clock input.

Typical Application

A typical application schematic is shown in [Figure 4](#).

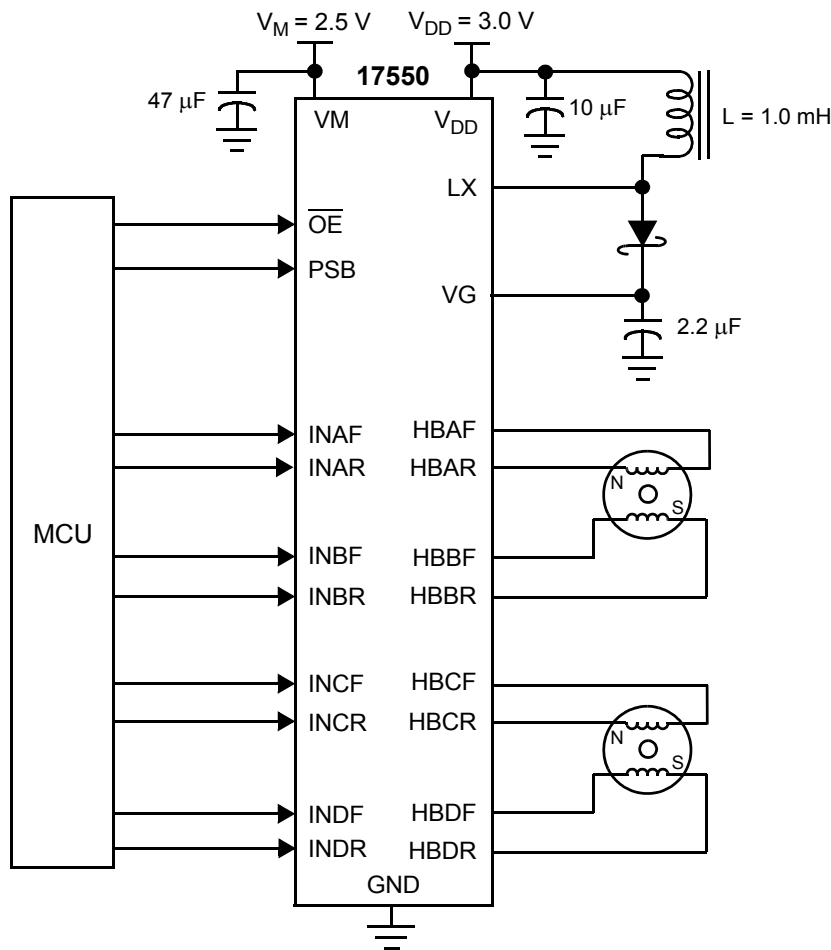

Figure 4. Typical 17550 Application

CEMF Snubbing Techniques

Care must be taken to protect the IC from potentially damaging CEMF spikes induced when commutating currents in inductive loads. Typical practice is to provide snubbing of voltage transients by placing a capacitor or zener at the motor supply voltage terminal (VM) (see [Figure 5](#)).

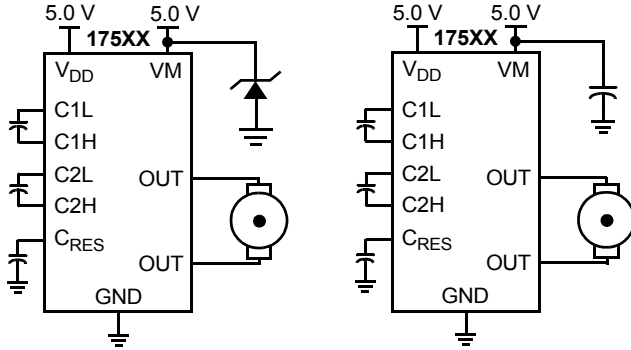

Figure 5. CEMF Snubbing Techniques

Freescale Semiconductor, Inc.

NOTES

NOTES

NOTES

Information in this document is provided solely to enable system and software implementers to use Motorola products. There are no express or implied copyright licenses granted hereunder to design or fabricate any integrated circuits or integrated circuits based on the information in this document.

Motorola reserves the right to make changes without further notice to any products herein. Motorola makes no warranty, representation or guarantee regarding the suitability of its products for any particular purpose, nor does Motorola assume any liability arising out of the application or use of any product or circuit, and specifically disclaims any and all liability, including without limitation consequential or incidental damages. "Typical" parameters which may be provided in Motorola data sheets and/or specifications can and do vary in different applications and actual performance may vary over time. All operating parameters, including "Typicals" must be validated for each customer application by customer's technical experts. Motorola does not convey any license under its patent rights nor the rights of others. Motorola products are not designed, intended, or authorized for use as components in systems intended for surgical implant into the body, or other applications intended to support or sustain life, or for any other application in which the failure of the Motorola product could create a situation where personal injury or death may occur. Should Buyer purchase or use Motorola products for any such unintended or unauthorized application, Buyer shall indemnify and hold Motorola and its officers, employees, subsidiaries, affiliates, and distributors harmless against all claims, costs, damages, and expenses, and reasonable attorney fees arising out of, directly or indirectly, any claim of personal injury or death associated with such unintended or unauthorized use, even if such claim alleges that Motorola was negligent regarding the design or manufacture of the part.

MOTOROLA and the Stylized M Logo are registered in the US Patent and Trademark Office. All other product or service names are the property of their respective owners.

© Motorola, Inc. 2004

HOW TO REACH US:

USA/EUROPE/LOCATIONS NOT LISTED:

Motorola Literature Distribution
P.O. Box 5405, Denver, Colorado 80217
1-800-521-6274 or 480-768-2130

JAPAN: Motorola Japan Ltd.; SPS, Technical Information Center
3-20-1 Minami-Azabu, Minato-ku, Tokyo 106-8573, Japan
81-3-3440-3569

ASIA/PACIFIC: Motorola Semiconductors H.K. Ltd.; Silicon Harbour Centre
2 Dai King Street, Tai Po Industrial Estate, Tai Po, N.T., Hong Kong
852-26668334

HOME PAGE: <http://motorola.com/semiconductors>



MOTOROLA

**For More Information On This Product,
Go to: www.freescale.com**

MPC17550