

Control of Lithium Ion Battery Charging and Discharging Monolithic IC MM1248

Outline

This IC was developed for use in controlling charging and discharging of lithium ion batteries (battery modules with three cells connected in series). In charging control, the voltage of the battery module as a whole is controlled in constant-voltage control. Discharge control and monitoring of overvoltage rely on monitoring of the voltages of individual cells.

Features

1. Charging control voltage $V_{BATH}=12.465V\pm 1.5\%$ ($T_a=-20^{\circ}C\sim 70^{\circ}C$)
2. Overcharge detection voltage $V_{CELL}=4.335V\pm 1.5\%$ ($T_a=-20^{\circ}C\sim 70^{\circ}C$)
3. Internal circuit for setting dead time (for overvoltage detection, discharge control)
4. Low consumption current on overdischarge $I_{BATH3}=1\mu A$ typ.
5. High-precision internal overvoltage detection startup circuit (cell voltage 4.2V or higher at end of charging)

Package

SOP-16B (MM1248XF)

Absolute Maximum Ratings (Except where noted otherwise, $T_a=25^{\circ}C$)

Item	Symbol	Ratings	Units
Storage temperature	T_{STG}	-40~+125	$^{\circ}C$
Operating temperature	T_{OPR}	-20~+70	$^{\circ}C$
Input voltage	V_{IN} max.	18	V
Charge voltage	V_{BAT} max.	15	V
Power supply voltage	V_{CC} max.	15	V
Voltage applied to OV2 pin	V_{O2} max.	10	V
Allowable loss	P_d	350	mW

Electrical Characteristics (Except where noted otherwise, Ta=25°C, VIN=15 V, CON=VIN)

Item	Symbol	Measurement conditions	Min.	Typ.	Max.	Units
Consumption current 1 (pin VIN)	VIN	VIN=15V, CON=0V		250	350	μA
Consumption current (pin VCC) 1	ICC1	VCELL=4.4V		2.1	2.6	mA
Consumption current (pin VCC) 2	ICC2	VCELL=4.2V, CON=0V		1.5	2.0	mA
Consumption current (pin VCC) 3	ICC3	VCELL=4.2V, CON=VIN		1.0	1.3	mA
Consumption current (pin VCC) 4	ICC4	VCELL=4.0V		50	100	μA
Consumption current (pin VCC) 5	ICC5	VCELL=2.4V			0.1	μA
Consumption current (pin BATH) 1	IBATH1	VCELL=4.4V		5.0	10.0	μA
Consumption current (pin BATH) 2	IBATH2	VCELL=4.0V		2.5	5.0	μA
Consumption current (pin BATH) 3	IBATH3	VCELL=2.4V		1.0	2.0	μA
Charging control voltage	VBATH	Ta=-20~70°C	12.270	12.465	12.670	V
Overcharge detection voltage	VCELLU	Ta=-20~70°C	4.270	4.335	4.400	V
Overcharge reset voltage	VCELL0		VCELLU -60mV	VCELLU -45mV	VCELLU -30mV	V
Sensing voltage margin 1	ΔVUO1	VBATH/3-VCELLU	100			mV
Sensing voltage margin 2	ΔVUO2	VBATH-VCELLU×3	300			mV
Overvoltage sensing operation voltage	VALM		4.05	4.20	4.35	V
Overvoltage sensing hysteresis voltage	ΔVALM		50	90	130	mV
Overdischarge detection voltage	VCELLS		2.31	2.40	2.49	V
Discharge resume voltage	VCELLD		2.49	2.65	2.81	V
Overdischarge sensing hysteresis voltage	ΔVCS D	VCELLD-VCELLS	175	250	325	mV
Pin 11 input current 1	I11	VCELL=4.0V	100	200	300	nA
Pin 11 input current 2	I11A	VCELL=4.4V	0.7	1.0	1.3	μA
Pin 13 input current 1	I13	VCELL=4.0V	100	200	300	nA
Pin 13 input current 2	I13A	VCELL=4.4V	0.7	1.0	1.3	μA
Pin 14 input current	I14	VCELL=4.0V	7.7	10.0	14.3	μA
CON pin threshold voltage	VTHCON		VIN-1.8		VIN-0.4	V
CON pin input current	INCON	VIN-CON=1.8V			100	μA
CON pin leakage current	ILCON	VIN-CON=0.4V			1.0	μA
CHG pin pull-up resistance	RCHG	Resistance across pins VIN and CHG	14	20	26	kΩ
CHG pin sync current	ISCGH	VBATT<12V	100			μA
CHG pin output voltage L	VTHCHL	VIN-CHG, ICGH=20μA	6.2			V
CHG pin output voltage H	VTHCHH	VIN-CHG, ICGH=20μA			0.4	V
DCHG pin source current	IsoDCH		20			μA
DCHG pin sync current	ISiDCH		20			μA
DCHG pin output voltage L	VTHDcL	BATH-DCHG, IS=20μA			1.0	V
DCHG pin output voltage H	VTHDcH	DCHG-GND, IS=-20μA			0.8	V
OV2 pin sync current	IsoOv2		100			μA
OV1 pin source current	IsoOv1		100			μA
OV1 pin pulldown resistance	ROv1		35	50	65	kΩ
CCC pin charge current	ICCC	VCELL=4.4V, CCC=3.0V	150	220	290	nA
CCC pin threshold voltage	VTHCCC	CCC=0V→5V	4.10	4.30	4.50	V
CCC initialization delay time	TINT	CCC=0.068μF		10		mS
CDC pin charge current	ICDC	VCELL=2.8V, CCC=3.0V	260	380	500	nA
CDC pin threshold voltage	VTHCDC	CCC=0V→5V	4.20	4.40	4.60	V
Overvoltage sensing dead time	TDCCC	CCC=0.068μF	0.5	1.0	1.5	S
Overdischarge sensing dead time	TDCDC1	CDC=0.1μF	0.5	1.0	1.5	S
Overdischarge reset dead time	TDCDC2	CDC=0.1μF	0.5	1.0	1.5	S
Battery voltage monitor output voltage ratio	VBMON	$\frac{(BATH-GND) \div 3}{VBATT}$	-1.0	0	1.0	%
Battery voltage monitor output current	ILMON		50			μA

Timing Chart

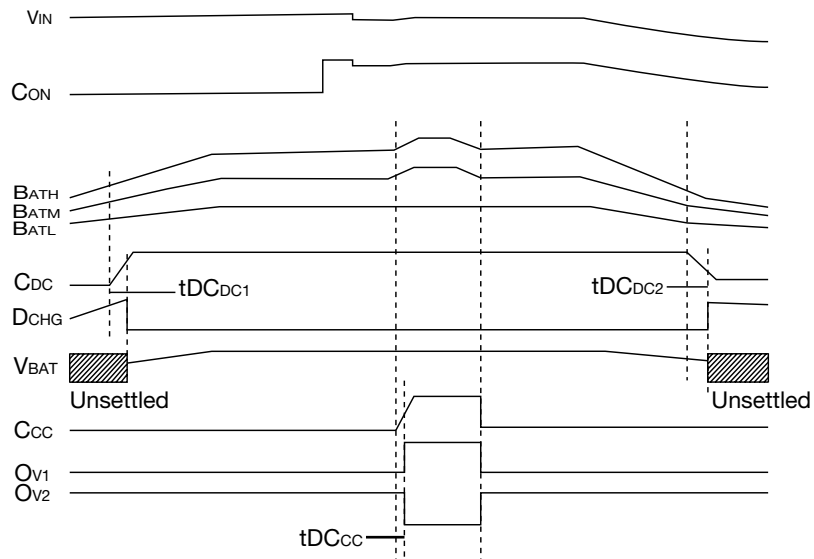

Block Diagram

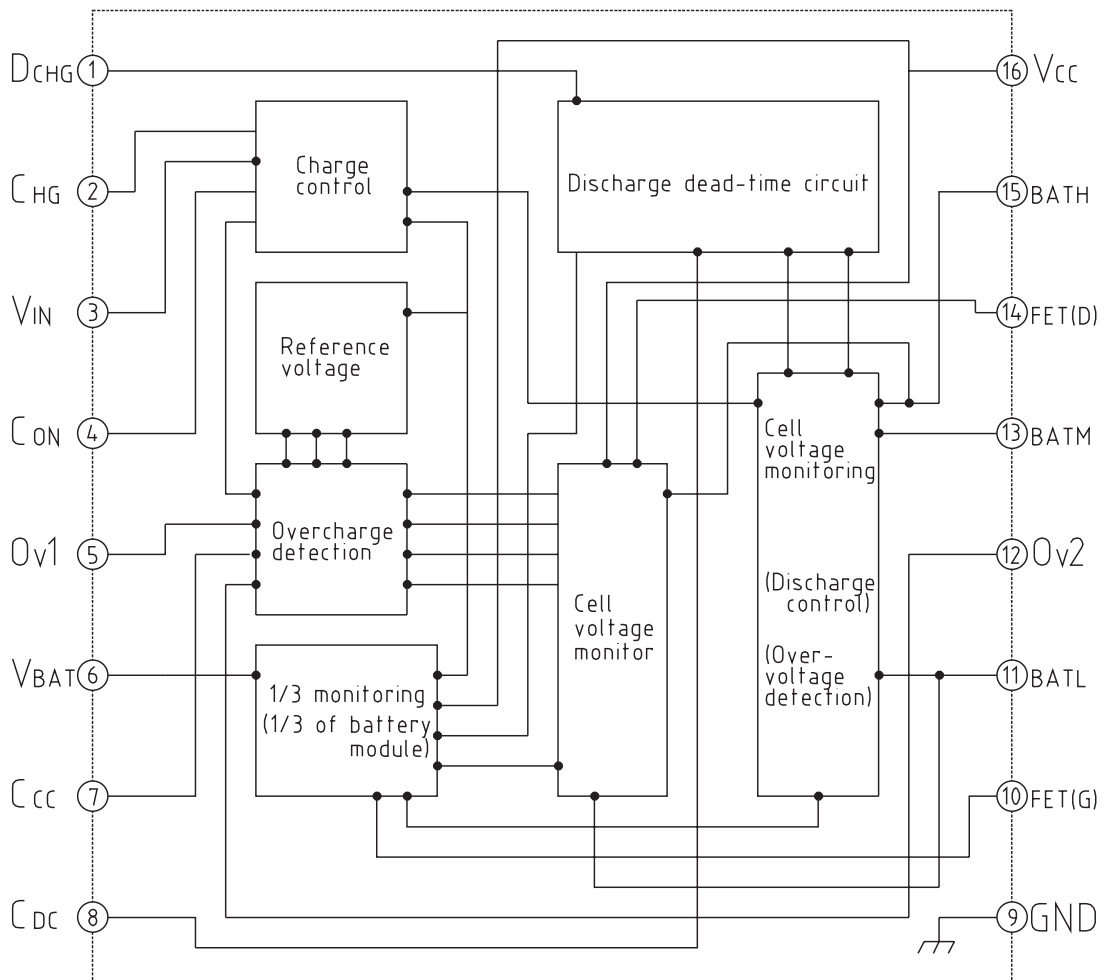

Application Circuits

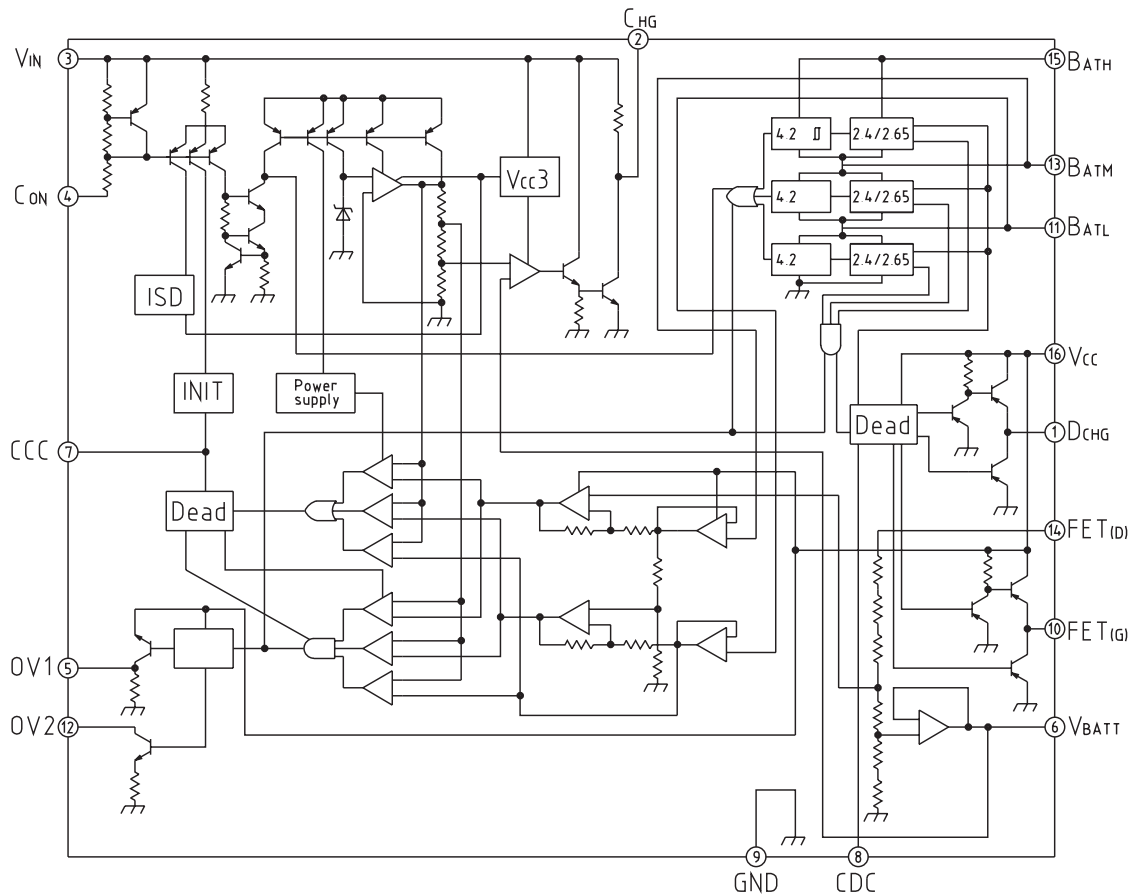
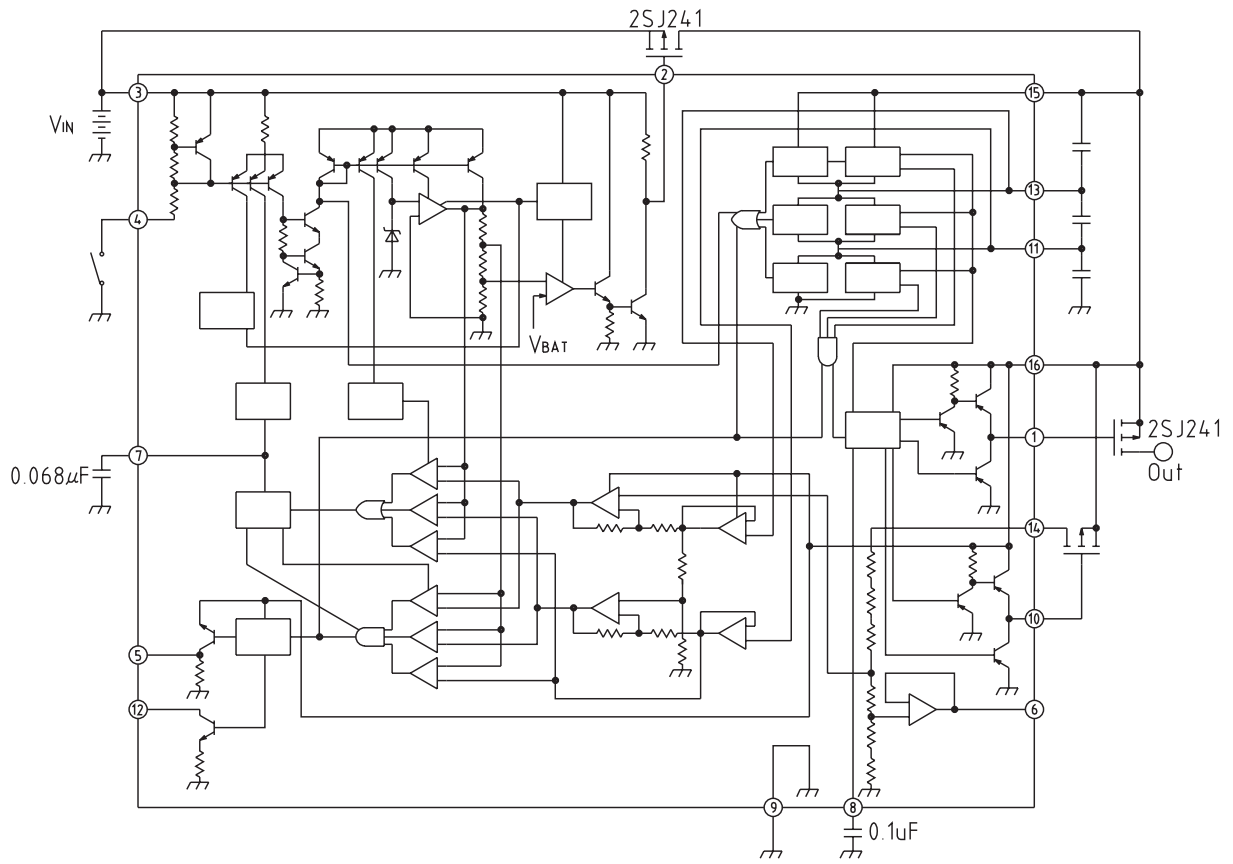

Circuit conventions

- Charge control unit
- Overcharge detection unit
 - Subtraction amp, buffer amp, voltage comparator, dead time setting circuit
- Discharge control unit
 - Cell voltage monitoring circuit, dead time setting circuit
- Overvoltage sensing (rough detection) unit
- High-precision reference voltage unit

Operating outline

1. Charge control

Charge control is turned on and off using the CON pin; when CON is low the charge control unit is in operation. The error amp of the charge control unit takes inputs of 4.155V from the high-precision reference voltage unit and the battery module voltage monitor output. The battery module voltage monitor outputs a voltage equal to 1/3 the battery module voltage, so that in charging control the charging control FET (pin 2) is controlled such that the battery module voltage is 4.155×3 V.

This block performs constant-voltage control only; current limiting (constant-current control) should be implemented on the charging input side.

2. Overcharge detection

There are two blocks for overcharge detection; three output modes are provided according to input conditions and cell voltage.

1. Charging signal on (during discharge)
2. Charging signal off (during discharge)
3. Discharge off

2-1. Charging signal on

The high-precision overcharge sensing unit is always in the operating state, and the voltage of each cell is monitored.

In order to monitor each cell's voltage precisely, subtraction amps are provided for monitoring M and H cell voltages, and a buffer amp is used to monitor the L cell voltage. By means of these amps the voltage of each cell is converted to a GND-reference voltage, and compared with the high-precision reference voltage of 4.335V.

If the voltage of any one of the cells exceeds 4.335V, the overvoltage is sensed, and the dead time setting pin (CCC pin 7) is charged by a constant current; when the CCC pin is charged to the threshold voltage of the dead time setting circuit (4.35V), an overvoltage signal is output.

(OV1 pin "H", OV2 pin "L")

When an overcharge signal is output, the overvoltage monitoring unit switches from the overvoltage state to the reset monitoring state, and an overcharge signal is output until the voltages of all cells fall to 4.16 V. To summarize the sequence of operations, when the voltage of any of the cells remains in the overcharge state continuously for the specified time (the dead time), that cell is judged to be in an overcharged state and is switched to overvoltage output; when all the cell voltages drop to the overcharge reset voltage or below, the overcharge state is canceled.

On entering the overcharge state, if the charge control unit circuit is turned off, the latter unit will not operate.

Pin	Output logic		Output type
	Normal	Overvoltage	
OV1	L	H	PNP output, internal pull-down resistance
OV2	High impedance	L	NPN open-collector output

2.2. Charging signal off

When the charging signal is off (CON pin "H"), the high-precision overvoltage sensing unit is in standby state. A rough overcharging sensing unit is provided internally to sense the overvoltage in this state. The rough overcharging sensing unit monitors the voltages of each cell, and if the voltage of any cell rises to or exceeds 4.2V, triggering overvoltage sensing (rough), the high-precision overcharging sensing unit enters the operating state.

Thereafter operation is the same as in "(2-1) Charging signal on" above.

2-3. Discharge off

In an overdischarge state, if the rough overvoltage detection voltage for any cell reaches or exceeds 4.2V, an overvoltage signal is output.

Hence in this case a dead time is not set. Further, reset depends on the hysteresis voltage at the time of rough overvoltage detection.

3. Discharge control

Voltage monitoring for discharge control is performed for each cell; if the voltage of any cell falls to 2.4V or less, the dead time setting pin (CDC pin 8) is discharged, and if the voltage drops to the discharge-off threshold voltage, an overdischarge state is detected and the discharge switch gate pin (pin 1) is set "H" and the battery module monitor unit input gate (pin 10) is also set "H"; the battery module monitor output impedance goes high.

At this time the monitoring circuit switches to a low consumption current (1µA typ. when all cell voltages are 2.4V), and the state switches from overdischarge to the reset monitoring state (with reset occurring when all cell voltages reach 2.65V).

Reset from the overdischarge state occurs when the CDC pin is charged under constant current after all cell voltages have reached 2.65V; when this pin reaches the threshold voltage for overdischarge reset, discharge is again turned on.

The dead time setting block of the discharge control unit has a circuit configuration such that if either the overdischarge or the reset state continues for longer than the set time, the state is switched. Hence when the state changes within the set time, the CDC pin undergoes rapid charging or discharging.

4. Battery module voltage monitor output

This block outputs a voltage equal to 1/3 the voltage of the battery module; within the IC, it is used as the charge control input. One-third the battery module voltage is supplied by a bleeder resistance, but in order to reduce the consumption current on overdischarge, a switch is provided such that current does not flow through this resistance when overdischarge occurs. The charging voltage and overvoltage detection are both highly precise, and so this switch is designed to use an external FET.

When battery voltage information is to be input to a microcomputer, this feature may be used, but with the following caveats regarding use.

1. The output upon overdischarge is at high impedance.
2. The output sink current is small.

In order to reduce the consumption current, the output sink current is held low; but depending on the external components used, response may be slow, affecting charging control and resulting in oscillation under constant-voltage control. In such cases, a resistance (of about 300kΩ) should be inserted between the monitor output and GND, to boost the sink capacity.

Pin Assignment

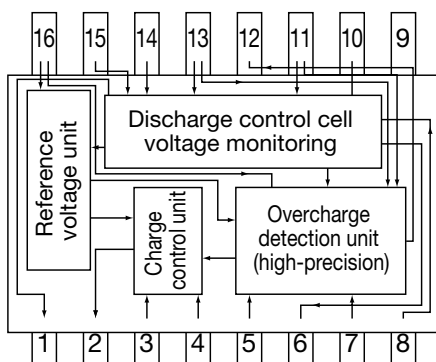

1	DCHG	9	GND
2	CHG	10	FET (G)
3	V _{IN}	11	BATL
4	CON	12	OV2
5	OV1	13	BATM
6	V _{BAT}	14	FET (D)
7	CCC	15	BATH
8	CDC	16	V _{CC}

Pin Description

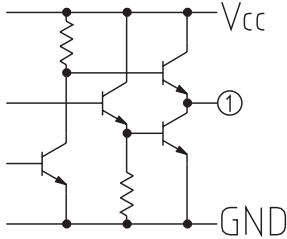
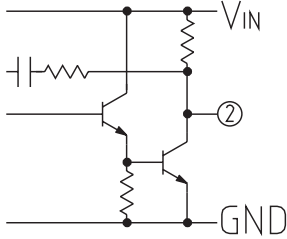
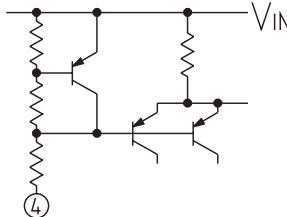
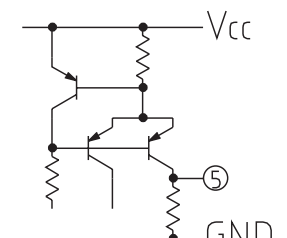
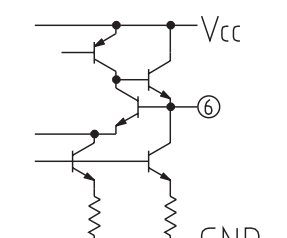
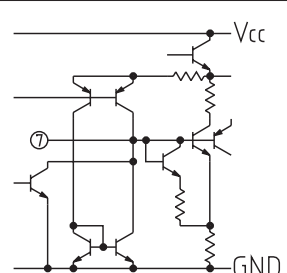
Pin no.	Pin name	Equivalent circuit	Function
1	DCHG		Pch-FET gate connector pin for discharge control "L" output during discharge, "H" when discharge is stopped
2	CHG		Pch-FET gate connector pin for charge control Feedback loop for constant-voltage control formed during charging; "H" output when charging is stopped When overvoltage or overheating is sensed (during charging), the gate is turned off ("H" level).
3	V _{IN}		Power supply input pin for the charge control unit
4	CON		Input pin for charge control signal. Input "L" to turn charging on, "H" to turn charging off (when open, charging is off)
5	OV1		Overvoltage signal output pin. PNP output, with internal pull-down resistance (50 kΩ typ.) "L" output in normal operation, "H" output on overvoltage
6	V _{BAT}		On discharge, 1/3 the battery module voltage is output; when discharge stops, switches to high-impedance output
7	CCC		Pin for connection to a capacitor to set the dead time for overcharge detection Normal operation : GND level; overcharge : approx. 5V Dead time is approx 1S for an 0.068μF capacitance

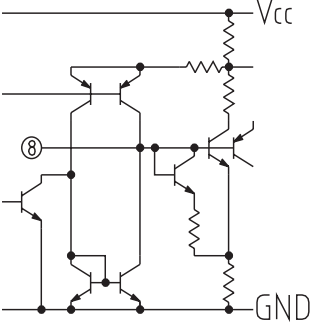
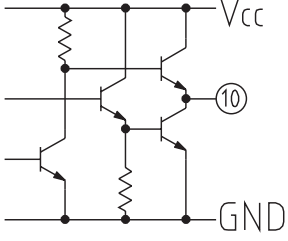
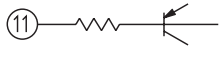
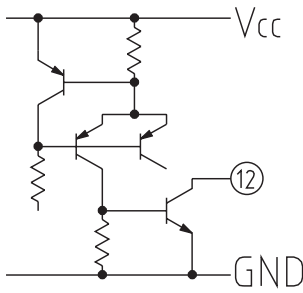
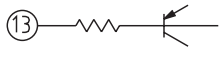
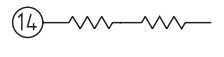
Pin no.	Pin name	Equivalent circuit	Function
8	CDC		Pin for connection to a capacitor to set the dead time for discharge on/off switching During discharge : approx. 5V; when discharge stops : GND level Dead time is set when discharge is turned off and discharge stopped Dead time is approx. 1S for an 0.1μF capacitance
9	GND		GND pin for this IC
10	FET (G)		Pin for connection to P-ch FET gate for battery module voltage level input During discharge "L" is output; when discharge is stopped switches to "H"
11	BATL		Pin for input of L cell+terminal voltage (in a battery module with three cells in series, cells are defined, starting from the high side, as the H cell, M cell and L cell)
12	OV2		Pin for overvoltage signal output; NPN open collector output High-impedance output during normal operation; switches to "L" on overcharge The high-potential side of the pull-up resistance should be 10 V max
13	BATM		Pin for input of M cell+terminal voltage
14	FET (D)		Pin for connection to drain of P-ch FET for battery module voltage level input
15	BATH		Pin for input of H cell+terminal voltage
16	Vcc		Power supply input pin for overcharge detection, discharge control, battery module voltage monitoring units Voltage at same potential as BATH should be input