

MITSUBISHI (DIGITAL ASSP)
M66516FP

LASER-DIODE DRIVER/CONTROLLER

DESCRIPTION

The M66516 is a semiconductor laser-diode driver/controller. Its functions are the driving and laser power control of a specific type (Mitsubishi's R type laser) of semiconductor laser diode, in which the cathode of a semiconductor laser diode is connected in stem structure to the anode of a monitoring photodiode.

The IC has a laser drive current output pin of source type and is capable of driving a laser diode on a maximum bias current of 30mA and a maximum switching current of 120 mA, which is switched at a rate of 20Mbps/sec.

Since the M66516 has a built-in sample-hold circuit, it is possible to realize an internal APC* system that requires no external device for laser power control.

*: Automatic Power Control

FEATURES

- Built-in sample-hold circuit for APC function
- High speed switching (20Mbps)
- Large drive current (150mA max.)
- Capable of setting bias current (30mA max.)
- 5V single power supply

APPLICATION

Semiconductor laser-diode applied equipment

PIN CONFIGURATION (TOP VIEW)

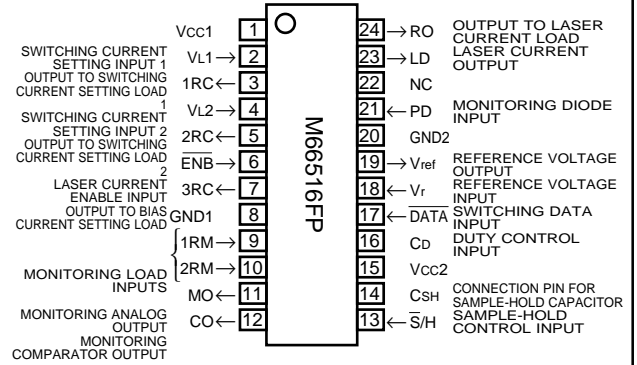

Outline 24P2N-B

NC: No Connection

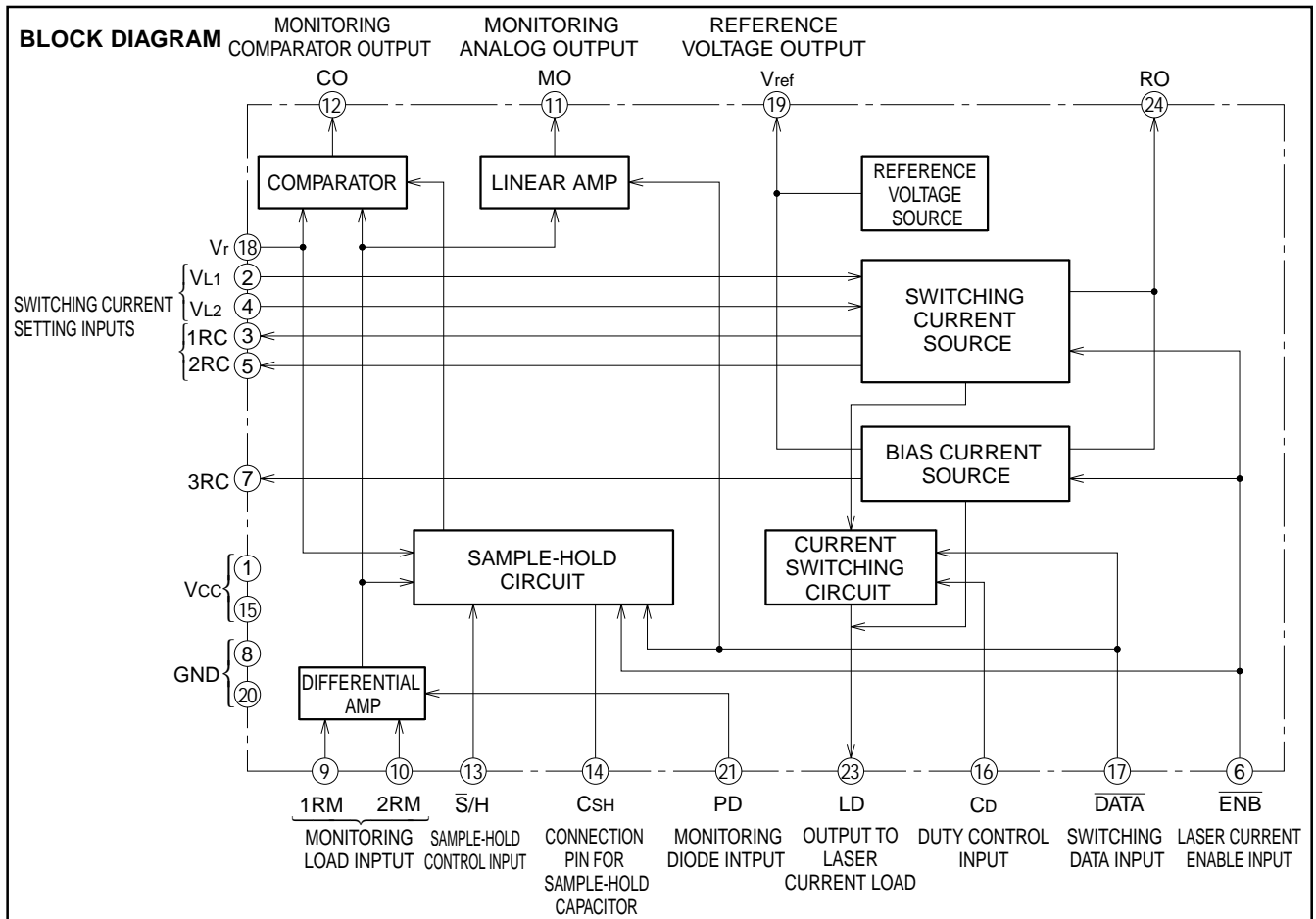

PIN DESCRIPTIONS

Pin	Name	Description
LD	Laser current output	Connect to anode on semiconductor laser diode.
PD	Monitoring diode input	Connect to cathode on monitoring photodiode.
VL1	Switching current setting input 1	Voltage input to set output current (IL1) of current source 1.
1RC	Output to switching current setting load 1	Connect load resistor between this pin and GND for IL1 setting.
VL2	Switching current setting input 2	Voltage input to set output current (IL2) of current source 2.
2RC	Output to switching current setting load 2	Connect a load resistor between this pin and GND for IL2 setting.
3RC	Output to bias current setting load	Connect a load resistor between this pin and GND for setting IB (bias current). Leave this pin open if IB is not used.
$\overline{\text{DATA}}$	Switching data input	If this pin is "L," a current of IL1 + IL2 + IB flows through laser diode; if "H," current IB flows.
1RM, 2RM	Monitoring load input	Connect a load resistor between pins 1RM and 2RM for conversion of current generated by monitoring photodiode into changes in voltage.
MO	Monitoring analog output	If $\overline{\text{DATA}} = \text{"L"}$ the potential difference generated on monitoring load resistor from photodiode monitoring current is output as a voltage referenced to GND. If $\overline{\text{DATA}} = \text{"H"}$ the output at this pin is fixed at "H" saturation level.
CO	Monitoring comparator output	The potential difference generated on monitoring load resistor from photodiode monitoring current is compared with the voltage on pin Vr. The result of the comparison is output in TTL level. This pin acts as comparator output pin only when $\overline{\text{S/H}} = \text{"H"}$ and $\overline{\text{DATA}} = \text{"L"}$. In other states, this output pin is fixed to "H."
$\overline{\text{ENB}}$	Laser current enable input	If this pin is "H," all current supply circuits are turned off.
RO	Laser current load output	Connect a laser current load resistor between this pin and Vcc.
CD	Duty control input	Connect a capacitor between this pin and GND for duty correction of light intensity switching waveforms. If duty correction is not required, leave this pin open.
$\overline{\text{S/H}}$	Sample-hold control input	In internal APC mode, if this pin is "L," sampling (APC) occurs, if "H," holding (switching). In external APC mode, connect this pin to Vcc.
CSH	Connection pin for sample-hold capacitor	Connect a capacitor for sample-hold function between this pin and GND.
Vref	Reference voltage output	Internal reference voltage (1.2V typ.) output pin of M66516
Vr	Reference voltage input	A reference voltage is applied to this pin to operate the comparator and the sample-hold circuit. Connect this pin to the Vref pin if the internal reference voltage of the M66516 is used.
Vcc1		Power supply for internal analog circuits. Connect to a positive power source (+5V).
Vcc2		Power supply for internal digital circuits. Connect to a positive power source (+5V).
GND1		GND for internal analog circuits.
GND2		GND for internal digital circuits.

OPERATION

1. Settings for Laser Drive Currents

The M66516 has built-in current sources for switching, IL1 and IL2, and a bias current source, IB. Each output current can be controlled independently.

Approximate equations used for determining the current output from each of these current sources are as follows.

(1) IL1

IL1 is determined by the voltage on the VL1 pin and the resistor (RC 1) connected between the 1RC pin and GND.

The following equation is used for approximation.

$$IL1 [mA] = 12 \times \frac{VL1 [V]}{RC1 [k\Omega]}$$

(2) IL2

IL2 is determined by the voltage on the VL2 pin and the resistor (RC 2) connected between the 2RC pin and GND.

The following equation is used for approximation.

$$IL2 [mA] = 12 \times \frac{VL2 [V]}{RC2 [k\Omega]}$$

(3) IB

IB is determined by the internal reference voltage (Vref) and the resistor (RC 3) connected between the 3RC pin and GND.

The following equation is used for approximation.

$$IB [mA] = 10 \times \frac{Vref [V]}{RC3 [k\Omega]}$$

2. Laser Drive Current Switching Operation

If $\overline{DATA} = "L,"$ laser drive current is IL1 + IL2 + IB; if $\overline{DATA} = "H,"$ IB.

3. Laser Power Monitoring Operation

At the MO and CO pins, the M66516 outputs data obtained by the monitoring photodiode (PD) contained in laser, in the sequence explained below.

(1) A current equal to the PD current generated from laser light flows through the resistor (RM) inserted between 1RM and 2RM. Thence a potential difference (VM) occurring on RM is converted by the internal differential amp. to a level from GND.

(2) VM is output at the MO pin as an analog signal through a buffer amp. At the same time, the comparator compares VM with the voltage applied to the Vr pin, then the result of the comparison is output at the CO pin in TTL level.

If $VM < Vr,$ CO output = "L"; and if $VM > Vr,$ CO output = "H."

As the condition of the above operation, both the MO and CO output circuits should be in monitoring operation. See the table below.

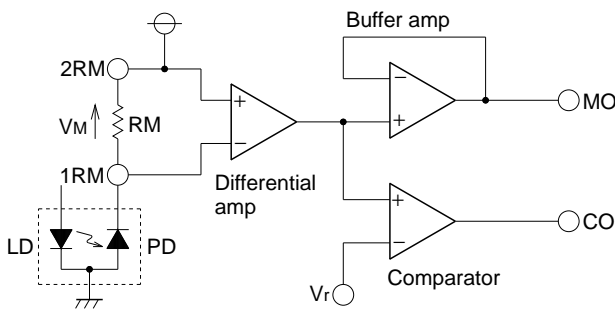

A Schematic Diagram of Monitor Circuits

Monitor Function Table

Input		Output	
$\overline{S/H}$	\overline{DATA}	MO output	CO output
L	L	Analog output	Fixed to "H"
L	H	"H" saturation	Fixed to "H"
H	L	Analog output	Comparator output
H	H	"H" saturation	Fixed to "H"

4. RO Pin

A load resistor for laser drive current is connected to the RO pin, through which a current almost equal to laser drive current flows in (when $\overline{DATA} = "H"$). A load resistor is connected between the RO pin and V_{CC} to reduce power dissipated in the IC.

Due to reasons related to the operation of circuits, the voltage at this pin should be 3.5V or higher.

Consequently, the maximum resistance, $RO_{(max.)}$, of load resistor RO is:

$$RO_{(max.)} (\Omega) = \frac{V_{CC (min.)} - 3.5 [V]}{ILD_{(max.)} [A]}$$

where $ILD_{(max.)}$ is the maximum of laser drive current. If, for

example, $V_{CC (min.)} = 4.75 V$ and $ILD_{(max.)} = 150 mA$, $RO_{(max.)} = 8.3 \Omega$. Accordingly, if the resistances of RC 1 to RC 3 is selected so as to gain a maximum laser drive current of 150mA, RO should be 8.3Ω at the maximum.

5. \overline{ENB} Input

If laser current is controlled by the \overline{DATA} input, the current source circuit is in operation even with zero laser current. If \overline{ENB} input = "H", all current source circuits go off including the bias current source.

6. APC Operation

(1) Sample-hold circuit

The following are a conceptual diagram and function table of the sample-hold circuit contained in the M66516.

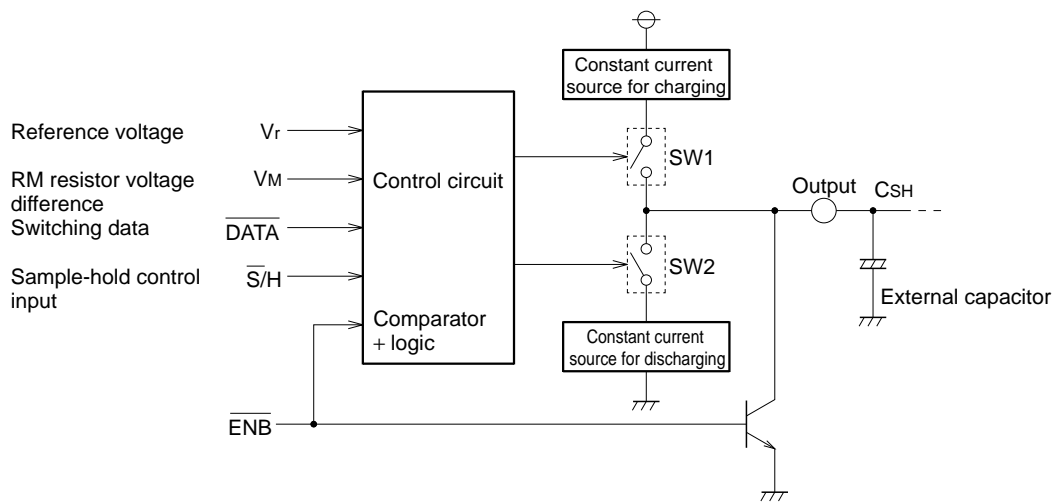

Conceptual Diagram: Sample-Hold Circuit

Function Table

Input				Switch condition		Output
\overline{ENB}	$\overline{S/H}$	\overline{DATA}	V_M, V_r	SW1	SW2	
H	x	x	x	OFF	OFF	Fixed to "L"
L	H	x	x	OFF	OFF	High impedance state (hold)
L	L	H	x	OFF	OFF	High impedance state (hold)
L	L	L	$V_M < V_r$	ON	OFF	Constant current sourcing (sample)
			$V_M > V_r$	OFF	ON	Constant current sinking (sample)

x: Don't care

(2) External voltage-applied APC circuit

The following figure is an example of APC circuit configuration, in which voltages are applied from external sources to the VL1 and VL2 input pins of the M66516. In this example, the

\overline{S}/H input pin is connected to Vcc and the Csh pin is open. The CO or MO output is used to monitor laser power for adjustment of external control voltage.

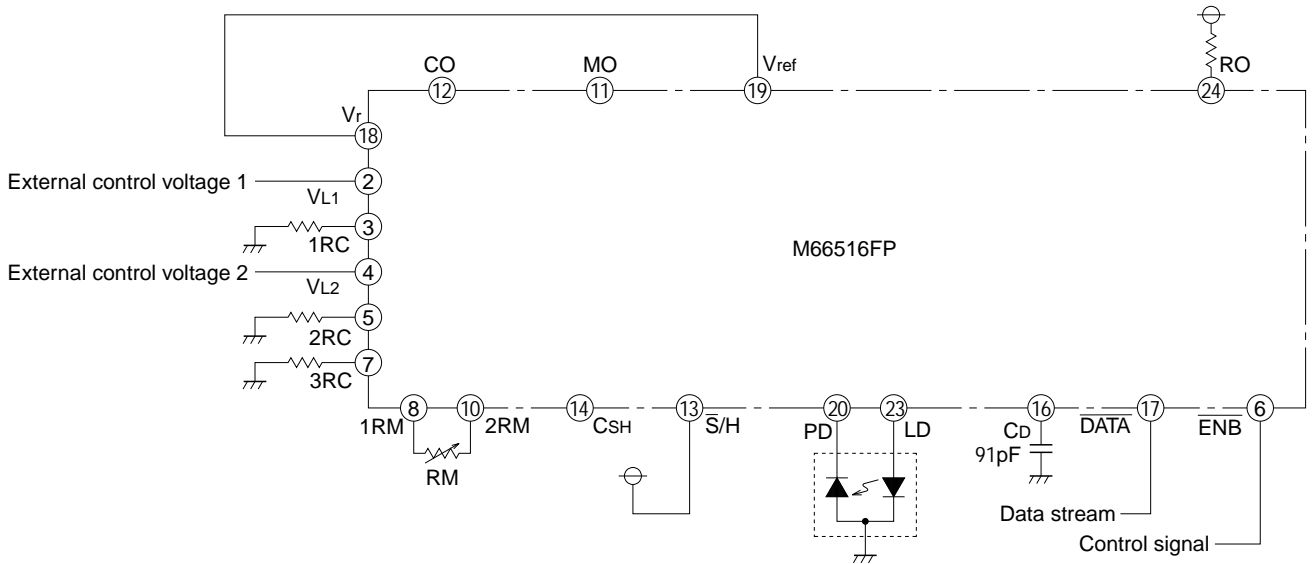

(3) Peak-holding internal APC circuit

The following figure is a configuration example of peak-holding internal APC circuit. In this example, the \overline{S}/H input pin is connected to GND.

If laser power is lower than preset value, C1 is charged with the current from the Csh output pin through D1. The charge stored in C1 is discharged through R1 thereafter.

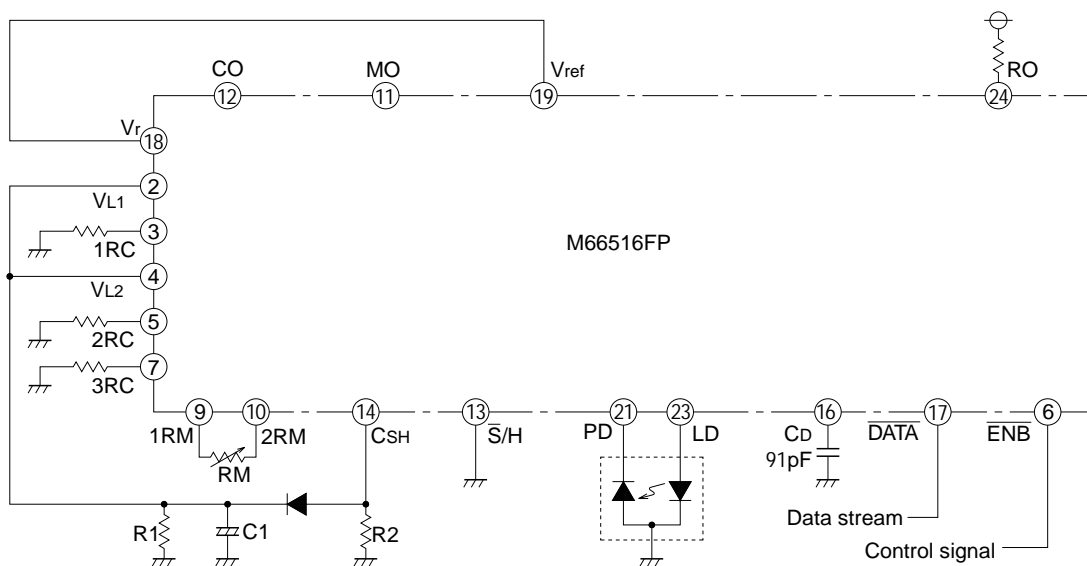

C1, R1: Time constant components
 R2: Pull-down resistor
 (Used for establishing Csh line voltage in case that Csh is in high impedance condition.)

(4) Sample-hold type internal APC circuit

The following figure is a configuration example of sample-hold type internal APC circuit. In this example, a sample-hold control signal is applied to the $\overline{S/H}$ input pin.

In a sampling state, if laser power is lower than preset value,

C1 is charged by current from the CSH output pin, while if it is higher than preset value, C1 is discharged.

In a holding state, the CSH output is in high-impedance condition.

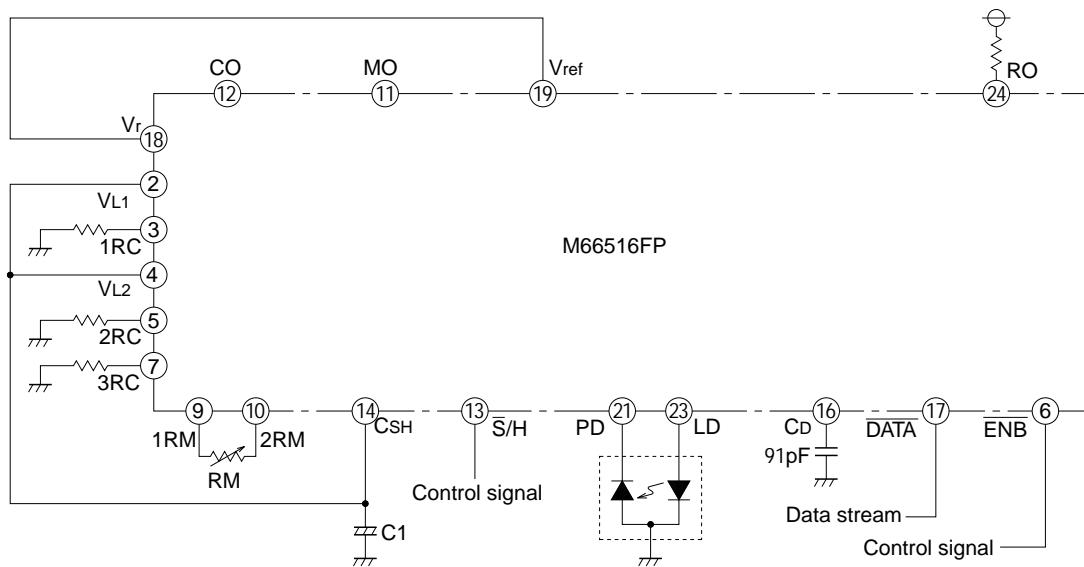

C1: Capacitor for sample-hold function

ABSOLUTE MAXIMUM RATINGS ($T_a = -20 \sim 75^\circ\text{C}$, unless otherwise noted)

Symbol	Parameter	Conditions	Ratings	Unit
V _{CC}	Supply voltage		-0.5 ~ +7.0	V
V _I	Input voltage	V _{L1} , V _{L2} , V _r	-0.3 ~ V _{CC}	V
		DATE, ENB, S/H	-0.3 ~ +7.0	
V _O	Output voltage	CO	"H" Output -0.3 ~ +5.5	V
		RO	"H" Output -0.3 ~ +7.0	
I _{L1}	Output current 1		-90	mA
I _{L2}	Output current 2		-90	mA
I _B	Bias current		-45	mA
P _d	Power dissipation	Measured being mounted T _a = 25°C (Note 1)	890	mW
T _{stg}	Storage temperature		-60 ~ 150	°C

SWITCHING CHARACTERISTICS ($T_a = -20 \sim 75^\circ\text{C}$, unless otherwise noted)

Symbol	Parameter	Conditions	Limits			Unit
			Min.	Typ.	Max.	
V _{CC}	Supply voltage		4.75	5.0	5.25	V
I _{L1}	Output current 1				-60	mA
I _{L2}	Output current 2				-60	mA
I _B	Bias current				-30	mA
T _{opr}	Operational ambient temperature		-20		75	°C

Note 1: When $T_a \geq 25^\circ\text{C}$, derate by 7.1mW/°C

ELECTRICAL CHARACTERISTICS (Ta = -20 ~ 75°C, Vcc = 5V±5%, unless otherwise noted)

Symbol	Parameter		Test conditions	Limits			Unit
				Min.	Typ. ⁽²⁾	Max.	
V _{IH}	"H" Input voltage	$\overline{\text{DATA}}$, $\overline{\text{ENB}}$, $\overline{\text{S/H}}$		2.0			V
V _{IL}	"L" Input voltage	$\overline{\text{DATA}}$, $\overline{\text{ENB}}$, $\overline{\text{S/H}}$				0.8	V
V _I	Maximum effective Input voltage	V _{L1} , V _{L2}		V _{CC} - 1.8	V _{CC} - 1.4		V
V _{OH}	"H" Output voltage	CO	I _{OH} = -400μA	2.7			V
V _{OL}	"L" Output voltage	CO	I _{OL} = 4mA			0.4	V
			I _{OL} = 8mA			0.5	
V _{OH}	"H" Output voltage	C _{SH}	$\overline{\text{ENB}}$ = 0.8V, I _{OH} = -2mA	4.0			V
V _{OL}	"L" Output voltage	C _{SH}	$\overline{\text{ENB}}$ = 0.8V, I _{OH} = 2mA			0.6	V
V _{LD}	Ambient temperature	LD				2.5	V
V _{OS}	Output offset voltage	MO	I _{MO} = ±20μA (3)		30		mV
ΔV _M	Output voltage fluctuation	MO	I _{PD} = -0.2 ~ 2.0mA I _{MO} = ±20μA, R _M = 1kΩ (4)		20		mV
		Temperature coefficient	I _{PD} = -1.2mA		0.05		mV/°C
I _I	Input current	$\overline{\text{DATA}}$, $\overline{\text{ENB}}$	V _I = 2.7V			20	μA
			V _I = 0.4V			-0.2	mA
		V _{L1} , V _{L2} , V _r	V _I = 0 ~ V _{CC}			±1	μA
V _{ref}	Reference voltage output	Temperature coefficient	I _O = -10μA		1.2		mV/°C
			Ta = -20 ~ 25°C		-1.5		
V _r	Reference voltage input			0.4		2.0	V
I _{L1}	Output current 1 (5)	LD	V _{L1} = 3V, V _{L2} = 0V, V _{LD} = 2V, RC1 = RC2 = 560Ω, RC3 open			-62	mA
						Temperature coefficient	
I _{L2}	Output current 2 (5)	LD	V _{L1} = 0V, V _{L2} = 3V, V _{LD} = 2V, RC1 = RC2 = 560Ω, RC3 open			-62	mA
						Temperature coefficient	
I _B	Bias current (5)	LD	RC3 = 360Ω, V _{LD} = 2V			-31	mA
I _{OFF}	OFF state output current	LD	$\overline{\text{ENB}}$ = 0.8V, $\overline{\text{DATA}}$ = 2V			-1	mA
			$\overline{\text{ENB}}$ = 2V, $\overline{\text{DATA}}$ = 0.8V			-20	μA
I _{cg}	Charge current	C _{SH}	V _O = 0.6 ~ 4.0V	-0.66		-2.0	mA
I _{dg}	Discharge current	C _{SH}	V _O = 0.6 ~ 4.0V	0.66		2.0	mA
I _{oz}	Output leak current	C _{SH}	V _O = 0 ~ V _{CC} , Hold condition			±8	μA
I _{CC}	Supply current	$\overline{\text{DATA}}$ = 0V	V _{CC} = 5.25V, $\overline{\text{ENB}}$ = 0V, V _{L1} = V _{L2} = 3V, RC1 = RC2 = 560Ω, RC3 = 360Ω output open			36	mA
		$\overline{\text{DATA}}$ = 4.5V				54	

Note 2: Typical values are gained under conditions of V_{CC} = 5V and Ta = 25°C. Regarding parameters that Ta is specified as test condition, however, typical values are gained under the condition V_{CC} = 5V.

3: I_{MO}: Output current at MO pin; I_{PD}: Input current at PD pin

4: R_M: Resistor inserted between 1R_M and 2R_M.

5: These parameters indicate the conversion characteristics of the input voltage and output current. In actual use, I_{L1}, I_{L2}, and I_B shall be within the range specified as limits in the recommended operating conditions.

SWITCHING CHARACTERISTICS (Ta = -25°C, Vcc = 5V)

Symbol	Parameter	Test pin		Test condition	Limits			Unit
		Input	Output		Min.	Typ.	Max.	
fop	Operating frequency					20		Mbps
tRP1	Circuit response time 1	VL1, VL2 voltage	LD current	ILD(L) = 0mA ILD(H) = -60mA(Note 6)			7	μs
				ILD(L) = -55mA ILD(H) = -65mA(Note 6)			2	μs
tRP2	Circuit response time 2	PD current	MO voltage	IPD(L) = 0mA IPD(H) = -2mA RM = 1kΩ (Note 7)			10	μs
				ΔIPD = 0.2mA RM = 1kΩ (Note 7)			3	μs
tRP3	Circuit response time 3	PD current	CO voltage	ΔIPD = 1mA (Note 7)			10	μs
				ΔIPD = 0.2mA (Note 7)			2	
tRP4	Circuit response time 4	DATA voltage	CSH voltage	IPD = 0mA, -2mA, RM = 1kΩ, Vr = 1.2V (Note 8)			8	μs
tON	Circuit ON time	ENB voltage	LD current	ILD(H) = -60mA(Note 9)			5	μs
tOFF	Circuit OFF time	ENB voltage	LD current	ILD(H) = -60mA(Note 9)			2	μs

NOTE 6: TEST CRICUTS

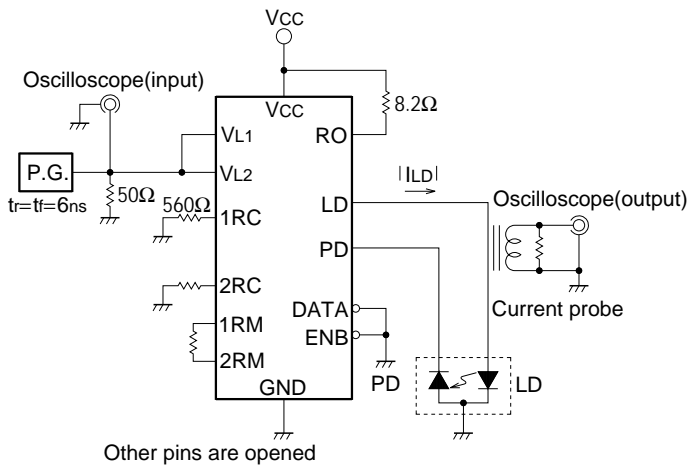

NOTE 7: TEST CRICUTS

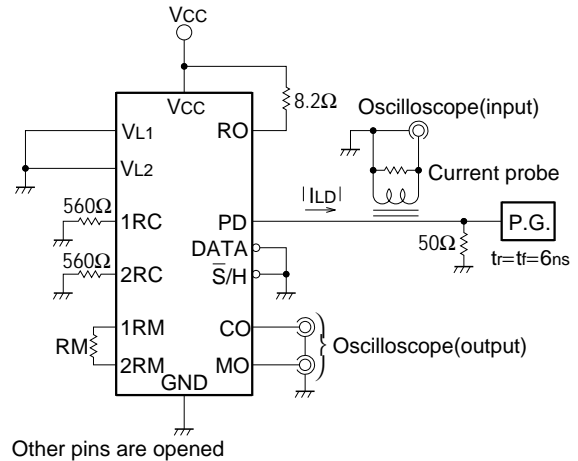

TIMING CHARTS

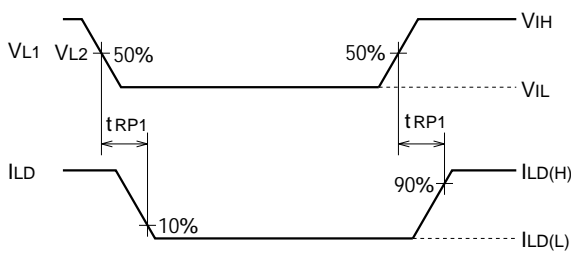

TIMING CHARTS

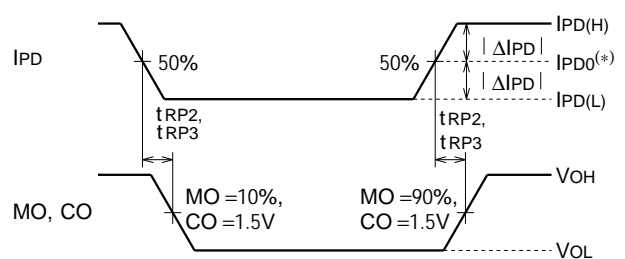

(*): IPD gained at the moment CH output is inverted.

NOTE 8: TEST CIRCUITS

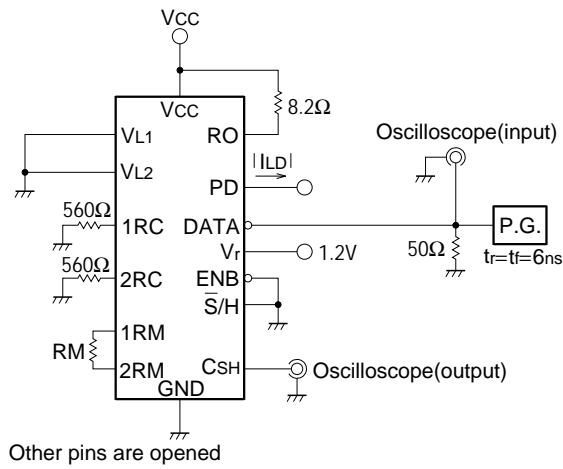

NOTE 9: TEST CIRCUITS

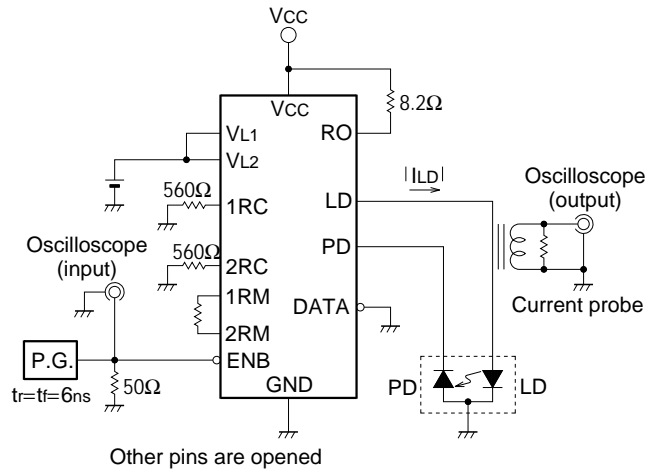

TIMING CHARTS

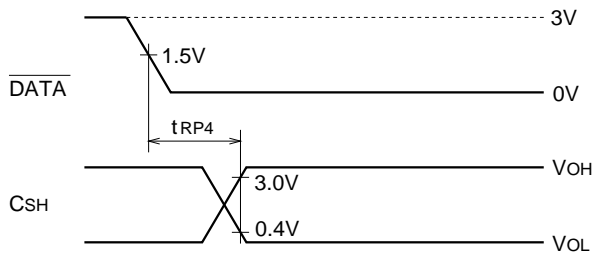

TIMING CHARTS

