



128K × 8 CMOS STATIC RAM

GENERAL DESCRIPTION

The W24010 is a normal-speed, very low-power CMOS static RAM organized as 131072 × 8 bits that operates on a wide voltage range from 2.7V to 5.5V power supply. The W24010 family, W24010-70LE and W24010-70LI, can meet the requirement of various operating temperature. This device is manufactured using Winbond's high performance CMOS technology.

FEATURES

- Low power consumption:
 - Active: 350 mW (max.)
 - Standby: 15 μW (max.) /3V
50 μW (max.) /5V
- Access time: 70 nS (max.) /5V
100 nS (max.) /3V
- Single 3V/5V power supply
- Fully static operation
- All inputs and outputs directly TTL compatible
- Three-state outputs
- Battery back-up operation capability
- Data retention voltage: 2V (min.)
- Packaged in 32-pin 600 mil DIP, 450 mil SOP, standard type one TSOP (8 mm × 20 mm) and small type one TSOP (8 mm × 13.4 mm)

PIN CONFIGURATIONS

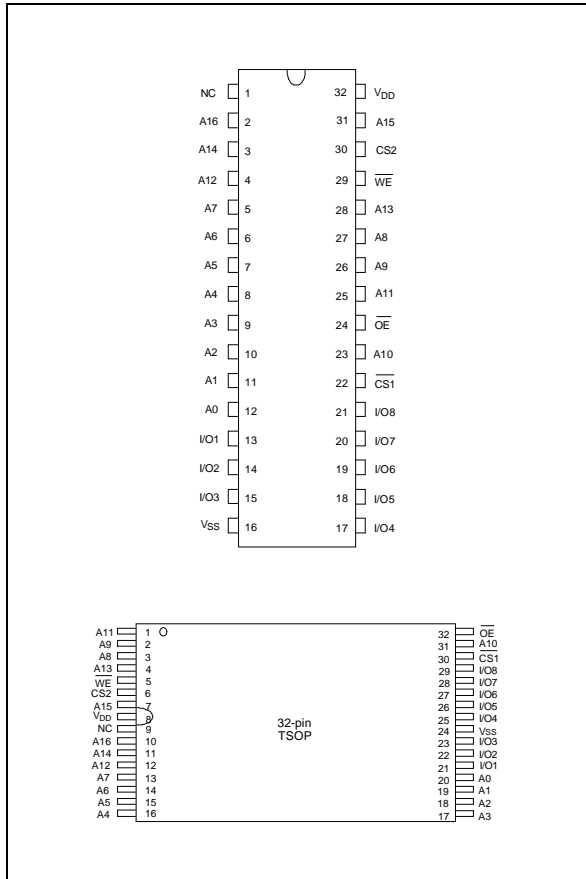

BLOCK DIAGRAM

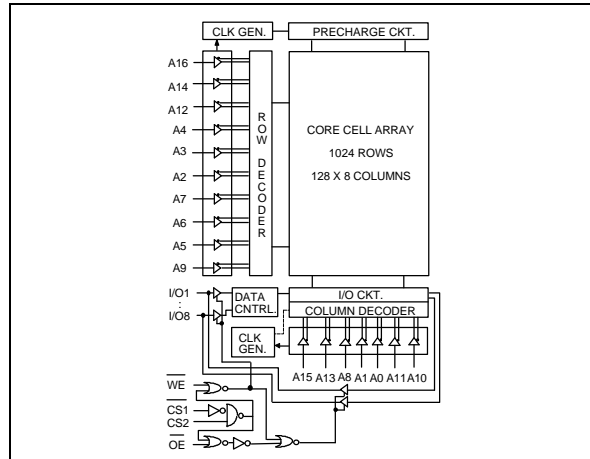

PIN DESCRIPTION

SYMBOL	DESCRIPTION
A0–A16	Address Inputs
I/O1–I/O8	Data Inputs/Outputs
CS1, CS2	Chip Select Input
WE	Write Enable Input
OE	Output Enable Input
VDD	Power Supply
VSS	Ground
NC	No Connection

TRUTH TABLE

CS1	CS2	OE	WE	MODE	I/O1 - I/O8	VDD CURRENT
H	X	X	X	Not Selected	High Z	ISB, ISB1
X	L	X	X	Not Selected	High Z	ISB, ISB1
L	H	H	H	Output Disable	High Z	IDD
L	H	L	H	Read	Data Out	IDD
L	H	X	L	Write	Data In	IDD

DC CHARACTERISTICS

Absolute Maximum Ratings

PARAMETER	RATING	UNIT
Supply Voltage to Vss Potential	-0.5 to +7.0	V
Input/Output to Vss Potential	-0.5 to VDD +0.5	V
Allowable Power Dissipation	1.0	W
Storage Temperature	-65 to +150	°C
Operating Temperature	LE	-20 to 85
	LI	-40 to 85

Note: Exposure to conditions beyond those listed under Absolute Maximum Ratings may adversely affect the life and reliability of the device.

Operating Characteristics

(VDD = 5V ±10%; VDD = 3V ±10%; VSS = 0V; TA (°C) = -20 to 85 for LE, -40 to 85 for LI)

PARAMETER	SYM.	TEST CONDITIONS	5V			3V			UNIT
			MIN.	TYP.*	MAX.	MIN.	TYP.*	MAX.	
Input Low Voltage	VIL	-	-0.5	-	+0.8	-0.5	-	+0.6	V
Input High Voltage	VIH	-	+2.2	-	VDD +0.5	+2.0	-	VDD +0.5	V
Input Leakage Current	ILI	VIN = VSS to VDD	-1	-	+1	-1	-	+1	µA
Output Leakage Current	ILO	VI/O = VSS to VDD, CS1 = VIH (min.) or CS2 = VIL (max.) or OE = VIH (min.) or WE = VIL (max.)	-1	-	+1	-1	-	+1	µA
Output Low Voltage	VOL	IOL = +2.1 mA	-	-	0.4	-	-	0.4	V
Output High Voltage	VOH	IOH = -1.0 mA	2.4	-	-	2.2	-	-	V



Operating Characteristics, continued

PARAMETER	SYM.	TEST CONDITIONS	5V			3V			UNIT
			MIN.	TYP.*	MAX.	MIN.	TYP.*	MAX.	
Operating Power Supply Current	I _{DD}	CS1 = V _{IL} (max.) and CS2 = V _{IH} (min.) I/O = 0 mA Cycle = min. Duty = 100%	-	-	70	-	-	30	mA
Standby Power Supply Current	I _{SB}	CS1 = V _{IH} (min.) or CS2 = V _{IL} (max.) Cycle = min. Duty = 100%	-	-	3	-	-	1	mA
	I _{SB1}	CS1 ≥ V _{DD} - 0.2V or CS2 ≤ 0.2V	-	1.0	10	-	0.5	5	μA

Note: Typical parameter is measured under ambient temperature T_A = 25° C and V_{DD} = 5V/ 3V

CAPACITANCE

(V_{DD} = 5 V, T_A = 25° C, f = 1 MHz)

PARAMETER	SYM.	CONDITIONS	MAX.	UNIT
Input Capacitance	C _{IN}	V _{IN} = 0V	6	pF
Input/Output Capacitance	C _{I/O}	V _{OUT} = 0V	8	pF

Note: These parameters are sampled but not 100% tested.

AC Characteristics

AC Test Conditions

PARAMETER	CONDITIONS
Input Pulse Levels	3V 0V to 2.4V
	5V 0V to 3.0V
Input Rise and Fall Times	5 nS
Input and Output Timing Reference Level	1.5V
Output Load	See the drawing below

AC Test Loads and Waveform

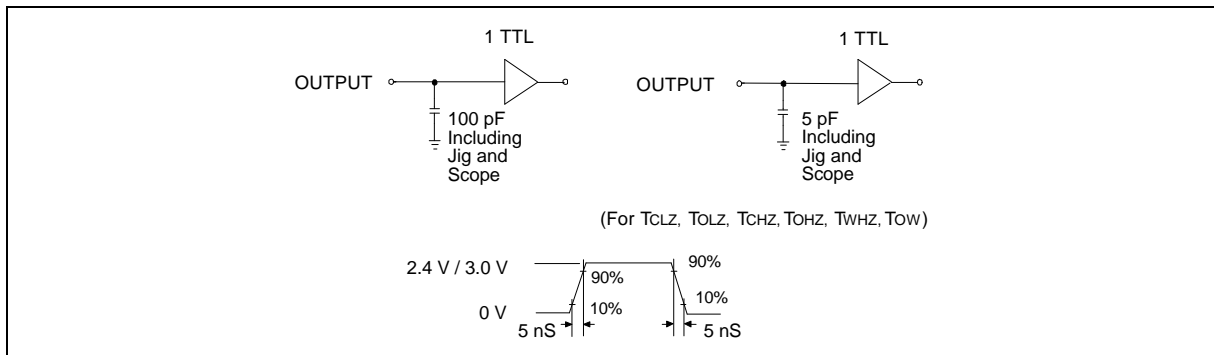



AC Characteristics, continued

(V_{DD} = 5 V ±10%; V_{DD} = 3 V ±10%; V_{SS} = 0 V; T_A (°C) = -20 to 85 for LE, -40 to 85 for LI)**Read Cycle**

PARAMETER	SYM.	5 V		3 V		UNIT
		MIN.	MAX.	MIN.	MAX.	
Read Cycle Time	TRC	70	-	100	-	nS
Address Access Time	TAA	-	70	-	100	nS
Chip Select Access Time	TACS	-	70	-	100	nS
Output Enable to Output Valid	TAOE	-	35	-	50	nS
Chip Selection to Output in Low Z	TCLZ*	10	-	15	-	nS
Output Enable to Output in Low Z	TOLZ*	5	-	5	-	nS
Chip Deselection to Output in High Z	TCHZ*	-	30	-	35	nS
Output Disable to Output in High Z	TOHZ*	-	30	-	35	nS
Output Hold from Address Change	TOH	10	-	15	-	nS

* These parameters are sampled but not 100% tested

Write Cycle

PARAMETER	SYM.	5 V		3 V		UNIT
		MIN.	MAX.	MIN.	MAX.	
Write Cycle Time	TWC	70	-	100	-	nS
Chip Selection to End of Write	TCW	50	-	70	-	nS
Address Valid to End of Write	TAW	50	-	70	-	nS
Address Setup Time	TAS	0	-	0	-	nS
Write Pulse Width	TWP	50	-	70	-	nS
Write Recovery Time	$\overline{CS1}, CS2, \overline{WE}$ TWR	0	-	0	-	nS
Data Valid to End of Write	TDW	30	-	50	-	nS
Data Hold from End of Write	TDH	0	-	0	-	nS
Write to Output in High Z	TWHZ*	-	25	-	30	nS
Output Disable to Output in High Z	TOHZ*	-	25	-	30	nS
Output Active from End of Write	TOW	5	-	10	-	nS

* These parameters are sampled but not 100% tested

TIMING WAVEFORMS

Read Cycle 1

(Address Controlled)

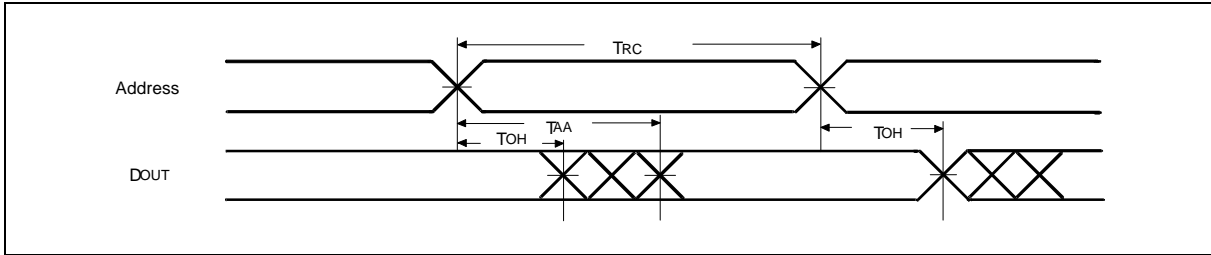

Read Cycle 2

(Chip Select Controlled)

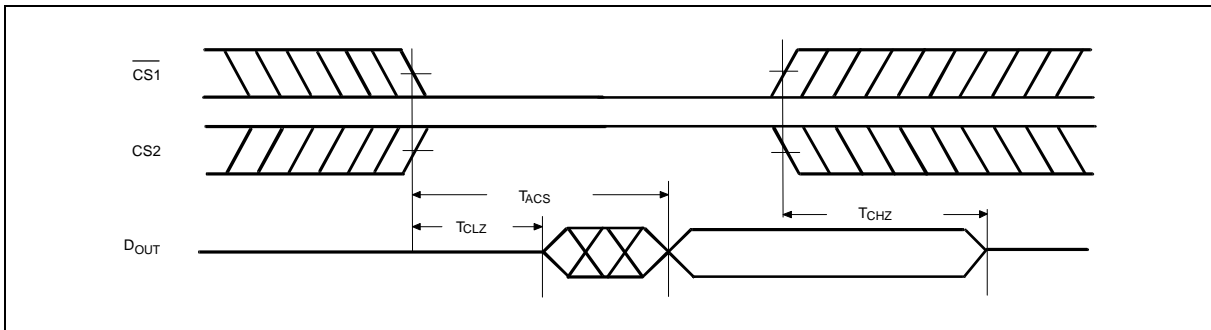

Read Cycle 3

(Output Enable Controlled)

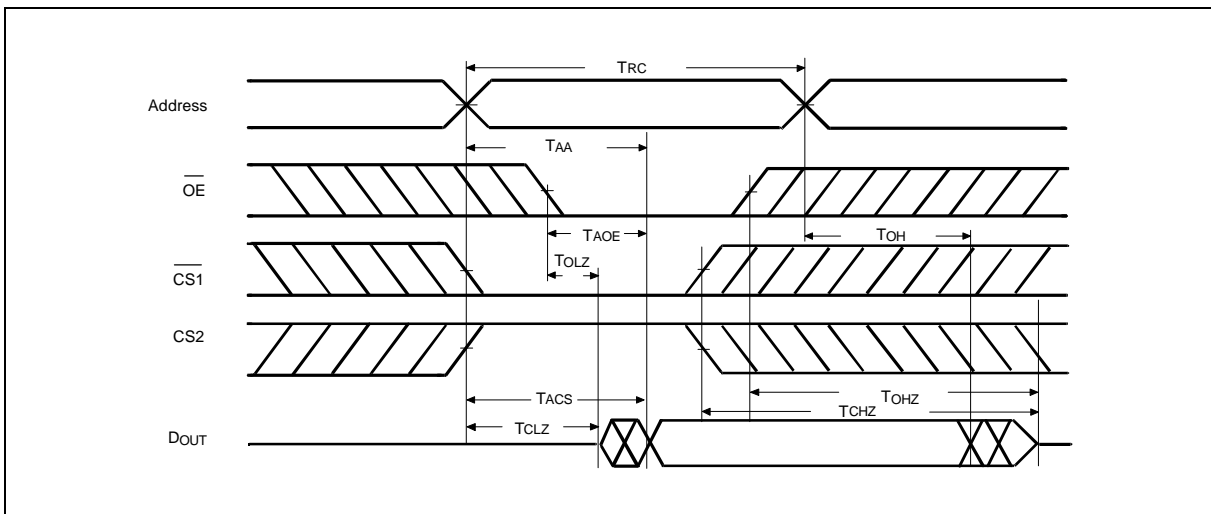

Timing Waveforms, continued

Write Cycle 1

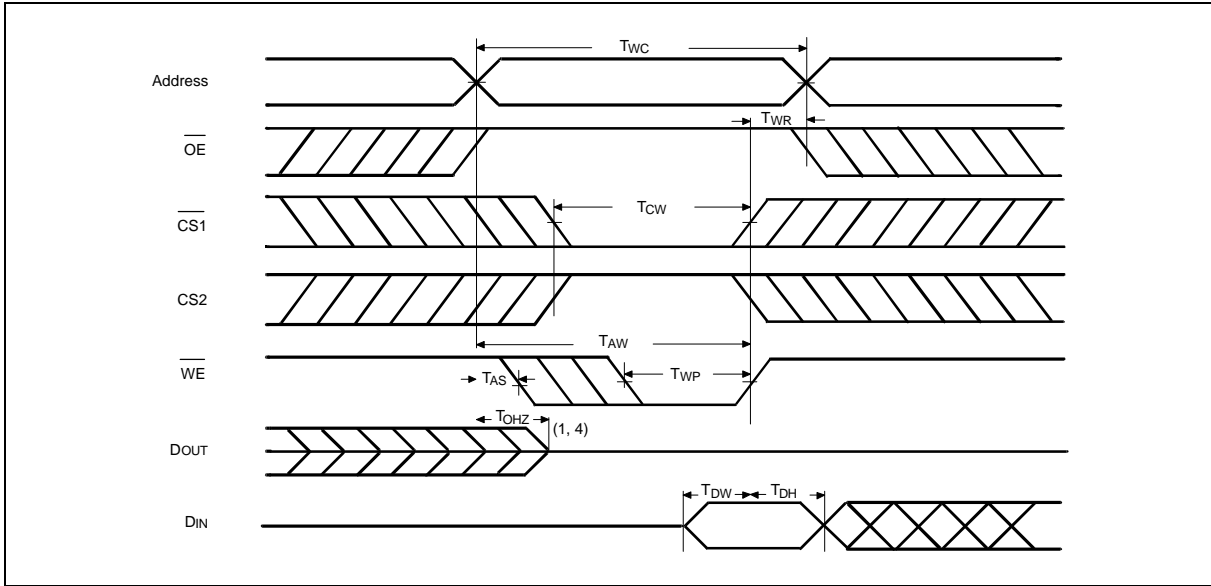

Write Cycle 2

($\overline{OE} = V_{IL}$ Fixed)

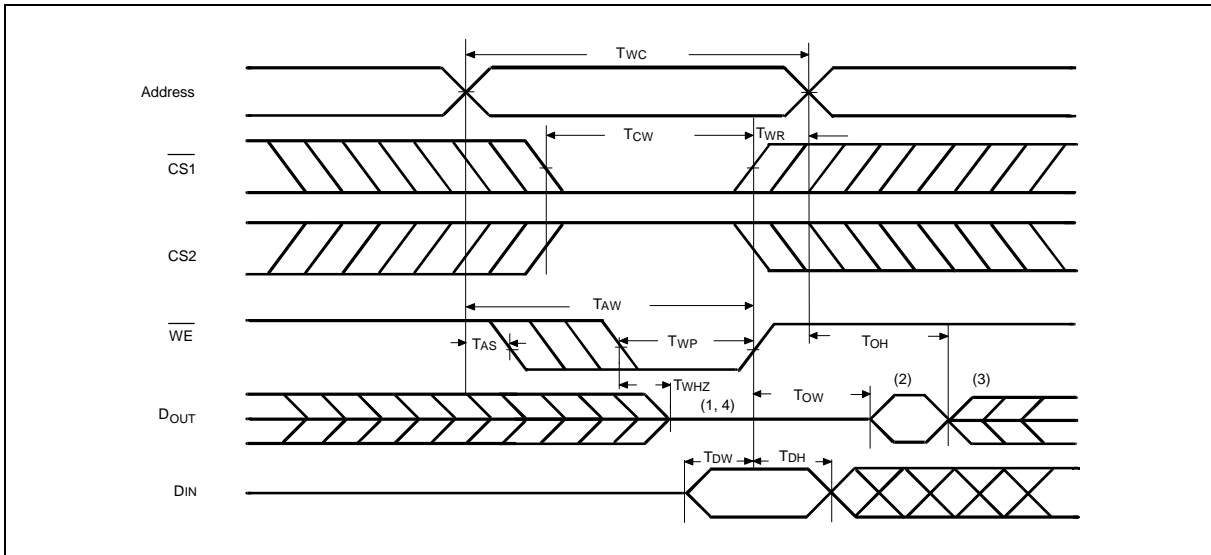

Notes:

1. During this period, I/O pins are in the output state, so input signals of opposite phase to the outputs should not be applied.
2. The data output from DOUT are the same as the data written to DIN during the write cycle.
3. DOUT provides the read data for the next address.
4. Transition is measured ± 500 mV from steady state with $C_L = 5$ pF. This parameter is guaranteed but not 100% tested.

DATA RETENTION CHARACTERISTICS

(TA (°C) = -20 to 85 for LE; -40 to 85 for LI)

PARAMETER	SYM.	TEST CONDITIONS	MIN.	TYP.	MAX.	UNIT
VDD for Data Retention	VDR	$\overline{CS1} \geq V_{DD} - 0.2V$ or $CS2 \leq 0.2V$	2.0	-	-	V
Data Retention Current	I _{DDDR}	$\overline{CS1} \geq V_{DD} - 0.2V$ or $CS2 \leq 0.2V, V_{DD} = 3V$	-	-	5	μA
Chip Deselect to Data Retention Time	T _{CDR}	See data retention waveform	0	-	-	nS
Operation Recovery Time	T _R		T _{RC} *	-	-	nS

* Read Cycle Time

DATA RETENTION WAVEFORM

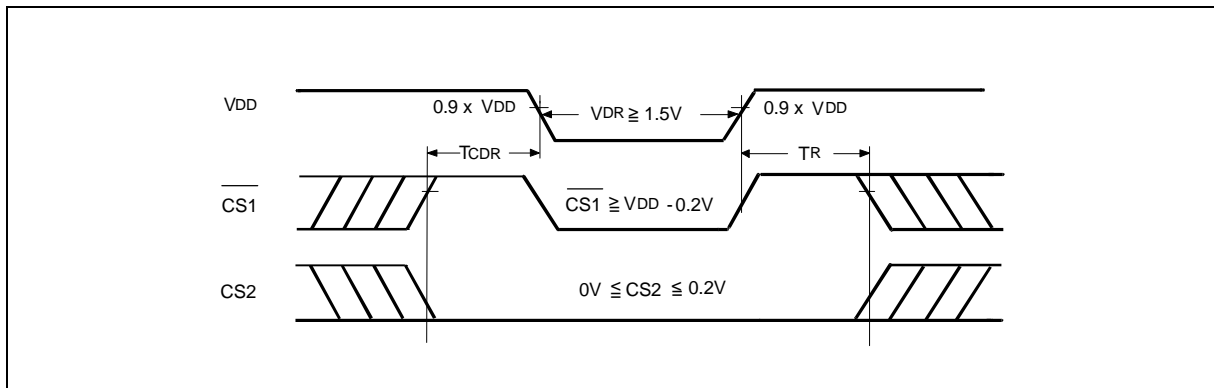



ORDERING INFORMATION

PART NO.	ACCESS TIME (nS)	OPERATING VOLTAGE (V)	OPERATING TEMPERATURE (°C)	PACKAGE
W24010-70LE	70/100	5V/3V	-20 to 85	600 mil DIP
W24010S-70LE	70/100	5V/3V	-20 to 85	450 mil SOP
W24010T-70LE	70/100	5V/3V	-20 to 85	Standard type one TSOP
W24010Q-70LE	70/100	5V/3V	-20 to 85	Small type one TSOP
W24010-70LI	70/100	5V/3V	-40 to 85	600 mil DIP
W24010S-70LI	70/100	5V/3V	-40 to 85	450 mil SOP
W24010T-70LI	70/100	5V/3V	-40 to 85	Standard type one TSOP
W24010Q-70LI	70/100	5V/3V	-40 to 85	Small type one TSOP

Notes:

1. Winbond reserves the right to make changes to its products without prior notice.
2. Purchasers are responsible for performing appropriate quality assurance testing on products intended for use in applications where personal injury might occur as a consequence of product failure.

PACKAGE DIMENSIONS

32-pin P-DIP

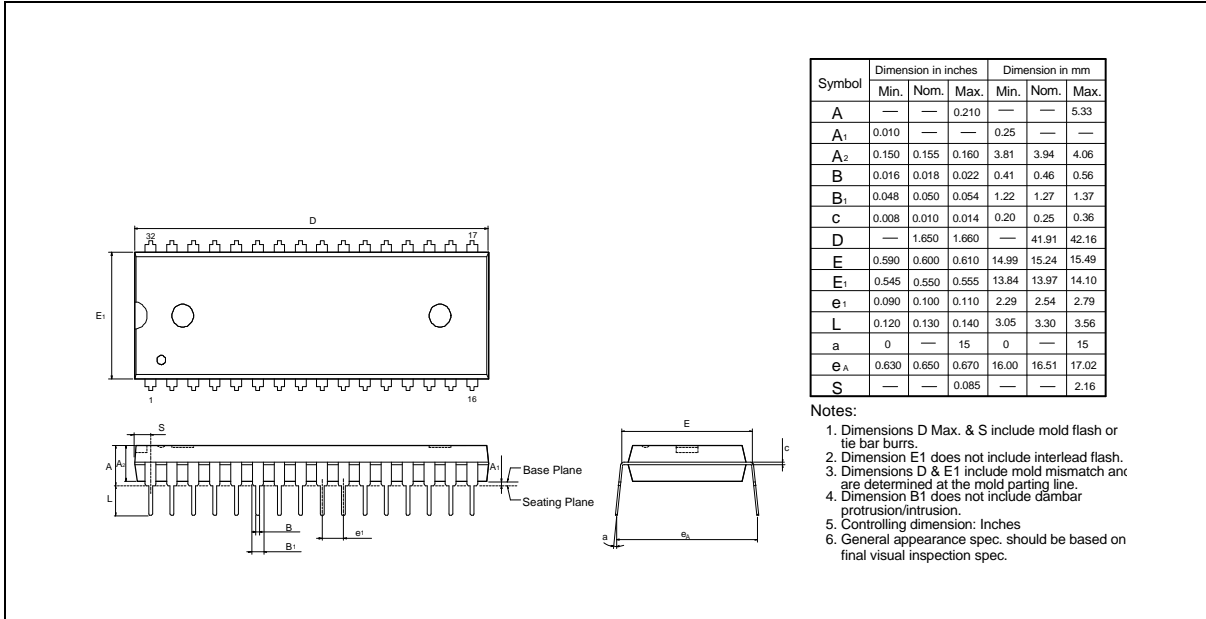

32-pin SOP Wide Body

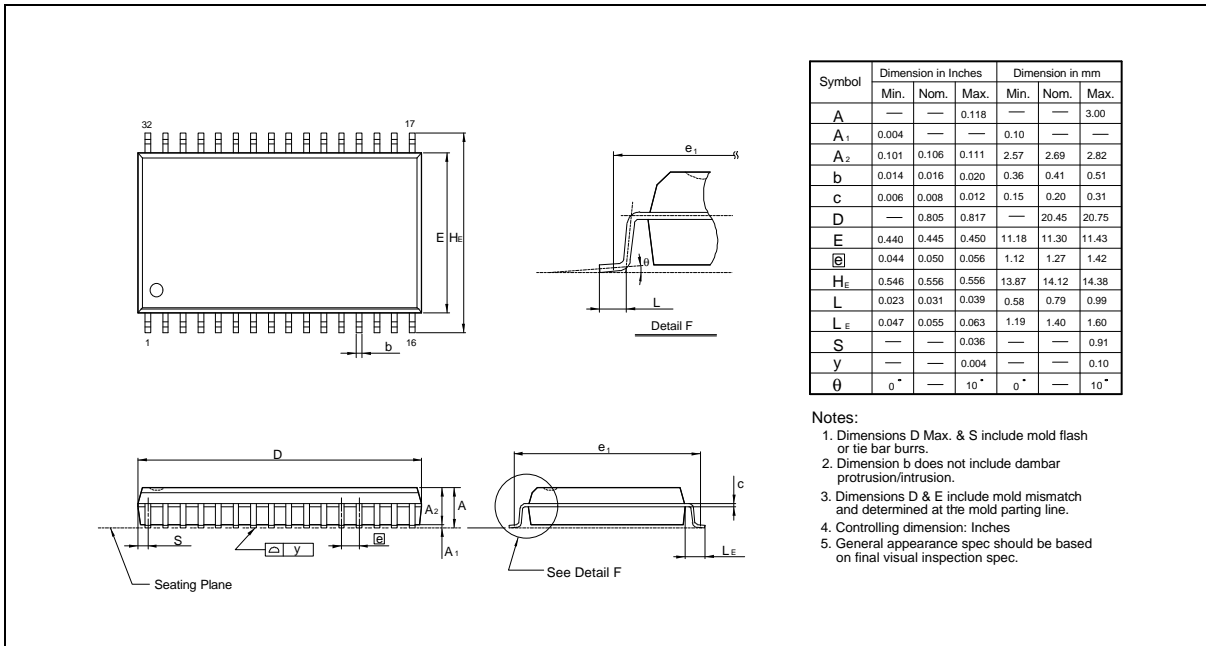

Package Dimensions, continued

32-pin Standard Type One TSOP

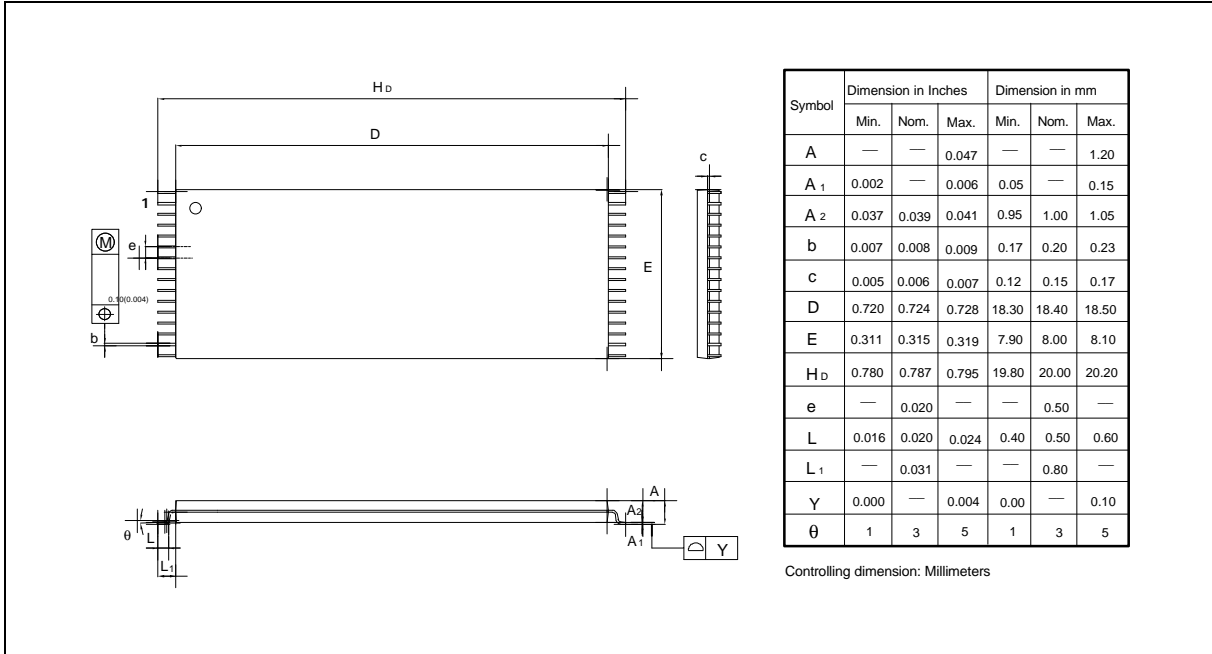

32-pin Small Type One TSOP

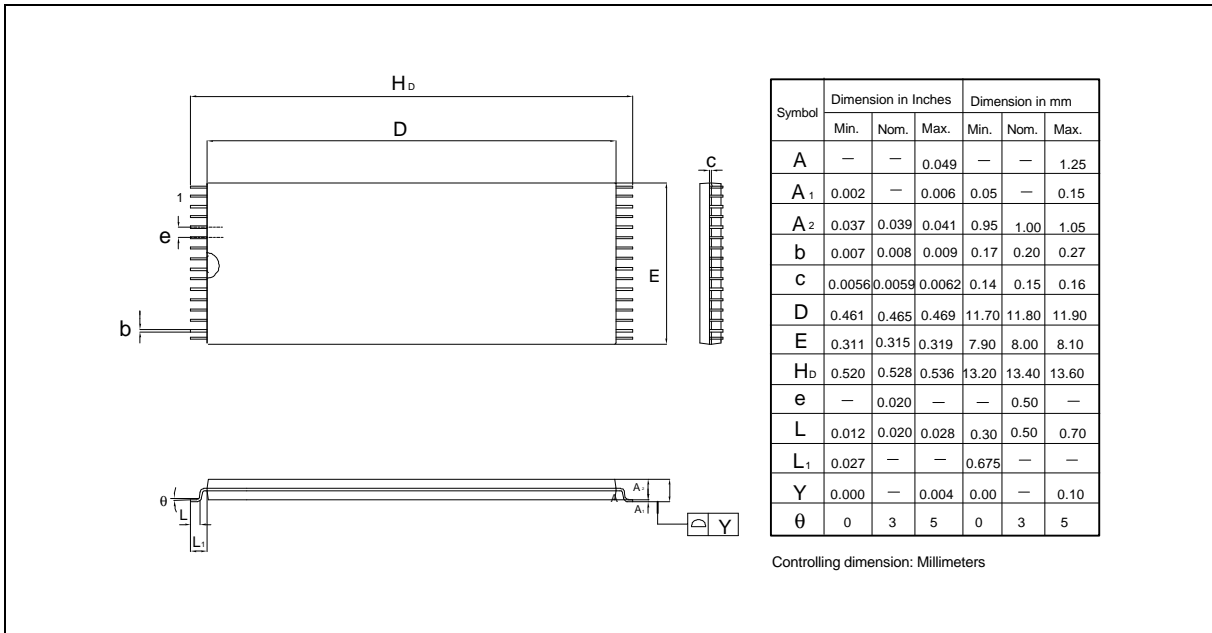



VERSION HISTORY

VERSION	DATE	PAGE	DESCRIPTION
A1	Jun. 1996	-	Initial Issued
A2	Dec. 1996	-	NA
A3	Feb. 1998	1, 2, 4, 7, 8	Delete operating temperature (SL = 0 to 70 °C)
A4	Apr. 1998	3	Add standby power supply current (I _{SB1}) typical parameter when operation temperature TA = 25° C
A5	Jun. 1998	2, 3	Correct Operating Characteristics: add $\overline{CS1}$, CS2 test conditions
		7	Correct data retention characteristics: add $\overline{CS1}$, CS2 test conditions
A6	Nov. 1998	1, 8, 10, 11	Deduct reverse type one TSOP package



Headquarters

No. 4, Creation Rd. III,
Science-Based Industrial Park,
Hsinchu, Taiwan
TEL: 886-3-5770066
FAX: 886-3-5796096
<http://www.winbond.com.tw/>
Voice & Fax-on-demand: 886-2-27197006

Taipei Office

11F, No. 115, Sec. 3, Min-Sheng East Rd.,
Taipei, Taiwan
TEL: 886-2-27190505
FAX: 886-2-27197502

Winbond Electronics (H.K.) Ltd.

Rm. 803, World Trade Square, Tower II,
123 Hoi Bun Rd., Kwun Tong,
Kowloon, Hong Kong
TEL: 852-27513100
FAX: 852-27552064

Winbond Electronics North America Corp.

Winbond Memory Lab.
Winbond Microelectronics Corp.
Winbond Systems Lab.
2727 N. First Street, San Jose,
CA 95134, U.S.A.
TEL: 408-9436666
FAX: 408-5441798

Note: All data and specifications are subject to change without notice.

Publication Release Date: November 1998