

# ST - 325

The ST-325 is a high-sensitivity NPN silicon phototransistor mounted in a red low profile side-viewing package. This phototransistor is both ultra-compact and easy to mount.

### FEATURES

- Side-viewing plastic package
- Ultra-Compact / Low-profile package

### APPLICATIONS

- Photointerrupters
- Tape-end sensors
- Optical switches

### DIMENSIONS

(Unit : mm)

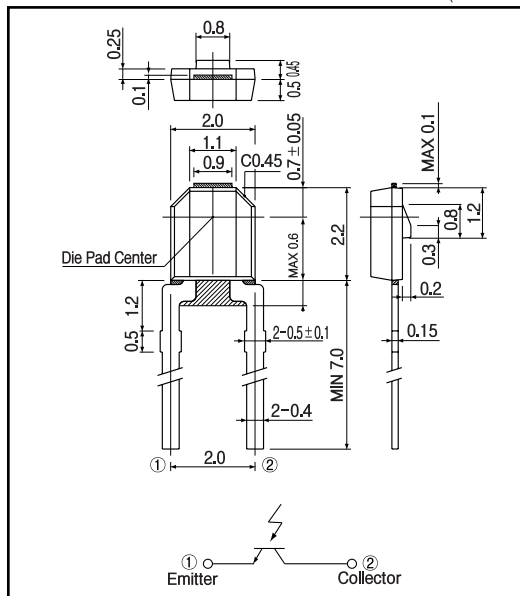

### MAXIMUM RATINGS

(Ta=25 )

Item	Symbol	Rating	Unit
C - E voltage	$V_{CE0}$	30	V
E - C voltage	$V_{ECO}$	5	V
Collector current	$I_C$	20	mA
Collector power dissipation	$P_C$	75	mW
Operating temp.	$T_{opr.}$	- 25 ~ + 85	
Storage Temp.	$T_{stg.}$	- 30 ~ + 85	
Soldering temp. *1	$T_{sol.}$	260	

\*1.For MAX.5 seconds at the position of 2 mm from the package

### ELECTRO-OPTICAL CHARACTERISTICS

(Ta=25 )

Item	Symbol	Conditions	Min.	Typ.	Max.	Unit.
Collector dark current	$I_{CEO}$	$V_{CE0} = 10V$			100	nA
Light current	$I_L$	$V_{CE} = 5V, E = 1000lx^{-2}$	0.4			mA
C - E saturation voltage	$V_{CE(sat)}$	$I_C = 0.5mA, E = 2000lx^{-2}$		0.2	0.4	V
Switching speeds	Rise time	$V_{CC} = 10V, I_C = 1mA, R_L = 100$		3.2		$\mu sec.$
	Fall time			4.8		
Spectral sensitivity				500 ~ 1,050		nm
Peak wavelength	$\rho$			880		nm
Half angle				$\pm 60$		deg.

\*2. Color temp. = 2856K standard Tungsten lamp

Photo transistors

ST - 325

**Collector current Vs. Collector - Emitter voltage**

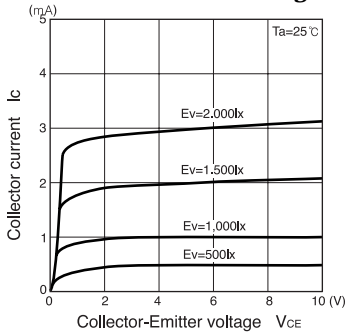

**Collector current Vs. Illuminance**

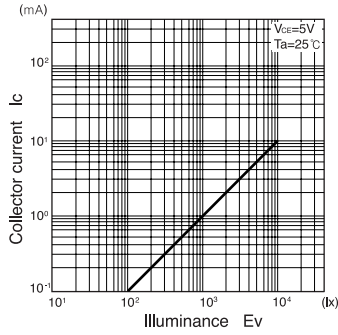

**Dark current Vs. Ambient temperature**

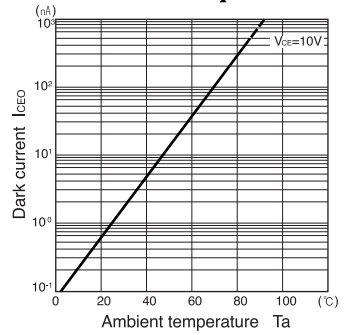

**Relative sensitivity Vs. Wavelength**

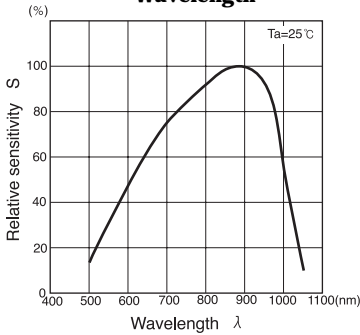

**Switching time vs. Load resistance**

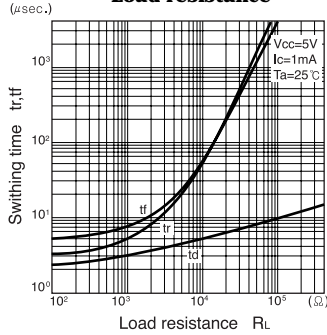

**Radiant Pattern**

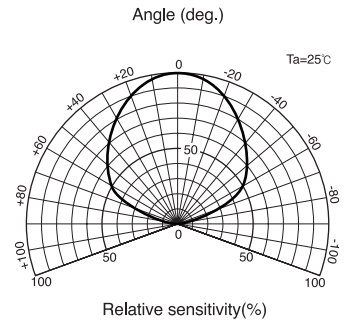

**Collector power dissipation Vs. Ambient temperature**

