

## MOTOR DRIVER FOR VTR

The KA8301 is a monolithic integrated circuit designed to perform bi-directional DC motor driving, braking and speed control for VCRs. The speed control can be achieved by adjusting the external voltage of the motor speed control pin.

## FEATURES

- Stable braking characteristics by built-in braking function.
- Built-in element to absorb dash current derived from changing motor direction and braking motor driving.
- Built-in external motor speed control pin.
- Stable driving direction change.
- CMOS logic level compatible input level.

## APPLICATION

- VCR
- CDP
- TOY

## BLOCK DIAGRAM

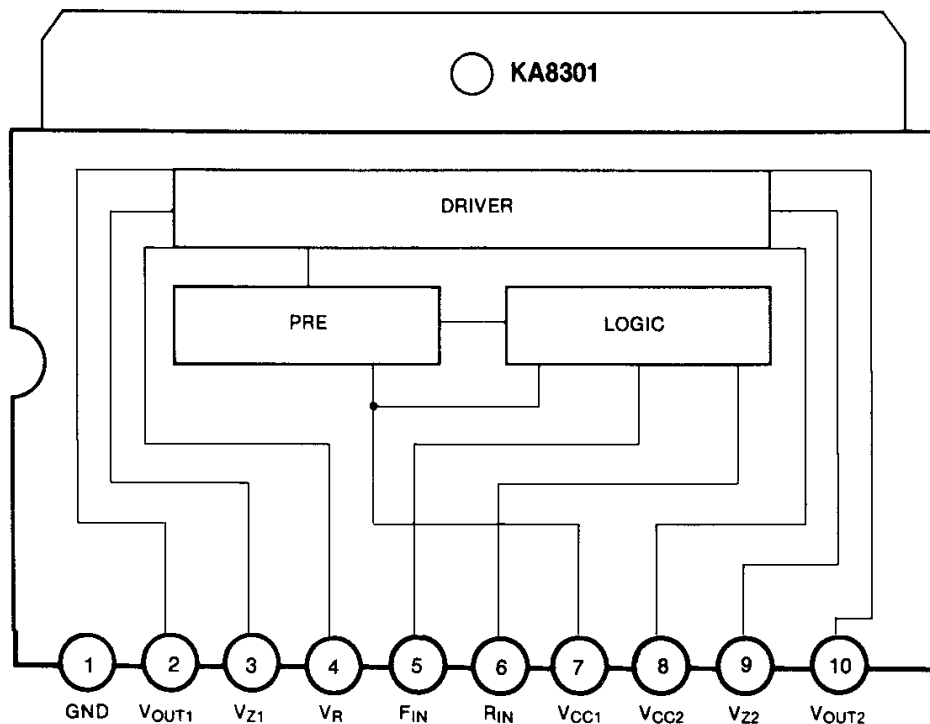
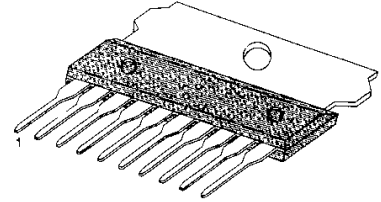

Fig. 1

10 SIP H/S



## ORDERING INFORMATION

Device	Package	Operating Temperature
KA8301	10 SIP H/S	- 25 ~ + 75°C

**ABSOLUTE MAXIMUM RATINGS (Ta = 25°C)**

Characteristics	Symbol	Value	Unit
Supply Voltage	$V_{CC}$	18	V
Allowable Power Dissipation	$P_D$	2.2	W
Operating Temperature	$T_{OPR}$	-25 ~ +75	°C
Storage Temperature	$T_{STG}$	-55 ~ +125	°C
Output Current	$I_{OUT}$	1.6*	A
Input Voltage	$V_{IN}$	-0.3 ~ $V_{CC}$	V

\* Duty 1/100, pulse width 500 $\mu$ s**RECOMMENDED OPERATING CONDITIONS (Ta = 25°C)**

Characteristics	Symbol	Min	Typ	Max	Unit
Supply Voltage	$V_{CC}$	8	12	16	V

**ELECTRICAL CHARACTERISTICS (V<sub>CC</sub> = 12V, Ta = 25°C)**

Characteristics	Symbol	Min	Typ	Max	Unit	Condition
Quiescent Current	$I_{CCQ}$	3	5.5	10	mA	Pin 5, 6: GND, $R_L = \infty$
Minimum Input on Current 1	$I_{IN1}$	—	10	50	$\mu$ A	$R_L = \infty$ , Pin 5: $I_{IN1}$ , Pin 6: L
Minimum Input on Current 2	$I_{IN2}$	—	10	50	$\mu$ A	$R_L = \infty$ , Pin 5: L, Pin 6: $I_{IN2}$
Input Threshold Voltage 1	$V_{INTH1}$	0.7	1.3	2.0	V	$R_L = \infty$ , Pin 5: $V_{INTH1}$ , Pin 6: L
Input Threshold Voltage 2	$V_{INTH2}$	0.7	1.3	2.0	V	$R_L = \infty$ , Pin 5: L, Pin 6: $V_{INTH2}$
Output Leakage Current 1	$I_{OL1}$	—	—	1	mA	$R_L = \infty$ , Pin 5, 6: GND
Output Leakage Current 2	$I_{OL2}$	—	—	1	mA	$R_L = \infty$ , Pin 5, 6: GND
Zener Current 1	$I_{Z1}$	—	0.85	1.5	mA	Pin 5: H, Pin 6: L, $R_L = \infty$
Zener Current 2	$I_{Z2}$	—	0.85	1.5	mA	Pin 5: L, Pin 6: H, $R_L = \infty$
Output Voltage 1	$V_{O1}$	6.6	7.2		V	Pin 5: H, Pin 6: L, $R_L = 60\text{ohm}$
Output Voltage 2	$V_{O2}$	6.6	7.1		V	Pin 5: L, Pin 6: H, $R_L = 60\text{ohm}$
Saturation Voltage Pin 10-1	$V_{CE10-1}$	—	0.83	1.5	V	$I_{SINK} = 100\text{mA}$ Pin 5: H, Pin 6: L, $R_L, R_C = \infty$
Saturation Voltage Pin 2-1	$V_{CE2-1}$	—	0.83	1.5	V	$I_{SINK} = 100\text{mA}$ Pin 5: L, Pin 6: H, $R_L, R_C = \infty$
Saturation Voltage Pin 8-2	$V_{CE8-2}$	—	0.83	1.5	V	$I_{SOURCE} = 100\text{mA}$ Pin 5: H, Pin 6: L, $R_L, R_C = \infty$
Saturation Voltage Pin 8-10	$V_{CE8-10}$	—	0.83	1.5	V	$I_{SOURCE} = 100\text{mA}$ Pin 5: L, Pin 6: H, $R_L, R_C = \infty$

## TEST CIRCUIT

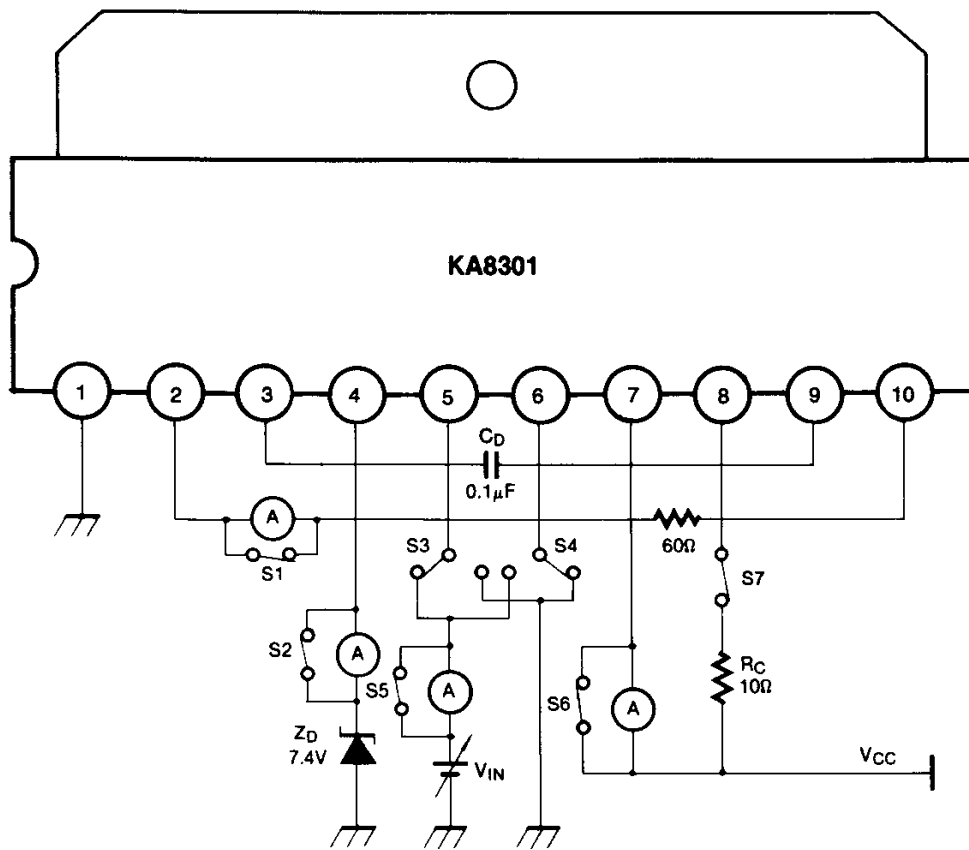

Fig. 2

## LOGIC TRUTH TABLE

$F_{IN}$ (Pin 5)	$R_{IN}$ (Pin 6)	$V_{O1}$ (Pin 2)	$V_{O2}$ (Pin 10)	Note
L	L	L	L	Braking
L	H	L	H	Reverse
H	L	H	L	Forward
H	H	L	L	Braking

\* Input Level 'H' > 2.0V

Input Level 'L' < 0.7V

## APPLICATION INFORMATION

### – FORWARD & REVERSE CONTROL LOGIC

If  $F_{IN}$  (5 pin) &  $R_{IN}$  (6 pin) = 'L', load current ( $I_L$ ) flows from  $V_{OUT1}$  (2 pin) to  $V_{OUT2}$  (10 pin).

If  $F_{IN}$  = 'L' &  $R_{IN}$  = 'H', load current ( $I_L$ ) flows from  $V_{OUT2}$  to  $V_{OUT1}$ .

### – FORCED STOP LOGIC

If  $F_{IN}$  &  $R_{IN}$  = 'H' or 'L'. The device stops supplying power to motor while absorbing counter electromotive force from the motor as a brake.

### – RUSH CURRENT ABSORBING CIRCUIT

If a high voltage generated during reversing operation is applied across  $V_{OUT1}$  &  $V_{OUT2}$ , an internal comparator activates the rush current absorbing circuit.

### – DRIVING STAGE

In the forward mode, the driving stage supplies a load current to the motor from 2 pin to 10 pin. In the reverse mode. It supplies the current from 10 pin to 2 pin.

The output voltage  $V_{OUT}$  applied to the motor is given by the following method:

$V_{OUT(V)} = V_{ZD} - V_{CE(SAT)}$   $V_{ZD}$ ; Zener Voltage applied to 4 pin.

If 4 pin is left open, the output voltage is given by the following method:

$V_{OUT(V)} = V_{CCI} - V_{CE(SAT PNP)} - 2V_F - V_{CE(SAT)}$

**POWER REDUCTION CURVE**

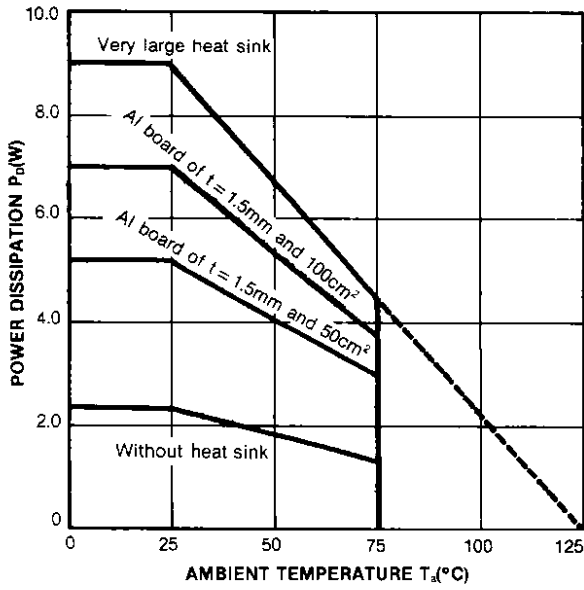

**QUIESCENT CURRENT VS. SUPPLY VOLTAGE**

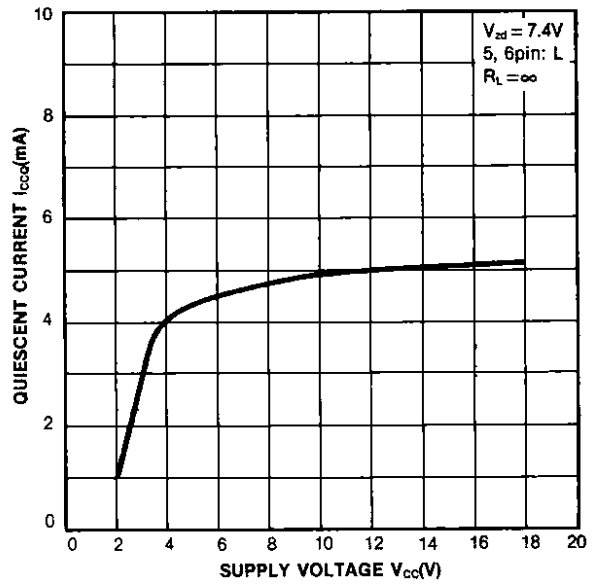

**MAXIMUM OUTPUT VOLTAGE VS. SUPPLY VOLTAGE**

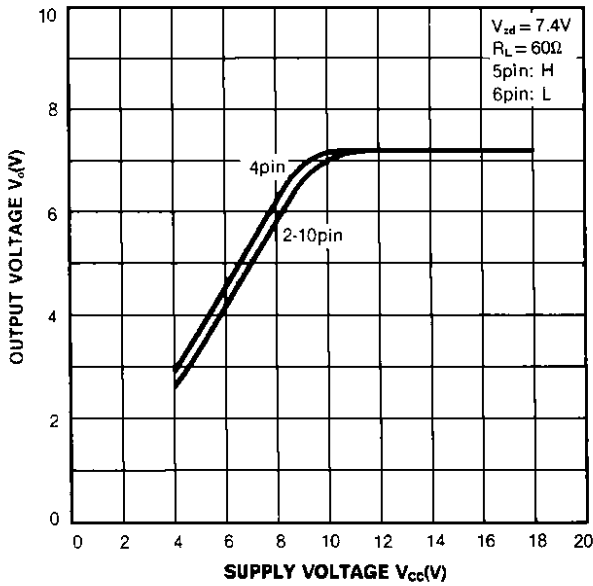

**MAXIMUM OUTPUT VOLTAGE VS. SUPPLY VOLTAGE**

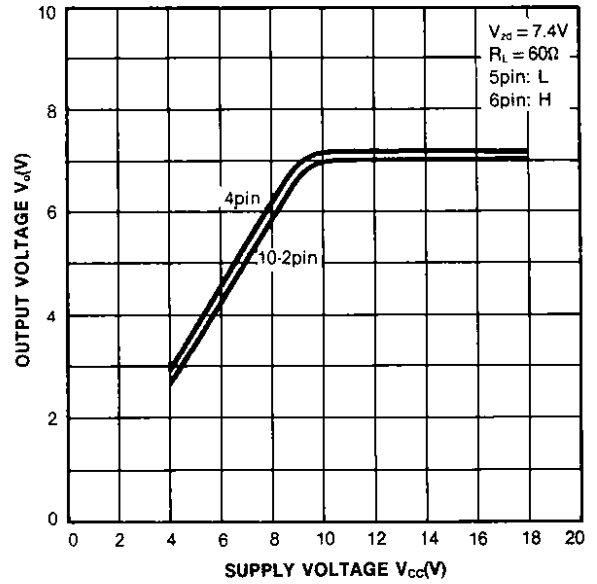

**QUIESCENT CURRENT VS. AMBIENT TEMPERATURE**

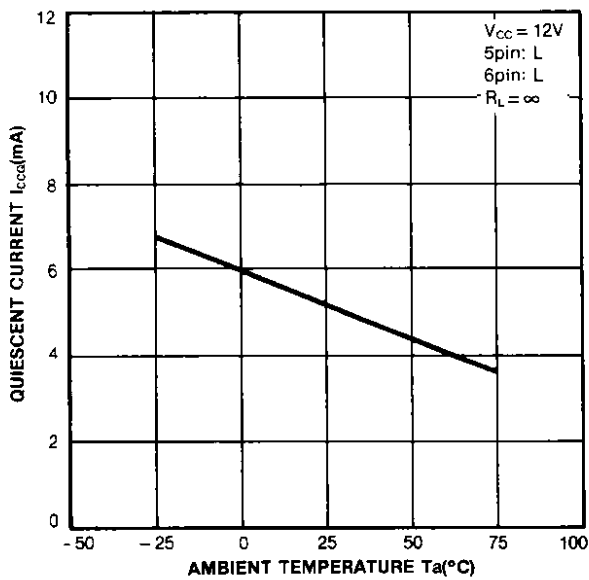

**OUTPUT VOLTAGE VS. AMBIENT TEMPERATURE**

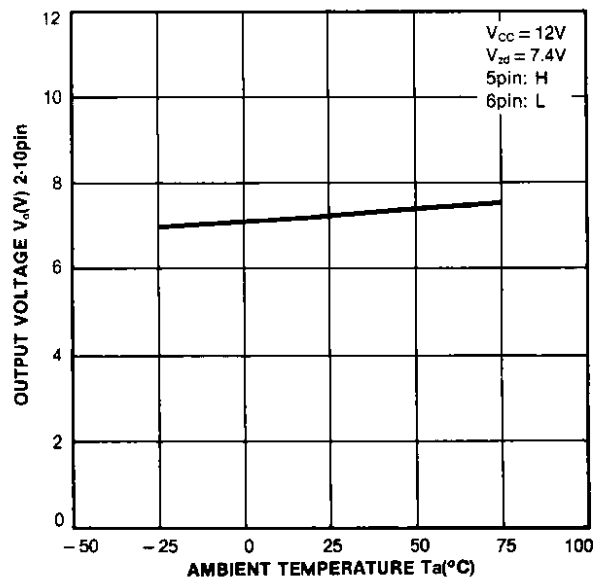

**OUTPUT VOLTAGE VS. AMBIENT TEMPERATURE**

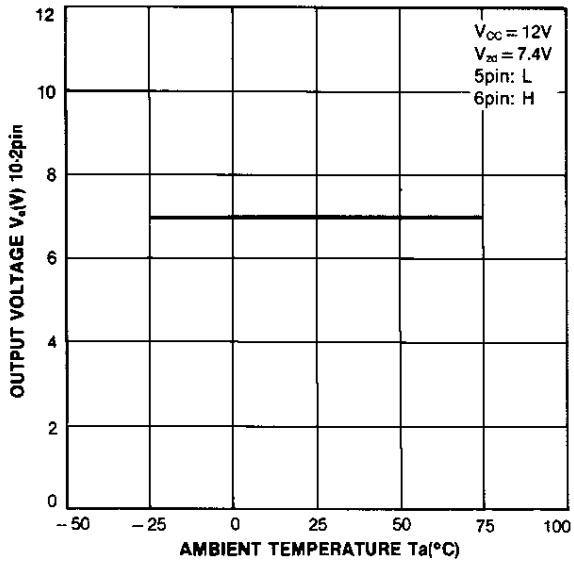

**OUTPUT SATURATION VOLTAGE VS. SINK CURRENT**

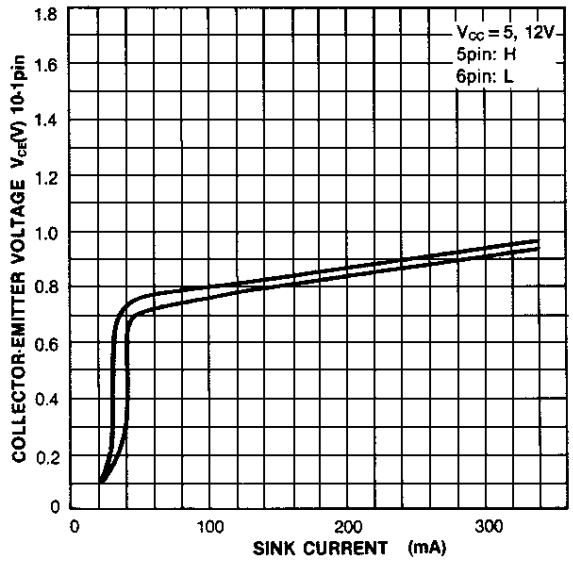

**OUTPUT SATURATION VOLTAGE VS. SINK CURRENT**

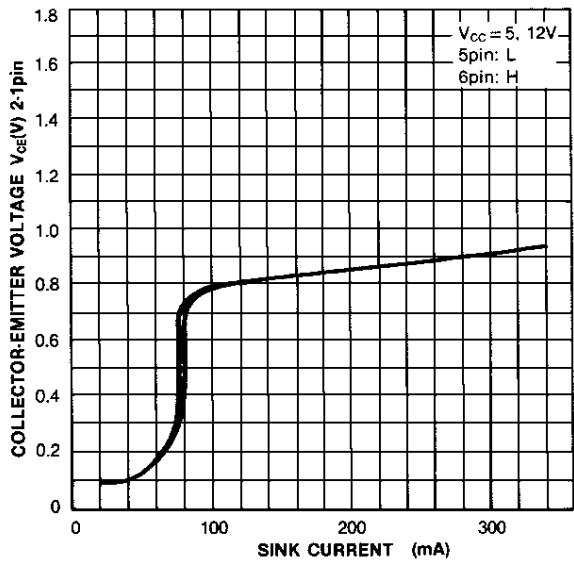

**OUTPUT SATURATION VOLTAGE VS. SOURCE CURRENT**

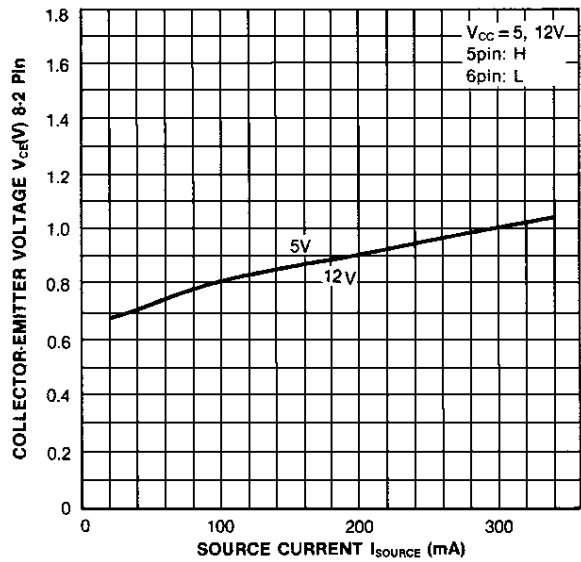

**OUTPUT SATURATION VOLTAGE VS. SOURCE CURRENT**

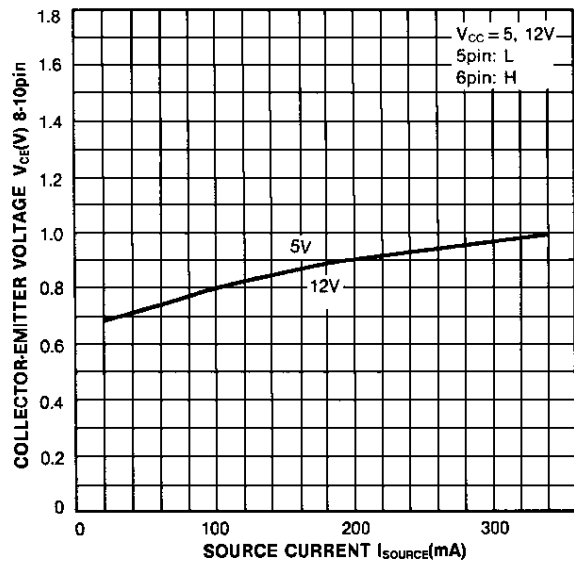

**OUTPUT VOLTAGE VS. REFERENCE VOLTAGE**

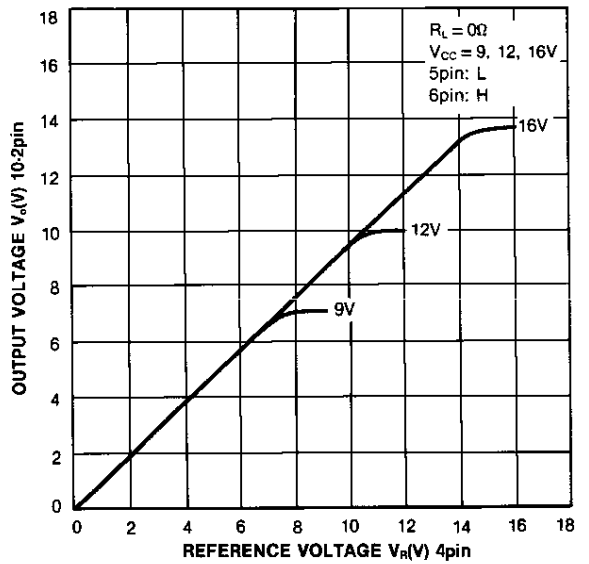

**OUTPUT VOLTAGE VS. REFERENCE VOLTAGE**

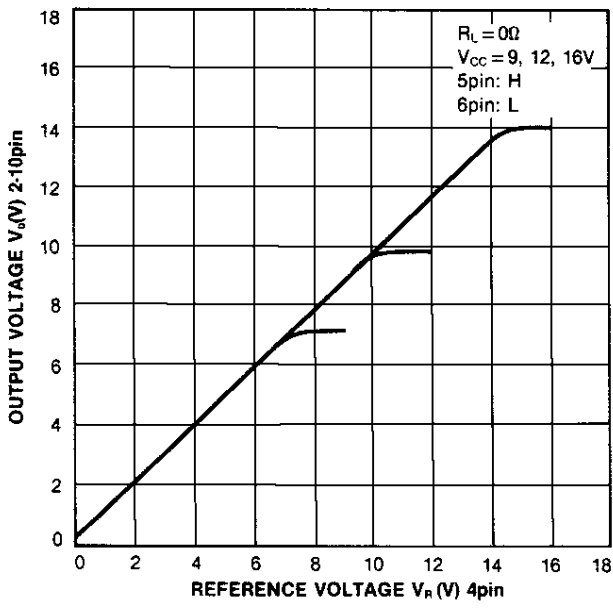

**ZENER CURRENT VS. OUTPUT CURRENT**

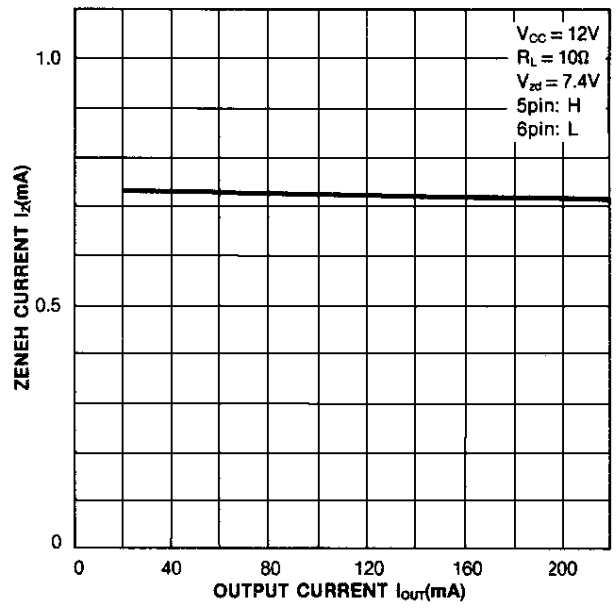

**OUTPUT VOLTAGE VS. OUTPUT CURRENT**

