



ZHX1810

***Slim Series SIR
Transceiver***

Product Specification

PS009313-1202



This publication is subject to replacement by a later edition. To determine whether a later edition exists, or to request copies of publications, contact:

ZiLOG Worldwide Headquarters

532 Race Street
San Jose, CA 95126-3432
Telephone: 408.558.8500
Fax: 408.558.8300
www.ZiLOG.com

ZiLOG is a registered trademark of ZiLOG Inc. in the United States and in other countries. All other products and/or service names mentioned herein may be trademarks of the companies with which they are associated.

Document Disclaimer

©2002 by ZiLOG, Inc. All rights reserved. Information in this publication concerning the devices, applications, or technology described is intended to suggest possible uses and may be superseded. ZiLOG, INC. DOES NOT ASSUME LIABILITY FOR OR PROVIDE A REPRESENTATION OF ACCURACY OF THE INFORMATION, DEVICES, OR TECHNOLOGY DESCRIBED IN THIS DOCUMENT. ZiLOG ALSO DOES NOT ASSUME LIABILITY FOR INTELLECTUAL PROPERTY INFRINGEMENT RELATED IN ANY MANNER TO USE OF INFORMATION, DEVICES, OR TECHNOLOGY DESCRIBED HEREIN OR OTHERWISE. Devices sold by ZiLOG, Inc. are covered by warranty and limitation of liability provisions appearing in the ZiLOG, Inc. Terms and Conditions of Sale. ZiLOG, Inc. makes no warranty of merchantability or fitness for any purpose. Except with the express written approval of ZiLOG, use of information, devices, or technology as critical components of life support systems is not authorized. No licenses are conveyed, implicitly or otherwise, by this document under any intellectual property rights.



Table of Contents

Description	1
Features	1
Block Diagram	2
Pin Descriptions	2
LEDA LED Driver Anode	3
TXD Transmit Data	3
RXD/Receive Data	3
SD Shutdown	3
VCC Positive Supply	3
GND Ground	3
TAB	3
Recommended Application Circuits	4
Electrical and Timing Specifications	5
Mechanical Drawings	8
Soldering and Cleaning Recommendations	10
Reflow Soldering	10
Manual Soldering	10
Cleaning	11
Packing, Storage, and Baking Recommendations	11
Storage	11
Baking	11
Moisture-Proof Packing	12
Taping Specifications	13
Ordering Information	15
Customer Feedback Form	16
Customer Information	16
Product Information	16
Return Information	16
Problem Description or Suggestion	16



List of Figures

Figure 1. Slim SIR Transceiver Block Diagram	2
Figure 2. Application Block Diagrams	4
Figure 3. I_F - I_e Characteristics (0°)	6
Figure 4. I_F -LEDA Characteristics (0°)	7
Figure 5. Directive Characteristics (Emitting)	7
Figure 6. Directive Characteristics (Receiving)	7
Figure 7. ZHX1810 Mechanical Drawing	8
Figure 8. Alternative ZHX1810 Mechanical Drawing	9
Figure 9. Temperature Profile at the Top Surface of ZHX1810	10
Figure 10. ZHX1810 Packaging	12
Figure 11. ZHX1810 Reel Dimensions (Unit: mm)	13
Figure 12. ZHX1810 Tape Dimensions and Configuration (Unit: mm)	14

List of Tables

Table 1. Pin Out for the ZHX1810 Transceiver	2
Table 2. Absolute Maximum Ratings	5
Table 3. Recommended Operating Conditions	5
Table 4. Electrical Characteristics	5

Description

The ZILOG ZHX1810 is a low-profile version of ZiLOG's popular ZHX1010 1-meter transceiver. The transceiver is mechanically enhanced for ultra compact, power-conscious portable products, such as mobile phones, portable printers, handheld computers, and personal data assistants (PDAs). Designed to operate using the IrDA-Data mode, the transceiver combines an infrared emitting diode (IRED) emitter, a PIN photodiode detector, a digital AC coupled LED driver, and a receiver/decoder in a single package.

The ZILOG ZHX1810 provides an efficient implementation of the SIR standard in a small-outline footprint format. Application circuit space is also minimized, as only three components are required.

ZHX1810 also features an independently controlled shutdown that minimizes current draw to a maximum of 1 μ A.

Features

- Compliant to IrDA Data Specification SIR
- Wide power supply voltage range, 2.4 to 5.5 V
- Minimum link distance, 1 M
- Low-power, listening current, 90 μ A (typical) at 3.0 V
- Slim form factor (9.1 mm long x 3.8 mm wide x 2.73 mm high)
- Only two external components required
- Extended operating temperature range (-30 °C to $+85$ °C)
- Meets IEC 825-1 Class 1 Eye Safety Specifications

Block Diagram

Figure 1 is the block diagram for the Slim SIR transceiver.

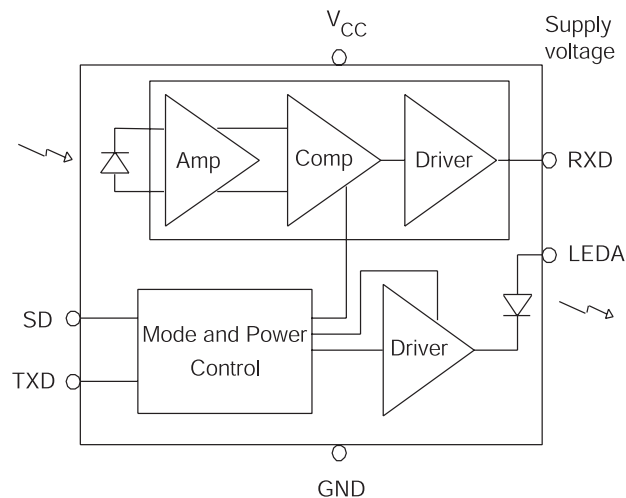

Figure 1. Slim SIR Transceiver Block Diagram

Pin Descriptions

The ZHX1810 transceiver uses the pins listed in Table 1. The pins are described in this section.

Table 1. Pin Out for the ZHX1810 Transceiver

Pin	Name	Function	I/O
1	LEDA	IRED anode	—
2	TXD	Transmitter input	I
3	RXD	Receiver output	O
4	SD	Enables shutdown mode	I
5	V _{CC}	Supply voltage	—
6	GND	Ground	—
—	TAB	Shield ground	—

LEDA LED Driver Anode

(Power)

This output is connected to the LED anode. Current to the LED is sourced through an external resistor.

TXD Transmit Data

(Input, active high)

This CMOS input is used to transmit serial data. This input has an internal pull-down resistor that is disabled (open-circuited) during shutdown.

RXD/Receive Data

(Output, active low)

This output indicates received serial data. It is a tri-state, slew rate controlled CMOS output (tri-stated during shutdown) driver capable of driving a standard CMOS load. No external resistor is required.

SD Shutdown

(Input, active high)

This input is used to place the integrated circuit into shutdown mode. Module shutdown current is influenced by the choice of capacitor used from V_{CC} to ground.

V_{CC} Positive Supply

(Power)

Connect to positive power supply (2.4–5.5 V). Filter with a 0.33- μ F ceramic bypass capacitor and terminating resistor as close as possible to the V_{CC} pin.

GND Ground

(Power)

Connect to ground of the power supply. A solid ground plane is recommended for proper operation.

TAB

(Shield)

The Shield tab must be soldered to the ground plane.

Recommended Application Circuits

Figure 2 shows application block diagrams for the ZHX1810 transceiver.

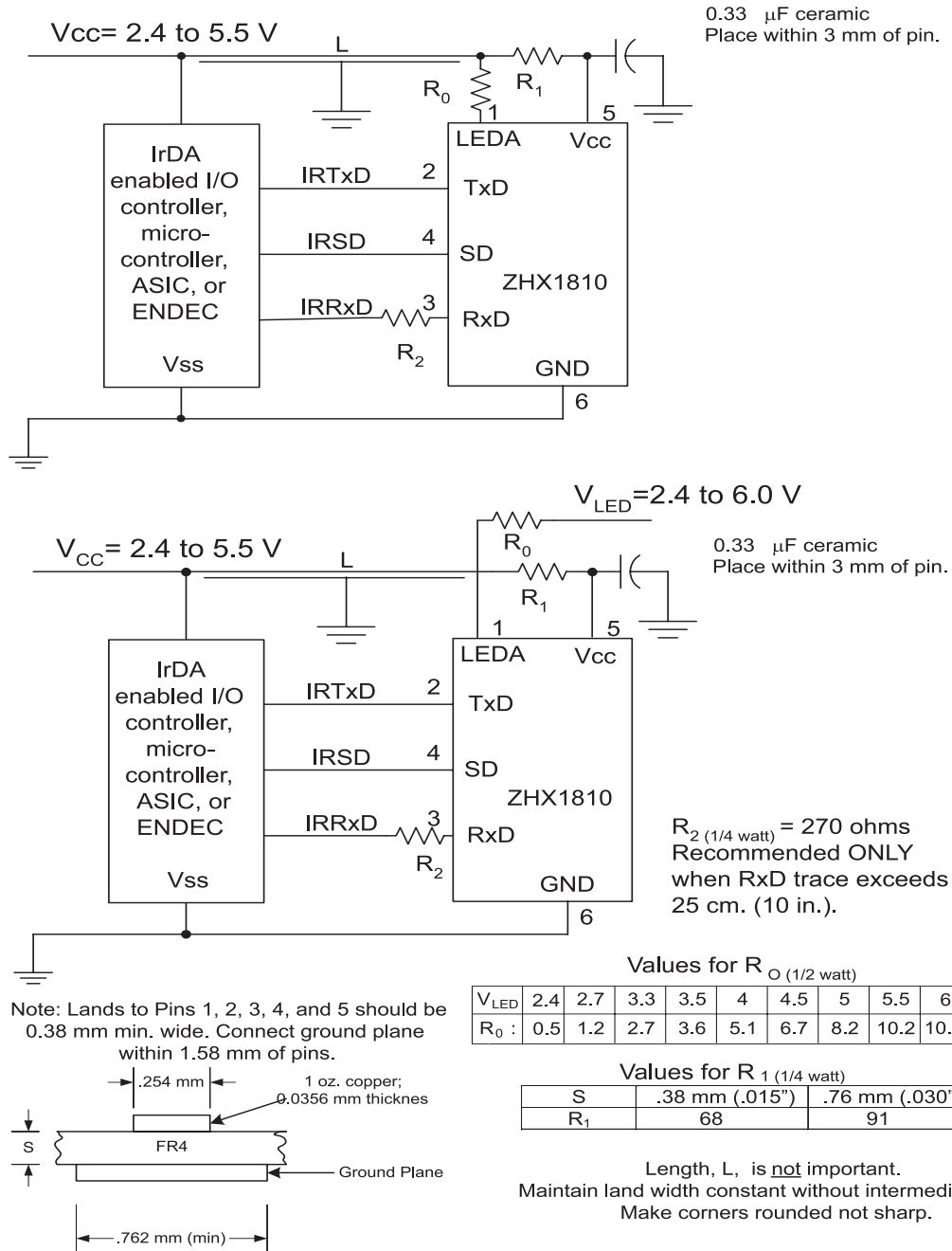

Figure 2. Application Block Diagrams

Electrical and Timing Specifications

Table 2 through Table 4 present the electrical and timing specifications for the ZHX1810 transceiver.

Table 2. Absolute Maximum Ratings

Parameter	Symbol	Minimum	Maximum	Unit	Comment
Supply Voltage	V_{CC}	-0.3	6.0	V	V_{CC} , GND
Input Voltage	V_{IN}	GND-0.3	$V_{CC}+0.3$	V	TXD, SD
Output (External) Voltage	V_{OUT}	GND-0.3	$V_{CC}+0.3$	V	RxD
LED Current	I_{LED}		700	mA	20% duty cycle, $T_a=25\text{ }^\circ\text{C}$, $t_{ON}\leq 90\text{ }\mu\text{S}$
Storage Temperature	T_{ST}	-40	100	$^\circ\text{C}$	
Solder Temperature	T_{SOL}		240	$^\circ\text{C}$	

Table 3. Recommended Operating Conditions

Parameter	Symbol	Minimum	Maximum	Unit
Supply Voltage	V_{CC}	2.4	5.5	V
LED Voltage	V_{LED}	2.4	6.0	V
Ambient Operating Temperature	T_{OP}	-30	85	$^\circ\text{C}$

Table 4. Electrical Characteristics

Parameter	Symbol	Condition	Min	Typical	Max	Unit	Remarks
High-Level Input Voltage	V_{IH}		$0.6 V_{CC}$		$V_{CC}+0.5$	V	TXD, SD
Low-Level Input Voltage	V_{IL}		-0.5		$0.2 V_{CC}$	V	TXD, SD
High-Level Output Voltage	V_{OH}		2.2			V	RxD
Low-Level Output Voltage	V_{OL}				0.4	V	RxD
Transmitter Current	I_{LED}			300		mA	
Listening Current	I_{CC}			90	150	μA	
Receive Current	I_{CC}			90	150	μA	

Unless otherwise noted: $V_{CC}=3.3\text{ V}$, GND= 0 V, $T_A= 25\text{ }^\circ\text{C}$

Table 4. Electrical Characteristics (Continued)

Parameter	Symbol	Condition	Min	Typical	Max	Unit	Remarks
Standby Current	I_{STB}				1	μA	SD= V_{CC} , TxD=0 V
Optical Rise/Fall Time	t_{Rr} , t_{Rf}			100		nS	
RxD Pulse Width	t_{PWA}	SIR=115.2 Kbps	1.1	1.6	3.9	μS	
Power Shutdown Time	T_{SD}				1	μS	
Startup Time	T_{STU}				200	μS	
Receiver Latency	T_L			100		μs	
Trans. Radiant Intensity	I_E	$I_{LED}=260$ mA	40		100	mW/sr	θ_h , $\theta_v \leq (\pm 15^\circ)$
Min. Threshold Irradiance	E_{emin}	$V_{CC}=3.3$ V		2	3	$\mu W/cm^2$	θ_h , $\theta_v \leq (\pm 15^\circ)$
Angle of Half Intensity	θ			20		$^\circ$	Hor. and Vert.
Light Pulse Rise, Fall Time	t_{Or} , t_{Of}			40		nS	
Optical Pulse Width	t_{OPW}			20		μS	TxD="H"
Optical Overshoot	t_{OPO}				3	%	
Peak Wavelength	λ_P			870		nm	

Unless otherwise noted: $V_{CC}=3.3$ V, GND= 0 V, $T_A= 25$ °C

Figure 3 through Figure 6 show various electrical characteristics.

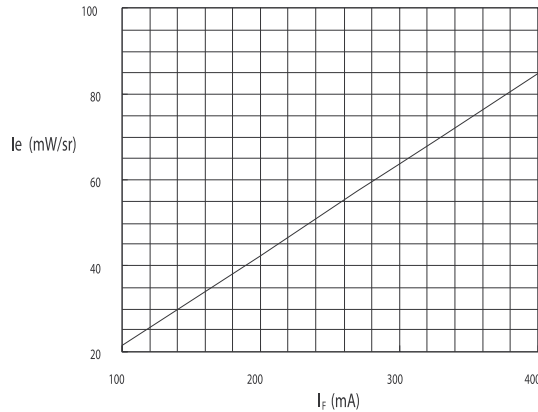

Figure 3. I_F - I_E Characteristics (0°)

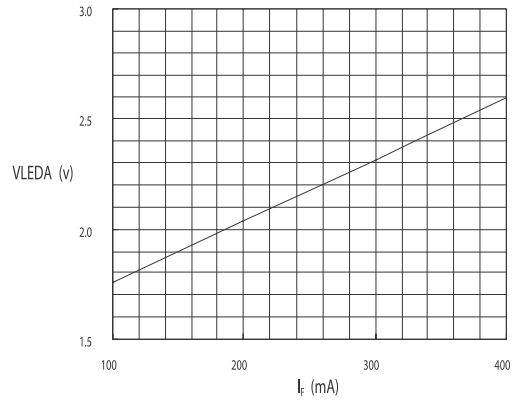

Figure 4. I_f -LEDA Characteristics (0°)

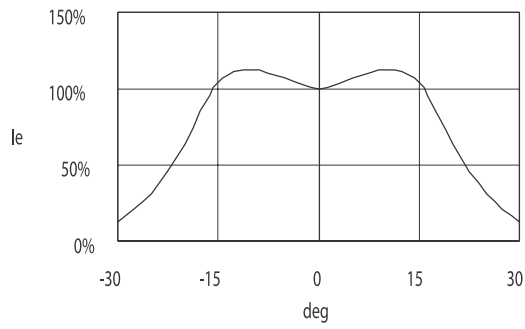

Figure 5. Directive Characteristics (Emitting)

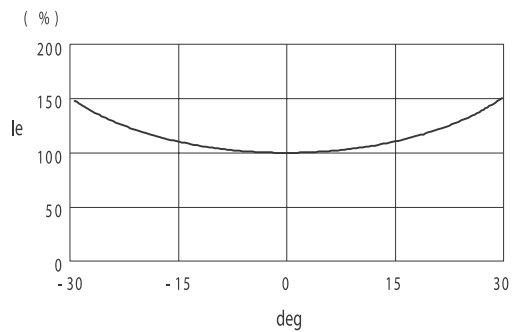

Figure 6. Directive Characteristics (Receiving)

Mechanical Drawings

In order to achieve the lowest possible lead times, ZiLOG maintains two assembly facilities. The mechanical drawings for these transceivers are shown in Figure 7 and Figure 8. These devices, which show minor mechanical differences, are functionally equivalent in every way and meet all ZiLOG and IrDA standards and specifications. Although reels are never mixed, ZiLOG reserves the right to ship from either facility in order to meet delivery requirements.

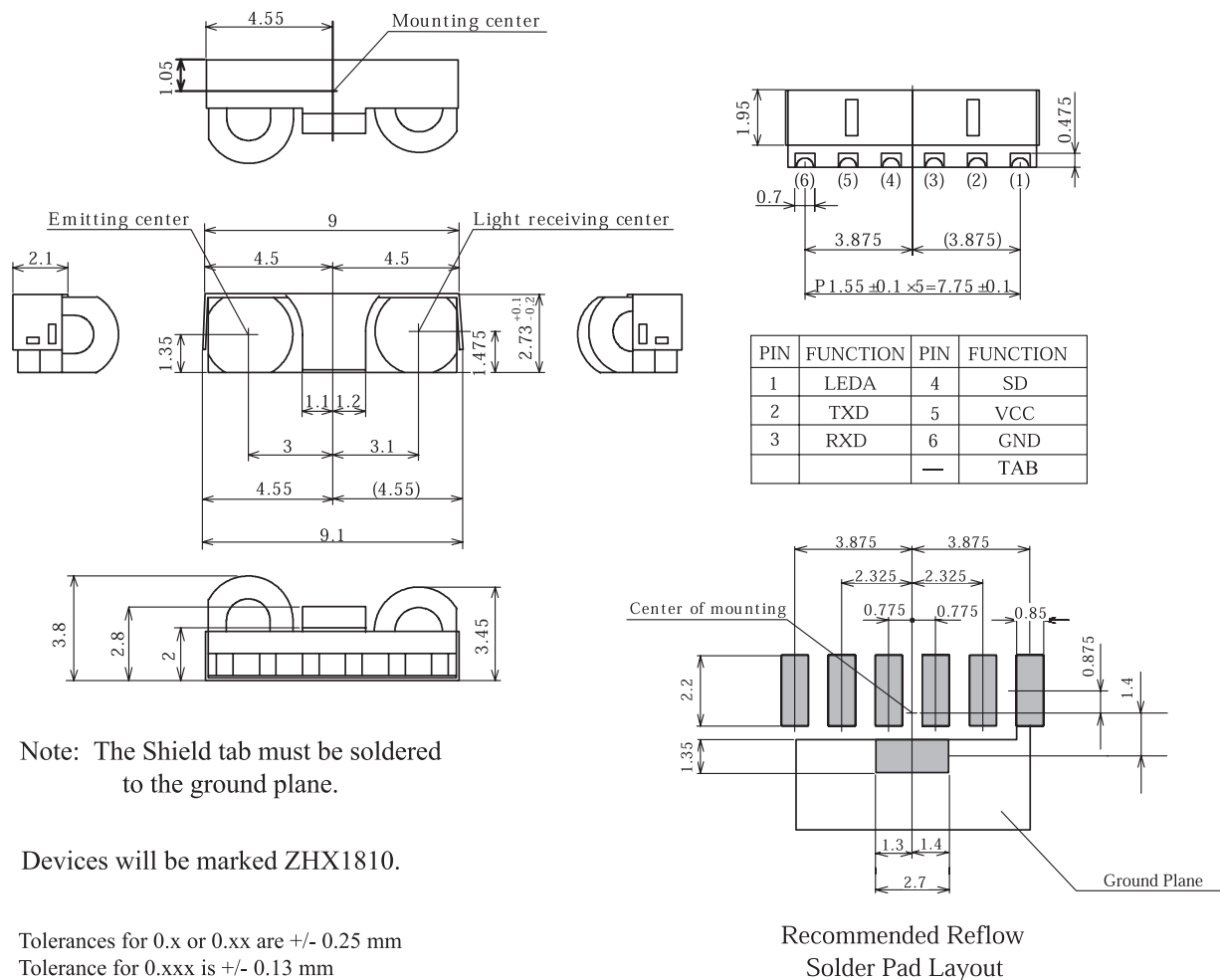

Figure 7. ZHX1810 Mechanical Drawing

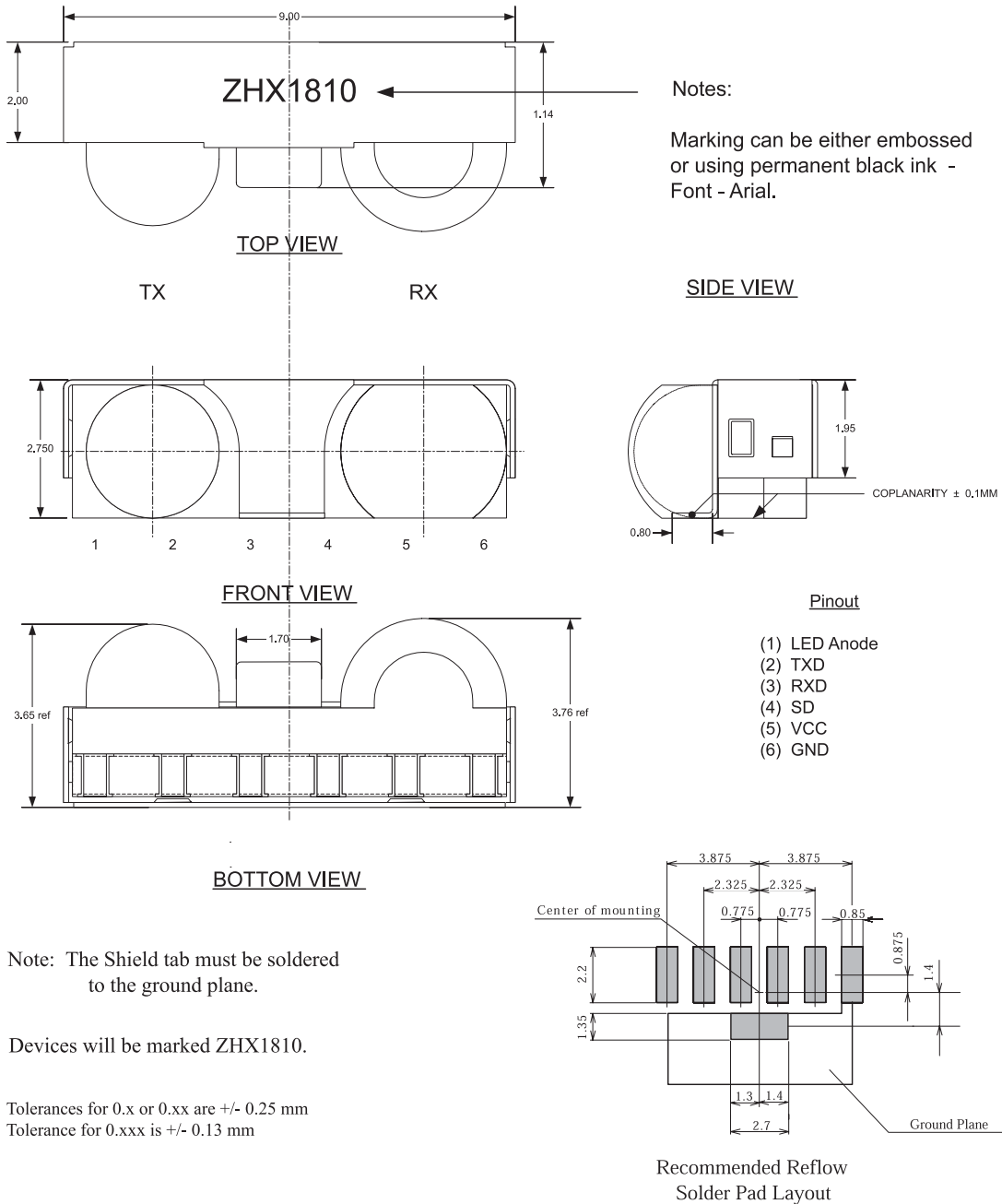

Figure 8. Alternative ZHX1810 Mechanical Drawing

Soldering and Cleaning Recommendations

Follow these recommendations to maintain the performance of the ZHX1810 transceiver.

Reflow Soldering

- Reflow soldering paste is recommended:
Melting temperature: 178 °C ~ 192 °C
Composition: Sn 63%, Pb 37%
- The recommended thickness of the metal mask is between 0.2 mm and 0.25 mm for screen printing.
- Number of soldering times: 2 times *maximum*
- The temperature profile at the top surface of ZHX1810, shown in Figure 9, is recommended.

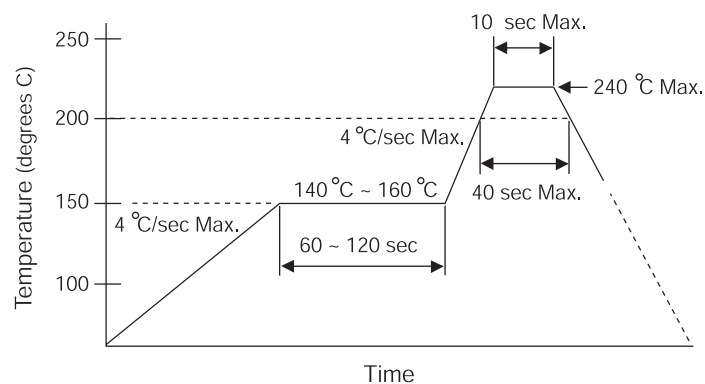

Figure 9. Temperature Profile at the Top Surface of ZHX1810

Manual Soldering

- Use 63/37 or silver solder.
- Use a soldering iron of 25 W or smaller. Adjust the temperature of the soldering iron below 300 °C.
- Finish soldering within 3 seconds.
- Handle only after ZHX1810 has cooled off.

Cleaning

Perform cleaning after soldering under the following conditions:

- Cleaning agent: Alcohol
- Temperature and time: 30 seconds below 50 °C or 3 minutes below 30 °C
- Ultrasonic cleaning: Below 20 W

Packing, Storage, and Baking Recommendations

Follow these recommendations to maintain the performance of the ZHX1810 transceiver.

Storage

To avoid moisture absorption, ZHX1810 reels must remain in the original, unopened moisture-proof packing. Parts must be soldered within 72 hours after unpacking. Reels that have been unpacked, but will not be soldered within 72 hours, must be stored in a desiccator.

Baking

Parts that have been stored over 12 months or unpacked over 72 hours must be baked under the following guidelines.

Reels

60 °C for 48 hours or more

Loose Parts

- 100 °C for 4 hours or more
or
- 125 °C for 2 hours or more
or
- 150 °C for 1 hour or more

Moisture-Proof Packing

In order to avoid moisture absorption during transportation and storage, ZHX1810 reels are packed in aluminum envelopes (see Figure 10) that contain a desiccant with a humidity indicator. While this packaging is an impediment to moisture absorption, it is by no means absolute, and no warranty is implied. The user should store these parts in a controlled environment to prevent moisture entry. Please read the label on the aluminum bag for indicator instructions.

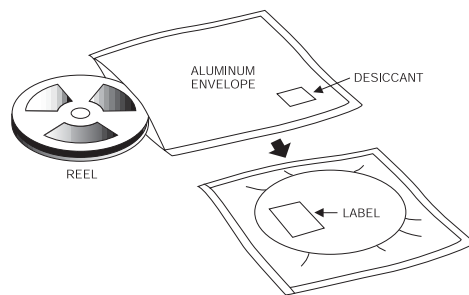

Figure 10. ZHX1810 Packaging

Taping Specifications

Figure 11 shows the reel dimensions for the ZHX1810. Figure 12 shows the tape dimensions and configuration for the ZHX1810.

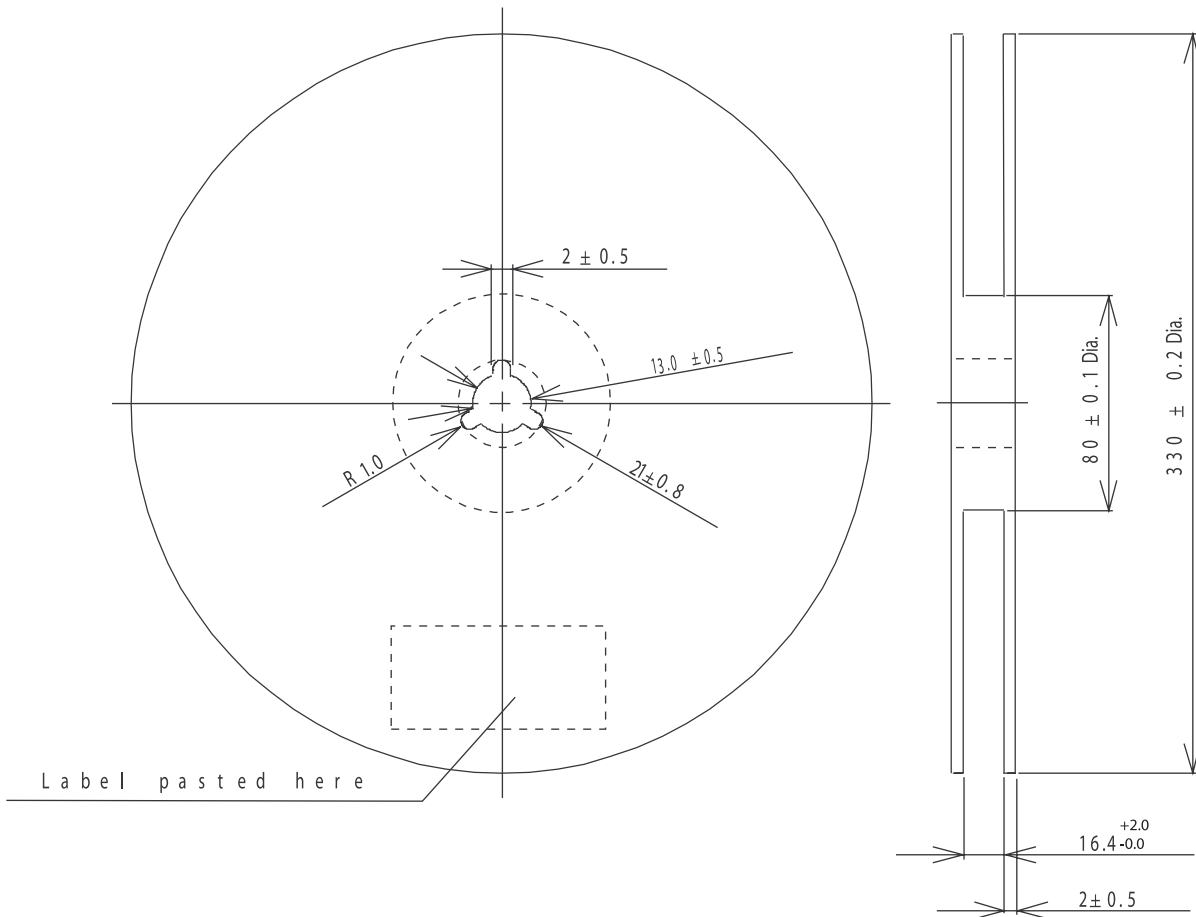
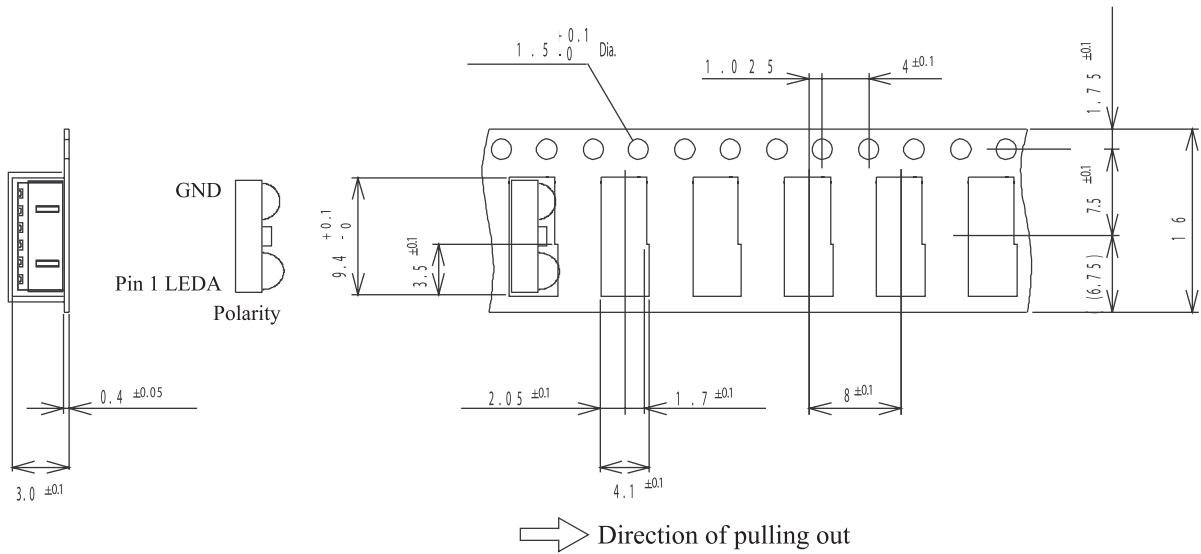

Figure 11. ZHX1810 Reel Dimensions (Unit: mm)

Dimensions of Tape

(Unit: mm)



Configuration of Tape

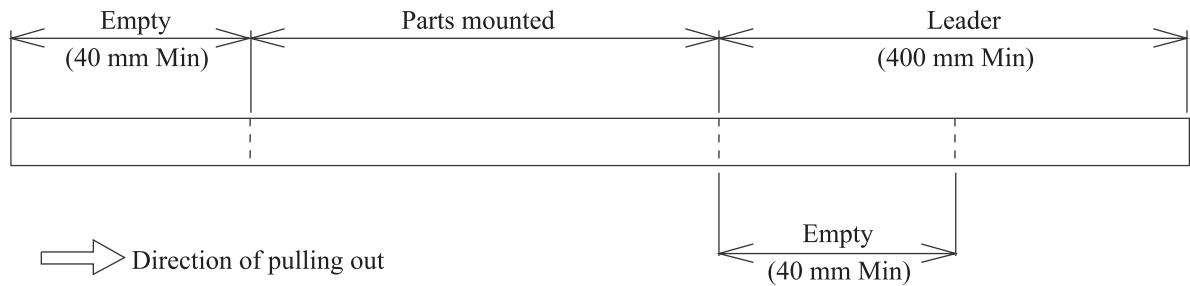

Quantity: 2,000 pcs/reel

Figure 12. ZHX1810 Tape Dimensions and Configuration (Unit: mm)



Ordering Information

To order ZHX1810, use ZiLOG part number ZHX1810MV115THTR.

- ▶ **Note:** In order to ensure the lowest possible lead times, ZiLOG uses two different fab sources for the transceiver IC. Both of these ICs have been extensively tested and qualified to meet the ZHX1810 transceiver specifications.



Customer Feedback Form

If you experience any problems while operating the ZHX1810 transceiver, or if you note any inaccuracies while reading this product specification, please copy and complete this form, then mail or fax it to ZiLOG (see "Return Information," below). We also welcome your suggestions!

Customer Information

Name	Country
Company	Phone
Address	Fax
City/State/Zip	email

Product Information

Serial # or Board Fab #/Rev #
Software Version
Document Number
Host Computer Description/Type

Return Information

ZiLOG
System Test/Customer Support
532 Race Street
San Jose, CA 95126-3432
Fax: (408) 558-8300
Email: zservice@zillog.com

Problem Description or Suggestion

Provide a complete description of the problem or your suggestion. If you are reporting a specific problem, include all steps leading up to the occurrence of the problem. Attach additional pages as necessary.
