

Preliminary W541E260 Data Sheet



4-BIT FLASH EPROM MICROCONTROLLER

Table of Contents-

1. GENERAL DESCRIPTION	2
2. FEATURES	2
3. BLOCK DIAGRAM	4
4. PIN CONFIGURATION	5
5. PIN DESCRIPTION	6
6. ELECTRICAL CHARACTERISTICS	7
6.1 Absolute Maximum Ratings	7
6.2 DC Characteristics	7
6.3 AC Characteristics	9
7. APPLICATION CIRCUIT	10
8. PACKAGE DIMENSIONS	11
8.1 80-Lead QFP	11
9. REVISION HISTORY	12

1. GENERAL DESCRIPTION

The W541E260 is fully compatible with W741E260 in terms of pin assignment and IC function. It is a high-performance 4-bit microcontroller (μC) that provides an LCD driver and the flash EEPROM for the program memory. The device contains a 4-bit ALU, two 8-bit timers, two dividers (for two oscillators) in dual-clock operation, a 32×4 LCD driver, and five 4-bit I/O ports (including 1 output port for LED driving). There are also five interrupt sources and a 8-level subroutine nesting for interrupt applications. The W541E260 operates on very low current and has three power reduction modes, hold mode and stop mode in single-clock operation and the dual-clock slow operation, which help to minimize power dissipation.

This chip is available for W541C250 and W541C260 bodies, which can be selected by option code. The W541E260 is suitable for end product manufacturer engineering testing and earlier samples before mass production.

2. FEATURES

- Operating voltage: 2.4V to 5.5V (LCD drive voltage: 3.0V, or 4.5V)
- Crystal/Ceramic oscillator: up to 4 MHz
- RC oscillator: up to 4 MHz
- Dual-clock operation is selected by code option
- Main oscillator
 - Crystal or RC oscillation circuit can be selected by code option
 - In crystal mode, high-frequency (400 KHz to 4 MHz) or low-frequency (32.768 KHz) oscillation should be selected by code option
 - In RC mode, attention must be paid to the high/low frequency oscillation option, because the LCD driver frequency and the ROM code emulation time are related to this option.
- Sub-oscillator
 - Connect to 32768 Hz crystal only
 - Used in dual-clock operation
- Memory
 - 2048 x 16-bit program flash EEPROM (including 2K x 4-bit look-up table)
 - 128 x 4-bit data RAM (including 16 working registers)
 - 32 x 4 LCD data RAM
- 21 input/output pins
 - Ports for input only: 2 ports/8 pins
 - Input/output ports: 2 ports/8 pins
 - High sink current for LED driving: 1 port/4 pins
 - MFP output pin: 1 pin (MFP)
 - Do not be floating when it is as input or output open-drain (NMOS type).
- Power-down mode
 - Hold function: no operation (excluding main oscillator and sub-oscillator)
 - Stop function: no operation (excluding sub-oscillator)



- Dual-clock slow operation mode: system is operated by the sub-oscillator (Fosc = Fs and Fm is stopped)
- Five types of interrupts
 - Four internal interrupts (Divider0, Divider1, Timer0, Timer1) for W541C260 body; three internal interrupts (Divider0, Timer0, Timer1) for W541C250 body.
 - One external interrupt (RC Port) for W541C260 body; two external interrupts (RC port and $\overline{\text{INT}}$ pin) for W541C250 body.
- LCD driver output
 - 32 segment x 4 common
 - Static, 1/2 duty (1/2 bias), 1/3 duty (1/2 or 1/3 bias), 1/4 duty (1/3 bias) driving mode can be selected
 - LCD driver output pins can be used as DC output port by code option
 - Clock source can be main oscillator clock in the single-clock operation mode, or sub-oscillator clock in the dual-clock operation mode; operation mode is selected by code option
- MFP output pin
 - Output is software selectable as modulating or non-modulating frequency
 - Works as frequency output specified by Timer 1
- Two built-in 14-bit frequency dividers
 - Divider0: the clock source is the output of the main oscillator
 - Divider1: the clock source is the output of the sub-oscillator
- Two built-in 8-bit programmable countdown timers
 - Timer 0: one of two internal clock frequencies (Fosc/4 or Fosc/1024) can be selected
 - Timer 1: includes an auto-reload function and one of two internal clock frequencies (Fosc or Fosc/64) can be selected, or falling edge of pin RC.0 can be selected (output through MFP pin)
- Built-in 18/14-bit watchdog timer selectable for system reset
 - Enable/Disable the watchdog timer can be controlled by command or by option code; the control source (command or option code) can be determined by another option code
- Powerful instruction set: 115 instructions for W541C260 body
 - 119 instructions for W541C250 body
- 8-level subroutine (include interrupt) nesting
- Up to 1 μS instruction cycle (with 4 MHz operating frequency)
- Packaged in 80-pin QFP

3. BLOCK DIAGRAM

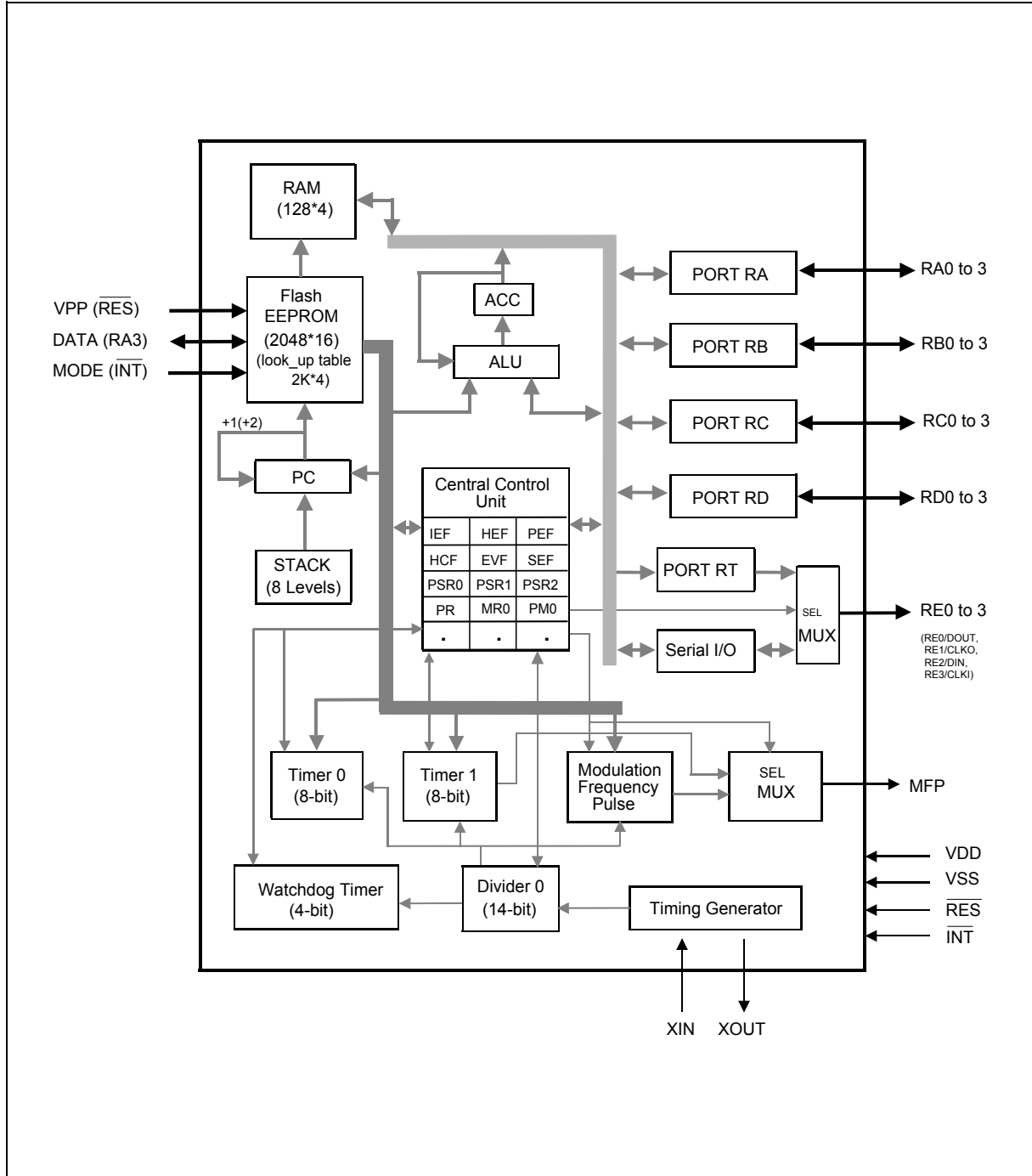



4. PIN CONFIGURATION

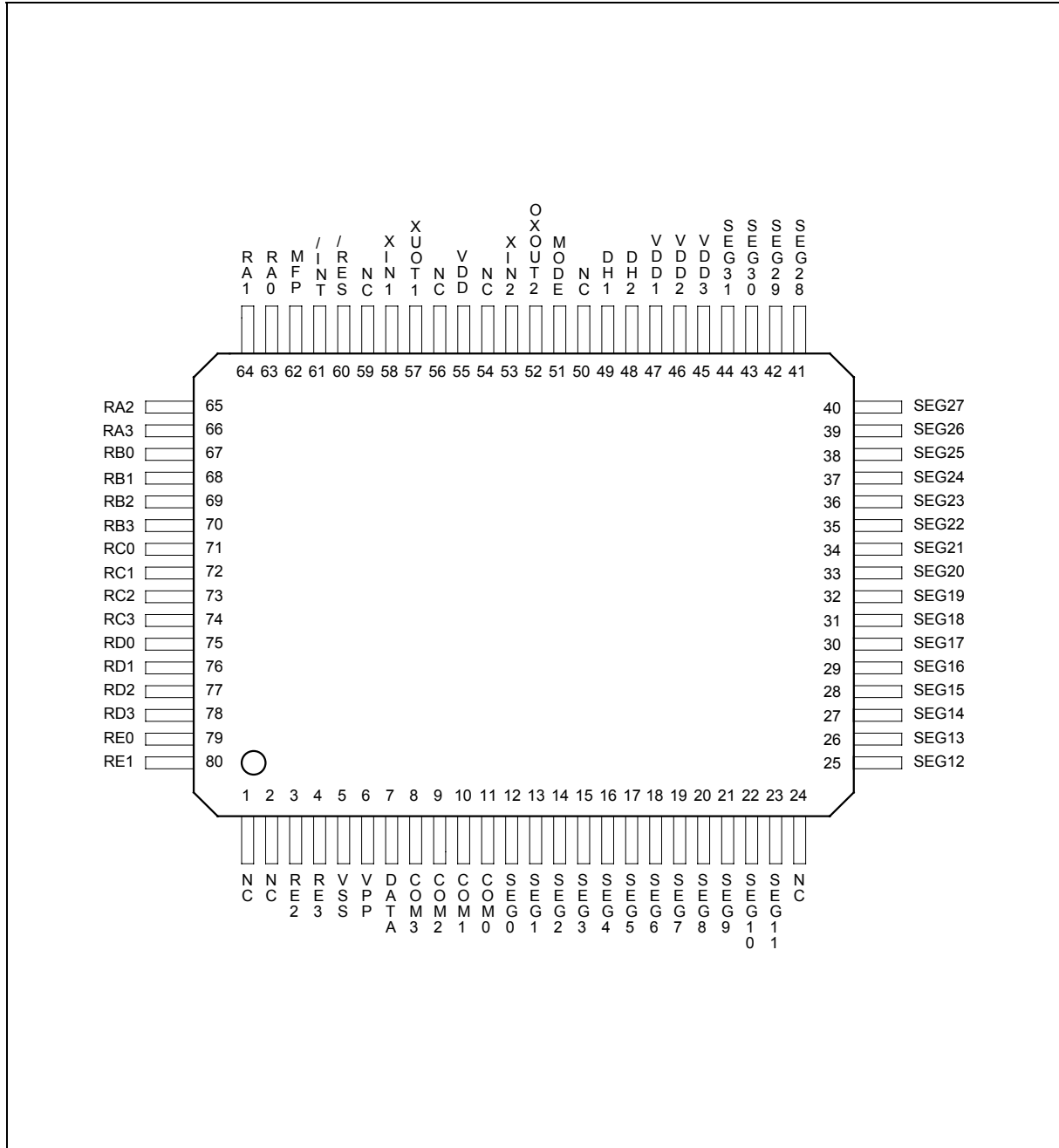

5. PIN DESCRIPTION

SYMBOL	I/O	FUNCTION																									
XIN1	I	Input pin for oscillator. Connected to crystal or resistor to generate system clock by code option. External 10~20pF capacitor uses to get accurate freq in crystal mode.																									
XOUT1	O	Output pin for oscillator. Connected to crystal or resistor to generate system clock by code option. 20pF capacitor is built in internal for crystal mode.																									
XIN2	I	Input pin for sub-oscillator. Connected to 32.768 KHz crystal. External 10~20pF capacitor uses to get accurate freq in crystal mode.																									
XOUT2	O	Output pin for sub-oscillator with internal oscillation capacitor. Built-in 20pF capacitor. Connected to 32.768 KHz crystal.																									
RA0 to RA3	I/O	Input/Output port. Input/output mode specified by port mode 1 register (PM1).																									
RB0 to RB3	I/O	Input/Output port. Input/output mode specified by port mode 2 register (PM2).																									
RC0 to RC3	I	4-bit port for input only. Each pin has an independent interrupt capability.																									
RD0 to RD3	I	4-bit port for input only.																									
RE0 to RE3	O	Output port only. This port provides high sink current to drive LEDs.																									
MFP	O	Output pin only. This pin can output modulating or nonmodulating frequency, or Timer 1 clock output specified by mode register 1 (MR1).																									
$\overline{\text{RES}}$	I	System reset pin with pull-high resistor.																									
$\overline{\text{INT}}$	I	External interrupt pin with pull-high resistor. This pin is bonding option for the W541C250 body.																									
SEG0 to SEG31	O	LCD segment output pins. Also can be used as DC output ports specified by option codes.																									
COM0 to COM3	O	LCD common signal output pins. <table border="1" data-bbox="532 1436 1079 1625"> <thead> <tr> <th></th> <th>Static</th> <th>1/2 Duty</th> <th>1/3 Duty</th> <th>1/4 Duty</th> </tr> </thead> <tbody> <tr> <td>COM0</td> <td>Used</td> <td>Used</td> <td>Used</td> <td>Used</td> </tr> <tr> <td>COM1</td> <td>Not Used</td> <td>Used</td> <td>Used</td> <td>Used</td> </tr> <tr> <td>COM2</td> <td>Not Used</td> <td>Not Used</td> <td>Used</td> <td>Used</td> </tr> <tr> <td>COM3</td> <td>Not Used</td> <td>Not Used</td> <td>Not Used</td> <td>Used</td> </tr> </tbody> </table> <p>The LCD alternating frequency can be selected by code option.</p>		Static	1/2 Duty	1/3 Duty	1/4 Duty	COM0	Used	Used	Used	Used	COM1	Not Used	Used	Used	Used	COM2	Not Used	Not Used	Used	Used	COM3	Not Used	Not Used	Not Used	Used
	Static	1/2 Duty	1/3 Duty	1/4 Duty																							
COM0	Used	Used	Used	Used																							
COM1	Not Used	Used	Used	Used																							
COM2	Not Used	Not Used	Used	Used																							
COM3	Not Used	Not Used	Not Used	Used																							
DH1, DH2	I	Connection terminals for voltage doublers (halves) capacitor.																									
VDD1, VDD2, VDD3	I	Positive (+) supply voltage terminal. Refer to Functional Description.																									



Pin description, continued

SYMBOL	I/O	FUNCTION
VDD	I	Positive power supply (+).
VSS	I	Negative power supply (-).
VPP	I	Voltage control pin for the flash EEPROM programming, erasing and verifying. This pin has a built-in pull-low resistor.
MODE	I	Mode selection pin for the flash EEPROM programming, erasing and verifying. This pin has a built-in pull-low resistor.
DATA	I/O	Data I/O pin for the flash EEPROM programming and verifying. This pin has a built-in pull-low resistor.

6. ELECTRICAL CHARACTERISTICS

6.1 Absolute Maximum Ratings

PARAMETER	RATING	UNIT
Supply Voltage to Ground Potential	-0.3 to +7.0	V
Applied Input/Output Voltage	-0.3 to +7.0	V
Power Dissipation	120	mW
Ambient Operating Temperature	0 to +70	°C
Storage Temperature	-55 to +150	°C

Note: Exposure to conditions beyond those listed under Absolute Maximum Ratings may adversely affect the life and reliability of the device.

6.2 DC Characteristics

(VDD-VSS = 3.0V, Fm = 4.19 MHz, Fs = 32.768 KHz, Ta = 25° C, LCD on; unless otherwise specified)

PARAMETER	SYM.	CONDITIONS	MIN.	TYP.	MAX.	UNIT
Op. Voltage	VDD	-	2.4	-	5.5	V
Op. Current (Crystal type)	IOP1	No load (Ext-V) In dual-clock normal operation	-	0.6	2.5	mA
Op. Current (RC type)	IOP2	No load (Ext-V) In dual-clock normal operation	-	1	4	mA
Op. Current (Crystal type)	IOP3	No load (Ext-V) In dual-clock slow operation and Fm is stopped	-	8.5	20	μA



DC Characteristics, continued

PARAMETER	SYM.	CONDITIONS	MIN.	TYP.	MAX.	UNIT
Hold Current (Crystal type)	IHM1	Hold mode No load (Ext-V) In dual-clock normal operation	-	280	450	μA
Hold Current (RC type)	IHM2	Hold mode No load (Ext-V) In dual-clock normal operation	-	500	600	μA
Hold Current (Crystal type)	IHM3	Hold mode No load (Ext-V) In dual-clock slow operation and Fm is stopped	-	4.0	6	μA
Stop Current (Crystal type)	ISM1	Stop mode No load (Ext-V) In dual-clock normal operation	-	4.0	6	μA
Stop Current (Crystal type)	ISM2	Stop mode No load (Ext-V) In single-clock operation	-	0.1	2	μA
Input Low Voltage	VIL	-	VSS	-	0.3 VDD	V
Input High Voltage	VIH	-	0.7 VDD	-	VDD	V
MFP Output Low Voltage	VML	IOL = 3.5 mA	-	-	0.4	V
MFP Output High Voltage	VMH	IOH = 3.5 mA	2.4	-	-	V
Port RA, RB Output Low Voltage	VABL	IOL = 2.0 mA	-	-	0.4	V
Port RA, RB Output high Voltage	VABH	IOH = 2.0 mA	2.4	-	-	V
LCD Supply Current	ILCD	All Seg. ON	-	-	6	μA
SEG0-SEG31 Sink Current (Used as LCD output)	IOL1	VOL = 0.4V VLCD = 0.0V	0.4	-	-	μA
SEG0-SEG31 Drive Current (Used as LCD output)	IOH1	VOH = 2.4V VLCD = 3.0V	0.3	-	-	μA
Segment output low voltage (Used as DC output)	VSL	IOL = 0.6 mA	-	-	0.4	V
Segment output high voltage (Used as DC output)	VSH	IOH = 3 μA	2.4	-	-	V



DC Characteristics, continued

PARAMETER	SYM.	CONDITIONS	MIN.	TYP.	MAX.	UNIT
Port RE Sink Current	IEL	VOL = 0.9V	9	-	-	mA
Port RE Source Current	IEH	VOH = 2.4V	0.4	1.2	-	mA
Input Port Pull-up Resistor	RCD	Port RC, RD	100	350	1000	KΩ
$\overline{\text{INT}}$ Pull-up Resistor	RINT	-	50	250	1000	KΩ
$\overline{\text{RES}}$ Pull-up Resistor	RRES	-	20	100	500	KΩ
VPP Pull-down Resistor	RVPP	VDD = 5V	1.5	2	2.5	MΩ
MODE Pull-down Resistor	RMODE	VDD = 5V	1.5	2	2.5	MΩ
DATA Pull-down Resistor	RDATA	VDD = 5V	50	100	150	KΩ

6.3 AC Characteristics

(VDD-VSS = 3.0V, Ta = 25° C; unless otherwise specified)

PARAMETER	SYM.	CONDITIONS	MIN.	TYP.	MAX.	UNIT
Op. Frequency	FOSC	RC type	-	-	4000	KHz
		Crystal type 1 (Option low speed type)	-	32.768	-	
		Crystal type 2 (Option high speed type)	400	-	3580	
Frequency Deviation by Voltage Drop for RC Oscillator	$\frac{\Delta f}{f}$	$\frac{f(3V) - f(2.4V)}{f(3V)}$	-	-	10	%
Instruction Cycle Time	TI	One machine cycle	-	4/FOSC	-	mS
Reset Active Width	TRAW	FOSC = 32.768 KHz	1	-	-	μS
Interrupt Active Width	TIAW	FOSC = 32.768 KHz	1	-	-	μS

7. APPLICATION CIRCUIT

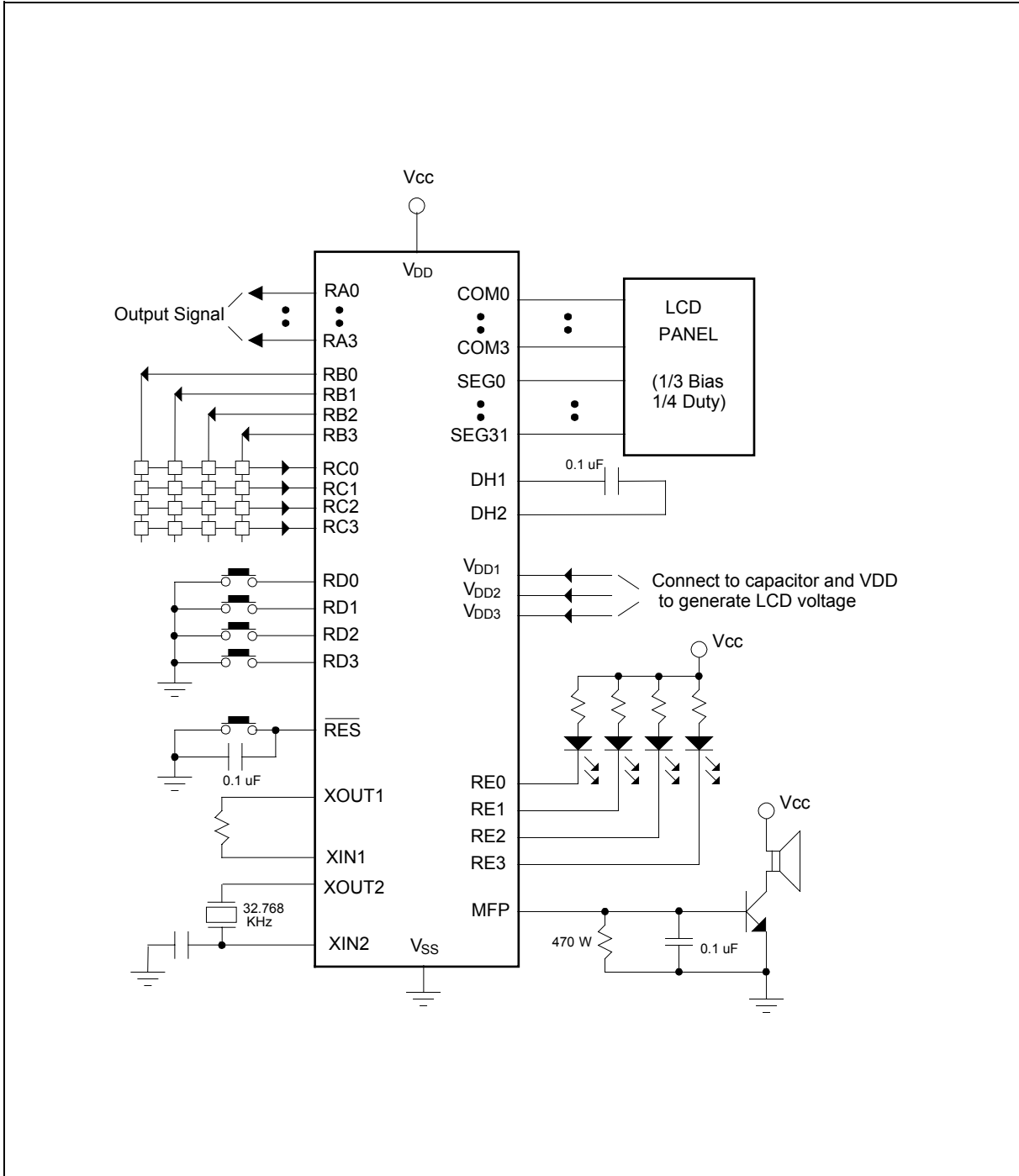



8. PACKAGE DIMENSIONS

8.1 80-Lead QFP

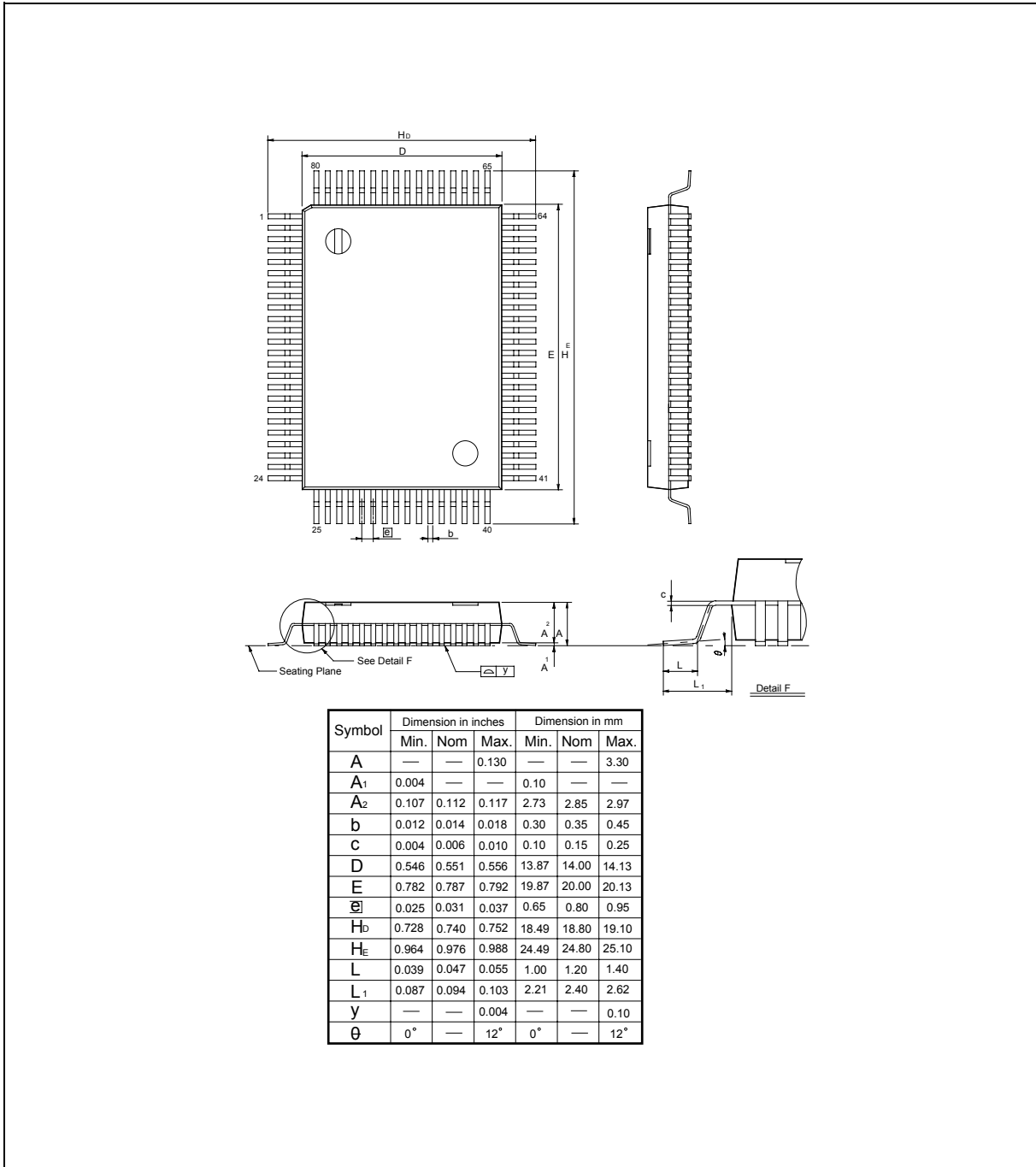



9. REVISION HISTORY

VERSION	DATE	PAGE	DESCRIPTION
A1	June 2, 2003	-	Initial Issued



Headquarters

No. 4, Creation Rd. III,
Science-Based Industrial Park,
Hsinchu, Taiwan
TEL: 886-3-5770066
FAX: 886-3-5665577
<http://www.winbond.com.tw/>

Taipei Office

9F, No.480, Rueiguang Rd.,
Neihu District, Taipei, 114,
Taiwan, R.O.C.
TEL: 886-2-8177-7168
FAX: 886-2-8751-3579

Winbond Electronics Corporation America

2727 North First Street, San Jose,
CA 95134, U.S.A.
TEL: 1-408-9436666
FAX: 1-408-5441798

Winbond Electronics Corporation Japan

7F Daini-ueno BLDG, 3-7-18
Shinyokohama Kohoku-ku,
Yokohama, 222-0033
TEL: 81-45-4781881
FAX: 81-45-4781800

Winbond Electronics (Shanghai) Ltd.

27F, 2299 Yan An W. Rd. Shanghai,
200336 China
TEL: 86-21-62365999
FAX: 86-21-62365998

Winbond Electronics (H.K.) Ltd.

Unit 9-15, 22F, Millennium City,
No. 378 Kwun Tong Rd.,
Kowloon, Hong Kong
TEL: 852-27513100
FAX: 852-27552064

*Please note that all data and specifications are subject to change without notice.
All the trade marks of products and companies mentioned in this data sheet belong to their respective owners.*