

April 1994

## CMOS Voltage Converter

### Features

- No External Diode Needed Over Entire Temperature Range
- Pin Compatible With ICL7660
- Simple Conversion of +15V Supply to -15V Supply
- Simple Voltage Multiplication ( $V_{OUT} = (-)nV_{IN}$ )
- 99.9% Typical Open Circuit Voltage Conversion Efficiency
- 96% Typical Power Efficiency
- Wide Operating Voltage Range 4.5V to 20.0V
- Easy to Use - Requires Only 2 External Non-Critical Passive Components

### Applications

- On Board Negative Supply for Dynamic RAMs
- Localized  $\mu$ Processor (8080 Type) Negative Supplies
- Inexpensive Negative Supplies
- Data Acquisition Systems
- Up to -20V for Op Amps

### Description

The Harris ICL7662 is a monolithic high-voltage CMOS power supply circuit which offers unique performance advantages over previously available devices. The ICL7662 performs supply voltage conversion from positive to negative for an input range of +4.5V to +20.0V, resulting in complementary output voltages of -4.5V to -20V. Only 2 noncritical external capacitors are needed for the charge pump and charge reservoir functions. The ICL7662 can also function as a voltage doubler, and will generate output voltages up to +38.6V with a +20V input.

Contained on chip are a series DC power supply regulator, RC oscillator, voltage level translator, four output power MOS switches. A unique logic element senses the most negative voltage in the device and ensures that the output N-Channel switch source-substrate junctions are not forward biased. This assures latchup free operation.

The oscillator, when unloaded, oscillates at a nominal frequency of 10kHz for an input supply voltage of 15.0V. This frequency can be lowered by the addition of an external capacitor to the "OSC" terminal, or the oscillator may be overdriven by an external clock.

The "LV" terminal may be tied to GROUND to bypass the internal series regulator and improve low voltage (LV) operation. At medium to high voltages (+10V to +20V), the LV pin is left floating to prevent device latchup.

### Pinouts

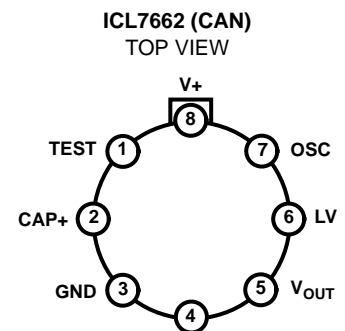
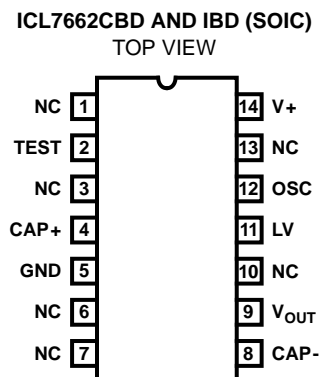
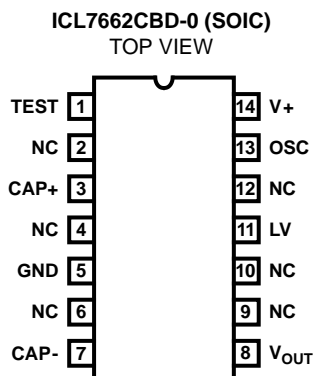
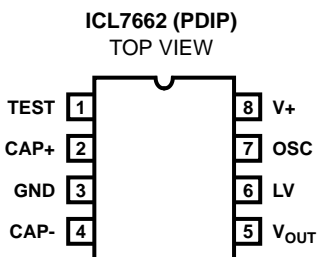

# ICL7662

## Ordering Information

PART NUMBER	TEMPERATURE RANGE	PACKAGE
ICL7662CTV	0°C to +70°C	8 Pin Metal Can
ICL7662CPA		8 Lead Plastic DIP
ICL7662CBD-0		14 Lead SOIC (N)
ICL7662CBD		14 Lead SOIC (N)
ICL7662ITV	-40°C to +85°C	8 Pin Metal Can
ICL7662IPA		8 Lead Plastic DIP
ICL7662IBD		14 Lead SOIC (N)
ICL7662MTV (Note 1)	-55°C to +125°C	8 Pin Metal Can

NOTE:

1. Add /883 to part number if /883B processing is required.

## Functional Block Diagram

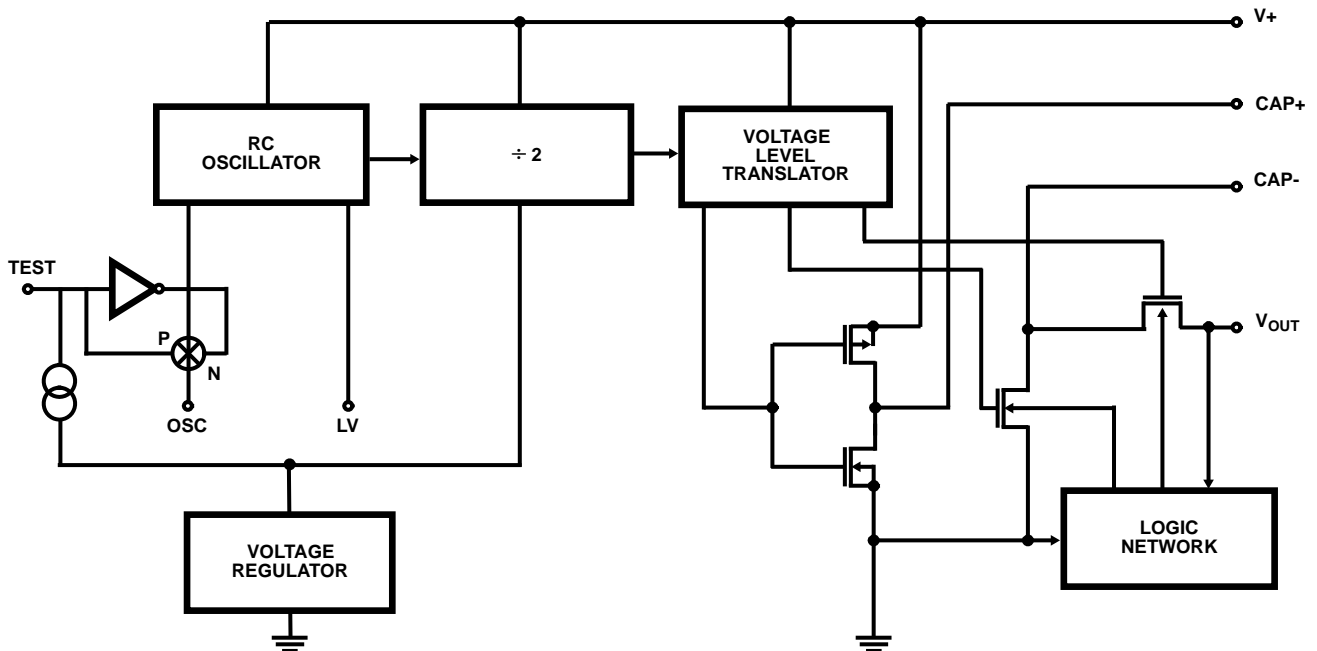

## Specifications ICL7662

### Absolute Maximum Ratings

Supply Voltage	22V
Oscillator Input Voltage	-0.3V to (V+ +0.3V) for V+ < 10V
	(V+ -10V) to (V+ +0.3V) for V+ > 10V
	(Note 1)
Current Into LV (Note 1)	20μA for V+ > 10V
Output Short Duration	Continuous

### Thermal Information

Thermal Resistance	$\theta_{JA}$	$\theta_{JC}$
Plastic DIP Package	150°C/W	-
Plastic SOIC Package	120°C/W	-
Metal Can	156°C/W	68°C/W
Lead Temperature (Soldering, 10s)	300°C	
	(SOIC - Lead Tips Only)	

*CAUTION: Stresses above those listed in "Absolute Maximum Ratings" may cause permanent damage to the device. This is a stress only rating and operation of the device at these or any other conditions above those indicated in the operational sections of this specification is not implied.*

### Electrical Specifications $V_+ = 15V, T_A = +25^\circ C, C_{OSC} = 0$ , Unless Otherwise Specified. Refer to Figure 14.

PARAMETER	SYMBOL	TEST CONDITIONS	MIN	TYP	MAX	UNITS	
Supply Voltage Range - Lo	V+L	$R_L = 10k\Omega, LV = GND$	Min < $T_A$ < Max	4.5	-	11	V
Supply Voltage Range - Hi	V+H	$R_L = 10k\Omega, LV = Open$	Min < $T_A$ < Max	9	-	20	V
Supply Current	I+	$R_L = \infty, LV = Open$	$T_A = +25^\circ C$	-	0.25	0.60	mA
			$0^\circ C < T_A < +70^\circ C$ $-40^\circ C < T_A < +85^\circ C$	-	0.30	0.85	mA
			$-55^\circ C < T_A < +125^\circ C$	-	0.40	1.0	mA
Output Source Resistance	$R_O$	$I_O = 20mA, LV = Open$	$T_A = +25^\circ C$	-	60	100	$\Omega$
			$0^\circ C < T_A < +70^\circ C$ $-40^\circ C < T_A < +85^\circ C$	-	70	120	$\Omega$
			$-55^\circ C < T_A < +125^\circ C$	-	90	150	$\Omega$
Supply Current	I+	$V_+ = 5V, R_L = \infty, LV = GND$	$T_A = +25^\circ C$	-	20	150	$\mu A$
			$0^\circ C < T_A < +70^\circ C$ $-40^\circ C < T_A < +85^\circ C$	-	25	200	$\mu A$
			$-55^\circ C < T_A < +125^\circ C$	-	30	250	$\mu A$
Output Source Resistance	$R_O$	$V_+ = 5V, I_O = 3mA, LV = GND$	$T_A = +25^\circ C$	-	125	200	$\Omega$
			$0^\circ C < T_A < +70^\circ C$ $-40^\circ C < T_A < +85^\circ C$	-	150	250	$\Omega$
			$-55^\circ C < T_A < +125^\circ C$	-	200	350	$\Omega$
Oscillator Frequency	FOSC			-	10	-	kHz
Power Efficiency	$P_{EFF}$	$R_L = 2K\Omega$	$T_A = +25^\circ C$	93	96	-	%
			Min < $T_A$ < Max	90	95	-	%
Voltage Conversion Efficiency	$V_o E_f$	$R_L = \infty$	Min < $T_A$ < Max	97	99.9	-	%
Oscillator Sink or Source Current	$I_{OSC}$	$V_+ = 5V (V_{OSC} = 0V \text{ to } +5V)$		-	0.5	-	$\mu A$
		$V_+ = 15V (V_{OSC} = +5V \text{ to } +15V)$		-	4.0	-	$\mu A$

#### NOTES:

- Connecting any terminal to voltages greater than V+ or less than GND may cause destructive latchup. It is recommended that no inputs from sources operating from external supplies be applied prior to "power up" of ICL7660S.
- Pin 1 is a Test pin and is not connected in normal use. When the TEST pin is connected to V+, an internal transmission gate disconnects any external parasitic capacitance from the oscillator which would otherwise reduce the oscillator frequency from its nominal value.

**Performance Curves** (See Figure 14, Test Circuit)

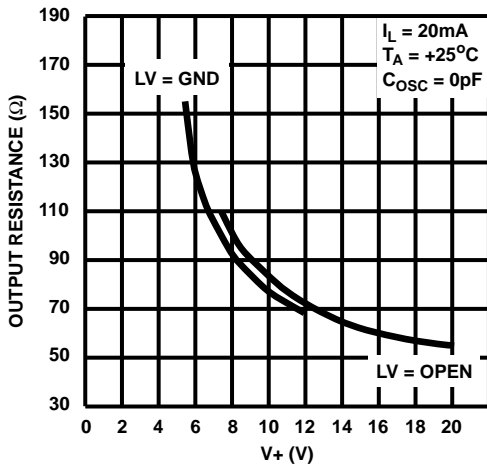

FIGURE 1. OUTPUT SOURCE RESISTANCE AS A FUNCTION OF SUPPLY VOLTAGE

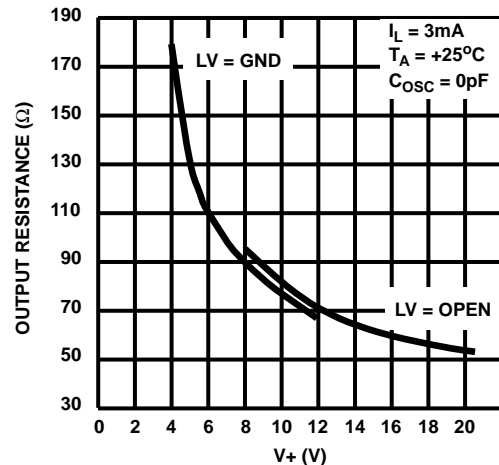

FIGURE 2. OUTPUT SOURCE RESISTANCE AS A FUNCTION OF SUPPLY VOLTAGE

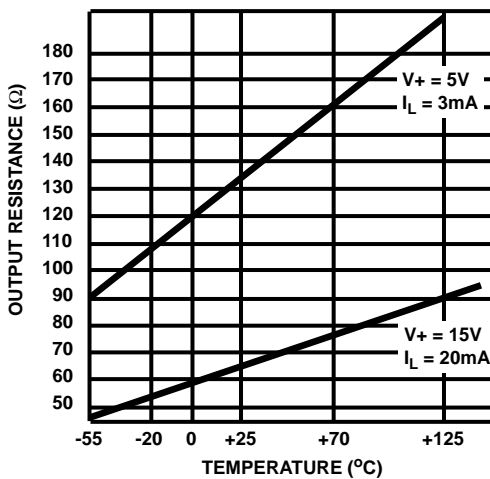

FIGURE 3. OUTPUT SOURCE RESISTANCE AS A FUNCTION OF TEMPERATURE

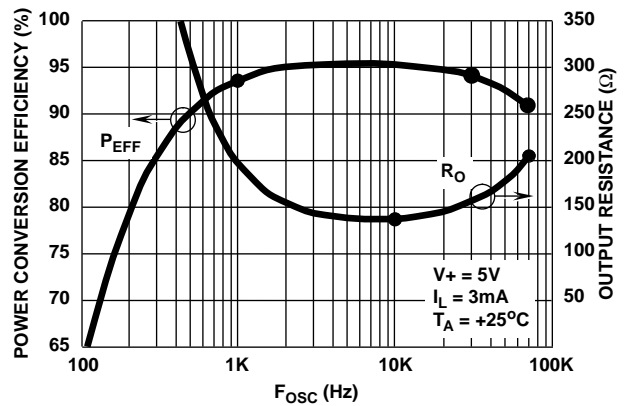

FIGURE 4. POWER CONVERSION EFFICIENCY AND OUTPUT SOURCE RESISTANCE AS A FUNCTION OF OSCILLATOR FREQUENCY

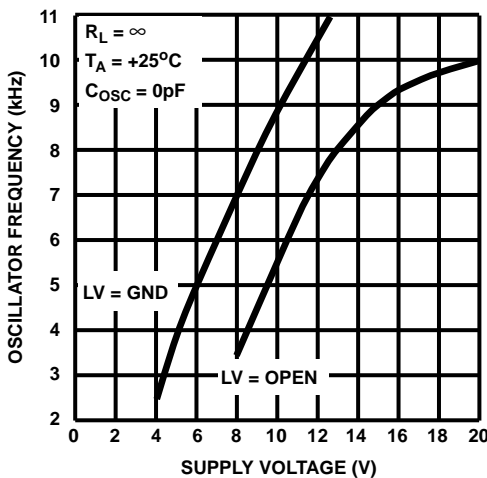

FIGURE 5. OSCILLATOR FREQUENCY vs SUPPLY VOLTAGE

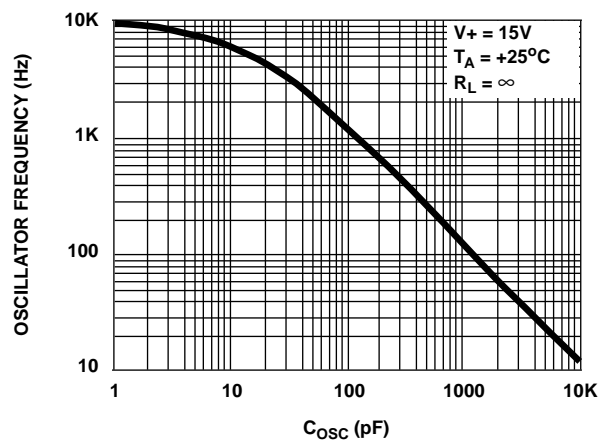

FIGURE 6. FREQUENCY OF OSCILLATION AS A FUNCTION OF EXTERNAL OSCILLATOR CAPACITANCE

NOTE: All typical values have been characterized but are not tested.

Performance Curves (See Figure 14, Test Circuit) (Continued)

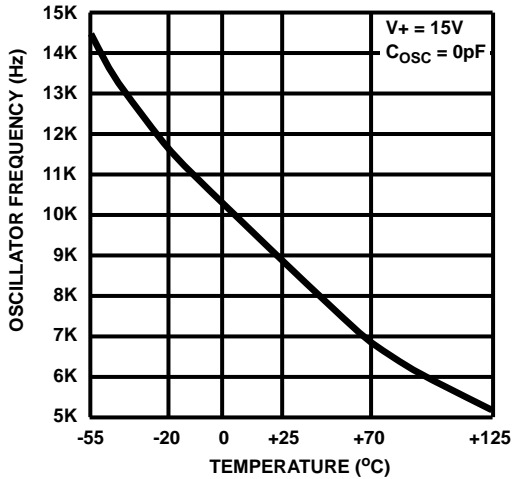

FIGURE 7. UNLOADED OSCILLATOR FREQUENCY AS A FUNCTION OF TEMPERATURE

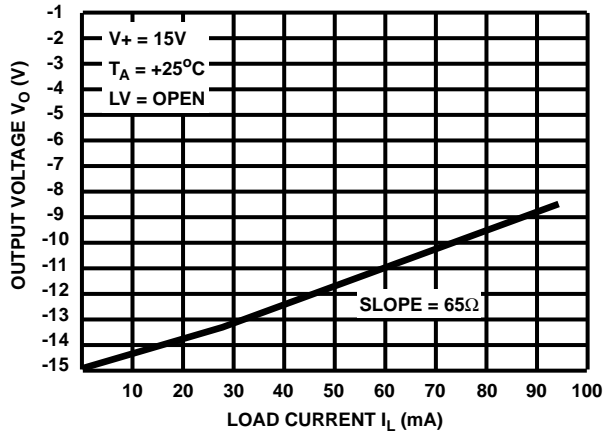

FIGURE 8. OUTPUT VOLTAGE AS A FUNCTION OF LOAD CURRENT

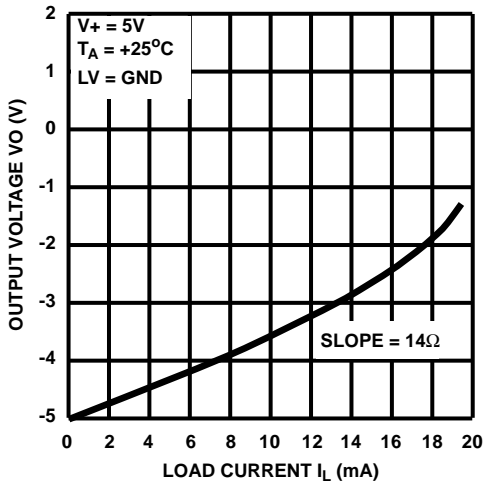

FIGURE 9. OUTPUT VOLTAGE AS A FUNCTION OF LOAD CURRENT

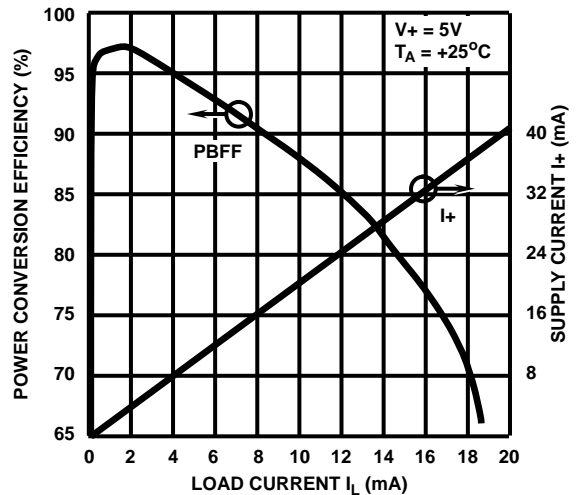

FIGURE 10. SUPPLY CURRENT AND POWER CONVERSION EFFICIENCY AS A FUNCTION OF LOAD

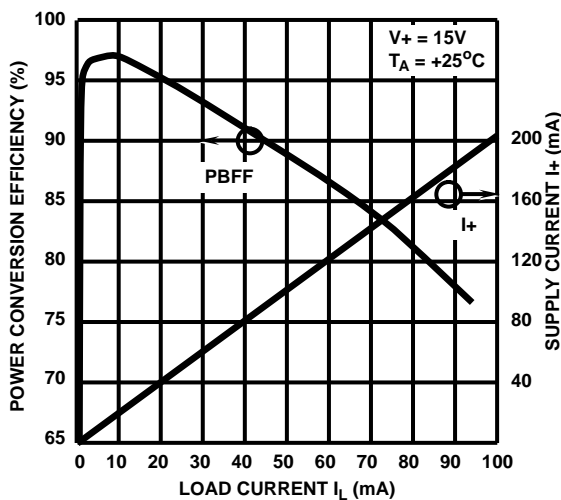

FIGURE 11. SUPPLY CURRENT AND POWER CONVERSION EFFICIENCY AS A FUNCTION OF LOAD CURRENT

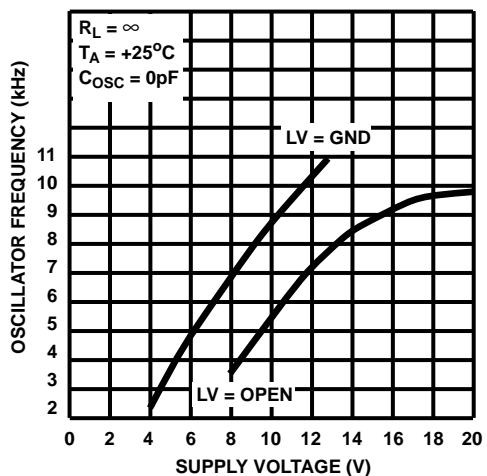
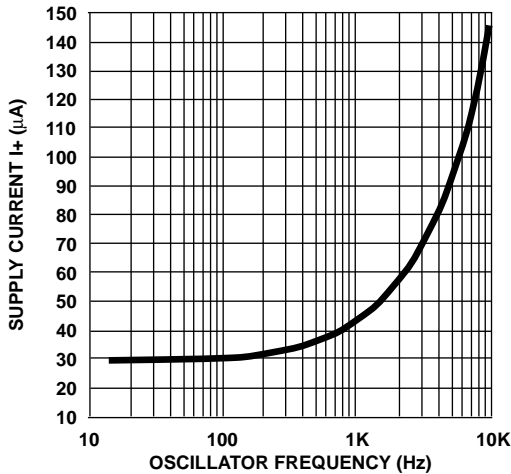

FIGURE 12. FREQUENCY OF OSCILLATION AS A FUNCTION OF SUPPLY VOLTAGE

**Performance Curves** (See Figure 14, Test Circuit) (Continued)



**FIGURE 13. SUPPLY CURRENT AS A FUNCTION OF OSCILLATOR FREQUENCY**

NOTE 4. These curves include in the supply current that current fed directly into the load  $R_L$  from the  $V_+$  (See Figure 14). Thus, approximately half the supply current goes directly to the positive side of the load, and the other half, through the ICL7662, to the negative side of the load. Ideally,  $V_{OUT} \approx 2V_{IN}$ ,  $I_S \approx 2I_L$ , so  $V_{IN} \times I_S \approx V_{OUT} \times I_L$ .

**Circuit Description**

The ICL7662 contains all the necessary circuitry to complete a negative voltage converter, with the exception of 2 external capacitors which may be inexpensive 10µF polarized electrolytic capacitors. The mode of operation of the device may be best understood by considering Figure 15, which shows an idealized negative voltage converter. Capacitor  $C_1$  is charged to a voltage,  $V_+$ , for the half cycle when switches  $S_1$  and  $S_3$  are closed. (Note: Switches  $S_2$  and  $S_4$  are open during this half cycle.) During the second half cycle of operation, switches  $S_2$  and  $S_4$  are closed, with  $S_1$  and  $S_3$  open, thereby shifting capacitor  $C_1$  negatively by  $V_+$  volts. Charge is then transferred from  $C_1$  to  $C_2$  such that the voltage on  $C_2$  is exactly  $V_+$ , assuming ideal switches and no load on  $C_2$ . The ICL7662 approaches this ideal situation more closely than existing non-mechanical circuits.

In the ICL7662, the 4 switches of Figure 15 are MOS power switches;  $S_1$  is a P-Channel device and  $S_2$ ,  $S_3$  and  $S_4$  are N-Channel devices. The main difficulty with this approach is that in integrating the switches, the substrates of  $S_3$  and  $S_4$  must always remain reverse biased with respect to their sources, but not so much as to degrade their "ON" resistances. In addition, at circuit startup, and under output short circuit conditions ( $V_{OUT} = V_+$ ), the output voltage must be sensed and the substrate bias adjusted accordingly. Failure to accomplish this would result in high power losses and probable device latchup.

This problem is eliminated in the ICL7662 by a logic network which senses the output voltage ( $V_{OUT}$ ) together with the level translators, and switches the substrates of  $S_3$  and  $S_4$  to the correct level to maintain necessary reverse bias.

The voltage regulator portion of the ICL7662 is an integral part of the anti-latchup circuitry, however its inherent voltage drop can degrade operation at low voltages. Therefore, to improve low voltage operation the "LV" pin should be connected to GROUND, disabling the regulator. For supply voltages greater than 10V the LV terminal must be left open to insure latchup proof operation, and prevent device damage.

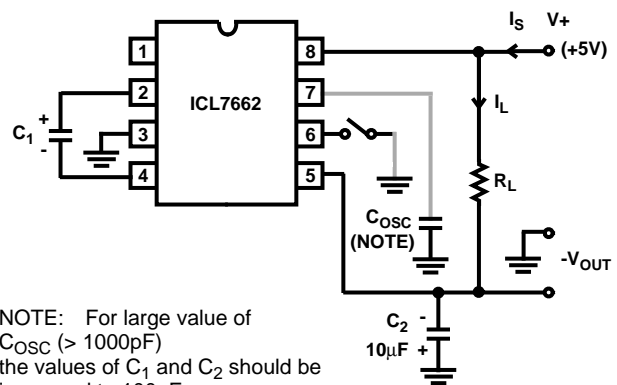

**FIGURE 14. ICL7662 TEST CIRCUIT**

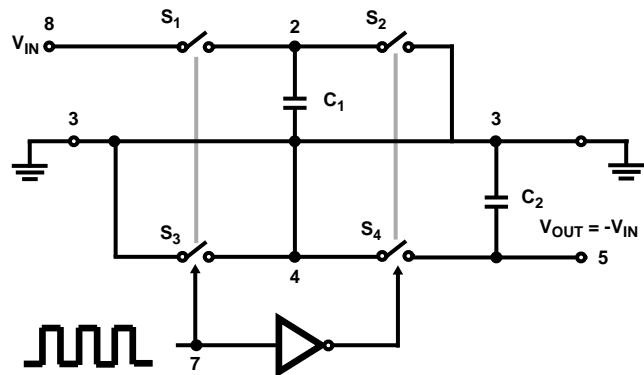

**FIGURE 15. IDEALIZED NEGATIVE CONVERTER**

### Theoretical Power Efficiency Considerations

In theory a voltage multiplier can approach 100% efficiency if certain conditions are met:

- A The drive circuitry consumes minimal power
- B The output switches have extremely low ON resistance and virtually no offset.
- C The impedances of the pump and reservoir capacitors are negligible at the pump frequency.

The ICL7662 approaches these conditions for negative voltage multiplication if large values of  $C_1$  and  $C_2$  are used. **ENERGY IS LOST ONLY IN THE TRANSFER OF CHARGE BETWEEN CAPACITORS IF A CHANGE IN VOLTAGE OCCURS.** The energy lost is defined by:

$$E = 1/2C_1 (V_1^2 - V_2^2)$$

where  $V_1$  and  $V_2$  are the voltages on  $C_1$  during the pump and transfer cycles. If the impedances of  $C_1$  and  $C_2$  are relatively high at the pump frequency (refer to Figure 15) compared to the value of  $R_L$ , there will be a substantial difference in the voltages  $V_1$  and  $V_2$ . Therefore it is not only desirable to make  $C_2$  as large as possible to eliminate output voltage ripple, but also to employ a correspondingly large value for  $C_1$  in order to achieve maximum efficiency of operation.

#### Do's and Don'ts

1. Do not exceed maximum supply voltages.
2. Do not connect LV terminal to GROUND for supply voltages greater than 10V.
3. When using polarized capacitors, the + terminal of  $C_1$  must be connected to pin 2 of the ICL7662 and the + terminal of  $C_2$  must be connected to GROUND.
4. If the voltage supply driving the 7662 has a large source impedance ( $25\Omega - 30\Omega$ ), then a  $2.2\mu\text{F}$  capacitor from pin 8 to ground may be required to limit rate of rise of input voltage to less than  $2\text{V}/\mu\text{s}$ .
5. User should insure that the output (pin 5) does not go more positive than GND (pin 3). Device latch up will occur under these conditions.

A 1N914 or similar diode placed in parallel with  $C_2$  will prevent the device from latching up under these conditions. (Anode pin 5, Cathode pin 3).

### Typical Applications

#### Simple Negative Voltage Converter

The majority of applications will undoubtedly utilize the ICL7662 for generation of negative supply voltages. Figure 16 shows typical connections to provide a negative supply where a positive supply of +4.5V to 20.0V is available. Keep in mind that pin 6 (LV) is tied to the supply negative (GND) for supply voltages below 10V.

The output characteristics of the circuit in Figure 16A can be approximated by an ideal voltage source in series with a resistance as shown in Figure 16B. The voltage source has a value of  $-V_+$ . The output impedance ( $R_O$ ) is a function of the ON resistance of the internal MOS switches (shown in Figure 2), the switching frequency, the value of  $C_1$  and  $C_2$ , and the ESR (equivalent series resistance) of  $C_1$  and  $C_2$ . A good first order approximation for  $R_O$  is:

$$R_O \cong 2(R_{SW1} + R_{SW3} + \text{ESRC}_1) + 2(R_{SW2} + R_{SW4} + \text{ESRC}_1) + \frac{1}{f_{\text{PUMP}} \times C_1} + \text{ESRC}_2$$

$$(f_{\text{PUMP}} = \frac{f_{\text{OSC}}}{2}, R_{\text{SWX}} = \text{MOSFET switch resistance})$$

Combining the four  $R_{\text{SWX}}$  terms as  $R_{\text{SW}}$ , we see that

$$R_O \cong 2 \times R_{\text{SW}} + \frac{1}{f_{\text{PUMP}} \times C_1} + 4 \times \text{ESRC}_1 + \text{ESRC}_2 \Omega$$

$R_{\text{SW}}$ , the total switch resistance, is a function of supply voltage and temperature (See the Output Source Resistance graphs), typically  $24\Omega$  at  $+25^\circ\text{C}$  and 15V, and  $53\Omega$  at  $+25^\circ\text{C}$  and 5V. Careful selection of  $C_1$  and  $C_2$  will reduce the remaining terms, minimizing the output impedance. High value capacitors will reduce the  $1/(f_{\text{PUMP}} \times C_1)$  component, and low FSR capacitors will lower the ESR term. Increasing the oscillator frequency will reduce the  $1/(f_{\text{PUMP}} \times C_1)$  term, but may have the side effect of a net increase in output impedance when  $C_1 > 10\mu\text{F}$  and there is no longer enough time to fully charge the capacitors every cycle. In a typical application where  $f_{\text{OSC}} = 10\text{kHz}$  and  $C = C_1 = C_2 = 10\mu\text{F}$ :

$$R_O \cong 2 \times 23 + \frac{1}{(5 \times 10^3 \times 10 \times 10^{-6})} + 4 \text{ESRC}_1 + \text{ESRC}_2$$

$$R_O \cong 46 + 20 + 5 \times \text{ESRC}_2 \Omega$$

Since the ESRs of the capacitors are reflected in the output impedance multiplied by a factor of 5, a high value could potentially swamp out a low  $1/(f_{\text{PUMP}} \times C_1)$  term, rendering an increase in switching frequency or filter capacitance ineffective. Typical electrolytic capacitors may have ESRs as high as  $10\Omega$ .

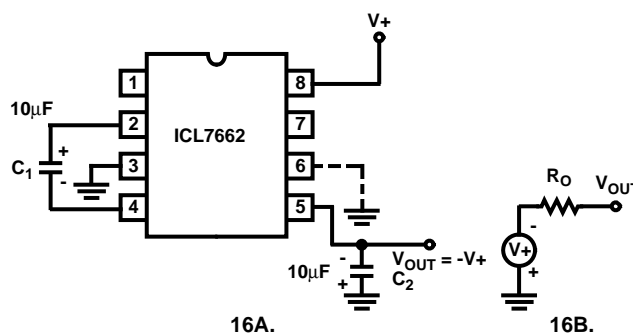

FIGURE 16. SIMPLE NEGATIVE CONVERTER AND ITS OUTPUT EQUIVALENT

**Output Ripple**

ESR also affects the ripple voltage seen at the output. The total ripple is determined by 2V, A and B, as shown in Figure 17. Segment A is the voltage drop across the ESR of C<sub>2</sub> at the instant it goes from being charged by C<sub>1</sub> (current flowing into C<sub>2</sub>) to being discharged through the load (current flowing out of C<sub>2</sub>). The magnitude of this current change is 2 x I<sub>OUT</sub>, hence the total drop is 2 x I<sub>OUT</sub> x ESR C<sub>2</sub>V. Segment B is the voltage change across C<sub>2</sub> during time t<sub>2</sub>, the half of the cycle when C<sub>2</sub> supplies current the load. The drop at B is I<sub>OUT</sub> x t<sub>2</sub>/C<sub>2</sub>V. The peak-to-peak ripple voltage is the sum of these voltage drops:

$$V_{\text{RIPPLE}} \cong \left( \frac{1}{2 \times f_{\text{PUMP}} \times C_2} + 2 \text{ ESR}_{C_2} \times I_{\text{OUT}} \right)$$

Again, a low ESR capacitor will result in a higher performance output.

**Paralleling Devices**

Any number of ICL7662 voltage converters may be

paralleled (Figure 18) to reduce output resistance. The reservoir capacitor, C<sub>2</sub>, serves all devices while each device requires its own pump capacitor, C<sub>1</sub>. The resultant output resistance would be approximately:

$$R_{\text{OUT}} = \frac{R_{\text{OUT}} \text{ (of ICL7662)}}{n \text{ (number of devices)}}$$

**Cascading Devices**

The ICL7662 may be cascaded as shown in Figure 19 to produce larger negative multiplication of the initial supply voltage. However, due to the finite efficiency of each device, the practical limit is 10 devices for light loads. The output voltage is defined by:

$$V_{\text{OUT}} = -n(V_{\text{IN}}),$$

where n is an integer representing the number of devices cascaded. The resulting output resistance would be approximately the weighted sum of the individual ICL7662 R<sub>OUT</sub> values.

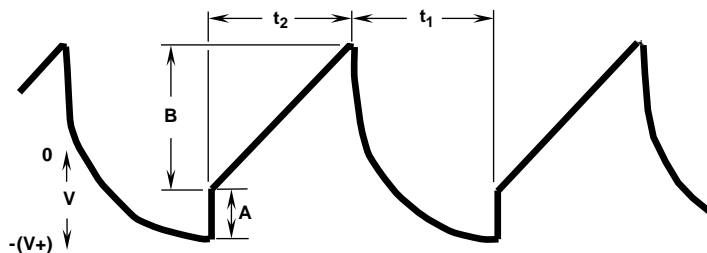

FIGURE 17. OUTPUT RIPPLE

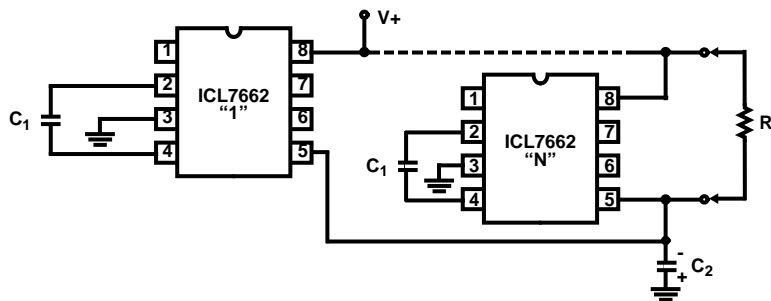

FIGURE 18. PARALLELING DEVICES

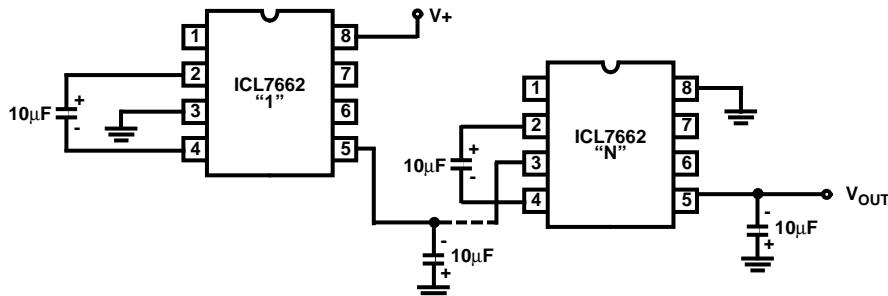

FIGURE 19. CASCADING DEVICES FOR INCREASED OUTPUT VOLTAGE



**Changing the ICL7662 Oscillator Frequency**

It may be desirable in some applications, due to noise or other considerations, to increase the oscillator frequency. This is achieved by overdriving the oscillator from an external clock, as shown in Figure 20. In order to prevent possible device latchup, a 1kW resistor must be used in series with the clock output. In the situation where the designer has generated the external clock frequency using TTL logic, the addition of a 10kW pullup resistor to V+ supply is required. Note that the pump frequency with external clocking, as with internal clocking, will be 1/2 of the clock frequency. Output transitions occur on the positive-going edge of the clock.

It is also possible to increase the conversion efficiency of the ICL7662 at low load levels by lowering the oscillator frequency. This reduces the switching losses, and is achieved by connecting an additional capacitor, COSC, as shown in Figure 21. However, lowering the oscillator frequency will cause an undesirable increase in the impedance of the pump (C<sub>1</sub>) and reservoir (C<sub>2</sub>) capacitors; this is overcome by increasing the values of C<sub>1</sub> and C<sub>2</sub> by the same factor that the frequency has been reduced. For example, the addition of a 100pF capacitor between pin 7 (OSC) and V+ will lower the oscillator frequency to 1kHz from its nominal frequency of 10kHz (a multiple of 10), and thereby necessitate a corresponding increase in the value of C<sub>1</sub> and C<sub>2</sub> (from 10mF to 100mF).

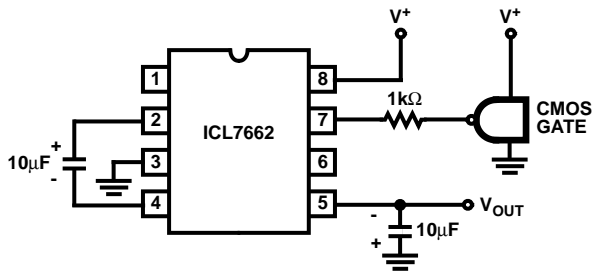

FIGURE 20. EXTERNAL CLOCKING

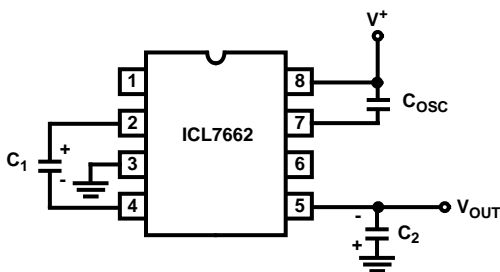

FIGURE 21. LOWERING OSCILLATOR FREQUENCY

**Positive Voltage Doubling**

The ICL7662 may be employed to achieve positive voltage doubling using the circuit shown in Figure 22. In this application, the pump inverter switches of the ICL7662 are used to charge C<sub>1</sub> to a voltage level of V+ -V<sub>F</sub> (where V+ is

the supply voltage and V<sub>F</sub> is the forward voltage drop of diode D<sub>1</sub>). On the transfer cycle, the voltage on C<sub>1</sub> plus the supply voltage (V+) is applied through diode C<sub>2</sub> to capacitor C<sub>2</sub>. The voltage thus created on C<sub>2</sub> becomes (2V+) (2V<sub>F</sub>) or twice the supply voltage minus the combined forward voltage drops of diodes D<sub>1</sub> and D<sub>2</sub>.

The source impedance of the output (V<sub>OUT</sub>) will depend on the output current, but for V+ = 15V and an output current of 10mA it will be approximately 70Ω.

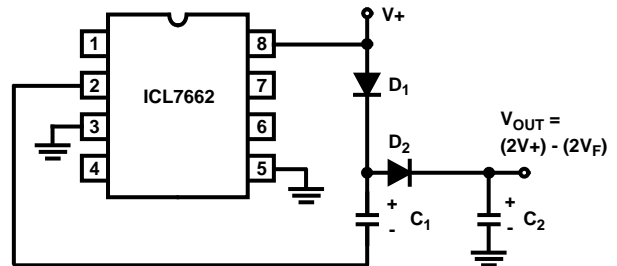

NOTE: D<sub>1</sub> and D<sub>2</sub> can be any suitable diode.

FIGURE 22. POSITIVE VOLTAGE DOUBLER

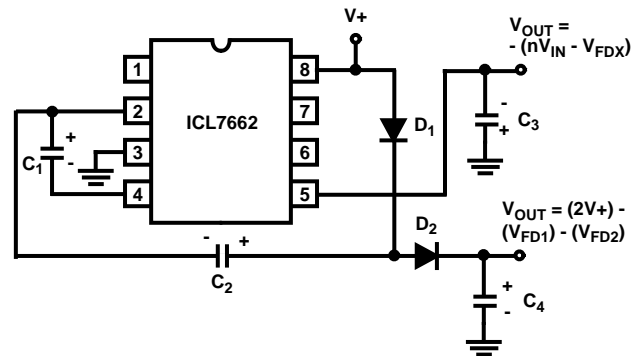

FIGURE 23. COMBINED NEGATIVE CONVERTER AND POSITIVE DOUBLER

**Combined Negative Voltage Conversion and Positive Supply Doubling**

Figure 23 combines the functions shown in Figure 16 and Figure 22 to provide negative voltage conversion and positive voltage doubling simultaneously. This approach would be, for example, suitable for generating +9V and -5V from an existing +5V supply. In this instance capacitors C<sub>1</sub> and C<sub>3</sub> perform the pump and reservoir functions respectively for the generation of the negative voltage, while capacitors C<sub>2</sub> and C<sub>4</sub> are pump and reservoir respectively for the doubled positive voltage. There is a penalty in this configuration which combines both functions, however, in that the source impedances of the generated supplies will be somewhat higher due to the finite impedance of the common charge pump driver at pin 2 of the device.

**Voltage Splitting**

The bidirectional characteristics can also be used to split a higher supply in half, as shown in Figure 24. The combined load will be evenly shared between the two sides and, a high value resistor to the LV pin ensures start-up. Because the switches share the load in parallel, the output impedance is much lower than in the standard circuits, and higher currents can be drawn from the device. By using this circuit, and then the circuit of Figure 19, +30V can be converted (via +15V, and -15V) to a nominal -30V, although with rather high series output resistance (~250Ω).

**Regulated Negative Voltage Supply**

In some cases, the output impedance of the ICL7662 can be a problem, particularly if the load current varies substantially. The circuit of Figure 25 can be used to overcome this by controlling the input voltage, via an ICL7611 low-power CMOS op amp, in such a way as to maintain a nearly constant output voltage. Direct feedback is inadvisable, since the ICL7662s output does not respond instantaneously to a change in input, but only after the switching delay. The circuit shown supplies enough delay to accommodate the ICL7662, while maintaining adequate feedback. An increase in pump and storage capacitors is desirable, and the values shown provides an output impedance of less than 5Ω to a load of 10mA.

**Other Applications**

Further information on the operation and use of the ICL7662 may be found in A051 "Principles and Applications of the ICL7660 CMOS Voltage Converter".

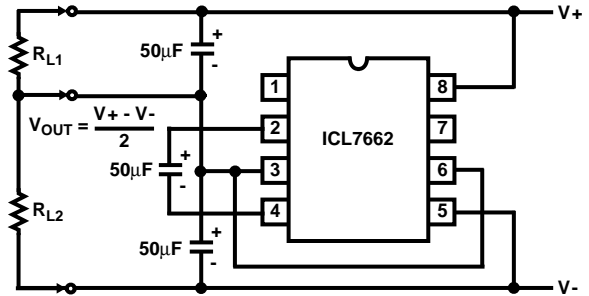

FIGURE 24. SPLITTING A SUPPLY IN HALF

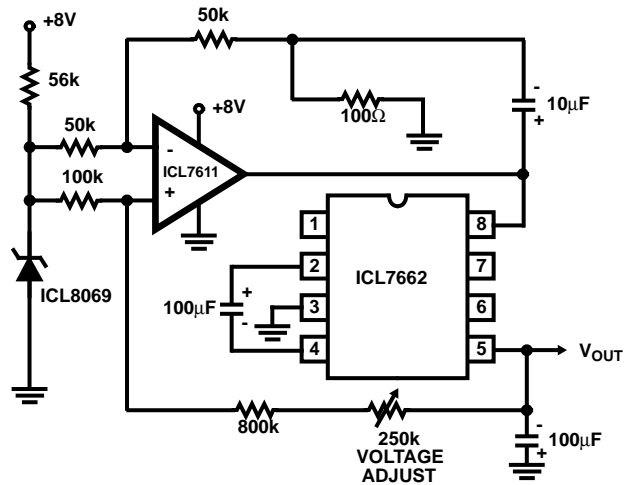

FIGURE 25. REGULATING THE OUTPUT VOLTAGE