



AL128 Data Sheets

Contents

1.0 Features _____	3	9.0 Board Design and Layout Considerations _____	40
2.0 Applications _____	4	9.1 Grounding _____	40
3.0 General Description _____	4	9.2 Power Planes _____	40
4.0 Pinout Diagram _____	5	9.3 Power Supply Decoupling _____	40
5.0 Pin Definition and Description _____	6	9.4 Digital Signal and Clock Interconnect _____	40
6.0 Functional Description _____	12	9.5 Analog Signal Interconnect _____	41
6.1 Input Interface _____	12	9.6 Component Placement _____	41
6.1.1 24-bit RGB _____	13	10.0 Mechanical Drawing _____	42
6.1.2 VAFC _____	13	11.0 Power Consumption _____	44
6.1.3 Feature Connector _____	14		
6.1.4 Sampling (Pixel) Clock _____	14		
6.2 Hardware and Software Control Modes _____	15		
6.3 Video Timing _____	15		
6.4 Supported Resolutions _____	17		
6.5 Flicker Filter _____	18		
6.6 Overscan/Underscan Control _____	18		
6.7 Pan and Position Control _____	18		
6.8 Zoom Feature _____	18		
6.9 Frame Buffer Management _____	19		
6.10 Digital Video Encoder _____	19		
6.11 Push Button Interface/OSD _____	19		
6.12 Memory Control Timing _____	20		
6.13 I²C Programming _____	23		
7.0 Electrical Characteristics _____	26		
7.1 Recommended Operating Conditions _____	26		
7.2 Characteristics _____	26		
8.0 AL128 Register Definition _____	27		
8.1 Index of the Control Registers _____	27		
8.2 Control Register Description _____	28		
8.3 AL128 Plug & Play Hardware Table _____	38		

AL128 Plug and Play VGA to NTSC/PAL Converter

1.0 Features

- Convert non-interlaced VGA or Macintosh video into interlaced TV format (NTSC/PAL)
- Analog RGB output for SCART interface
- Highly integrated design with built-in NTSC/PAL encoder, ADC, DAC and SRAM
- Broadcast TV quality
- High clarity 5-line anti-flicker filter
- 8 levels of sharpness control
- Plug and play with no need for software or micro-controller
- Supports up to full 1024x768 VGA resolution
- Automatically supports scan rate from 50 Hz up to 100 Hz
- Linear vertical and horizontal overscan/underscan control
- Zoom and freeze controls
- Four-touch-button interface with on-screen-menu (on TV) to control all key functions
- Horizontal and vertical position centering control
- Optional digital 24-bit RGB/VAFC interface for best quality
- Power down feature controlled by software or hardware
- Full programmability via I²C interface
- Picture panning control
- Brightness control
- Built-in color bar
- Simultaneous display on PC and TV monitors
- Single 5-volt support
- Thin, small LQFP package for PCMCIA or notebooks. 28x28 PQFP available upon request

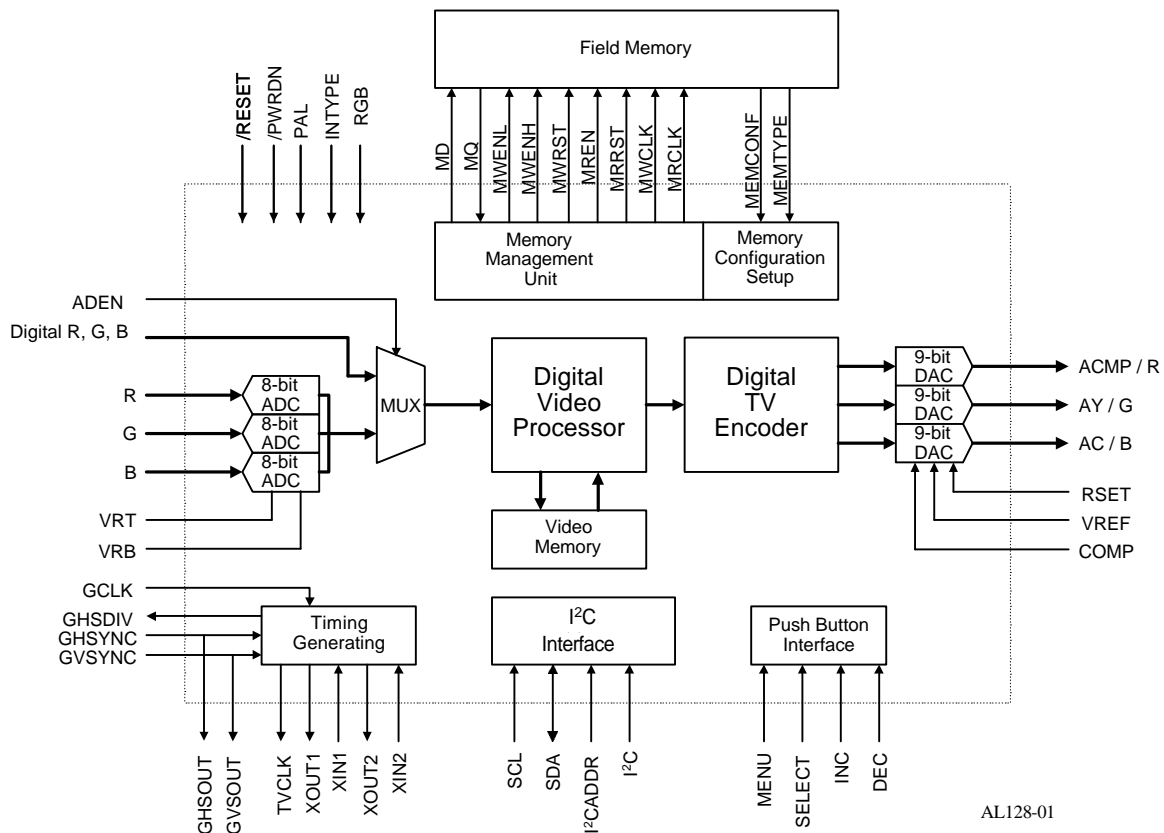

AL128-01

2.0 Applications

PC ready multimedia TV
TV output for laptop, network, entertainment PC
Net browser/set-top box
Internet TV
VGA add-on card with TV output
VGA to TV converter box

3.0 General Description

The AL128 PC to TV scan converter chip accepts graphic data up to 1024x768 resolution from PC and Macintosh graphics controllers and converts it into broadcast-quality NTSC or PAL TV signals. In addition to analog RGB, 24-bit digital RGB data can be input to maintain the best video quality and avoid noise problems. This new chip is pin-to-pin compatible with the AverLogic AL100 but provides analog RGB output for SCART implementation.

An integrated high-quality anti-flicker filter (SmartFilter™) removes the unpleasant flicker caused by the interlaced display of high contrast graphics while maintaining the original clarity and sharpness of informative data such as natural pictures and text.

With 512Kbytes of memory, plug-and-play is achieved by automatically detecting the scan rate and resolution of the incoming graphic signals without the use of software. With less memory than other solutions on the market, high resolution data is processed and stored by using a complex and proprietary buffer management system. No compromise is made at all with video quality by using either compression or sub-sampling algorithms.

The major functions of the AL128 can be accessed using four push buttons combined with the on-screen-menu feature, eliminating the cost of a micro-controller and complex control panel. The superior quality scaling algorithm, which reduces the jagged-edge artifacts from line dropping, can smoothly fit graphics of 640x480 (up to 100 Hz) and 1024x768 (up to 75Hz) resolutions into the visible region of the NTSC or PAL screen. Both horizontal and vertical sizes can be linearly adjusted. Additional features include eight levels of flicker control using 5-line filter, zoom control and picture freeze.

This highly integrated mix-signal chip, packaged in 24mm x 24mm 160-pin LQFP (low quad flat package), is powered by a single 5-volt power supply. Power-down is achieved by using either hardware or software control.

The enhanced features and superior quality make the AL128 very suitable for PC video to TV conversion in PC ready multimedia TV's, scan converter boxes, VGA add-on cards, Web TVs, or network / laptop PCs.

4.0 Pinout Diagram

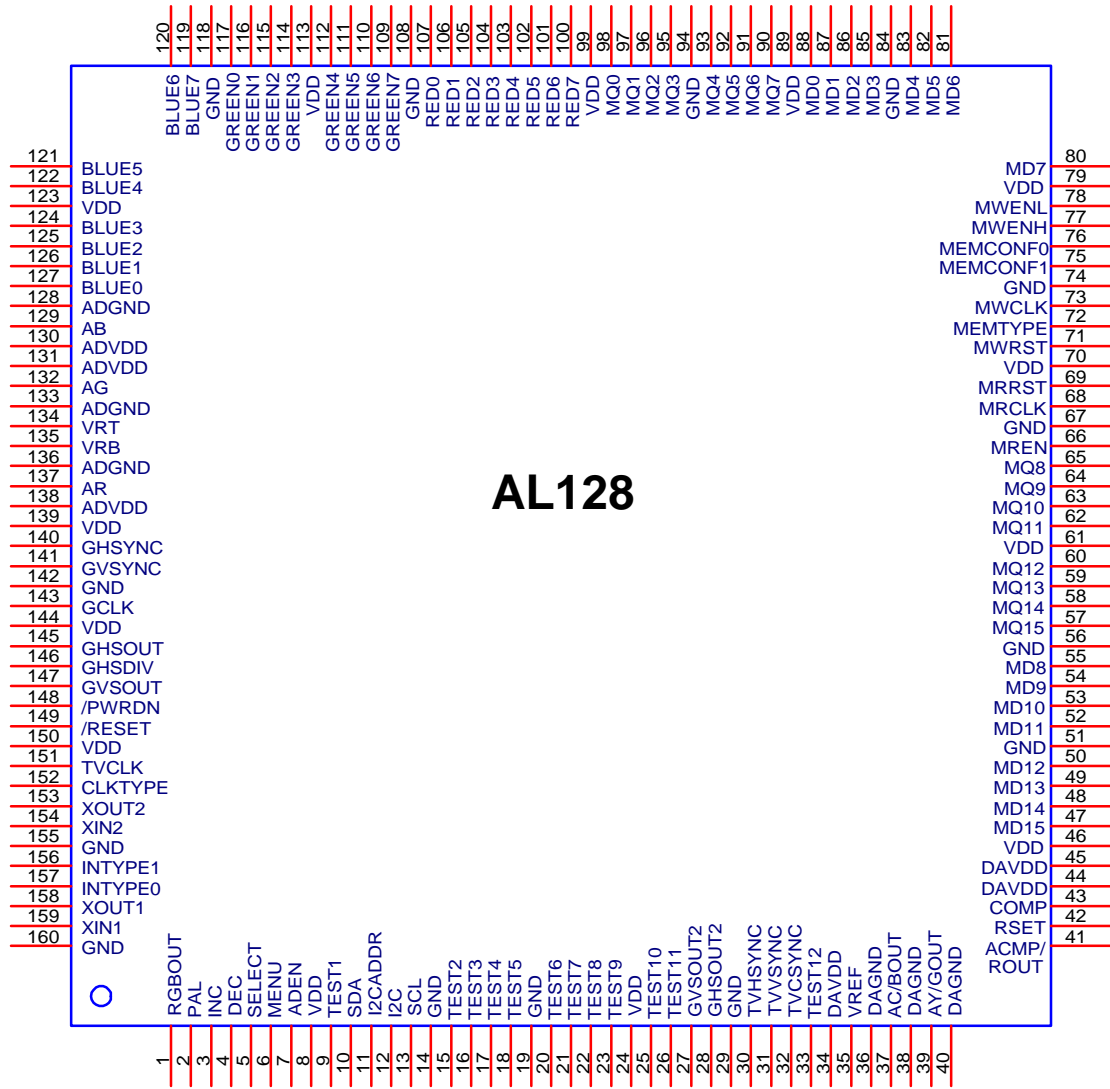

5.0 Pin Definition and Description

Total pin count: 160 pins

Symbol	Type	Pin	Description
/PWRDN	in (CMOSd)	148	Power down enable (active low)
/RESET	in (CMOSd)	149	Reset (active low)
AB	in (0.7 V)	129	Analog Blue
AC/BOUT	out (1/0.7 V p-p)	37	Analog chroma output or analog blue output
ACMP/ROUT	out (1/0.7 V p-p)	41	Analog composite output or analog red output
ADEN	in (CMOSd)	7	Internal ADC enable 0, internal ADC disable 1, internal ADC enable
AG	in (0.7 V)	132	Analog Green
AR	in (0.7 V)	137	Analog Red
AY/GOUT	out (1/0.7 V p-p)	39	Analog luma output or analog green output
BLUE<7:0>	in (CMOSd)	119-122, 124-127	Graphic Blue input data
CLKTYPE	in (CMOSd)	152	Clock Frequency 0 - 28.63636 MHz for NTSC, 35.46895 MHz for PAL 1 - 14.31818 MHz for NTSC, 17.734475 MHz for PAL
COMP	in (0.1uF)	43	DAC Compensation pin, 0.1uF pull-up
DEC	in (CMOSsd)	4	Decrement button
GCLK	in (CMOS)	143	Graphic pixel clock
GHSDIV	out (CMOS)	146	Graphic pixel clock divide by M signal for external PLL circuits.
GHSOUT	out (TTL)	145	Graphic hsync output buffered from external VGA HSYNC
GHSOUT2	out (CMOS)	28	No Connection
GHSYNC	in (CMOSd)	140	Graphic Hsync
GREEN<7:0>	in (CMOSd)	109-112, 114-117	Graphic Green input data

GVSOUT	out (TTL)	147	Graphic vsync output buffered from external VGA VSYNC
GVSOUT2	out (CMOS)	27	Buffered graphic vsync output II.
GVSYNC	in (CMOSd)	141	Graphic VSYNC
I2C	in (CMOSd)	12	I ² C/Vsync programming select 0 - enable VGA sync programming 1 - enable I ² C programming
I2CADDR	in (CMOSd)	11	I ² C sub address 0 - write address = 88, read address = 89 1 - write address = 8C, read address = 8D
INC	in (CMOSsd)	3	Increment button
INTYPE<1:0>	in (CMOSd)	156,157	Graphic input type 00 - 24-bit RGB 01 - reserved 10 - feature connector 11 - VAFC
MD<15:0>	out (CMOS)	47-50, 52-55, 80-83, 85-88	Memory data to input of external field memory.
MEMCONF <1:0>	in (CMOSd)	75,76	External memory configuration 00 – Reserved 01 – One-field memory capture 10 – Two-field memory capture 11 – Reserved
MEMTYPE	in (CMOSd)	72	Memory type 0 - OKI MSM518221/222 1 – AverLogic AL422 or NEC μ PD42280
MENU	in (CMOSsd)	6	Menu button
MQ<15:0>	in (CMOSd)	57-60, 62-65, 90-93, 95-98	Memory data from output of external field memory.
MRCLK	out (CMOS)	68	Memory Read Clock
MREN	out (CMOS)	66	Memory Read Enable
MRRST	out (CMOS)	69	Memory Read Reset
MWCLK	out (CMOS)	73	Memory Write Clock
MWENH	out (CMOS)	77	Memory High Byte Write Enable

MWENL	out (CMOS)	78	Memory Low Byte Write Enable
MWRST	out (CMOS)	71	Memory Write Reset
PAL	in (CMOSd)	2	NTSC/PAL select 0 - NTSC 1 - PAL
RED<7:0>	in (CMOSd)	100-107	Graphic Red input data
RGBOUT	in (CMOSd)	1	RGB/YC Composite output select 0 - ACMP, AY, AC 1 - R, G, B
RSET	in	42	DAC Full scale current adjust, 82 ohm pull-down for S-video and Composite output, 140 ohm pull-down for RGB output.
SCL	in (CMOSsu)	13	I ² C Clock
SDA	in/out (CMOSsu)	10	I ² C Data
SELECT	in (CMOSsd)	5	Select button
TEST1~12	out (CMOS)	9, 15-18, 20-23, 25,26,33	Unused pins for factory test purpose only
TVCSYNC	out (CMOS)	32	TV composite sync
TVHSYNC	out (CMOS)	30	TV horizontal sync
TVVSYNC	out (CMOS)	31	TV vertical sync
TVCLK	out (CMOS)	151	Clock output for graphic chip clock
VRB	in (0 V)	135	ADC Bottom Voltage Reference
VREF	in (1.23 V)	35	DAC Voltage Reference Input
VRT	in	134	ADC Top Voltage Reference
XIN1/FIN1	in (CMOS)	159	Crystal Input/External Clock Input 1 for NTSC
XIN2/FIN2	in (CMOS)	154	Crystal Input/External Clock Input 2 for PAL
XOUT1	out (CMOS)	158	Crystal Output 1 for NTSC
XOUT2	out (CMOS)	153	Crystal Output 2 for PAL
Power and Ground			
VDD x 13	5V	8, 24, 46, 61, 70, 79, 89, 99, 113, 123, 139, 144, 150	Digital power

GND x 14		14, 19, 29, 51, 56, 67, 74, 84, 94, 108, 118, 142, 155, 160	Digital ground
ADVDD x 3	5V	130,131,138	ADC power
ADGND x 3		128,133,136	ADC ground
DAVDD x 3	5V	34,44,45	DAC power
DAGND x 3		36,38,40	DAC ground

Remarks:

CMOSd: CMOS with internal pull-down

CMOSsd: CMOS with Schmitt trigger and internal pull-down

CMOSsu: CMOS with Schmitt trigger and internal pull-up

Pin list grouped by functionality

Symbol	Pin Number
Graphic Interface	
BLUE<7:0>	119-122, 124-127
GREEN<7:0>	109-112, 114-117
RED<7:0>	100-107
GHSYNC	140
GVSYNC	141
GCLK	143
GHSDIV	146
GHSOUT	145
GHSOUT2	28
GVSOUT	147
GVSOUT2	27
Field Memory Interface	
MD<15:0>	47-50, 52-55, 80-83, 85-88
MQ<15:0>	57-60, 62-65, 90-93, 95-98
MWENH	77

MWENL	78
MWRST	71
MREN	66
MRRST	69
MWCLK	73
MRCLK	68
TV Output	
ACMP/ROUT	41
AY/GOUT	39
AC/BOUT	37
TVCSYNC	32
TVHSYNC	30
TVVSYNC	31
Clocks	
XIN1/FIN1	159
XOUT1	158
XIN2/FIN2	154
XOUT2	153
TVCLK	151
User Interface	
SCL	13
SDA	10
MENU	6
SELECT	5
INC	3
DEC	4
Mode select Pins	
RGBOUT	1
PAL	2
INTYPE<1:0>	156,157
MEMCONF<1:0>	75,76
I2CADDR	11

I2C	12
MEMTYPE	72
ADEN	7
CLKTYPE	152
/PWRDN	148
/RESET	149
D/A Converters	
COMP	43
VREF	35
RSET	42
DAVDD x 3	34,44,45
DAGND x 3	36,38,40
A/D Converters	
AR	137
AG	132
AB	129
VRT	134
VRB	135
ADVDD x 3	130,131,138
ADGND x 3	128,133,136
Test Pins	
TEST1~12	9, 15-18, 20-23, 25, 26, 33
Digital Power	
VDD x 13	8,24,46,61,70,79,89,99,113,123,139,144,150
GND x 14	14,19,29,51,56,67,74,84,94,108,118,142,155,160

6.0 Functional Description

The AL128 accepts either analog RGB or digital RGB data. The analog RGB data is digitized by three 50MHz 8-bit video A/D converters and is converted into 24-bit digital RGB data. For graphic controllers with standard or proprietary digital RGB output such as a high-color feature connector, VAFC, or flat panel interface, the optional 24-bit digital RGB interface provides a solution for optimal video quality.

The 24-bit digital RGB is passed to the digital processing unit of the chip. This DSP unit performs scan conversion operations and other digital signal processing such as flicker filtering, YUV filtering, scaling and color space conversion in the digital domain. The processed video data is sent to the digital TV encoder for converting into broadcast quality composite and S-video signals or original RGB format, which are in turn converted by three 9-bit D/A converters into analog outputs.

Functions can be controlled by dedicated hardware pins as well as software. The I²C interface provides full software programmability. The aforementioned hardware and software programmability also applies to the power-down feature. Alternatively only four push buttons are required to control the major functions such as sharpness, pan, zoom, brightness, color bar output and position centering without the use of software or microcontroller.

6.1 Input Interface

RGB data and horizontal and vertical sync signals of the VGA controller are used as inputs. Analog RGB data or 24-bit digital RGB data are both supported. The analog R, G, B signals are digitized with three built-in 8-bit A/D converters. The voltage swing of VGA RGB signals is typically 0.7 volts. The VRT and VRB pins set the input voltage references of the A/D converters. When digital RGB data is used as the input, the internal A/D converters can be disabled by setting pin ADEN low, which may significantly reduce the power consumption.

Digital inputs for the AL128 can be either 24-bit RGB 888 or 16-bit RGB 565. RGB 565 can in turn be in VAFC or feature connector format. The INTYPE pins of the AL128 have to be set correctly to match the different applications.

INTYPE <1:0> Pin 156, pin 157	Digital Graphic Input Type
0 0	24-bit RGB
0 1	Reserved
1 0	Feature connector (RGB565)
1 1	VAFC (RGB565)

6.1.1 24-bit RGB

The digital 24-bit RGB can be pin-to-pin wired to RED<7:0>, GREEN<7:0> and BLUE<7:0> of the AL128.

6.1.2 VAFC

The VAFC format (16-bit, RGB565, in 64k high color) carries red signals in D15~D11, green signals in D10~D5, and blue signals in D4~D0.

There are two ways to implement VAFC interface. The first way is to set INTYPE as 11 to accept VAFC format, then input the 16-bit RGB565 (64k high color) to GREEN<7:0> and BLUE<7:0> of the AL128 as follows:

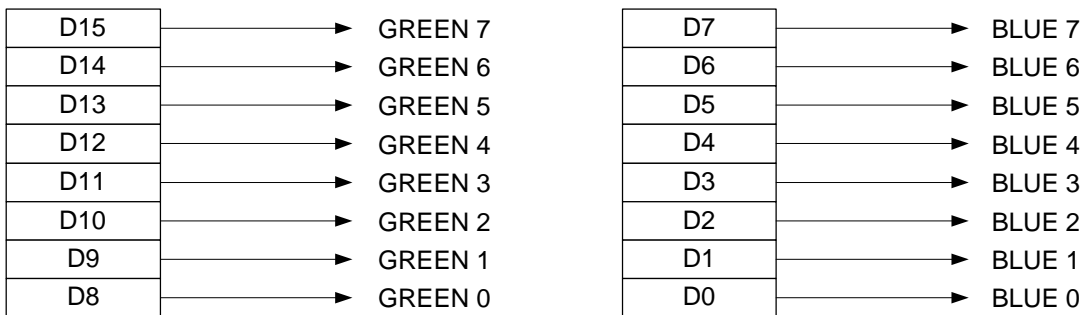

The other way is to keep INTYPE setting as 00 to accept 24-bit RGB888, but connect the inputs to the higher bits of RED<7:0>, GREEN<7:0> and BLUE<7:0> of the AL128 as follows. The unused pins can be grounded.

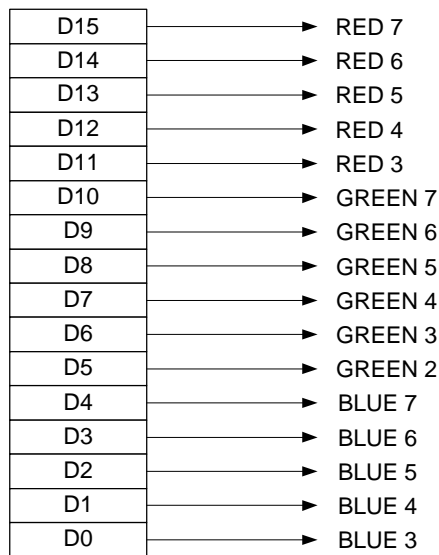

6.1.3 Feature Connector

The definition of the data bits of the feature connector is same as that of the VAFC, i.e., D15~D11 represent red signals. D10~D5 green signals, and D4~D0 blue signals. However, since the feature connector uses 8-bit interface, the two bytes of data must be received within one pixel/graphic clock (GCLK). The solution is: one byte at the rising edge and one byte at the falling edge of GCLK as follows:

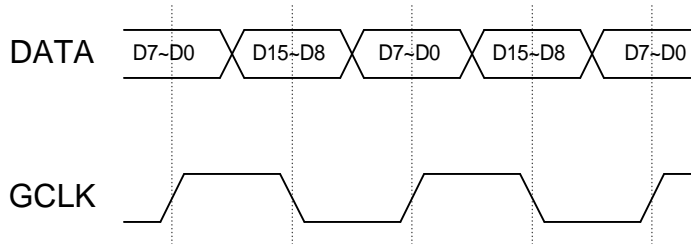

The eight-bit data is wired to BLUE<7:0> of the AL128 as follows:

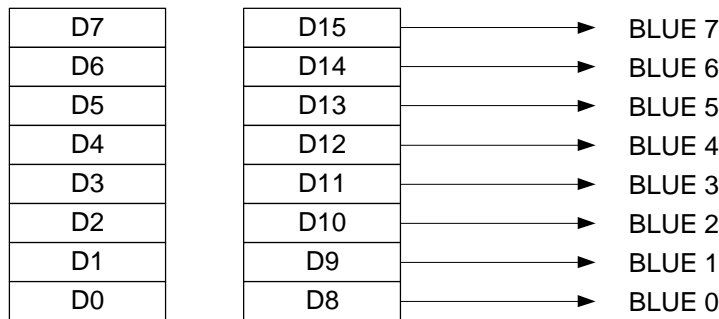

6.1.4 Sampling (Pixel) Clock

The sampling clock for the RGB data can come directly from the graphic pixel clock when this is available. For external box applications where the graphic pixel clock is not available, the clock is recovered from the VGA horizontal sync with an external PLL clock chip such as ICS AV9173. The phase reference signal of the PLL clock chip is generated by the divide-by-M circuitry of the AL128. The AL128 automatically sets the M divider value, which determines the sampling frequency for the A/D converter according to the detected resolution of the incoming graphic data.

6.2 Hardware and Software Control Modes

The AL128 is powered up to a default state depending on the hardware mode-setting pins. Eight of these hardware configuration pins are disabled by setting SoftConfig (bit 4 of register 03h) to one, and configurations are decided by the values of register 0x02, programmable by software.

By default, AL128 major functions can be controlled by On Screen Display Menu (OSDM) push buttons. The registers related to these functions have no effect on those On Screen Display Menu functions unless DisButton (bit 3 of register 03h) is set to one. When this bit is set to one, the external OSDM push buttons are deactivated and those functions are controlled by software programming. The following table lists the functions that can be controlled by either push buttons or software programming, and their corresponding registers.

Function	Register Name	Register Index
Sharpness	VFltMode	33h<2:0>
Zoom	Zoom	20h<1:0>
	ZoomEn	20h<7>
Pan	GinHStartDlt	21h<7:0>
	GinVStartDlt	22h<7:0>
	GinHStZoomDlt	2Bh<6:0>
	GinVStZoomDlt	2Ch<6:0>
Underscan	SoftUdScan	33h<6>
Position	TvHStartDlt	52h<7:0>
	TvVStartDlt	51h<7:0>
Brightness	TvBright	50h<4:3>
Color Bar	ColorBar	50h<1>

Details about the programming can be found in the Register Definition Section.

6.3 Video Timing

Although the AL128 is designed to be plug-&-play, it is programmable to meet special requirements. This is especially advantageous when AL422 is used as field memory since larger memory capacity means higher sampling resolution.

Horizontal capture and display timing is as follows:

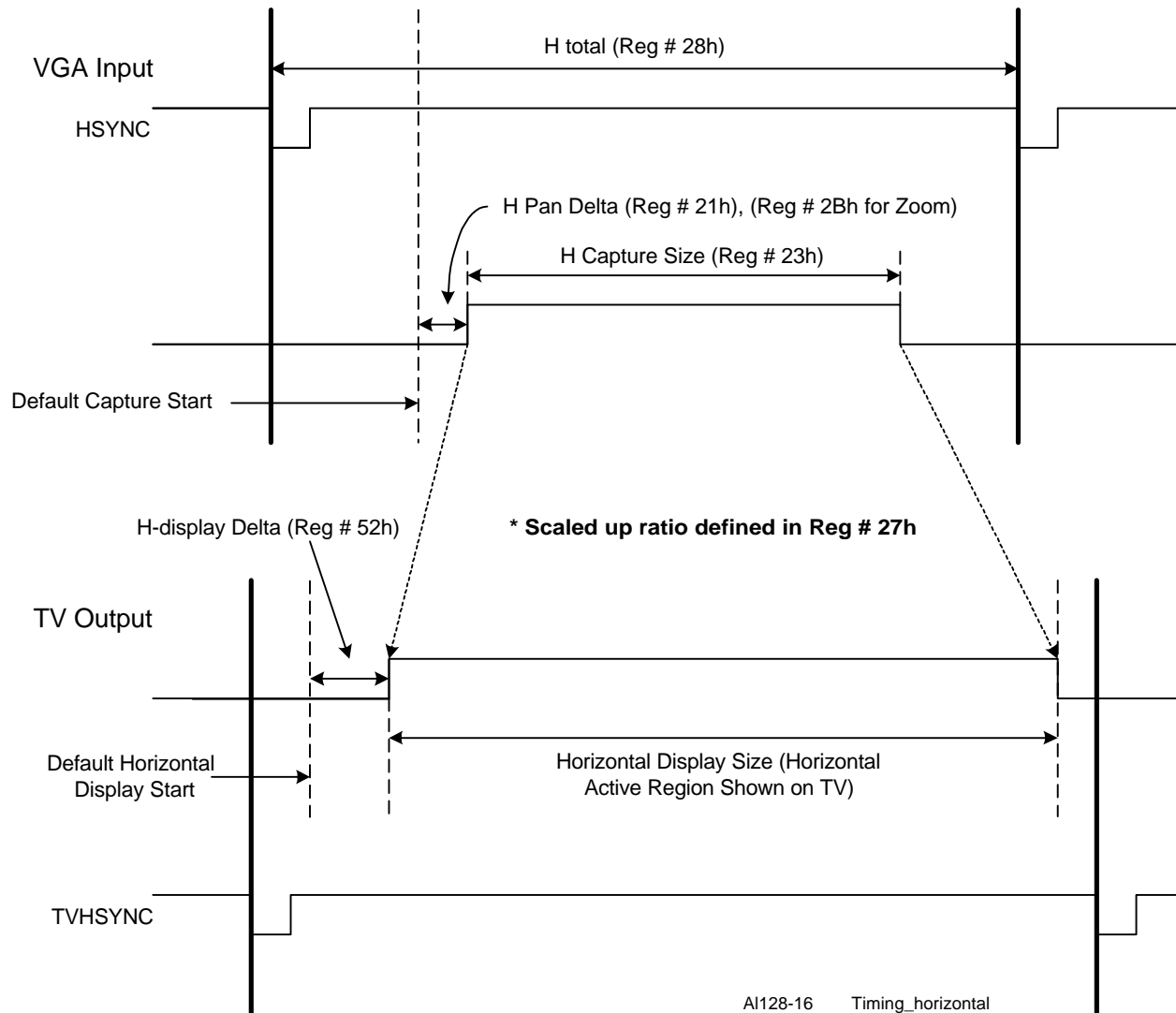

AL128-16 Timing_horizontal

Vertical capture and display timing is as follows:

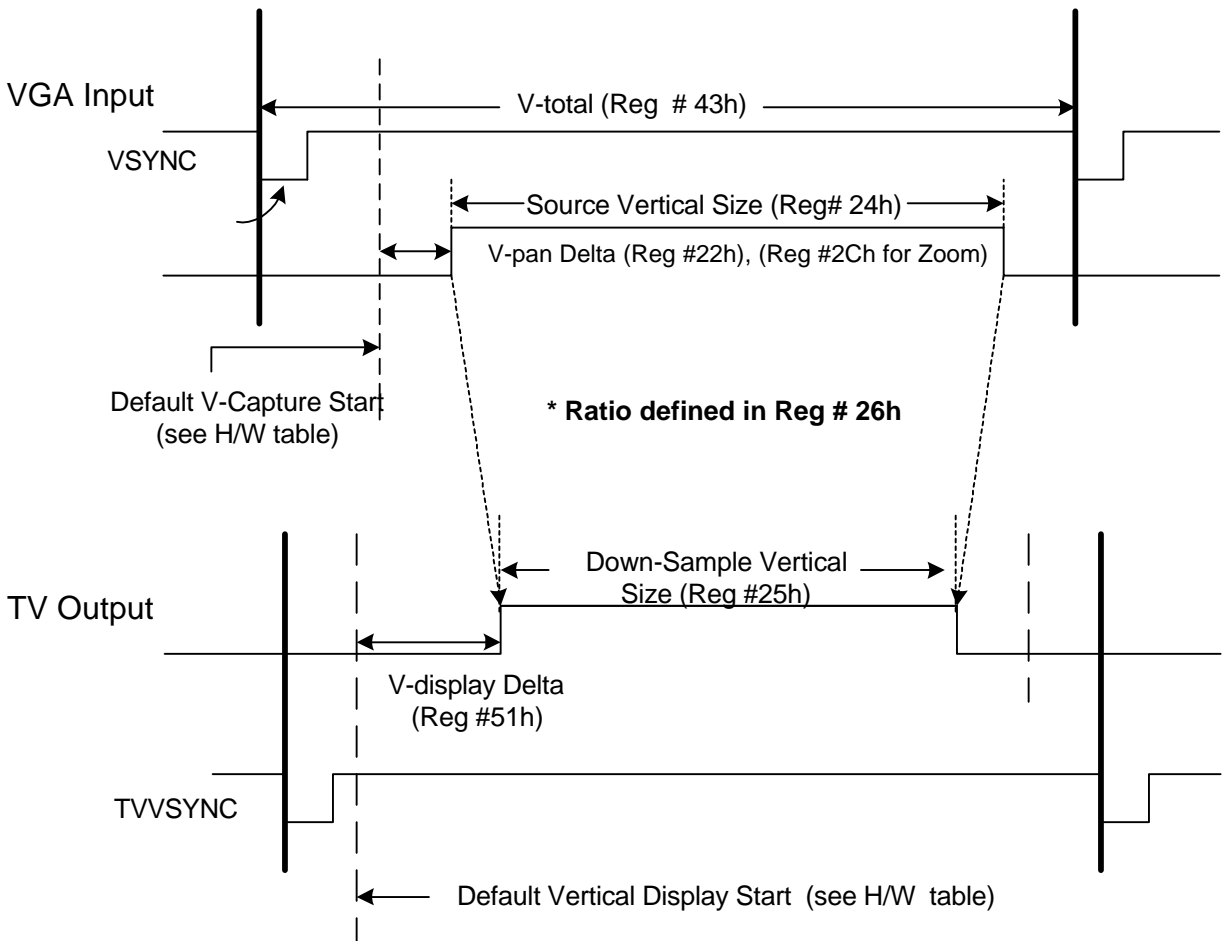

AI128-17 Timing_vertical

Details about register programming can be found in the Register Definition Section. Typical values of the parameters for using AL128 with AL422 can be found in the AL128 Application Notes Supplement.

6.4 Supported Resolutions

The resolutions that are automatically supported without any software are 640x400, 640x480 and 800x600. Other resolutions, such as 1024x768 full screen, are also supported through software programming. Scan rates up to 100 Hz are supported for 640x480 resolution, up to 85 Hz for 800x600 resolution, and up to 75 Hz for 1024x768 resolution.

6.5 Flicker Filter

The AL128 chip performs 5 line flicker filtering to reduce the flicker due to interlaced display of high contrast lines. Eight levels of flicker reduction, as well as sharpness adjustment, are provided to control the picture quality.

Proprietary dynamic filtering (SmartFilter™) is applied to retain the original PC video resolution and sharpness while removing the flickering effect. The hardware intelligently detects which parts of the screen are natural picture and which are text whose clarity needs to be retained. One out of 45 different filters is selected and applied dynamically for each single pixel based on the statistics of its surrounding pixels. The criteria of which filter to choose from is based on a model derived from the ensemble of psychophysical experiments based on human eye responses to the flicker of different picture types.

6.6 Overscan/Underscan Control

Televisions normally overscan, meaning that the border of the picture is outside the visible area of the TV screen. To program the AL128 from Overscan to Underscan, reduce the horizontal display width and vertical display height, and increase the H-display delta and V-display delta. For underscan to overscan, reverse the process. The capture-related registers may need to be programmed for optimization.

The AL128 linearly scales the input picture into the visible part of a TV's screen. Digital filtering techniques are applied to remove the scaling artifacts.

6.7 Pan and Position Control

The panning feature selects the portion of the graphic picture to be displayed on the TV screen. When in zoom mode, the visible screen can be progressively panned to any area of the virtual screen. To pan the display, change the values of H-pan delta (Reg. #21h, #26h) and V-pan delta (Reg. #22h, 2Ch). To pan in zoom mode, #2Bh and #2Ch may also need to be programmed.

Position control is used to center the video on the TV screen. To position the display, change the values of H-display delta (Reg. #52h) and V-display delta (Reg. #51h).

6.8 Zoom Feature

AL128 performs 2x zoom in both horizontal and vertical directions. This can be used with panning, or activated by jumping to any given quadrant via use of the push buttons or software.

To zoom, use register #20h to enable it, and then use #2Bh and #2Ch to position it.

6.9 Frame Buffer Management

Only one half Mbytes of field memory are needed to achieve 24-bit video quality and full resolution scan conversion for either NTSC or PAL. Field memory supported is AverLogic AL422, NEC μ PD42280 and OKI MSM518221/222. With less memory than other solutions on the market, high resolution data is processed and stored by using a complex and proprietary frame buffer management system. There is no compromise with video quality by using either compression or sub-sampling algorithms. Special care is taken in the design so that there is no tearing effect (feathered edge) when playing back moving video sequences such as MPEG I or MPEG II.

To take advantage of the high capacity of the AL422, please review the AL128 Application Notes Supplement for details.

6.10 Digital Video Encoder

The digital video encoder inputs the digital color-space and scan-rate converted video data and output broadcast quality NTSC and PAL signals. The color sub-carrier is generated by a four times over-sampling clock, which greatly simplifies external analog smoothing filter design. Eight times over-sampling mode is also available by software control. The modulated digital signals are converted to analog levels by three 9-bit D/A converters. Composite and S-video signals are output simultaneously. Interlaced RGB output can also be provided.

6.11 Push Button Interface/OSD

The push button interface is used with the on-screen-display menu. There are four buttons: menu, select, increment and decrement. Functions controlled by these push buttons are pan, zoom, position centering, brightness, underscan, color bar and sharpness.

The AL128 EVB provides a user-friendly on-screen control with four push buttons, [Menu], [Select], [<] and [>], for end users to control the major functions of the AL128. There are eight on-screen control functions, which are:

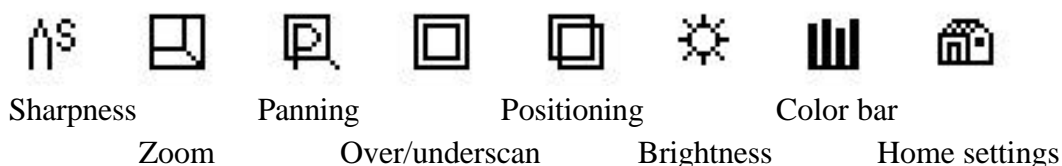

- To pop up the on screen menu, press the [Menu] button.
- To select a control function, use the [<] or [>] button to scroll to it, then press the [Select] button.
- After selecting a control function, use the [Select], [<] or [>] button to adjust the control effects.
- To exit the on screen menu, press [Menu] again.

6.12 Memory Control Timing

The AL128 uses FIFO frame buffers such as the AL422 for scan rate conversion. The input analog RGB signals are digitized at the regenerated GCLK speed. The captured and filtered digital data is written to the FIFO's at a slower speed by using MWENH and MWENL to reduce the bandwidth while the MWCK is maintained at the same speed as GCLK (with a slight phase difference). The enable duty cycle of the MWENH and the MWENL is programmable by controlling register #25h, as long as the captured data volume does not exceed the FIFO capacity. The MWENH controls luma data write enable; the MWENL controls chroma data write enable. After the whole frame data is written, the WRRST is applied right before the next input frame is to be captured to reset the write pointer back to zero.

The following drawing shows the graphic sync signals and FIFO control write timing:

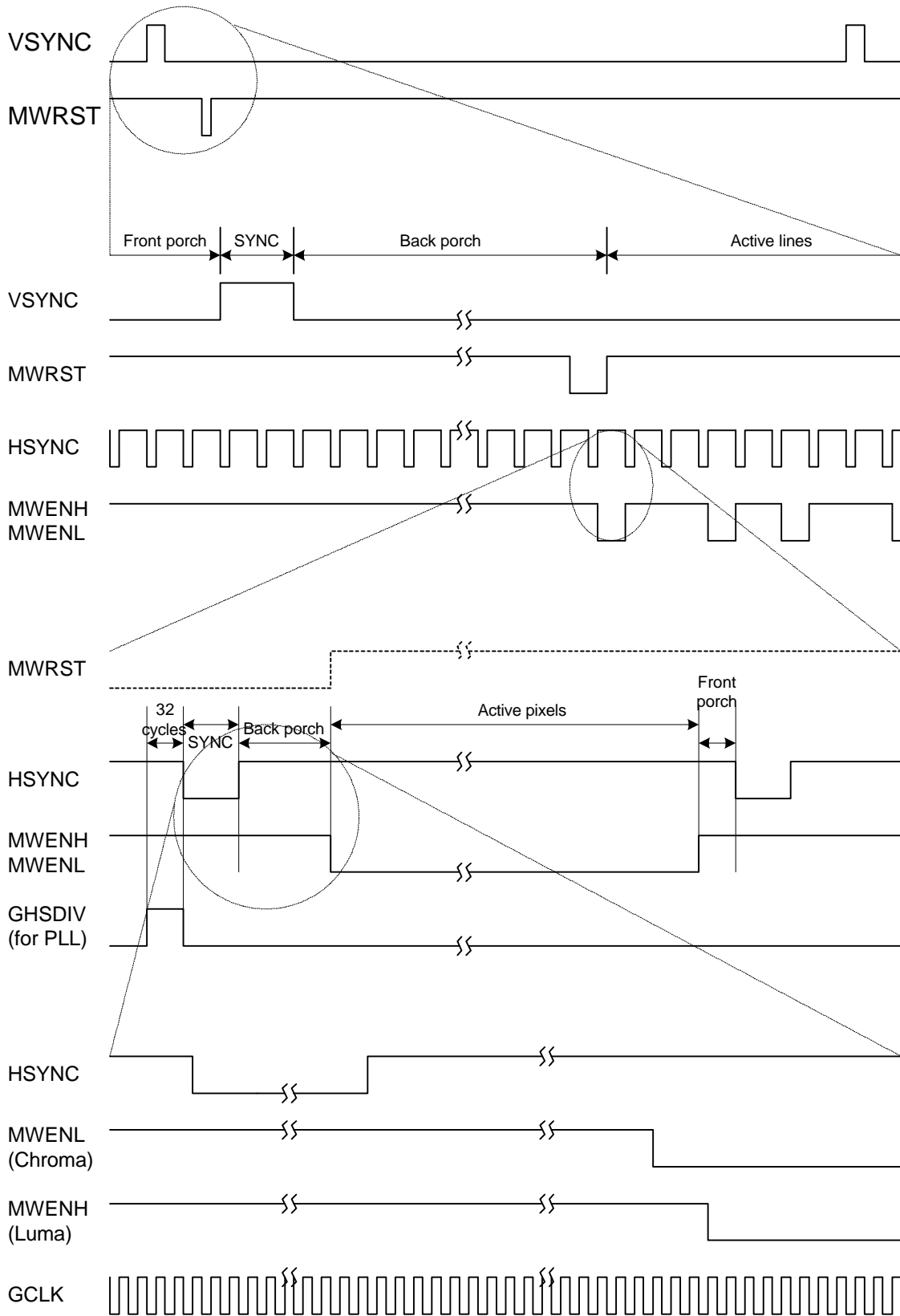

AL128-26 FIFO control VGA timing

The read clock RCLK is either 14.318MHz for NTSC or 17.734MHz for PAL. Not every single pixel of input data is read so that the bandwidth may fit the lower TV resolution, and this is controlled by various enable duty cycles of the REN. PAL has a higher enable duty cycle than NTSC because of its higher resolution. MRRST is applied right before the next valid output field to reset the read pointer back to zero.

The following drawing shows the TV sync signals and FIFO control read timing:

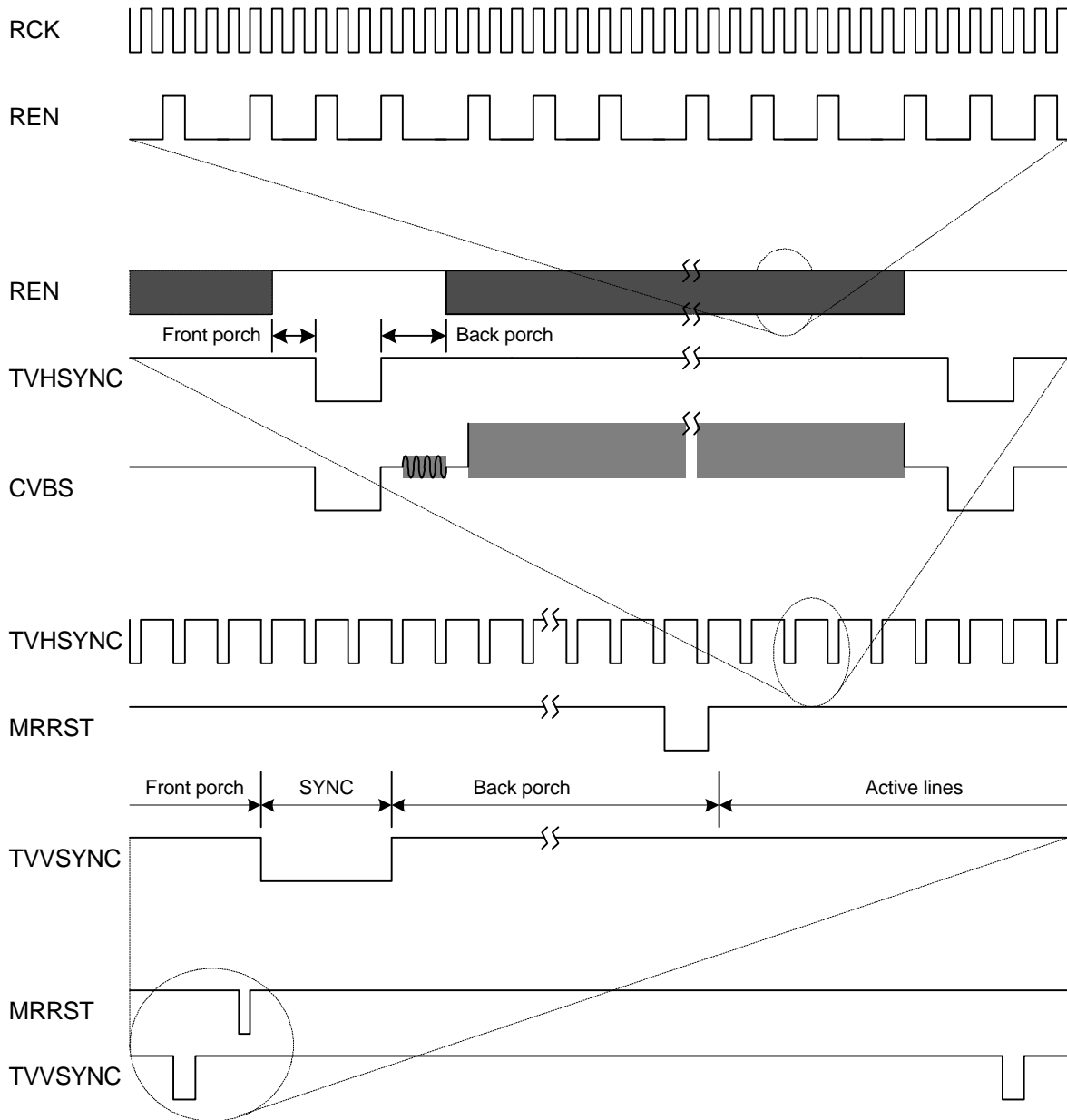

AL128-27 FIFO control TV timing

6.13 I²C Programming

The AL100/110/128 I²C programming interface is slightly different from the Philips standard (same write cycles but different read cycles). The I²C interface consists of the SCL (clock) and SDA (data) signals. Data can be written to or read from the AL100/110/128. For both read and write, each byte is transferred MSB first, and the SDA data bit is valid when the SCL is pulled high.

The read/write command format is as follows:

Write: <S> <Write SA> <A> <Register Index> <A> <Data> <A> <P>

Read: <S> <Read SA> <A> <Register Index> <A> <Data> <NA> <P>

Following are the details:

<S>:

Start signal

SCL SDA

High High

High Low

The Start signal is HIGH to LOW transition on the SDA line when SCL is HIGH.

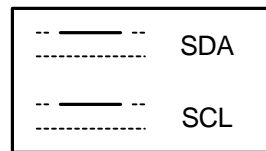

Data bit [1] or NA

<WRITE SA>:

Write Slave Address: 88h or 8Ch

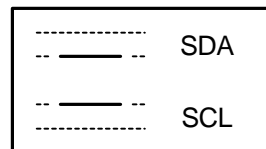

Data bit [0] or A

<READ SA>:

Read Slave Address: 89h or 8Dh

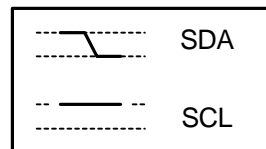

START bit [S]

<REGISTER INDEX>:

Value of the AL100/110/128 register index.

<A>:

Acknowledge stage

The acknowledge-related clock pulse is generated by the host (master). The host releases the SDA line (HIGH) for the AL100/110/128 (slave) to pull down the SDA line during the acknowledge clock pulse.

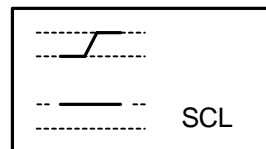

STOP bit [P]

<NA>:

Not Acknowledge stage

The acknowledge-related clock pulse is generated by the host (master). The host releases the SDA line

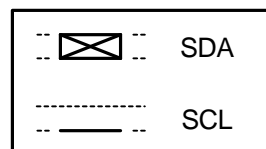

Not significant

(HIGH) during the acknowledge clock pulse, but the AL100/110/128 does not pull it down during this stage.

<DATA>:

Data byte write to or read from the register index.

In read operation, the host must release the SDA line (high) before the first clock pulse is transmitted to the AL100/110/128.

<P>:

Stop signal

SCL SDA

High Low

High High

The Stop signal is LOW to HIGH transition on the SDA line when SCL is HIGH.

Suppose data F0h is to be written to register 0Fh using write slave address 88h, the timing is as follows (same as the Philips standard):

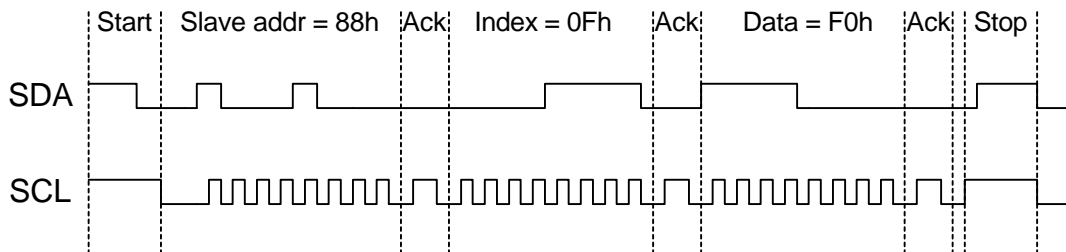

AL128-24 I2C Write timing

Suppose data is to be read from register 55h using read slave address 89h, the timing is as follows:

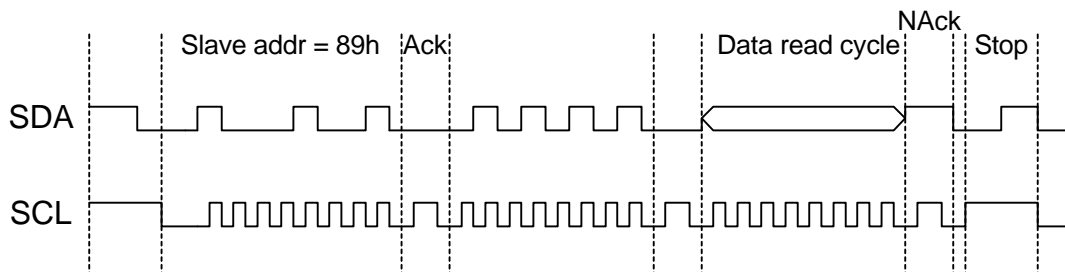

In comparison, reading data from register 55h using slave address 59h with Philips standard would be as follows:

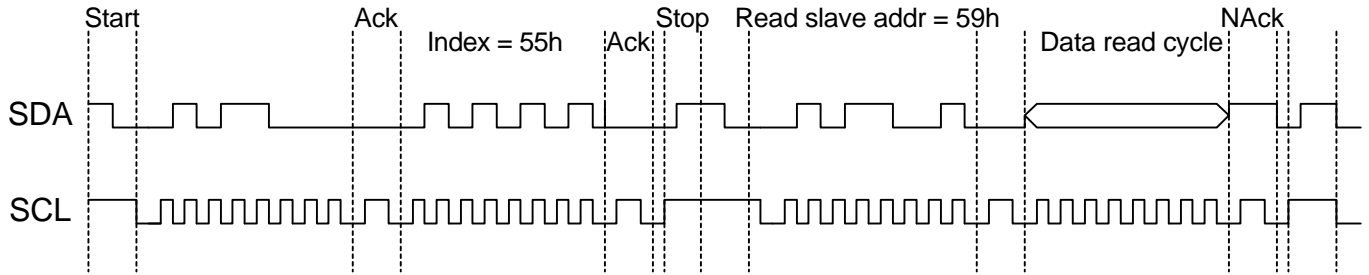

AL250-25 I2C Read timing

7.0 Electrical Characteristics

Parameter	Min	Max	Unit
VDD	+3.8	+5.5	
TAMB Ambient Operating Temperature		+70	

Parameter		Test Conditions	Min	Max	Unit
I _{DD}	Supply current		230	350	mA
P	Power consumption		875	1925	mW
V _{IH}	Hi-level input voltage		0.7VDD	VDD+0.5	V
V _{IL}	Lo-level input voltage		-0.5	+0.8	V
V _{OH}	Hi-level output voltage		2.4	VDD	V
V _{OL}	Lo-level output voltage		-	0.5	V
I _{LI}	Input leakage current		-	1	μA
C _i	Input pin capacitance		-	8	PF
t _{SU}	Input data set-up time		10	-	ns
t _{HD}	Input data hold time		3	-	ns
C _L	Digital output load cap.		15	50	PF
t _{OH}	Output hold time	CL = 15pF	5	-	ns
t _{PD}	Propagation delay	CL = 40pF	-	15	ns
t _r	Output rise time	Vi = 0.6 to 2.6V	3	7	ns
t _f	Output fall time	Vi = 2.6 to 0.6V	3	7	ns

8.0 AL128 Register Definition

8.1 Index of the Control Registers

Register	Index	Function
Configuration		
COMPANYID	00h	Company ID number
REVISION	01h	Revision number
BOARDCONFIG	02h	Board configuration
GENERAL	03h	General control
VERSION	04h	Chip family number
Push Button Interface		
SOFTBUTTON	18h	Software button I
BUTTONSTATUS	19h	Software button II
Graphic Input		
GRAPHCTRL	20h	Graphic control
GINHSTARTDLT	21h	Delta of horizontal start
GINVSTARTDLT	22h	Delta of vertical start
GINCAPHSIZE	23h	Horizontal capture size
GINYSIZE	24h	Source picture vertical size
CAPVSIZE	25h	Destination picture vertical size
CAPVRATIO	26h	Vertical scale ratio
DSPHRATIO	27h	Horizontal scale ratio
PLLDIVIDER	28h	PLL clock divider
GINHSTZOOMDLT	2Bh	Delta of horizontal start in zoom mode
GINVSTZOOMDLT	2Ch	Delta of vertical start in zoom mode
GRAPHDP	33h	Graphic data processing control
	40h	Reserved (for assisting memory control)
Read Only Status Registers		
HWCONFIG	41h	Hardware configuration status
GINHTOTAL	42h	Detected horizontal total

GINVTOTAL	43h	Detected vertical total
SCANRATE	44h	Detected scan rate
TVSTATUS	45h	Vertical position status
Encoder		
ENCODERCTRL	50h	Encoder control
TVVSTARTDLT	51h	Delta of vertical display start
TVHSTARTDLT	52h	Delta of horizontal display start
CAPINV	53h	Capture control
Miscellaneous		
MCAPVRATIO	71h	M of vertical capture ratio value: N/M
NCAPVRATIO	72h	N of vertical capture ratio value: N/M
CHROMABYPASS	73h	Chroma filter bypass control

8.2 Control Register Description

00h: Company ID (R) [COMPANYID]

CompanyId <7:0> Company ID (0x46)

01h: Revision (R) [REVISION]

Revision <7:0> 00000001, Revision ID numbers

02h: Board Configuration (R/W) [BOARDCONFIG]

InType <1:0> Graphic input data format

00 Digital RGB 888

01 Reserved

10 Feature connector

11 VAFC

MemConf <3:2> External memory configuration

00 No external memory used

01 One-field memory capture

Only one field of video data is stored in the field memory. This proprietary design increases the resolution with limited 512kB memory (thus bringing better output quality), but does not work when the input refresh rate is

less than 66Hz for NTSC or 55Hz for PAL, or when freeze control is used.

10 Two-field memory capture

Both odd and even fields of video data are stored in the field memory. When the AL422 is used as the field memory, there is enough capacity at all times so this mode is suggested for programming simplicity.

11 Reserved

MemType	<4>	Memory Type
		0 Oki field memory
		1 NEC field memory
Pal	<5>	PAL/NTSC select
		0 NTSC
		1 PAL
F4sc	<6>	0 Use 8 times SC sampling clock as TV clock
		1 Use 4 times SC sampling clock as TV clock
RgbOut	<7>	0 Composite and S-video output
		1 RGB output

Settings of this register are enabled only when software programming is turned on by writing 18h to Reg.#03h.

03h: General (R/W) [GENERAL]

PwrDown	<0>	Power down the chip if set to 1.
	<2:1>	Reserved
DisButton	<3>	Disable touch button function; use I2C/Vsync interface to program the chip. This bit has to be turned on to enable all the functions marked as ** xxx **.
SoftConfig	<4>	Enable configuration defined by software configuration registers 0x02.
Reserved	<7:5>	

To use software programming properly, read the value of Reg.#41h (hardware configuration) and write it to Reg.#02h. Then write value 18h to Reg.#03h.

04h: Chip Family (R) [VERSION]

Family	<7:0>	00000000, AL100 series
--------	-------	------------------------

Push-Button Interface

18h: Push Button Value (R/W): [SOFTBUTTON]

	<0>	Reserved
	<1>	Reserved
	<3:2>	Reserved
ValuePtr	<7:4>	Number of on-screen-display white rectangle bar, to indicate the level of strength. Works only when Reg.#19h <1> is turned on.

19h: Push Button Status (R/W): [BUTTONSTATUS]

DspMenu	<0>	Enable display of on-screen-display menu icons
DspValue	<1>	Enable display of on-screen-display function icons
DspLeftR	<2>	Enable display of on-screen-display left-right icon
DspUpDn	<3>	Enable display of on-screen-display up-down icon
FuncPtr	<6:4>	Current function icon selected and highlighted. 000: sharpness function icon 001: zoom function icon 010: pan function icon 011: underscan/overscan function icon 100: position function icon 101: brightness function icon 110: color bar function icon 111: home function icon
	<7>	Reserved

Graphic Input Block
20h: Graphics Control Register (R/W) [GRAPHCTRL]

Zoom	<1:0>	zoomed quadrant ** zoom ** 00 Zoom quadrant 0 01 Zoom quadrant 1 10 Zoom quadrant 2 11 Zoom quadrant 3 Meaningful only when ZoomEn = 1. It is recommended not to set these bits when S/W mode is enabled. Instead, use reg#2Bh and reg#2Ch to control the zoomed video visible area.
Vga555	<2>	VGA VAFC/feature connector 555/565 format select 0: 565 format 1: 555 format

	<3>	Reserved
	<4>	Reserved
	<5>	Reserved
	<6>	Reserved
ZoomEn	<7>	Zoom enable ** zoom ** Set to 0 when in basic mode.

21h: Delta of Horizontal Start (R/W) [GINHSTARTDLT]

GinHStartDlt <7:0> Delta of default horizontal capture start position. (unit: 8 pixels) ** X Pan **

This register does not apply to zoom mode.

The actual horizontal capture start position is defined as:

$$(\text{default horizontal capture start position}) + (\text{GinHStartDlt} * 8).$$

The value of GinHStartDlt is signed, and its value is between -128 and 127 .

Please refer to Section 8.3, AL128 Plug & Play Hardware Table for the default horizontal capture start positions.

22h: Delta of Vertical Start (R/W) [GINVSTARTDLT]

GinVStartDlt <7:0> Bit-9 to bit-2 of GinVStartDlt; bit 1,0 are defined in Register 0x26. (Unit: one line) ** Y Pan **

This register does not apply to zoom mode.

The actual vertical capture start position is defined as:

$$(\text{default vertical capture start position}) + (\text{GinVStartDlt} * 4).$$

The value of GinVStartDlt is signed, and its value is between -128 and 127 .

Please refer Section 8.3, AL128 Plug & Play Hardware Table for the default vertical capture start positions.

23h: Horizontal Capture Size (R/W) [GINCAPHSIZE]

GinCapHSize <6:0> Horizontal capture size (Unit: 16 pixels)

SoftCapHSize <7> Override default H capture size value and use GinCapHSize if set to 1.

This register defines the number of pixels of each valid horizontal line, which length is defined by reg#22h (zoom off) or reg#2Ch (zoom on). Only the active horizontal lines are captured, and the range is defined by reg#24h and reg#25h.

The actual horizontal capture size is defined as: $\text{GinCapHSize} * 16$.

The starting capture position is defined by reg#21h (zoom off) or reg#2Bh (zoom on).

The destination total displayed active pixels is defined as:

$$\text{GinCapHSize} * 16 * (\text{scale-up ratio defined in reg\#27h})$$

Please also refer to Section 6.3 Video Timing for better understanding.

Make sure that:

$(\text{GinCapHSize} * 16) \leq 800$ (AL100/128 built-in line buffer size)

$(\text{GinCapHSize} * 16) \leq (\text{reg}\#28\text{h}\langle 6:0 \rangle * 16)$

For one-field memory configuration, the value of $(\text{GinCapHSize} * 16) * (\text{reg}\#25\text{h}\langle 6:0 \rangle * 8) * 2$ must be less or equal to the total field memory size on board.

For two-field memory configuration, the value of $(\text{GinCapHSize} * 16) * (\text{reg}\#25\text{h}\langle 6:0 \rangle * 8) * 2 * 2$ must be less or equal to the total field memory size on board.

24h: Source Vertical Size (R/W) [GINVSIZE]

GinVSize $\langle 6:0 \rangle$ Vertical size of graphic input (unit: 8 lines)

SoftVSize $\langle 7 \rangle$ Override hardware detected V size value and use GinVSize if set to 1.

This register defines the total number of input lines scanned, which starting position is defined by reg#22h (zoom off) or reg#2Bh (zoom on).

The scanned input lines are scaled (down-sampled), filtered and captured into field memory. The destination down-sampled size is defined in reg#25h.

The actual vertical source size is defined as: $\text{GinVSize} * 8$.

The starting position to scan input lines is defined by reg#22h (zoom off) or reg#2Bh (zoom on).

See reg#26h for more description.

Please also refer to Section 6.3 Video Timing for better understanding

25h: Down-sampled Vertical Size (destination) [CAPVSIZE] (R/W)

CapVSize $\langle 6:0 \rangle$ (unit: 8 lines)

CapVSizeEn $\langle 7 \rangle$ enable software vertical size

This register defines the total number of scaled (down-sampled) and filtered video lines captured into the field memory. The actual number is defined as: $\text{CapVSize} * 8$.

For one-field memory configuration, the value of $(\text{reg}\#23\text{h}\langle 6:0 \rangle * 16) * (\text{CapVSize} * 8) * 2$ must be less or equal to the total field memory size on board.

For two-field memory configuration, the value of $(\text{reg}\#23\text{h}\langle 6:0 \rangle * 16) * (\text{CapVSize} * 8) * 2 * 2$ must be less or equal to the total field memory size on board.

See reg. #26h for more description

Please also refer to Section 6.3 Video Timing for better understanding

26h: Y Downscale Ratio [CAPVRATIO] (R/W)

CapVRatio	$\langle 3:0 \rangle$	0000	No line drop
		0001	Drop 3 lines out of 10 lines
		xxxx	(from 0010 to 1110): drop one line for every xxx+1 lines
		1111	vertical scale ratio defined as N/M

N is defined at reg.#72h<5:0>

M is defined at reg.#71h<5:0>

CapVRatioEn	<4>	0: Hardware default vertical scale ratio used for vertical scaling. 1: Software vertical down-scale ratio CapVRatio used.
	<5>	Reserved
GinVStartDlt	<7:6>	bit 1,0 of 10-bit GinVStartDlt. Used with Reg 0x22

The relationship between registers #24h, #25h and #26h is that Reg. #25h<6:0> approximately equals to Reg. #24h<6:0> * (Vertical scale ratio define in Reg. #26h)
Please also refer to Section 6.3 Video Timing for better understanding

27h: Horizontal Scale Ratio [DSPHRATIO] (R/W)

DspHRatio	<5:0>	Software horizontal scale ratio. The value is $((\text{HSRC}/\text{HDST}) \times 256 - 128) / 2$ HSRC is horizontal capture size defined in reg. #23h HDST is horizontal display active size. The default overscan HDST for NTSC is 752; PAL is 954 The default underscan HDST for NTSC is 656; PAL is 800 The pixel total for 910x525 for NTSC, 1126x615 for PAL The suggested HDST in zoom mode is 736~836 (NTSC) and 800~1203 (PAL). Please review the S.5.2 and S.5.3 sections of the AL128 Application Notes (and find the DspH value in different input modes) for details
HscaleEn	<6>	0: Use default hardware horizontal scale ratio. 1: Use DspHRatio and SoftNoScale to control horizontal scale ratio.
SoftNoScale	<7>	turned on when horizontal scaling ratio is 1:1. Don't care if bit<6> = 0.

The AL100 series perform horizontal up-scaling only. For down-scaling, reduce capture size instead by programming Reg.#28h.

The destination total displayed active pixels is defined as:

$$\text{Reg\#23h\<6:0\> * 16 * (\text{HDST}/\text{HSRC})$$

Please also refer to Section 6.3 Video Timing for better understanding.

28h: Graphic Clock PLL Divider (R/W) [PLLDIVIDER]

PlIDiv	<6:0>	PLL divider number (Unit: 16 pixels)
PlIDivEn	<7>	PLL divide number enable 0 Use default hardware divider value. 1 Use PlIDiv registers for the PLL divider number.

This register defines the horizontal total sampled pixels between 2 continuous input horizontal sync. The actual number is defined as: $PIIDiv * 16$

Make sure that the value of $(\text{Graphic Clock PLL divider}) * (\text{Detected Vertical Total}) * (\text{Detected Scan Rate})$ does not exceed the maximum speed of the field memory used, e.g., $PIIDiv * 16 * GinVTotal * 4 * VGArr \leq 56\text{MHz}$ for AL422

$PIIDiv$, $GinVTotal$ and $VGArr$ are defined by registers 28h, 43h and 44h respectively.

2Bh: Delta of Horizontal Start in Zoom Mode (R/W) [GINHSTZOOMDLT]

GinHStZoomDlt <6:0> (unit: 8 pixels) ** X Pan (in zoom mode) **
<7> Reserved

This does not apply to non-zoom mode.

The actual horizontal capture start position is defined as:

$(\text{default horizontal capture start position}) + (\text{GinHStZoomDlt} * 8)$.

The value of $GinHStZoomDlt$ is signed, and its range is between -64 and 63 .

Please refer to Section 8.3, AL128 Plug & Play Hardware Table for the default horizontal capture start positions.

2Ch: Delta of Vertical Start in Zoom Mode (R/W) [GINVSTZOOMDLT]

GinVStZoomDlt <6:0> (unit: 4 lines) ** Y Pan (in zoom mode) **
<7> Reserved

This does not apply to non-zoom mode.

The actual vertical capture start position is defined as:

$(\text{default vertical capture start position}) + (\text{GinVStZoomDlt} * 4)$.

The value of $GinVStZoomDlt$ is signed, and its range is between -64 and 63 .

Please refer to Section 8.3, AL128 Plug & Play Hardware Table for the default vertical capture start positions.

33h: Graphic Data Processing (R/W) [GRAPHDP]

VFltMode <2:0> Vertical Flicker filter mode select ** Filter modes **

UdScanX <3> H direction only underscan

This only reply to H/W default mode. For S/W mode, please use reg#28h and reg#23h to control the horizontal sampling and set this bit to 0

<4> Reserved

<5> Reserved

SoftUdScan <6> 1: Underscan; 0: Overscan. To disable the hardware default settings of the underscan mode, program this bit as 0.

For S/W control, use reg#28h and reg#23h to control the horizontal sampling and set this bit to 0

<7> Reserved

40h: Reserved (R/W)

Reserved for assisting memory control, works only when MemConf is set as two-field memory capture. To be turned on only when there is memory I/O timing conflict. Suggested value is 81h for 1024x768 input / overcan PAL output, and 00h for other modes.

Status Read Only Registers
41h: Hardware Configuration (R only) [HWCONFIG]

InType	<1:0>	Graphic input data format 00 Digital RGB 888 01 Reserved 10 Feature connector 11 VAFC
MemConf	<3:2>	External memory configuration 00 No external memory used 01 One-field memory capture See reg#02h for more information 10 Two-field memory capture See reg#02h for more information 11 Reserved
MemType	<4>	Memory Type 0 Oki field memory 1 AverLogic AL422, NEC or Panasonic field memory
Pal	<5>	PAL/NTSC select 0 NTSC 1 PAL
F4sc	<6>	0 Use 8 times SC sampling clock as TV clock 1 Use 4 times SC sampling clock as TV clock
RgbOut	<7>	0 Composite and S-video output 1 RGB output

42h: Detected Horizontal Total (R only) [GINHTOTAL]

GinHTotal <7:0> Detected horizontal total (Unit: 8 pixels)
For input resolution of 640x480 or 800x600, the value of (GinHTotal * 8) equals to (reg#28h<6:0> * 16). For higher input resolution, PlIDiv needs to be lower than the Detected Horizontal Total so as not to exceed the speed limit of the field memory.

43h: Detected Vertical Total (R only) [GINVTOTAL]

GinVTotal <7:0> Detected vertical total (Unit: 4 lines)

This value can also be used to determine the input resolution:

Detected vertical total	Estimated Input Resolution
<480	720 x 400 (DOS mode)
481~600	640 x 480 (VGA)
601~768	800 x 600 (SVGA)
>769	1024 x 768 (XGA)

44h: Detected Scan Rate (R only) [SCANRATE]

ScanPeriod <6:0> Total number of TV lines counted during an input VGA frame period, in unit of 4 lines.

GinVsync <7> 1 if graphic vsync is active

To determine the VGA refresh rate (VGArr):

 For NTSC: $VGArr = (525 / (\text{Reg.}\#44h\langle 6:0 \rangle)) * 59.94 / 8$

 For PAL: $VGArr = (625 / (\text{Reg.}\#44h\langle 6:0 \rangle)) * 50 / 8$
45h: Vertical Postion Status (R only) [TVSTATUS]

GinData <2:0> Green0, blue1, blue0 pins, reserved as input ports when these hardware pins are not used for digital input.

I2cP <3> I2C pin

I2cP <4> I2C address select pin

TvBlank <5> TV blanking signal

TvField <6> Odd/even field

0 Even field

1 Odd field

TvVsync <7> 1 if TV Vsync is active

Encoder Output Block
50h: Encoder Control: (R/W) [ENCODERCTRL]

Reserved <0>

ColorBar <1> Color bar enable ** Color bar **

BW <2> Make TV output Black and white

TvBright <4:3> TV brightness control ** Brightness **

Filter2 <5> Turned on only for TV without comb filter

<7:6> Reserved

51h: Delta of Vertical Display Start Line (R/W) [TVVSTARTDLT]

TvVStartDlt <7:0> Delta of vertical start line No. (unit: 4 lines) ** Y position
**

The actual vertical display start position is defined as:

(default vertical display start position) + (TvVStartDlt * 4).

The value of TvVStartDlt is signed, and its range is between -128 and 127.

Please refer to Section 8.3, AL128 Plug & Play Hardware Table for the default vertical display start positions.

52h: Delta of Horizontal Display Start Position (R/W) [TVHSTARTDLT]

TvHStartDlt <7:0> Delta of horizontal display start pixel No. (unit: 8 pixels)
** X position **

The actual horizontal display start position is defined as:

(default horizontal display start position) + (TvHStartDlt * 8).

The value of TvHStartDlt is signed, and its value is between -128 and 127.

Please refer to Section 8.3, AL128 Plug & Play Hardware Table for the default horizontal display start positions.

53h: Overrun Test Register (R/W) [CAPINV]

Freeze <0> Freeze the picture, use only two-field memory configuration mode.
<7:1> Reserved

Miscellaneous Control Block

70h: Reserved (R/W)

When <7:5> = 101, pin TEST6 (the internal LUMA<3>) works as hde signal (horizontal data enable input), pin TEST7 (the internal LUMA<2>) works as vde signal (vertical data enable output).

71h: Vertical Capture Ratio M Control: (R/W) [MCAPVRATIO]

M <5:0>

72h: Vertical Capture Ratio M Control: (R/W) [MCAPVRATIO]

N <5:0>

73h: Chroma Filter Bypass Control: (R/W) [CHROMABYPASS]

NoCFilt <3> Chroma filter bypass control; enhance S-video color resolution only when composite output is not used.

0 disabled

1 enabled

UvFlip <2> Flip UV

8.3 AL128 Plug & Play Hardware Table

	NTSC		PAL	
	Underscan	Overscan	Underscan	Overscan
640x400 (DOS)	CapH: 648 CapV: 404->404 CapHST: 136 CapVST: 28 DspH: 648->648 DspV: 404 DspHST: 176 DspVST: 74 Hpll: 800	Same as NTSC underscan defined left	CapH: 648 CapV: 404->404 CapHST: 136 CapVST: 28 DspH: 648->648 DspV: 404 DspHST: 288 DspVST: 136 Hpll: 800	Same as PAL underscan defined left
640x480 reg.#02h<3> = 0 or VGA refresh rate: NTSC: >= 66 Hz PAL: >= 56 Hz	CapH: 656 CapV: 480->420 CapHST: 160 CapVST: 20 DspH: 656->656 DspV: 420 DspHST: 152 DspVST: 68 Hpll: 832	CapH: 656 CapV: 480->480 CapHST: 160 CapVST: 20 DspH: 656->752 DspV: 480 DspHST: 136 DspVST: 32 Hpll: 832	CapH: 656 CapV: 480->480 CapHST: 160 CapVST: 20 DspH: 656->656 DspV: 480 DspHST: 288 DspVST: 96 Hpll: 832	Same as PAL underscan defined left
640x480 reg.#02h<3> = 1 or VGA refresh rate: NTSC: < 66 Hz PAL: < 56 Hz	CapH: 512 CapV: 480->420 CapHST: 120 CapVST: 20 DspH: 512->656 DspV: 420 DspHST: 152 DspVST: 68 Hpll: 640	CapH: 512 CapV: 480->480 CapHST: 120 CapVST: 20 DspH: 512->752 DspV: 480 DspHST: 136 DspVST: 32 Hpll: 640	CapH: 512 CapV: 480->480 CapHST: 120 CapVST: 20 DspH: 512->656 DspV: 480 DspHST: 288 DspVST: 96 Hpll: 640	Same as PAL underscan defined left

800x600 reg.#02h<3> = 0 or VGA refresh rate: NTSC: >= 66 Hz PAL: >= 56 Hz	CapH: 656 CapV: 600->420 CapHST: 160 CapVST: 28 DspH: 656->656 DspV: 420 DspHST: 152 DspVST: 68 Hpll: 832	CapH: 656 CapV: 600->480 CapHST: 160 CapVST: 28 DspH: 656->752 DspV: 480 DspHST: 136 DspVST: 32 Hpll: 832	CapH: 800 CapV: 600->500 CapHST: 200 CapVST: 28 DspH: 800->800 DspV: 500 DspHST: 224 DspVST: 84 Hpll: 1024	CapH: 800 CapV: 576->576 CapHST: 200 CapVST: 28 DspH: 800->928 DspV: 576 DspHST: 152 DspVST: 24 Hpll: 1024
800x600 reg.#02h<3> = 1 or VGA refresh rate: NTSC: < 66 Hz PAL: < 56 Hz	CapH: 512 CapV: 600->420 CapHST: 120 CapVST: 28 DspH: 512->656 DspV: 420 DspHST: 152 DspVST: 68 Hpll: 640	CapH: 512 CapV: 600->480 CapHST: 120 CapVST: 28 DspH: 512->752 DspV: 480 DspHST: 136 DspVST: 32 Hpll: 640	CapH: 656 CapV: 600->500 CapHST: 160 CapVST: 28 DspH: 656->800 DspV: 500 DspHST: 224 DspVST: 84 Hpll: 832	CapH: 656 CapV: 576->576 CapHST: 160 CapVST: 28 DspH: 656->928 DspV: 576 DspHST: 152 DspVST: 24 Hpll: 832

Remarks:
CapH: Horizontal Capture Width

CapHST: Horizontal Capture Start

DspH: Horizontal Display Width

DspHST: Horizontal Display Start

Hpll: Horizontal Total

->: scaled to

CapV: Vertical Capture Height

CapVST: Vertical Capture Start

DspV: Vertical Display Height

DspVST: Vertical Display Start

9.0 Board Design and Layout Considerations

The AL128 is a highly integrated mixed-signal IC. It contains both precision analog and high speed digital circuitry. Special care needs to be taken in order to maintain the best video quality. Noise coupling from digital circuits to analog circuits may result in poor video quality. Therefore, the layout should be optimized for lowest noise on the power and ground planes by shielding the digital circuitry and providing good decoupling.

It is recommended to place the AL128 chip close to the graphic and video input/output connectors.

9.1 Grounding

Analog and digital circuits are separated within the AL128 chip. To minimize system noise and prevent digital system noise from entering the analog portion, a common ground plane for all devices, including the AL128, is recommended. All the connections to the ground plane should have very short lead. The ground plane should be solid, not cross-hatched.

9.2 Power Planes

The analog portion of the AL128 and any associated analog circuitry should have their own power plane, referred to as the analog power plane (AVDD). The analog power plane should be connected to the digital power plane (DVDD) at a single point through a low resistance ferrite bead. The D/A conversion circuitry within the AL128 uses the DVDD power.

The digital power plane should provide power to all digital logic on the PC board, and the analog power plane should provide power to all of the AL128 analog power pins and relevant analog circuitry.

The digital power plane should not be placed under the AL128 chip, the voltage references or other analog circuitry. Capacitive coupling of digital power supply noise from this layer to the AL128 and its related analog circuitry can degrade video output quality.

9.3 Power Supply Decoupling

Power supply connection pins should be individually decoupled. For best results, use 0.1 μ F ceramic chip capacitors. Lead lengths should be minimized. The power pins should be connected to the bypass capacitors before being connected to the power planes. 22 μ F capacitors should also be used between the AL128 power planes and the ground planes to control low-frequency power ripple.

9.4 Digital Signal and Clock Interconnect

Digital signals to the AL128 should be isolated as much as possible from the analog outputs and other analog circuitry. Also, these signals should not overlap the analog power plane. If this is not possible, coupling can be minimized by routing the digital signal at a 90 degree angle across the analog signals.

The high frequency clock reference or crystal should be handled carefully. Jitter and noise on the clock will degrade the video performance. Keep the clock paths to the AL128 as short as possible to reduce noise pickup.

Locate phase locked loop components close to the relevant AL128 pins. Isolate these components from noise.

9.5 Analog Signal Interconnect

The AL128 should be located closely to the output connectors to minimize noise and reflections. Keep the critical analog traces as short and wide as possible.

High frequency digital signals, especially pixel clocks and data signals should never overlap any of the analog signal circuitry and should be kept as far away as possible.

The AL128 should have no inputs left floating. Each of the unused analog input pins should be connected to GND. All of the digital input pins are internally pulled down.

The analog output traces should also not cross the AL128 and VDD power planes to maximize high-frequency power supply rejection.

9.6 Component Placement

The suggested component placement is as follows:

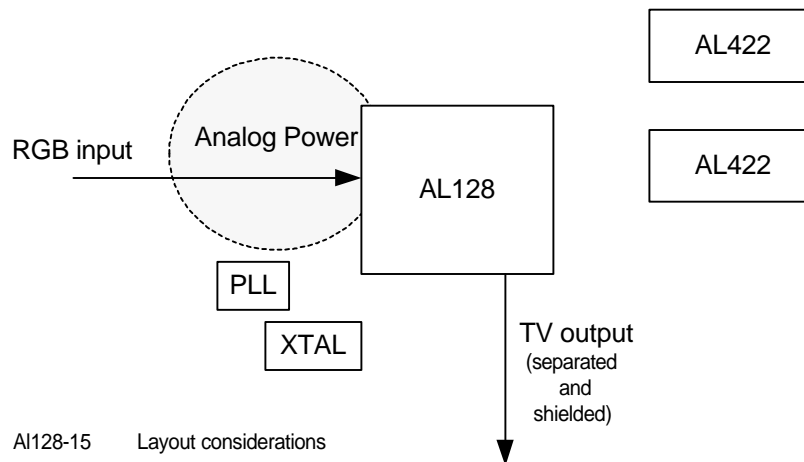

Remarks:

1. PLL crystal/oscillator circuits should be placed at the lower left corner and close to AL128 to avoid noise interference.

2. VGA input and TV output are both analog signals so should be away from high frequency digital signals as much as possible. Use thicker connection such as 20 or 30 mil wires. Output signals should not be too far away from the output connectors and should be shielded properly. Shielding in between the output signals is recommended as well.
3. Analog power should be arranged at the upper left corner of the AL128 only (the output circuits including DAC's share the same power plane with digital power plane so do not need to use analog power). Keep the analog power separated and clean to avoid noise interference.

10.0 Mechanical Drawing

The AL128 is fabricated using CMOS process and packaged in a low profile 24mm x 24mm 160-pin LQFP package. This package type is perfect for PCMCIA or laptop computer applications. Optional 28mm x 28mm PQFP package is also available upon request.

The drawing is provided on the following page.

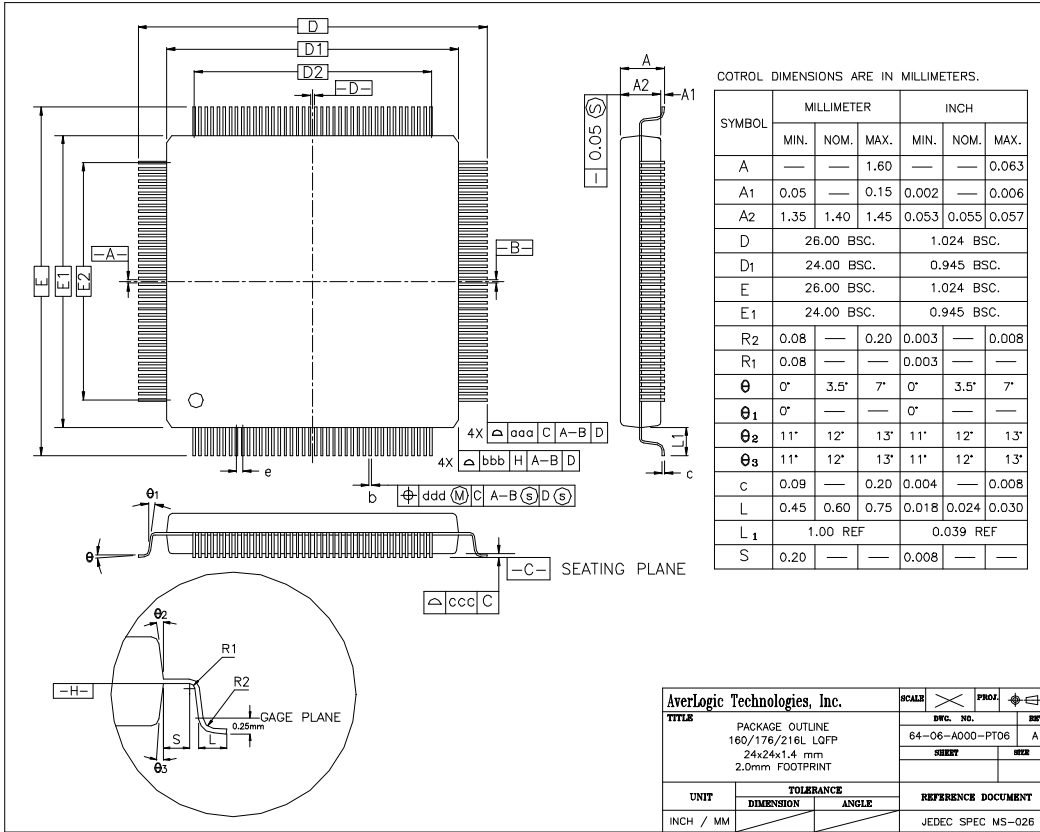

AverLogic Technologies, Inc.		SCALE	PROJ.	REV.
TITLE		DWG. NO.	REV.	
PACKAGE OUTLINE 160/176/216L LQFP 24x24x1.4 mm 2.0mm FOOTPRINT		64-06-A000-PT06	A	
UNIT		REFERENCE DOCUMENT		
INCH / MM		JEDEC SPEC MS-026		

SYMBOL	160L			176L			216L		
	MIN.	NOM.	MAX.	MIN.	NOM.	MAX.	MIN.	NOM.	MAX.
b	0.17	0.20	0.27	0.007	0.008	0.011	0.17	0.20	0.27
e	0.50 BSC.			0.50 BSC.			0.50 BSC.		
D2	19.50			21.50			21.20		
E2	19.50			21.50			21.20		
TOLERANCES OF FORM AND POSITION									
qaa	0.20			0.008			0.20		
bbb	0.20			0.008			0.20		
ccc	0.08			0.003			0.08		
ddd	0.08			0.003			0.07		

- NOTES :
- DIMENSIONS D1 AND E1 DO NOT INCLUDE MOLD PROTRUSION.
ALLOWABLE PROTRUSION IS 0.25mm PER SIDE. D1 AND E1 ARE MAXIMUM PLASTIC BODY SIZE DIMENSIONS INCLUDING MOLD MISMATCH.
 - DIMENSION b DOES NOT INCLUDE DAMBAR PROTRUSION.
ALLOWABLE DAMBAR PROTRUSION SHALL NOT CAUSE THE LEAD WIDTH TO EXCEED THE MAXIMUM b DIMENSION BY MORE THAN 0.08mm.
DAMBAR CAN NOT BE LOCATED ON THE LOWER RADIUS OR THE FOOT. MINIMUM SPACE BETWEEN PROTRUSION AND AN ADJACENT LEAD IS 0.07mm FOR 0.4mm and 0.5mm PITCH PACKAGES.

AverLogic Technologies, Inc.		SCALE	PROJ.	REV.
TITLE		DWG. NO.	REV.	
PACKAGE OUTLINE 160/176/216L LQFP 24x24x1.4 mm 2.0mm FOOTPRINT		64-06-A000-PT06	A	
UNIT		REFERENCE DOCUMENT		
INCH / MM		JEDEC SPEC MS-026		

11.0 Power Consumption

The AL128 works at +5V or +3.3V, but the support of input resolution and refresh rate may be limited at the lower power. For full functionality of the AL128, the power needs to be more than +3.8V. At +3.3V, the AL128 can only support 640x480 resolution up to 85Hz and 800x600 resolution up to 60Hz. The following table shows the current consumption of the AL128 at different supply voltages.

	+5V	+3.8V	+3.3V (800x600 @60Hz)
Normal	330mA	230mA	130mA
Power down	90mA	35mA	10mA

Please be reminded that when lower power supply is used, the pull-down resistance to the RSET pin has to be adjusted to compensate (in both Y/C/Composite mode and RGB mode) accordingly. The lower the supply voltage is, the lower the pull-down resistance has to be. The ideal resistance values can be achieved by adjusting the Y/C/Composite output to be 1V peak-to-peak, or the RGB output to be 0.7V peak-to-peak.

CONTACT INFORMATION

AverLogic Technologies, Inc.
6840 Via Del Oro
Suite 160
San Jose, CA 95119
USA

Tel : 1 408 361-0400
Fax : 1 408 361-0404
E-mail : sales@averlogic.com
URL : <http://www.averlogic.com>