

PV1000 PCI/ISA PROCESSOR MODULE

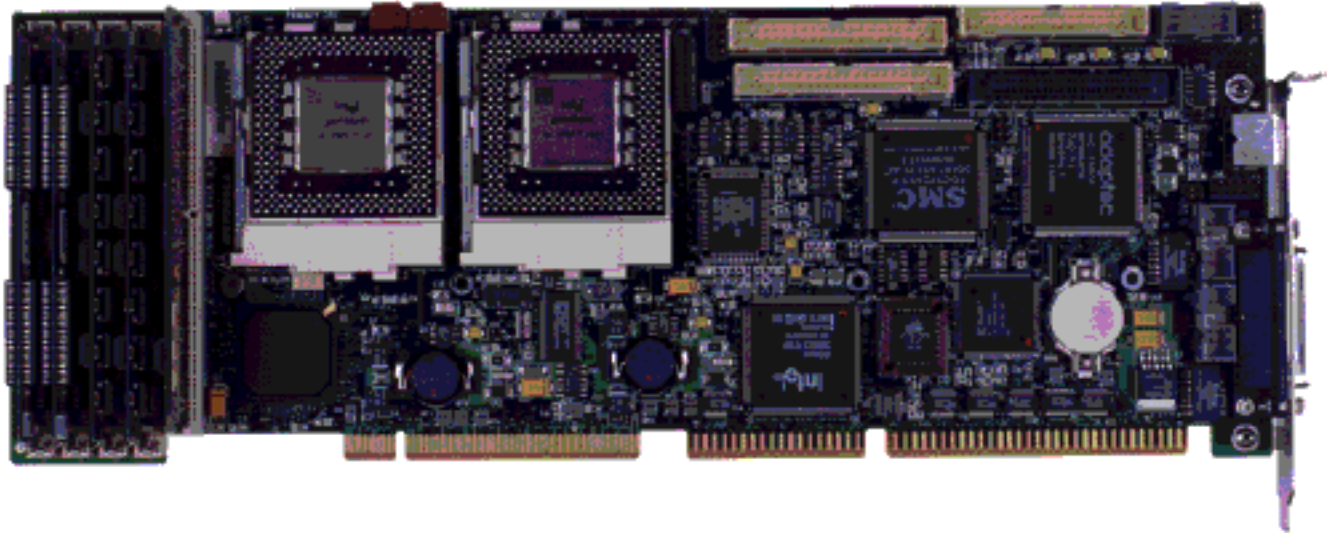

Advantages

Motorola's PV1000 single-board computer provides exceptional, scaleable performance, combining reliable, leading-edge technology and compatibility with either ISA or PICMG® compliant PCI/ISA passive backplanes. Supporting one or two Intel® Pentium® P55C (MMX™) processors with speeds up to 233 MHz, the PV1000 hosts a robust array of I/O including floppy disk and PCI EIDE/SCSI peripheral controllers, serial/parallel ports, and Flash memory. Quite simply, Motorola's PV1000 industrial single-board computer is the price and performance leader for high-reliability, high-maintainability, real-time applications such as telecommunications/CTI, medical and scientific systems, industrial control and monitoring, and data acquisition.

Features

- Single or dual Pentium P55C MMX processors
- Up to 233 MHz
- Intel 430HX Triton chipset
- Up to 512MB EDO memory
- 512KB L2 cache modules
- PCI EIDE and 16-bit Fast/Wide SCSI-2
- PCI 2.1 compliant

PV1000 PCI/ISA Processor Module

Supporting one or two Intel Pentium processors including MMX technology, the PV1000 is 100% compatible with MPspec version 1.1 enabling use with either SMP (Symmetric Multi-Processing) or single processor operating environments. A high-efficiency on-board switching regulator provides up to 12 Amps of 3.3 volt power for the Pentium processors while minimizing power consumption and heat. Superior reliability and data integrity are achieved through high-level integration and support for error correction (ECC) memory using standard EDO SIMMs and 512KB 8ns synchronous pipeline burst L2 cache.

The PV1000 hosts a robust array of I/O including floppy disk and PCI EIDE/SCSI peripheral controllers, serial/parallel ports, and Flash BIOS. ISA bus performance is significantly improved and PCI bus graphics/IDE performance is improved by up to 10% through the use of the Intel 82430HX PCI chipset.

The AMI WINBIOS, in bootable Flash EPROM, supports up to 12 PCI and 20 ISA add-in cards and provides setup utilities for ISA and PCI system configurations and user definable drive parameters. Other features include an alarm micro-controller (voltage, temperature, fan), the high bandwidth of the 132MB/second PCI local bus and serial number in EPROM.

Ordering Information

Part Number	Description
Base SBC	
PV1000-200	Single board computer with 200 MHz Pentium with MMX technology, SCSI, w/o cache, w/o memory
PV1000-233	Single board computer with 233 MHz Pentium with MMX technology, SCSI, w/o cache, w/o memory
Memory Options	
PPXCACHE512	512KB L2 cache
MEM72E-xxx	Extended Data Out DRAM SIMM
Note: xxx = capacity in MB	

The Motorola Commitment

Motorola Computer Group is committed to providing best-in-class embedded computing solutions. The PV1000 reinforces this commitment by providing superior hardware, price performance, and faithfulness to the tenets of open computing: modularity, scalability, portability, and interoperability.

The PV1000 is offered with a five-year limited warranty which reduces the cost of ownership and demonstrates our commitment to quality and reliability of products to our OEM partners.

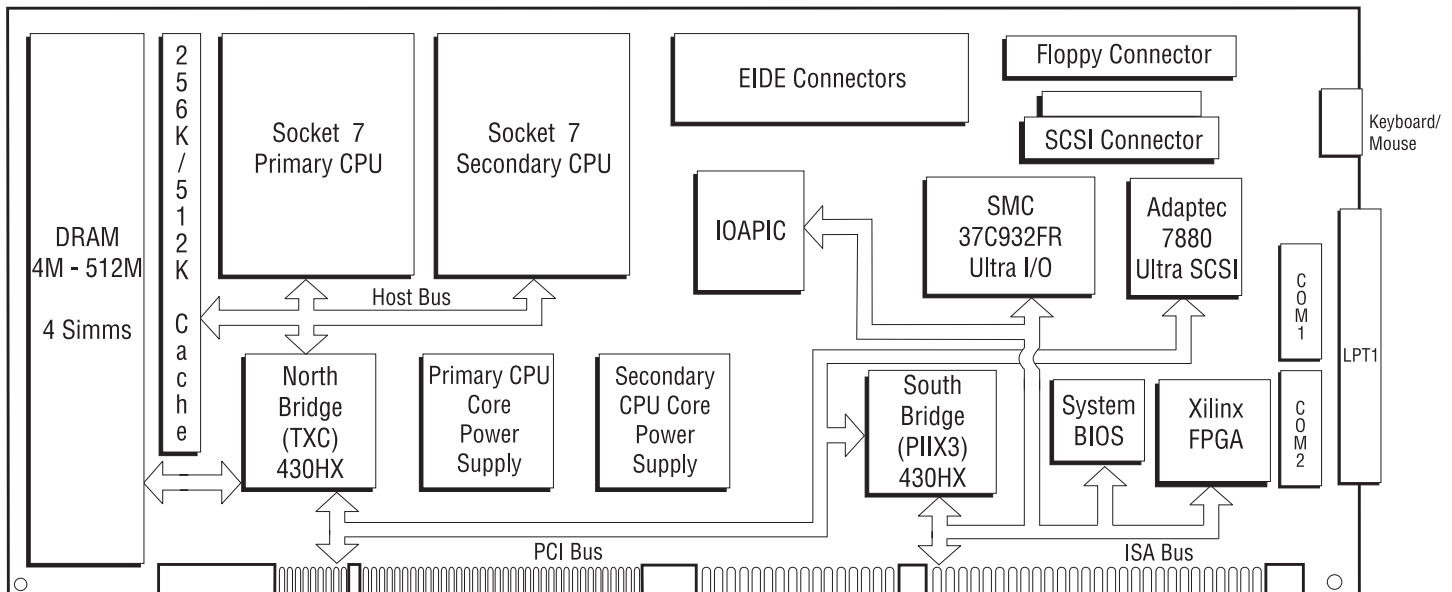

PV1000 Block Diagram

Specifications

PV1000 PCI/ISA Processor Module

Processor

Single or dual 200, 233 MHz Pentium MMX (Socket 7 connector)

Cache

512KB Level 2 write-back (8ns synchronous pipeline burst COAST 3.0 SRAM)

Memory

Sockets: Two banks of two 72-pin latching SIMM sockets
DRAM: Extended Data Out; up to 512MB with 1/2/4/8/16MB x 32, 60ns

Addressing

Real (20-bit) and protected (16-bit on bus access) supported

Bus Interface

PCI/ISA or ISA, PICMG and IBM PC/AT compatible
PCI Bus (120-pin) fully buffered (33/30 MHz)
ISA Bus (98-pin) fully buffered (8.33 MHz); up to 20 slots with 24mA bus drivers

Data Path

CPU Bus: 64-bit
PCI Bus: 32-bit
ISA Bus: 16-bit (ISA bus mastering)

Interrupts

11 edge sensitive and configurable
Four PCI level sensitive, configurable mapped as IRQ 5, 9, 10, 11, or 15 "OR'd," enabling shared on-card and off-card interrupts

DMA Channels

Four 8-bit, three 16-bit; supports scatter/gather, F-Type DMA

I/O

Serial Ports: Two RS-232 (16550) configurable as COM1-4 with RS-422/485 available on COM2 and COM4
Parallel Port: One bi-directional port with all IEEE 1284 protocols supported (compatibility, nibble, byte, EPP, and ECP)
Floppy Disk: Support for two drives (2.88MB support)
EIDE: PCI-EIDE, two drives; includes LBA and PIO mode 0-4 support
SCSI: PCI Ultra fast/wide SCSI-2 (Adaptec 7880, 8-bit fast, 16-bit fast/wide or mixture)

Connectors

EIDE hard disks, floppy disk, and serial ports:	Individual shrouded headers
F/W SCSI-2:	68-pin high-density receptacle
AT keyboard, speaker, disk/power LEDs, reset, lock, alarm:	Combo unshrouded headers
Parallel port:	25-pin D-sub on slot bracket
PS/2 mouse/keyboard:	6-pin mini DIN on slot bracket (Y-cable included)

Clock/calendar

Real-time clock, includes 256-byte CMOS

Mechanical

13.32" x 4.80" (338mm x 122mm); conforms to IEEE P996 PC/AT bus, PCI Rev. 2.1, and PICMG Rev. 2.0 specifications

BIOS Features

AMI WINBIOS, in Flash EPROM
Auto configuration, extended setup, and Plug and Play tables
Diskless, keyboardless, and videoless operation extensions
Programmable bus and I/O speeds, and memory wait states
Support for "memory holes"/ISA bus aliasing, and C000h-DFFFh address blocking
System, video, and SCSI BIOS shadowing
BIOS POST and Setup console redirection to serial port

Supervisory

Software programmable, two-level Watchdog timer (17.8ms to 291sec.) drives interrupt 11, NMI, or system reset
Software readable CPU (2) temperature sensors
Open collector alarm output to 2-pin external alarm relay connector

Power Requirements

Input power:	32W (for single 200 MHz with 512K cache and 32MB DRAM)
+5V	6.0 A (regulated down to 3.3V at CPU)
+12V	0.1 A

Environmental

	Operating	Storage/Transit
Temperature:	0° C to 60° C	-40° C to +70° C
Humidity (NC):	5 to 95% @ 40° C	0 to 95% @ 40° C
Altitude:	15,000 ft. (4,572 m)	50,000 ft. (15,240 m)
Vibration		
Y-axis:	1.5Gs 3-39 Hz, 100-200 Hz; 0.5G 40-99 Hz	
X-axis:	1.5Gs 3-39 Hz; 0.5G 40-200 Hz	
Z-axis:	1.5Gs 3-49 Hz; 0.75G 50-200 Hz	

Demonstrated MTBF

(based on sample testing in accelerated stress environment)
Mean/90% Confidence: 190,509/107,681

Safety

All printed wiring boards (PWBs) are manufactured with a flammability rating of 94V-0 by UL recognized manufacturers.

Electromagnetic Compatibility (EMC)

Intended for use in systems meeting the following regulations:

U.S.: FCC Part 15, Subpart B, Class A
Canada: ICES-003, Class A

This product was tested in a representative system to the following standards:
CE Mark per European EMC Directive 89/336/EEC with Amendments;
Emissions: EN55022 Class A; Immunity: EN50082-1

Warranty

Five-year limited warranty



For more information, visit our World Wide Web site at <http://www.mcg.mot.com>
For fax-back service dial 1-800-682-6128 in the U.S. and 602-438-4636 outside of the U.S.
To call us dial 1-800-759-1107 in the U.S. and 512-434-1526 outside of the U.S.
Corporate headquarters address: Motorola Computer Group, 2900 S. Diablo Way, Tempe, AZ 85282

Copyright 1998 Motorola, Inc.
Data Sheet: PV100-D1

Motorola and the Motorola logo are registered trademarks of Motorola, Inc. Intel and Pentium are registered trademarks; and MMX is a trademark of Intel Corporation. PICMG is a registered trademark of PCI Industrial Computer Manufacturers Group. All other names, products, and/or services mentioned may be trademarks or registered trademarks of their respective holders.

This data sheet identifies products, their specifications, and their characteristics, which may be suitable for certain applications. It does not constitute an offer to sell or a commitment of present or future availability, and should not be relied upon to state the terms and conditions, including warranties and disclaimers thereof, on which Motorola may sell products. A prospective buyer should exercise its own independent judgement to confirm the suitability of the products for particular applications. Motorola reserves the right to make changes, without notice, to any products or information herein which will, in its sole discretion, improve reliability, function, or design. Motorola does not assume any liability arising out of the application or use of any product or circuit described herein; neither does it convey any license under its patent or other intellectual property rights or under others. This disclaimer extends to any prospective buyer, and it includes Motorola's licensee, licensee's transferees, and licensee's customers and users. Availability of some of the products and services described herein may be restricted in some locations.



MOTOROLA
Computer Group