

Advance Information
Dual PLLs for 46/49 MHz
Cordless Telephones
CMOS

These devices are dual phase-locked loop frequency synthesizers intended for use primarily in 46/49 MHz cordless phones with up to 10 channels. These parts contain two mask-programmable counter ROMs for receive and transmit loops with two independent phase detect circuits. A common reference oscillator and reference divider are shared by the receive and transmit circuits.

Frequency selection is accomplished via a 4-bit parallel input for the MC145160 and MC145166. The MC145167 utilizes a serial interface.

Other features include a lock detect circuit for the transmit loop, illegal code default, and a 5.0 kHz tone output.

- Synthesizes Up to Ten Channel Pairs
- Maximum Operating Frequency: 60 MHz @ $V_{in}=200$ mV p-p
- Operating Temperature Range: -40°C to 75°C
- Operating Voltage Range: 2.5 to 5.5 V
- On-Chip Oscillator Circuit Supports External Crystal
- Lock Detect Signal
- Operating Power Consumption: 3.0 mA @ 3.0 V
- Standby Mode for Power Savings: 1.5 mA @ 3.0 V

Part Number	4.0 kHz Output	Transmit Frequency	Channel Programming
MC145160	Yes	Half of Fundamental	BCD
MC145166	No	Fundamental	BCD
MC145167	No	Fundamental	Serial

MC145160
MC145166
MC145167

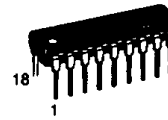

P SUFFIX
 PLASTIC DIP
 CASE 707



P SUFFIX
 PLASTIC DIP
 CASE 648

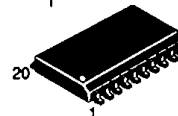

DW SUFFIX
 SOG
 CASE 751D

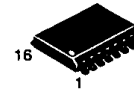

DW SUFFIX
 SOG
 CASE 751G

ORDERING INFORMATION

MC145160P Plastic DIP
 MC145160DW SOG Package

MC145166P Plastic DIP
 MC145166DW SOG Package

MC145167P Plastic DIP
 MC145167DW SOG Package

PIN ASSIGNMENTS

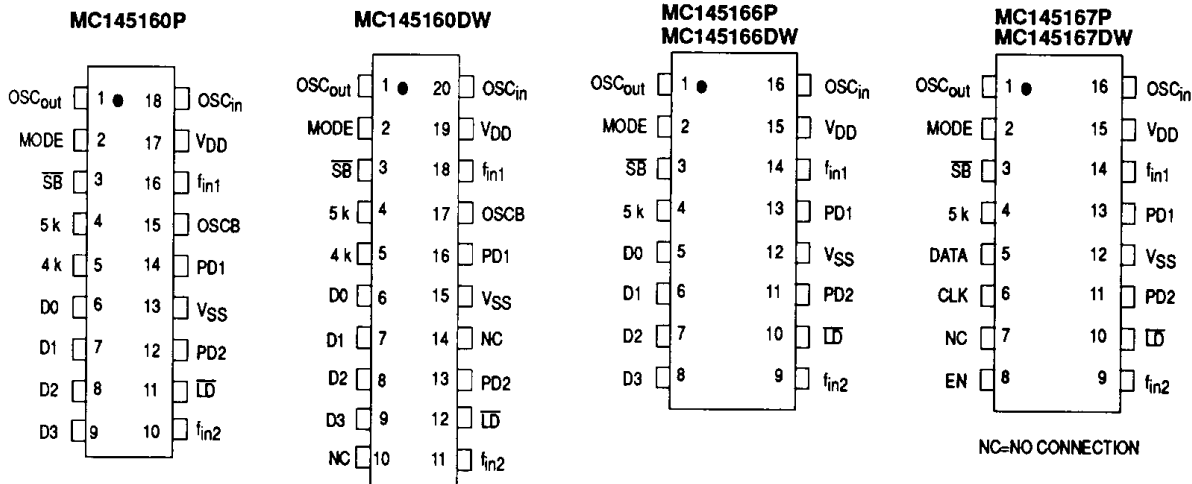

This document contains information on a new product. Specifications and information herein are subject to change without notice.

MC145160•MC145166•MC145167

BLOCK DIAGRAM OF THE MC145160, MC145166, AND MC145167

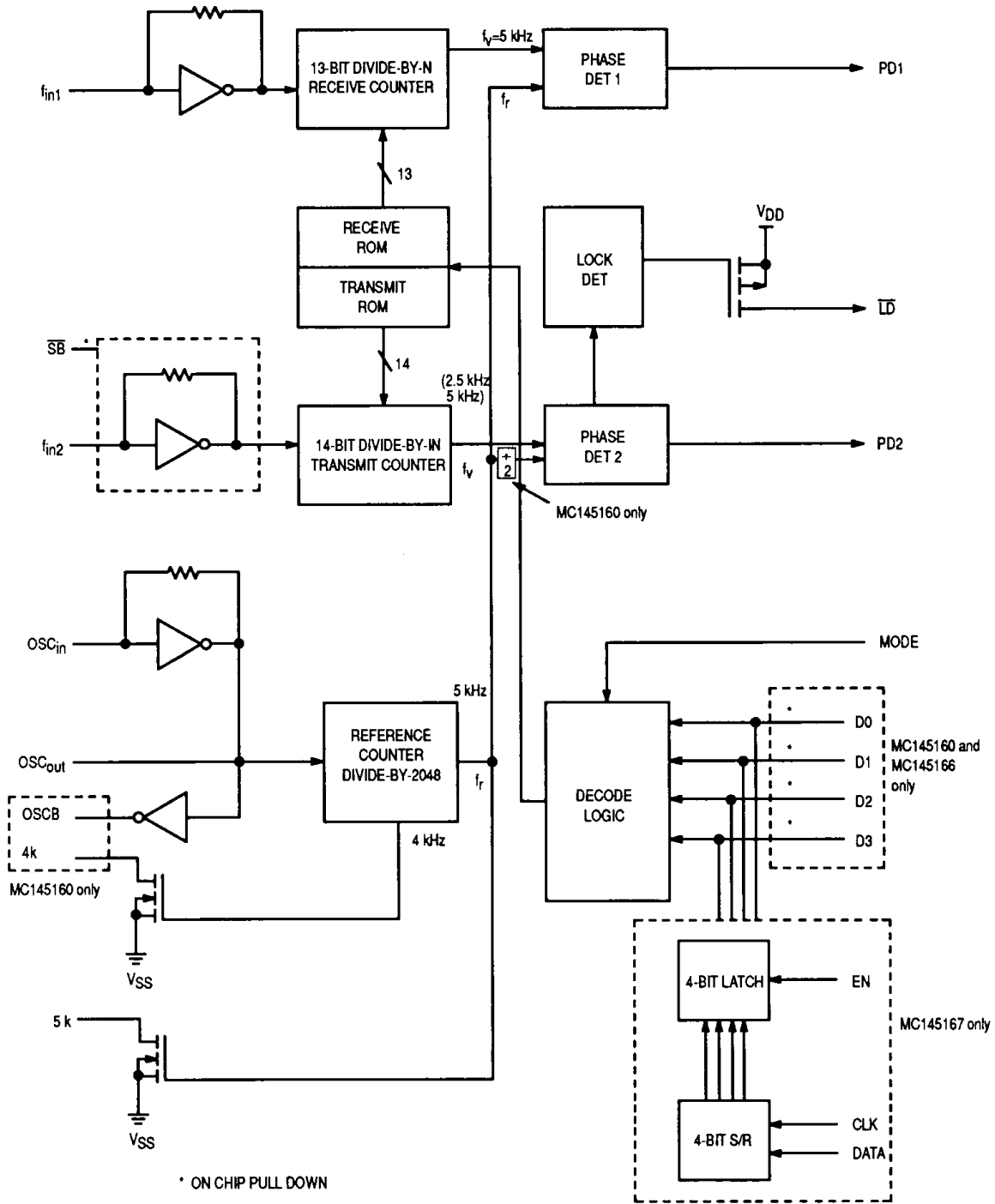

MAXIMUM RATINGS* (Voltages Referenced to V_{SS})

Symbol	Rating	Value	Unit
V _{DD}	DC Supply Voltage	-0.5 to +6.0	V
V _{in}	Input Voltage, All Inputs	-0.5 to V _{DD} +0.5	V
I _{in} , I _{out}	DC Current Drain Per Pin	10	mA
I _{DD} , I _{SS}	DC Current Drain V _{DD} or V _{SS} Pins	30	mA
T _{stg}	Storage Temperature Range	-65 to +150	°C

* Maximum Ratings are those values beyond which damage to the device may occur. Functional operation should be restricted to the limits in the Electrical Characteristics tables or Pin Descriptions section.

This device contains protection circuitry to guard against damage due to high static voltages or electric fields. However, precautions must be taken to avoid applications of any voltage higher than maximum rated voltages to this high-impedance circuit. For proper operation, V_{in} and V_{out} should be constrained to the range V_{SS} ≤ (V_{in} or V_{out}) ≤ V_{DD}. Unused inputs must always be tied to an appropriate logic voltage level (e.g., either V_{SS} or V_{DD}). Unused outputs must be left open.

ELECTRICAL CHARACTERISTICS (Voltages Referenced to V_{SS}, T_A=25°C)

Symbol	Characteristic	V _{DD}	Guaranteed Limit		Unit
			Min	Max	
V _{DD}	Power Supply Voltage Range	—	2.5	5.5	V
V _{OL}	Output Voltage (I _{out} =0)	0 Level	2.5	—	0.05
			5.5	—	0.05
V _{OH}	(V _{in} =V _{DD} or 0)	1 Level	2.5	2.45	—
			5.5	5.45	—
V _{IL}	Input Voltage (V _{out} =0.5 V or V _{DD} -0.5 V)	0 Level	2.5	—	0.75
			5.5	—	1.65
V _{IH}		1 Level	2.5	1.75	—
			5.5	3.85	—
I _{OH}	Output Current (V _{out} =2.2 V) (V _{out} =5.0 V)	Source	2.5	-0.18	—
			5.5	-0.55	—
I _{OL}	(V _{out} =0.3 V) (V _{out} =0.5 V)	Sink	2.5	0.18	—
			5.5	0.55	—
I _{IL}	Input Current (V _{in} =0)	OSC _{in} , f _{in1} , f _{in2}	2.5	—	-30
			5.5	—	-66
		Data, \overline{SB} , Mode	2.5	—	-0.05
			5.5	—	-0.11
I _{IH}	(V _{in} =V _{DD} -0.5)	OSC _{in} , f _{in1} , f _{in2}	2.5	—	30
			5.5	—	66
		Data, \overline{SB} , Mode	2.5	—	50
			5.5	—	121
C _{in}	Input Capacitance	—	—	8.0	pF
C _{out}	Output Capacitance	—	—	8.0	pF
I _{DD}	Standby Current, \overline{SB} =V _{SS} or Open	2.5	—	1.4	mA
		5.5	—	3.6	
I _{dd}	Operating Current (200 mV p-p input at f _{in1} , f _{in2} , \overline{SB} =V _{DD})	2.5	—	2.8	mA
		5.5	—	6.2	
I _{OZ}	Three-State Leakage Current (V _{out} =0 V or 5.5 V)	5.5	—	±1.0	μA

SWITCHING CHARACTERISTICS (T_A=25°C, C_L=50 pF)

Symbol	Characteristic	V _{DD}	Guaranteed Limit		Unit	
			Min	Max		
t _{TLH}	Output Rise Time (Figures 1 and 5)	3.0 5.0	— —	200 100	ns	
t _{THL}	Output Fall Time (Figures 1 and 5)	3.0 5.0	— —	200 100	ns	
t _r , t _f	Input Rise and Fall Time, OSC _{in} (Figure 2)	3.0 5.0	— —	5.0 4.0	μs	
f _{max}	Input Frequency Input=Sine Wave 200 mV p-p	OSC _{in} f _{in1} f _{in2}	3.0-5.0 3.0-5.0 3.0-5.0	— 60 60	12 60 60	MHz
t _{su}	Setup Time (MC145167) (Figure 3)	Data to Clock	3.0 5.0	100 50	— —	ns
		Enable to Clock	3.0 5.0	200 100	— —	
t _h	Hold Time (MC145167), Clock to Data (Figure 3)	3.0 5.0	80 40	— —	ns	
t _{rec}	Recovery Time (MC145167), Enable to Clock (Figure 3)	3.0 5.0	80 40	— —	ns	
t _w	Input Pulse Width (MC145167), Clock and Enable (Figure 4)	3.0 5.0	80 60	— —	ns	

SWITCHING WAVEFORMS

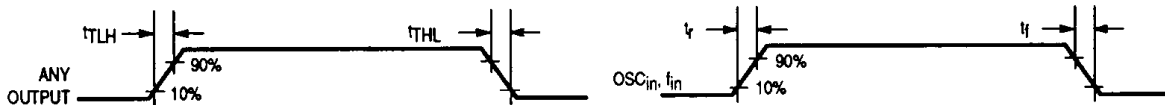

Figure 1.

Figure 2.

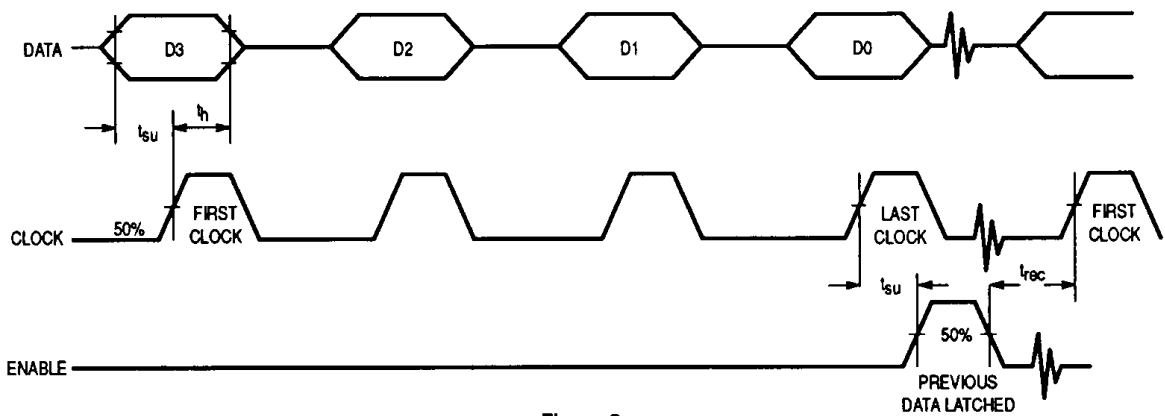

Figure 3.

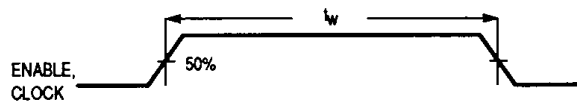

Figure 4.

PIN DESCRIPTIONS

INPUTS

OSC_{in}, OSC_{out}

These pins form a reference oscillator when connected to an external parallel-resonant crystal. For a 46/49 MHz cordless phone application, a 10.24 MHz crystal is needed. OSC_{in} may also serve as input for an externally generated reference signal. This signal is typically ac-coupled to OSC_{in}, but for larger amplitude signals (standard CMOS logic levels) dc coupling may also be used. In the external reference mode, no connection is required for OSC_{out}.

Mode

Mode is for determining whether the part is to be used in the base or handset of a cordless phone. Internally, this pin is used in the decoding logic for selecting the ROM address. When high, the device is set in the base mode, and when low, it is set in the handset mode. This input has an internal pull down device.

SB

The standby pin is used to save power when not transmitting. When high, both the transmit and receive loops are in operation. When low, the transmit loop is disabled, thereby reducing power consumption. This input has an internal pull down device.

D0 through D3

These inputs provide the BCD code for selecting the one of ten channels to be locked in both the transmit and receive loop. When address data other than 1–10 are input, the decoding logic defaults to channel 10. The frequency assignments with reference to Mode and D0–D3 are shown in Table 2. These inputs have internal pull down devices.

f_{in1}, f_{in2}

f_{in1} and f_{in2} are inputs to the divide-by-N receive and transmit counters, respectively. These signals are typically derived from the loop VCO and are ac coupled. For larger amplitude signals (standard CMOS logic levels), dc coupling may be used. The minimum input level is 200 mV p-p.

Clock, Data

These pins provide the BCD input by using serial channel programming instead of parallel. Logical high represents a "1". Each low to high transition of the clock shifts one bit of data into the on-chip shift register.

Enable

The enable pin controls the data transfer from the shift register to the 4-bit latch. A positive pulse latches the data.

OUTPUTS

5 k, 4k

These are 5 kHz and 4 kHz tone signals derived from the reference oscillator, these are N-channel open drain outputs.

LD

Lock detect signal associated with the transmit loop. The lock output goes high to indicate an out-of-lock condition. This is a P-channel open-drain output.

PD1, PD2

These are 3-state outputs of the transmit and receive phase detectors for use as loop error signals.

Frequency f_v>f_r or f_v leading: Output=Negative pulses

Frequency f_v<f_r or f_v lagging: Output=Positive pulses

Frequency f_v=f_r and phase coincidence:

Output=High impedance state

OSCB

Buffered output of the on-chip reference oscillator or externally provided reference. This output is available on the MC145160 only.

POWER

V_{SS}

This pin is the negative supply potential and is usually ground.

V_{DD}

This pin is the positive supply potential and may range from +2.5 to +5.5 volts with respect to V_{SS}.



Table 2. MC145166/7 Divide Ratios and VCO Frequencies

Channels					Handset (Mode=0)				Base (Mode=1)			
D3	D2	D1	D0	CH#	f _{in2} —Transmit		f _{in1} —Receive		f _{in2} —Transmit		f _{in1} —Receive	
					F _{vco} (MHz)	+N	F _{vco} (MHz)	+N	F _{vco} (MHz)	+N	F _{vco} (MHz)	+N
0	0	0	1	1	49.670	9934	35.915	7183	46.610	9322	38.975	7795
0	0	1	0	2	49.845	9969	35.935	7187	46.630	9326	39.150	7830
0	0	1	1	3	49.860	9972	35.975	7195	46.670	9334	39.165	7833
0	1	0	0	4	49.770	9954	36.015	7203	46.710	9342	39.075	7815
0	1	0	1	5	49.875	9975	36.035	7207	46.730	9346	39.180	7836
0	1	1	0	6	49.830	9966	36.075	7215	46.770	9354	39.135	7827
0	1	1	1	7	49.890	9978	36.135	7227	46.830	9366	39.195	7839
1	0	0	0	8	49.930	9986	36.175	7235	46.870	9374	39.235	7847
1	0	0	1	9	49.990	9998	36.235	7247	46.930	9386	39.295	7859
1	0	1	0	10	49.970	9994	36.275	7255	46.970	9394	39.275	7855

NOTES:

1. Other input combinations will be defaulted to channel 10
2. Half the frequency of f_{in2} for MC145160
3. 0=logic low, 1=logic high.

5

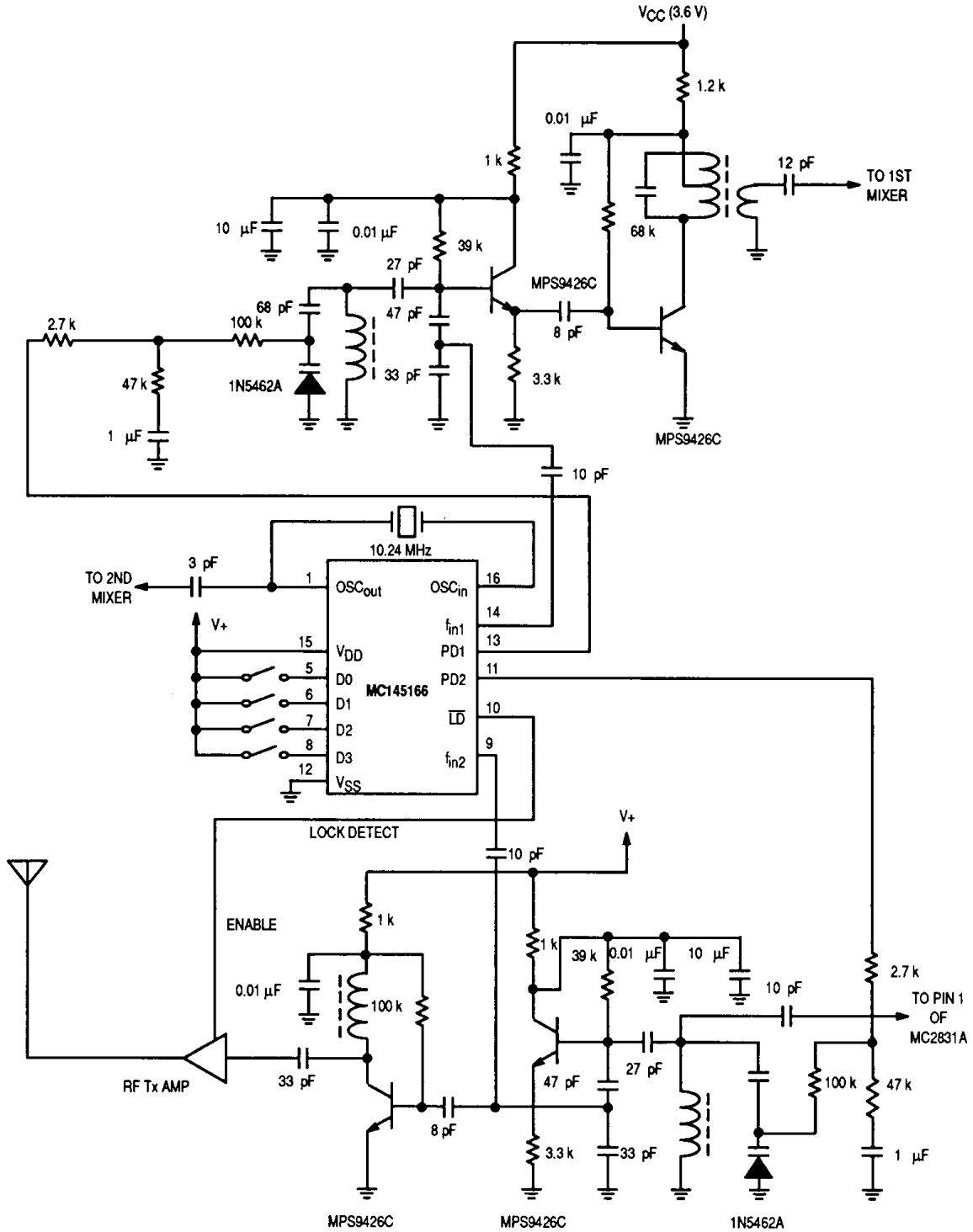

Figure 3. MC145166 Circuit Example

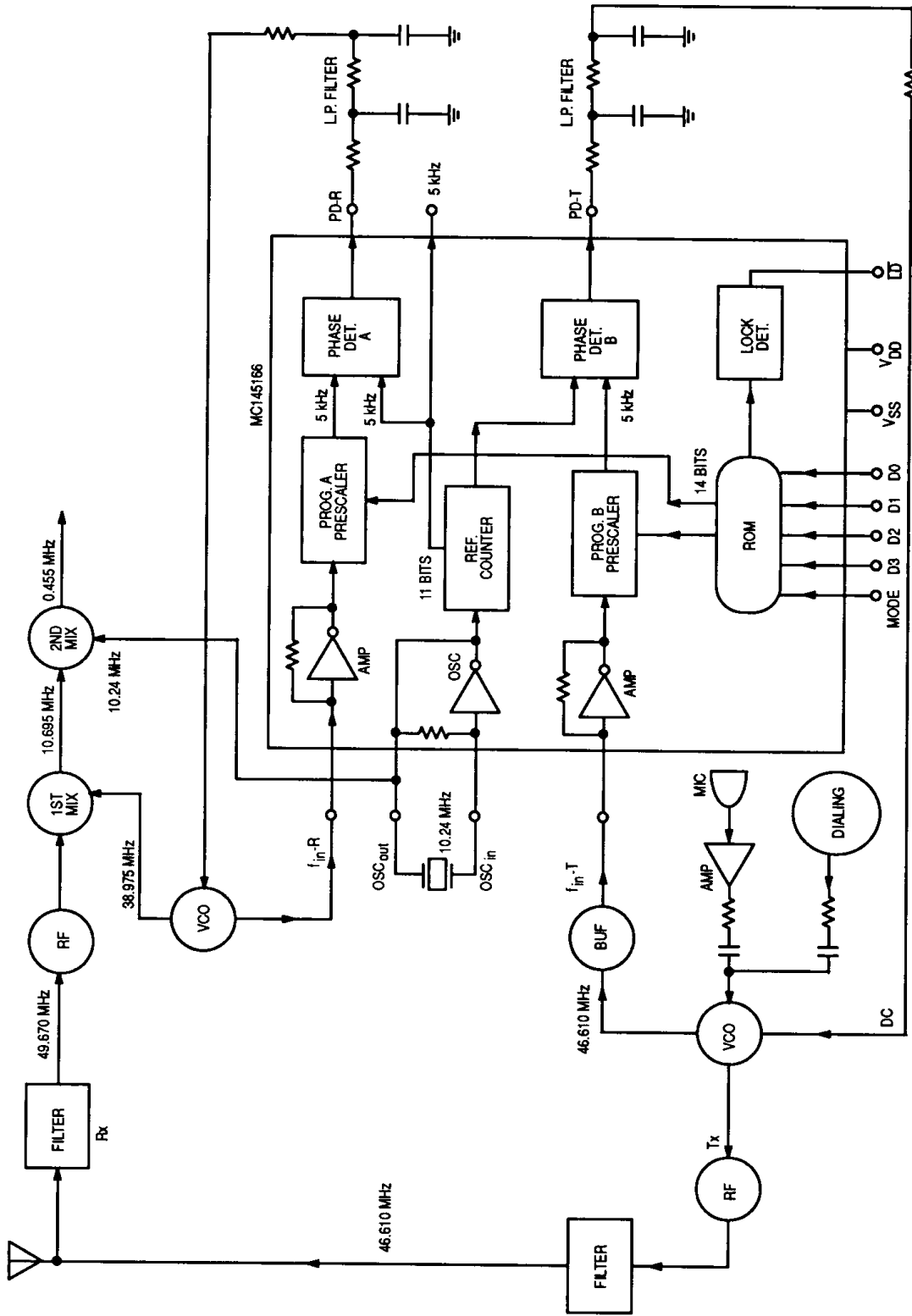

Figure 4. DPLL Application in 46/49 MHz Cordless Phone