



82551ER Fast Ethernet PCI Controller

Networking Silicon - 82551ER

Datasheet

Product Features

- Enhanced IP Protocol Support
 - TCP, UDP, IPv4 Checksum Offload
 - Received Checksum Verification
- Quality of Service (QoS)
 - Multiple Priority Transmit Queues
- Optimum Integration for Lowest Cost Solution
 - Integrated IEEE 802.3 10BASE-T and 100BASE-TX compatible PHY
 - 32-bit PCI master interface
 - Thin BGA 15mm² package
- Integrated power management functions
 - ACPI and PCI Power Management standards compliance
 - Wake on “interesting” packets and link status change support
- High Performance Networking Functions
 - Early release
 - 8255x controller family chained memory structure
 - Improved dynamic transmit chaining with multiple priorities transmit queues
 - Full pin compatibility with the 82559 and 82559ER controllers
 - Backward compatible software to 82559ER controller
 - Full Duplex support at 10 and 100 Mbps
 - IEEE 802.3u Auto-Negotiation support
 - 3 Kbyte transmit and receive FIFOs
 - Fast back-to-back transmission support with minimum interframe spacing
 - IEEE 802.3x 100BASE-TX Flow Control support
 - Adaptive Technology
- Low Power Features
 - Advanced Power Management capabilities
 - Low power 3.3 V device
 - Efficient dynamic standby mode
 - Deep power down support
 - Clockrun protocol support
- 82551ER Enhancements
 - Improved Bit Error Rate performance
 - HWI support
 - Deep Power-down state power reduction



Information in this document is provided in connection with Intel products. No license, express or implied, by estoppel or otherwise, to any intellectual property rights is granted by this document. Except as provided in Intel's Terms and Conditions of Sale for such products, Intel assumes no liability whatsoever, and Intel disclaims any express or implied warranty, relating to sale and/or use of Intel products including liability or warranties relating to fitness for a particular purpose, merchantability, or infringement of any patent, copyright or other intellectual property right. Intel products are not intended for use in medical, life saving, or life sustaining applications.

Intel may make changes to specifications and product descriptions at any time, without notice.

Designers must not rely on the absence or characteristics of any features or instructions marked "reserved" or "undefined." Intel reserves these for future definition and shall have no responsibility whatsoever for conflicts or incompatibilities arising from future changes to them.

The 82551ER may contain design defects or errors known as errata which may cause the product to deviate from published specifications. Current characterized errata are available on request.

Contact your local Intel sales office or your distributor to obtain the latest specifications and before placing your product order.

Copies of documents which have an ordering number and are referenced in this document, or other Intel literature may be obtained by calling 1-800-548-4725 or by visiting Intel's Web site at <http://www.intel.com>.

Copyright © 2003, Intel Corporation.

* Other product and corporate names may be trademarks of other companies and are used only for explanation and to the owners' benefit, without intent to infringe.

Revision History

Revision Date	Revision	Description
Nov 2001	0.7	Initial draft for release (Intel Secret).
Jan 2002	1.0	<ul style="list-style-type: none"> • Added description for No Connect pins. • Clarified EEPROM address map and word definitions for the 82551ER. • Added more detailed information for I_{CC} in the DC specifications table. • Corrected typographical errors.
Apr 2002	2.0	Changed document status to Intel Confidential.
Mar 2003	2.1	<ul style="list-style-type: none"> • Removed document status. • Removed references to MDI/MDI-X feature, which is not supported by the 82551ER.



Contents

1.0	Introduction.....	1
1.1	Overview	1
1.2	Byte Ordering	1
1.3	References	1
1.4	Product Codes.....	1
2.0	Architectural Overview	3
2.1	Parallel Subsystem Overview.....	3
2.2	FIFO Subsystem Overview	3
2.3	10/100 Mbps Serial CSMA/CD Unit Overview	4
2.4	10/100 Mbps Physical Layer Unit.....	4
3.0	Performance Enhancements.....	5
3.1	Multiple Priority Transmit Queues	5
3.2	Early Release	5
3.3	Hardware Integrity Support	6
4.0	Signal Descriptions.....	7
4.1	Signal Type Definitions	7
4.2	PCI Bus Interface Signals	8
4.2.1	Address and Data Signals	8
4.2.2	Interface Control Signals	8
4.2.3	System and Power Management Signals	9
4.3	Local Memory Interface Signals	10
4.4	Test Port Signals	11
4.5	PHY Signals	12
4.6	Power and Ground Signals	13
5.0	Media Access Control Functional Description.....	15
5.1	Device Initialization.....	15
5.1.1	Initialization Effects.....	15
5.2	PCI Interface	16
5.2.1	Bus Operations.....	16
5.2.2	Clockrun Signal	24
5.2.3	Power Management Event	25
5.3	PCI Power Management	25
5.3.1	Power States	25
5.3.2	Wake-up Events	29
5.4	Parallel Flash.....	30
5.5	Serial EEPROM Interface.....	30
5.6	10/100 Mbps CSMA/CD Unit.....	33
5.6.1	Full Duplex	33
5.6.2	Flow Control	33
5.6.3	Address Filtering Modifications	33
5.6.4	Long Frame Reception	34
5.7	Media Independent Interface (MII) Management Interface	34

6.0	Physical Layer Functional Description	35
6.1	100BASE-TX PHY Unit	35
6.1.1	100BASE-TX Transmit Clock Generation	35
6.1.2	100BASE-TX Transmit Blocks	35
6.1.3	100BASE-TX Receive Blocks	35
6.1.4	100BASE-TX Link Integrity Auto-Negotiation.....	36
6.2	10BASE-T PHY Functions	36
6.2.1	10BASE-T Transmit Clock Generation.....	36
6.2.2	10BASE-T Transmit Blocks.....	36
6.2.3	10BASE-T Receive Blocks.....	36
6.2.4	10BASE-T Link Integrity and Full Duplex	37
6.3	Auto-Negotiation	37
6.3.1	Description	37
6.3.2	Parallel Detect and Auto-Negotiation	37
6.4	LED Description	38
7.0	Configuration Registers.....	41
7.1	LAN (Ethernet) PCI Configuration Space.....	41
7.1.1	PCI Vendor ID and Device ID Registers	41
7.1.2	PCI Command Register	42
7.1.3	PCI Status Register.....	43
7.1.4	PCI Revision ID Register.....	44
7.1.5	PCI Class Code Register	44
7.1.6	PCI Cache Line Size Register.....	44
7.1.7	PCI Latency Timer	45
7.1.8	PCI Header Type	45
7.1.9	PCI Base Address Registers.....	45
7.1.10	Base Address Registry Summary	47
7.1.11	PCI Subsystem Vendor ID and Subsystem ID Registers.....	47
7.1.12	Capability Pointer	48
7.1.13	Interrupt Line Register.....	48
7.1.14	Interrupt Pin Register	48
7.1.15	Minimum Grant Register	48
7.1.16	Maximum Latency Register.....	48
7.1.17	Capability ID Register	48
7.1.18	Next Item Pointer	48
7.1.19	Power Management Capabilities Register	49
7.1.20	Power Management Control/Status Register (PMCSR).....	49
7.1.21	Data Register	50
8.0	Control/Status Registers	51
8.1	LAN (Ethernet) Control/Status Registers	51
8.1.1	System Control Block Status Word	52
8.1.2	System Control Block Command Word.....	53
8.1.3	System Control Block General Pointer.....	53
8.1.4	PORT	53
8.1.5	Flash Control Register	53
8.1.6	EEPROM Control Register.....	54
8.1.7	Management Data Interface Control Register.....	54
8.1.8	Receive Direct Memory Access Byte Count.....	54

8.1.9	Flow Control Register	54
8.1.10	General Control Register.....	55
8.1.11	General Status Register	55
8.2	Statistical Counters	55
9.0	PHY Unit Registers	59
9.1	MDI Registers 0 - 7	59
9.1.1	Register 0: Control Register	59
9.1.2	Register 1: Status Register	60
9.1.3	Register 2: PHY Identifier Register	61
9.1.4	Register 3: PHY Identifier Register	61
9.1.5	Register 4: Auto-Negotiation Advertisement Register	61
9.1.6	Register 5: Auto-Negotiation Link Partner Ability Register	62
9.1.7	Register 6: Auto-Negotiation Expansion Register	62
9.2	MDI Registers 8 - 15	62
9.3	MDI Register 16 - 31	63
9.3.1	Register 16: PHY Unit Status and Control Register	63
9.3.2	Register 17: PHY Unit Special Control Register	63
9.3.3	Register 18: PHY Address Register.....	64
9.3.4	Register 19: 100BASE-TX Receive False Carrier Counter	64
9.3.5	Register 20: 100BASE-TX Receive Disconnect Counter	65
9.3.6	Register 21: 100BASE-TX Receive Error Frame Counter	65
9.3.7	Register 22: Receive Symbol Error Counter	65
9.3.8	Register 23: 100BASE-TX Receive Premature End of Frame Error Counter 65	
9.3.9	Register 24: 10BASE-T Receive End of Frame Error Counter	65
9.3.10	Register 25: 10BASE-T Transmit Jabber Detect Counter	66
9.3.11	Register 26: Equalizer Control and Status Register	66
9.3.12	Register 27: PHY Unit Special Control Register	66
9.3.13	Register 28: Reserved.....	66
9.3.14	Register 29: Hardware Integrity Control Register	67
10.0	Electrical and Timing Specifications.....	69
10.1	Absolute Maximum Ratings.....	69
10.2	DC Specifications	69
10.3	AC Specifications	73
10.4	Timing Specifications	74
10.4.1	Clocks Specifications	74
10.4.2	Timing Parameters	75
11.0	Package and Pinout Information	83
11.1	Package Information	83
11.2	Pinout Information	84
11.2.1	Pin Assignments	84
11.2.2	Ball Grid Array Diagram	86



1.0 Introduction

This datasheet is applicable to the Intel® 82551ER Fast Ethernet PCI Controller, a member of the 8255x Fast Ethernet Controller family.

1.1 Overview

The 82551ER is an evolutionary addition to Intel's family of 8255x controllers. It provides excellent performance by offloading TCP, UDP and IP checksums and supports TCP segmentation off-load.

Its optimized 32-bit interface and efficient scatter-gather bus mastering capabilities enable the 82551ER to perform high speed data transfers over the PCI bus. This capability accelerates the processing of high level commands and operations, which lowers CPU utilization. Its architecture enables data to flow efficiently from the bus interface unit to the 3 Kbyte Transmit and Receive FIFOs, providing the perfect balance between the wire and system bus. In addition, multiple priority queues are provided to prevent data underruns and overruns.

The 82551ER includes both a MAC and PHY. It also has a simple interface to the analog front end, which allows cost effective designs requiring minimal board real estate. The 82551ER is pin compatible with the 82550 and 82559 family of controllers and is offered with software that provides backwards compatibility with previous 8255x controllers.

1.2 Byte Ordering

TCP and IP Internet Engineering Task Force (IETF) Request for Comments (RFCs) and literature use big endian (BE) byte ordering. This document uses big endian ordering for all IP and TCP frame formats. However, little endian byte ordering is used for referencing 82551ER memory resident structures and internal structures.

1.3 References

The following documents may provide further information on topics discussed in this document.

- 10/100 Mbit Ethernet Controller Family Software Developer's Manual. Intel Corporation.
- Advanced Configuration and Power Interface Specification, Revision 1.0. Intel Corporation, Microsoft Corporation, and Toshiba.
- IEEE 802.3x and 802.1y Standards.
- Network Device Class Power Management Reference Specification, Revision 1.0a. AMD, Inc. and Microsoft Corporation.

1.4 Product Codes

The product ordering code for the 82551ER is: GD82551ER.



2.0 Architectural Overview

The Intel® 82551ER is divided into four main subsystems: a parallel subsystem, a FIFO subsystem, a 10/100 Mbps Carrier Sense Multiple Access with Collision Detect (CSMA/CD) unit, and a 10/100 Mbps physical layer (PHY) unit.

2.1 Parallel Subsystem Overview

The parallel subsystem is comprised of several functional blocks: a PCI bus master interface, a micromachine processing unit and its corresponding microcode ROM, and a PCI Target Control/Flash/EEPROM interface. The parallel subsystem also interfaces to the FIFO subsystem, passing data (such as transmit, receive, and configuration data) and command and status parameters between these two blocks.

The PCI bus master interface provides a complete glueless interface to a PCI bus and is compliant with the PCI Bus Specification, Revision 2.2. The 82551ER provides 32 bits of addressing and data, as well as the PCI control interface. As a PCI target, it conforms to the PCI configuration scheme, which allows all accesses to the 82551ER to be automatically mapped into free memory and I/O space upon initialization of a PCI system. When transmit and receive data is processed, the 82551ER operates as a master on the PCI bus, initiating zero wait state transfers.

The 82551ER Control/Status Register Block is part of the PCI target element. The Control/Status Register block consists of the following 82551ER internal control registers: System Control Block (SCB), PORT, Flash Control, EEPROM Control, and Management Data Interface (MDI) Control.

An embedded micromachine consisting of independent transmit and receive processing units allow the 82551ER to execute commands and receive incoming frames with no real time CPU intervention.

The 82551ER contains a multiplexed interface to connect an external serial EEPROM and Flash memory. The Flash interface, which can also be used to connect to any standard 8-bit device, provides up to 128 Kbyte of addressing to the Flash. Both read and write accesses are supported. The Flash can be used for remote boot functions, network statistical and diagnostics functions, and management functions. The Flash is mapped into host system memory (anywhere within the 32-bit memory address space) for software accesses. It is also mapped into an available boot expansion ROM location during boot time of the system. More information on the Flash interface is detailed in Section 5.4, “Parallel Flash”. The serial EEPROM is used to store relevant information for a LAN connection such as node address, as well as board manufacturing and configuration information. Both read and write accesses to the EEPROM are supported by the 82551ER. Information on the EEPROM interface is detailed in Section 5.5, “Serial EEPROM Interface”.

2.2 FIFO Subsystem Overview

The 82551ER FIFO subsystem consists of independent 3 Kbyte transmit and receive FIFOs. Each FIFO provides a temporary buffer for frames as they are transmitted or received. Transmit frames queued within the transmit FIFO allow back-to-back transmission within the minimum Interframe Spacing (IFS). The FIFOs allow the 82551ER to withstand long PCI bus latencies without losing incoming data. Additional attributes of the FIFOs that enhance performance and functionality are:

- Tunable transmit FIFO threshold allows elimination of underruns while concurrent transmits are being performed.
- Extended PCI zero wait state burst accesses to and from the 82551ER for both transmit and receive FIFOs
- Efficient re-transmission of data directly from the transmit FIFO when physical or data link errors (collision detection or data underrun) are encountered, increasing performance by eliminating the need to re-access the data from host memory
- Automatic discard of incoming runt receive frames

The 82551ER FIFO Subsystem consists of independent 3 Kbyte transmit and receive FIFOs. Each FIFO provides a temporary buffer for frames as they are received or transmitted. Transmit frames queued within the transmit FIFO allow back-to-back transmission within the minimum Interframe Spacing (IFS). The FIFOs allow the 82551ER to withstand long PCI bus latencies without losing incoming data. Additional attributes of the FIFOs that enhance performance and functionality are:

2.3 10/100 Mbps Serial CSMA/CD Unit Overview

The 82551ER's CSMA/CD unit allows it to be connected to a 10 or 100 Mbps Ethernet network at half or full duplex. The CSMA/CD unit performs all of the functions of the 802.3 protocol such as frame formatting, frame stripping, collision handling, deferral to link traffic, etc.

2.4 10/100 Mbps Physical Layer Unit

The integrated Physical Layer (PHY) unit of the 82551ER allows connection to either a 10 or 100 Mbps Ethernet network. The PHY supports Auto-Negotiation for 100BASE-TX Full Duplex, 100BASE-TX Half Duplex, 10BASE-T Full Duplex, and 10BASE-T Half Duplex. Three LED pins indicate link status, network activity, and speed.

3.0 Performance Enhancements

All of Intel's Fast Ethernet controllers have the ability to support full wire speeds. The 82551ER has been designed to provide improved networking throughput. Performance is limited to the system's ability to feed data to the network controller.

As networks grow, the task of servicing the network becomes a large burden on the platform. System bottlenecks prevent optimal performance in typical operating conditions. Thus, to help alleviate these issues, Network Operating System (NOS) vendors are establishing normalized off-load specifications. These specifications define the types of off-load support required by the OS and interface between the network drivers. The 82551ER provides support for these initiatives and enables an improvement in platform network efficiency. With the pervasiveness of Internet Protocols, the off-load capabilities have focused on improving IP efficiency. As part of this effort, the 82551ER includes support for Multiple Priority Transmit Queues.

3.1 Multiple Priority Transmit Queues

The 82551ER supports two queues: High Priority Queue (HPQ) and Low Priority Queue (LPQ). The 82551ER provides a method for the driver to modify the HPQ while processing data. A new read only register is defined in the Control/Status Register (CSR) that enables the driver to change the transmit priority of elements within the HPQ. When software reads this register, the address of the next Command Block to be processed by the 82551ER on the HPQ is returned. After reading this register, software can freely modify the next Command Block (for example, overwrite it with a different Command Block) and any subsequent Command Block, without any conflict with the 82551ER.

Note: The Command Block Pointer register (in the CSR) is only active when the device is in the enhanced 82551ER mode.

3.2 Early Release

Like the 82558, 82559 and 82559ER, the 82551ER supports a 3Kbyte transmit FIFO. The 82551ER provides a transmit FIFO enhancement called "early release" that effectively increases the amount of free capacity in the transmit FIFO. The enabling of early release is controlled through configuration space and occurs when the following conditions are met:

1. The transmitted frame is the oldest one in the queue (in other words, it is located at the head of the queue).
2. The transmitted frame has been completely transferred to the XMT-SRAM and processed (for example, XSUM). Large frames (greater than 3 Kbyte) are never candidates for an early release.
3. When the preemptive queue mechanism is on, a frame which satisfies condition 2 may not satisfy condition 1 and therefore will not benefit from an early release.
4. More than 128 bytes have already been transferred to the XMT-SYNC-FIFO. This condition guarantees that at least one slot time elapsed (collision window).

3.3 Hardware Integrity Support

Cabling problems are a common cause for network downtime situations. Hardware Integrity (HWI) can help reduce this by locating cabling problems. It uses transmission line theory to measure the arrival time and electrical characteristics of the wave reflected from an incident test wave launched on the media. With these measurements, opens, shorts, and degraded cable quality can be located along the wire.

HWI is controlled and activated by software. The Hardware Integrity Control, register 29 of the MDI Registers, is used for activating HWI (Section 11.3.14, “Register 29: Hardware Integrity Control”).

4.0 Signal Descriptions

4.1 Signal Type Definitions

Table 1. Signal Type Descriptions

Type	Name	Description
IN	Input	The input pin is a standard input only signal.
OUT	Output	The output pin is a Totem Pole Output pin and is a standard active driver.
TS	Tri-State	The tri-state pin is a bidirectional, input/output pin.
STS	Sustained Tri-State	The sustained tri-state pin is an active low tri-state signal owned and driven by one agent at a time. The agent asserting the STS pin low must drive it high at least one clock cycle before floating the pin. A new agent can only assert an STS signal low one clock cycle after it has been tri-stated by the previous owner.
OD	Open Drain	The open drain pin allows multiple devices to share this signal as a wired-OR.
AI	Analog Input	The analog input pin is used for analog input signals.
AO	Analog Output	The analog output pin is used for analog output signals.
B	Bias	The bias pin is an input bias.
DPS	Digital Power Supply	Digital power or ground for the device.
APS	Analog Power Supply	Analog power or ground for the device.

4.2 PCI Bus Interface Signals

4.2.1 Address and Data Signals

Table 2. Address and Data Signals

Symbol	Type	Name and Function
AD[31:0]	TS	Address and Data. The address and data lines are multiplexed on the same PCI pins. A bus transaction consists of an address phase followed by one or more data phases. During the address phase, the address and data lines contain the 32-bit physical address. For I/O, this is a byte address; for configuration and memory, it is a Dword address. The 82551ER uses little-endian byte ordering (in other words, AD[31:24] contain the most significant byte and AD[7:0] contain the least significant byte). During the data phases, the address and data lines contain data.
C/BE[3:0]#	TS	Command and Byte Enable. The bus command and byte enable signals are multiplexed on the same PCI pins. During the address phase, the C/BE# lines define the bus command. During the data phase, the C/BE# lines are used as Byte Enables. The Byte Enables are valid for the entire data phase and determine which byte lanes carry meaningful data.
PAR	TS	Parity. Parity is even across AD[31:0] and C/BE[3:0]# lines. It is stable and valid one clock after the address phase. For data phases, PAR is stable and valid one clock after either IRDY# is asserted on a write transaction or TRDY# is asserted on a read transaction. Once PAR is valid, it remains valid until one clock after the completion of the current data phase. The master drives PAR for address and write data phases; and the target, for read data phases.

4.2.2 Interface Control Signals

Table 3. Interface Control Signals

Symbol	Type	Name and Function
FRAME#	STS	Cycle Frame. The cycle frame signal is driven by the current master to indicate the beginning and duration of a transaction. FRAME# is asserted to indicate the start of a transaction and de-asserted during the final data phase.
IRDY#	STS	Initiator Ready. The initiator ready signal indicates the bus master's ability to complete the current data phase and is used in conjunction with the target ready (TRDY#) signal. A data phase is completed on any clock cycle where both IRDY# and TRDY# are sampled asserted (low) simultaneously.
TRDY#	STS	Target Ready. The target ready signal indicates the selected device's ability to complete the current data phase and is used in conjunction with the initiator ready (IRDY#) signal. A data phase is completed on any clock cycle where both IRDY# and TRDY# are sampled asserted (low) simultaneously.
STOP#	STS	Stop. The stop signal is driven by the target to indicate to the initiator that it wishes to stop the current transaction. As a bus slave, STOP# is driven by the 82551ER to inform the bus master to stop the current transaction. As a bus master, STOP# is received by the 82551ER to stop the current transaction.

Table 3. Interface Control Signals

Symbol	Type	Name and Function
IDSEL	IN	Initialization Device Select. The initialization device select signal is used by the 82551ER as a chip select during PCI configuration read and write transactions. This signal is provided by the host in PCI systems.
DEVSEL#	STS	Device Select. The device select signal is asserted by the target once it has detected its address. As a bus master, the DEVSEL# is an input signal to the 82551ER indicating whether any device on the bus has been selected. As a bus slave, the 82551ER asserts DEVSEL# to indicate that it has decoded its address as the target of the current transaction.
REQ#	TS	Request. The request signal indicates to the bus arbiter that the 82551ER desires use of the bus. This is a point-to-point signal and every bus master has its own REQ#.
GNT#	IN	Grant. The grant signal is asserted by the bus arbiter and indicates to the 82551ER that access to the bus has been granted. This is a point-to-point signal and every master has its own GNT#.
INTA#	OD	Interrupt A. The interrupt A signal is used to request an interrupt by the 82551ER. This is an active low, level-triggered interrupt signal.
SERR#	OD	System Error. The system error signal is used to report address parity errors. When an error is detected, SERR# is driven low for a single PCI clock.
PERR#	STS	Parity Error. The parity error signal is used to report data parity errors during all PCI transactions except a Special Cycle. The parity error pin is asserted two clock cycles after the error was detected by the device receiving data. The minimum duration of PERR# is one clock for each data phase where an error is detected. A device cannot report a parity error until it has claimed the access by asserting DEVSEL# and completed a data phase.

4.2.3 System and Power Management Signals

Table 4. System and Power Management Signals

Symbol	Type	Name and Function
CLK	IN	Clock. The Clock signal provides the timing for all PCI transactions and is an input signal to every PCI device. The 82551ER requires a PCI Clock signal (frequency greater than or equal to 16 MHz) for nominal operation. The 82551ER supports Clock signal suspension using the Clockrun protocol.
CLKRUN#	IN/OUT OD	Clockrun. The Clockrun signal is used by the system to pause or slow down the PCI Clock signal. It is used by the 82551ER to enable or disable suspension of the PCI Clock signal or restart of the PCI clock. When the Clockrun signal is not used, this pin should be connected to an external pull-down resistor.
RST#	IN	Reset. The PCI Reset pin is used to place PCI registers, sequencers, and signals into a consistent state. When RST# is asserted, the 82551ER ignores other PCI signals and all PCI output signals will be tristated. The PCI Reset pin should be pulled high to the main digital power supply.
PME#	OD	Power Management Event. The Power Management Event signal indicates that a power management event has occurred in a PCI bus system.

Table 4. System and Power Management Signals

Symbol	Type	Name and Function
ISOLATE#	IN	Isolate. The Isolate pin is used to isolate the 82551ER from the PCI bus. It also provides PCI Reset pin functionality. When Isolate is active (low), the 82551ER does not drive its PCI outputs (except PME# and CSTSCHG) or sample its PCI inputs (including CLK and RST#). The ISOLATE# pin should be driven by the PCI Reset signal.
ALTRST#	IN	Alternate Reset. The Alternate Reset pin is used to reset the 82551ER on power-up. The Alternate Reset signal should be pulled high to the main digital power supply.
VIO	B IN	Voltage Input/Output. The VIO pin is the voltage bias pin and should be connected to a 5 V supply in a 5 V PCI signaling environment and a 3.3 V supply in 3.3 V signaling environment.

4.3 Local Memory Interface Signals

Note: All unused Flash Address and Data pins **MUST** be left floating. Some of these pins have undocumented test functionality and can cause unpredictable behavior if they are unnecessarily connected to a pull-up or pull-down resistor.

Table 5. Local Memory Interface Signals

Symbol	Type	Name and Function
FLD[7:0]	IN/OUT	Flash Data Input/Output. These pins are used for Flash data interface. These pins should be left floating if the Flash is not used.
FLA[16]/ CLK25	IN/OUT	Flash Address[16]/25 MHz Clock. This multiplexed pin is controlled by the status of the Flash Address[7] (FLA[7]) pin. If FLA[7] is left floating, this pin is used as FLA[16]; otherwise, if FLA[7] is connected to a pull-up resistor, this pin is used as a 25 MHz clock output. This pin should be left floating if the Flash and the CLK25 functionality are not used.
FLA[15]/ EESK	IN/OUT	Flash Address[15]/EEPROM Data Output. During Flash accesses, this multiplexed pin acts as the Flash Address [15] output signal. During EEPROM accesses, it acts as the serial shift clock output to the EEPROM.
FLA[14]/ EEDO	IN/OUT	Flash Address[14]/EEPROM Data Output. During Flash accesses, this multiplexed pin acts as the Flash Address [14] output signal. During EEPROM accesses, this pin accepts serial input data from the EEPROM Data Output pin.
FLA[13]/ EEDI	IN/OUT	Flash Address[13]/EEPROM Data Input. During Flash accesses, this multiplexed pin acts as the Flash Address [13] output signal. During EEPROM accesses, this pin provides serial output data to the EEPROM Data Input pin.
FLA[12:8]	OUT	Flash Address[12:8]. These pins act as Flash address outputs. They should be left floating if Flash is not used.
FLA[7]/ CLKEN	IN/OUT	Flash Address[7]/Clock Enable. This multiplexed pin acts as the Flash Address[7] output signal during nominal operation. When the power-on reset of the 82551ER is active, this pin acts as input control over the FLA[16]/CLK25 output signal. If the FLA[7]/CLKEN pin is connected to a pull-up resistor (3.3 K Ω), a 25 MHz clock signal is provided on the FLA[16]/CLK25 output; otherwise, it is used as FLA[16] output. For systems that do not use the 25 MHz clock output or Flash, this pin should be left floating.

Table 5. Local Memory Interface Signals

Symbol	Type	Name and Function
FLA[6:2]	OUT	Flash Address[6:2]. These pins are used as Flash address outputs. These pins should be left floating if the Flash is not used.
FLA[1]/AUXPWR	TS	Flash Address[1]/Auxiliary Power. This multiplexed pin acts as the Flash Address[1] output signal during nominal operation. When the power-on reset of the 82551ER is active (low), it acts as the power supply indicator. If the 82551ER is fed by auxiliary power, it should be connected to VCC through a pull-up resistor (3.3 KΩ). Otherwise, this pin should be left floating.
FLA[0]/PCIMODE#	TS	Flash Address [0]/PCI Mode. This multiplexed pin acts as the Flash Address[0] output signal during nominal operation. When power-on reset of the 82551ER is active (low), it acts as the input system type. For PCI systems that do not use Flash, this pin should be left floating.
EECS	OUT	EEPROM Chip Select. The EEPROM Chip Select signal is used to assert chip select to the serial EEPROM.
FLCS#	OUT	Flash Chip Select. The Flash Chip Select pin provides an active low Flash chip select signal. This pin should be left floating if Flash is not used.
FLOE#	OUT	Flash Output Enable. This pin provides an active low output enable control (read) to the Flash memory. This pin should be left floating if Flash is not used.
FLWE#	OUT	Flash Write Enable. This pin provides an active low write enable control to the Flash memory. This pin should be left floating if Flash is not used.

4.4 Test Port Signals

Table 6. Test Port Signals

Symbol	Type	Name and Function
TEST	IN	Test Port. If this input pin is high, the 82551ER will enable the test port. During nominal operation this pin should be connected to a pull-down resistor.
TCK	IN	Test Port Clock. This pin is used for the Test Port Clock signal.
TI	IN	Test Port Data Input. This pin is used for the Test Port Data Input signal.
TEXEC	IN	Test Port Execute Enable. This pin is used for the Test Port Execute Enable signal.
TO	OUT	Test Port Data Output. This pin is used for the Test Port Data Output signal.

4.5 PHY Signals

Table 7. PHY Signals

Symbol	Type	Name and Function
X1	AI	Crystal Input One. X1 and X2 can be driven by an external 3.3 V 25 MHz crystal. Otherwise, X1 may be driven by an external metal-oxide semiconductor (MOS) level 25 MHz oscillator when X2 is left floating.
X2	AO	Crystal Input Two. X1 and X2 can be driven by an external 3.3 V 25 MHz crystal. Otherwise, X1 may be driven by an external MOS level 25 MHz oscillator when X2 is left floating.
TDP TDN	AO	Analog Twisted Pair Ethernet Transmit Differential Pair. These pins transmit the serial bit stream for transmission on the Unshielded Twisted Pair (UTP) cable. The current-driven differential driver can be two-level (10BASE-T) or three-level (100BASE-TX) signals depending on the mode of operation. These signals interface directly with an isolation transformer.
RDP RDN	AI	Analog Twisted Pair Ethernet Receive Differential Pair. These pins receive the serial bit stream from the isolation transformer. The bit stream can be two-level (10BASE-T) or three-level (100BASE-TX) signals depending on the mode of operation.
ACTLED#	OUT	Activity LED. The Activity LED pin indicates either transmit or receive activity. When activity is present, the activity LED is on (ACTLED# active low); when no activity is present, the activity LED is off.
LILED#	OUT	Link Integrity LED. The Link Integrity LED pin indicates link integrity. If the link is valid in either 10 or 100 Mbps, the LED is on (LILED# active low); if link is invalid, the LED is off.
SPEEDLED#	OUT	Speed LED. The Speed LED pin indicates the speed. The speed LED will be on at 100 Mbps (SPEEDLED# active low) and off at 10 Mbps.
RBIAS100	B	Reference Bias Resistor (100 Mbps). This pin should be connected to a 619 Ω pull-down resistor. ^a
RBIAS10	B	Reference Bias Resistor (10 Mbps). This pin should be connected to a 549 Ω pull-down resistor. ^b
VREF	B	Voltage Reference. This pin is connected to a 1.25 V \pm 1% external voltage reference generator. To use the internal voltage reference source, this pin should be left floating. Under normal circumstances, the internal voltage reference should be used and this pin would be left open.

a. 619 Ω for RBIAS 100 is only a recommended value and should be fine tuned for specific designs.

b. 549 Ω for RBIAS 10 is only a recommended value and should be fine tuned for specific designs.

4.6 Power and Ground Signals

Table 8. Power and Ground Signals

Symbol	Type	Name and Function
VCC	DPS	Digital 3.3 V Power. The VCC pins should be connected to the main digital power supply. This is 3.3 V _{AUX} in systems with an auxiliary power supply and PCI power in systems without an auxiliary power supply. The power source is configured through the FLA[1]/AUXPWR pin.
VCCR	APS	Analog Power. These pins should be isolated from VCC with a resistor-capacitor (RC) filter.
VSSPL, VSSPP, VSSPT, VSS	DPS	Digital Ground. These pins should be connected to the main digital ground plane.
NC	DPS	No Connect. These pins should not be connected to any circuit. Pull-up or pull-down resistors should not be used.



5.0 Media Access Control Functional Description

5.1 Device Initialization

The 82551ER has six sources for initialization. They are listed according to their precedence:

1. Internal Power-on Reset (POR)
2. ALTRST# pin
3. RST# pin
4. ISOLATE# pin
5. Software Reset (Software Command)
6. Selective Reset (Software Command)

5.1.1 Initialization Effects

The following table shows the effect of each of the different initialization sources on major portions of the 82551ER. The initialization sources are listed in order of precedence. For example, any resource that is initialized by the software reset is also initialized by the D3 to D0 transition and ALTRST# and PCI RST# but not necessarily by the selective reset.

Table 9. Initialization Effects

	Internal POR	ALTRST#	RST#	ISOLATE#	D3 to D0 Transition	Software Reset	Selective Reset
EEPROM read and initialization	✓	✓	✓	✓	--	--	--
Loadable microcode decoded/reset	✓	✓	✓	✓	✓	✓	--
MAC configuration reset and multicast hash	✓	✓	✓	✓	✓	✓	--
Memory pointers and micro-machine state reset	✓	✓	✓	✓	✓	✓	✓
PCI Configuration register reset	✓	✓	✓	✓	✓	--	--
PHY configuration reset	✓	✓	✓	--	--	--	--

Table 9. Initialization Effects

	Internal POR	ALTRST#	RST#	ISOLATE#	D3 to D0 Transition	Software Reset	Selective Reset
Power management event reset	✓	✓	Clear only if no auxiliary power present	Clear only if no auxiliary power present	--	--	--
Statistic counters reset	✓	✓	✓	✓	✓	✓	--
Sampling of configuration input pins	✓	✓	✓	--	--	--	--

5.2 PCI Interface

5.2.1 Bus Operations

After configuration, the 82551ER is ready for its normal operation. As a Fast Ethernet Controller, the role of the 82551ER is to access transmitted data or deposit received data. In both cases the 82551ER, as a bus master device, will initiate memory cycles by way of the PCI bus.

To perform these actions, the 82551ER is controlled and examined by the CPU through its control and status structures and registers. Some of these structures reside in the 82551ER and some reside in system memory. For access to the 82551ER's Control/Status Registers (CSR), the 82551ER acts as a slave device. The 82551ER serves as a slave also while the CPU accesses its 128 Kbyte Flash buffer or its EEPROM.

Section 5.2.1.1 describes the 82551ER slave operation. It is followed by a description of the 82551ER operation as a bus master (initiator) in Section 5.2.1.2.

5.2.1.1 Bus Slave Operation

The 82551ER serves as a target device in the following cases:

- CPU accesses to the 82551ER System Control Block (SCB) Control/Status Registers (CSR)
- CPU accesses to the EEPROM through its CSR
- CPU accesses to the 82551ER PORT address through the CSR
- CPU accesses to the MDI control register in the CSR
- CPU accesses to the Flash control register in the CSR
- CPU accesses to the 128 Kbyte Flash

The CSR and the 1 Mbyte Flash buffer are considered by the 82551ER as totally separated memory spaces. The 82551ER provides separate Base Address Registers (BARs) in the configuration space to distinguish between them. The size of the CSR memory space is 4 Kbyte in the memory space and 64 bytes in the I/O space. The 82551ER treats accesses to these memory spaces differently.

5.2.1.1.1 Control/Status Register (CSR) Accesses

The 82551ER supports zero wait state single cycle memory or I/O mapped accesses to its CSR space. Separate BARs request 4 Kbytes of memory space and 64 bytes of I/O space to accomplish these accesses. The 82551ER provides 4 valid Kbytes of CSR space, which include the following elements:

- System Control Block (SCB) registers
- PORT register
- Flash control register
- EEPROM control register
- MDI control register
- Flow control registers

The following figures show CSR zero wait state I/O read and write cycles. In the case of accessing the Control/Status Registers, the CPU is the initiator and the 82551ER is the target of the transaction.

Figure 1. CSR I/O Read Cycle

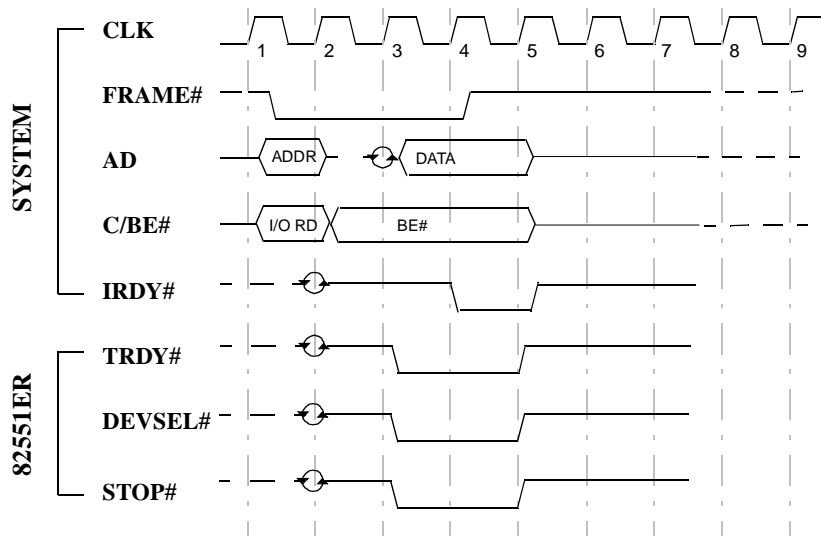

Read Accesses: The CPU, as the initiator, drives address lines AD[31:0], the command and byte enable lines C/BE[3:0]# and the control lines IRDY# and FRAME#. As a slave, the 82551ER controls the TRDY# signal and provides valid data on each data access. The 82551ER allows the CPU to issue only one read cycle when it accesses the Control/Status Registers, generating a disconnect by asserting the STOP# signal. The CPU can insert wait states by de-asserting IRDY# when it is not ready.

Figure 2. CSR I/O Write Cycle

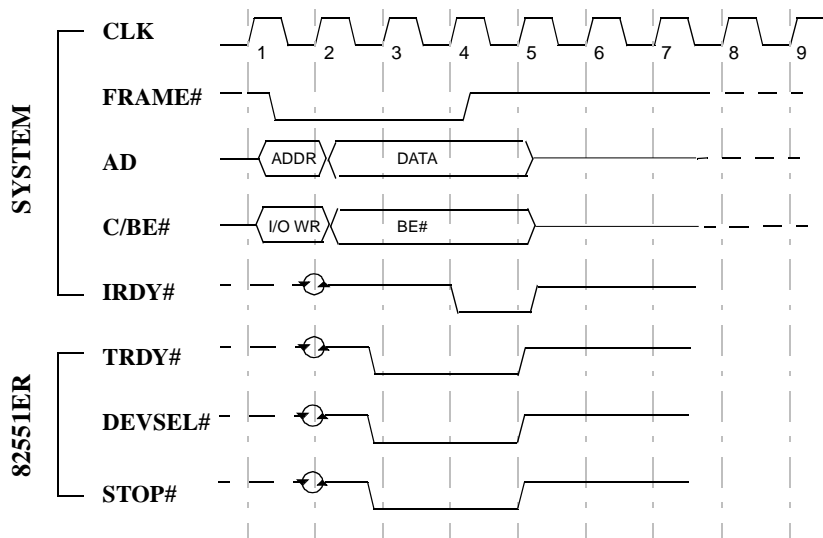

Write Accesses: The CPU, as the initiator, drives the address lines AD[31:0], the command and byte enable lines C/BE#[3:0] and the control lines IRDY# and FRAME#. It also provides the 82551ER with valid data on each data access immediately after asserting IRDY#. The 82551ER controls the TRDY# signal and asserts it from the data access. The 82551ER allows the CPU to issue only one I/O write cycle to the Control/Status Registers, generating a disconnect by asserting the STOP# signal. This is true for both memory mapped and I/O mapped accesses.

5.2.1.1.2 Flash Buffer Accesses

The CPU accesses to the Flash buffer are very slow and the 82551ER issues a target-disconnect at the first data access. The 82551ER asserts the STOP# signal to indicate a target-disconnect. The figures below illustrate memory CPU read and write accesses to the 128 Kbyte Flash buffer. The longest burst cycle to the Flash buffer contains one data access only.

Figure 3. Flash Buffer Read Cycle

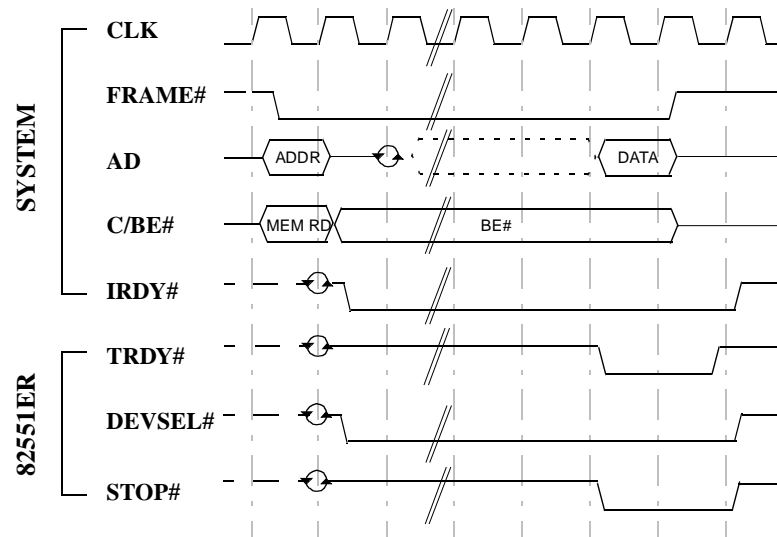

Read Accesses: The CPU, as the initiator, drives the address lines AD[31:0], the command and byte enable lines C/BE[3:0]# and the control lines IRDY# and FRAME#. The 82551ER controls the TRDY# signal and de-asserts it for a certain number of clocks until valid data can be read from the Flash buffer. When TRDY# is asserted, the 82551ER drives valid data on the AD[31:0] lines. The CPU can also insert wait states by de-asserting IRDY# until it is ready. Flash buffer read accesses can be byte or word length.



Figure 4. Flash Buffer Write Cycle

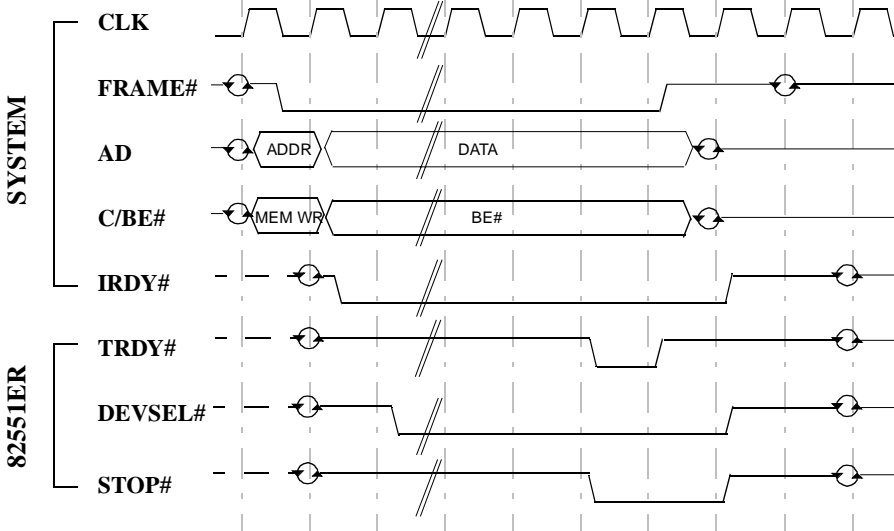

Write Accesses: The CPU, as the initiator, drives the address lines AD[31:0], the command and byte enable lines C/BE[3:0]# and the control lines IRDY# and FRAME#. It also provides the 82551ER with valid data immediately after asserting IRDY#. The 82551ER controls the TRDY# signal and de-asserts it for a certain number of clocks until valid data is written to the Flash buffer. By asserting TRDY#, the 82551ER signals the CPU that the current data access has completed. Flash buffer write accesses can be byte length only.

5.2.1.1.3 Retry Premature Accesses

The 82551ER responds with a Retry to any configuration cycle accessing the 82551ER before the completion of the automatic read of the EEPROM. The 82551ER may continue to Retry any configuration accesses until the EEPROM read is complete. The 82551ER does not enforce the rule that the retry master must attempt to access the same address again to complete any delayed transaction. Any master access to the 82551ER after the completion of the EEPROM read will be honored. Figure 5 below depicts how a Retry looks when it occurs.

Figure 5. PCI Retry Cycle

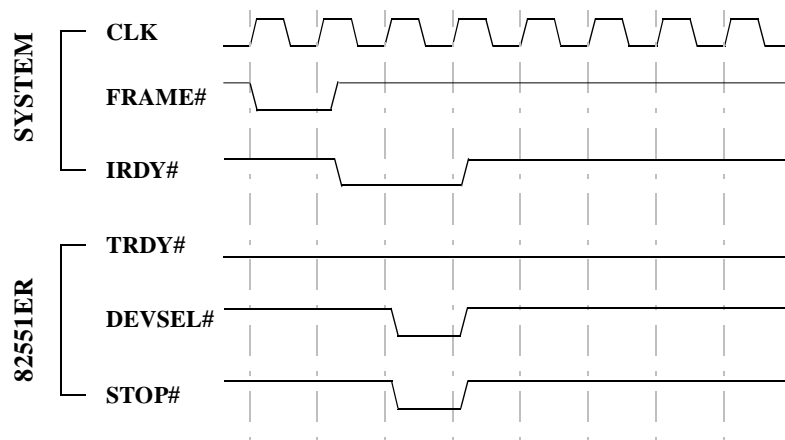

Note: The 82551ER is considered the target in the above diagram; thus, TRDY# is not asserted.

5.2.1.1.4 Error Handling

Data Parity Errors: The 82551ER checks for data parity errors while it is the target of the transaction. If an error was detected, the 82551ER always sets the Detected Parity Error bit in the PCI Configuration Status register, bit 15. The 82551ER also asserts PERR#, if the Parity Error Response bit is set (PCI Configuration Command register, bit 6). The 82551ER does not attempt to terminate a cycle in which a parity error was detected. This gives the initiator the option of recovery.

Target-Disconnect: The 82551ER prematurely terminates a cycle in the following cases:

- After accesses to the Flash buffer
- After accesses to its CSR
- After accesses to the configuration space

System Error: The 82551ER reports parity error during the address phase using the SERR# pin. If the SERR# Enable bit in the PCI Configuration Command register or the Parity Error Response bit is not set, the 82551ER only sets the Detected Parity Error bit (PCI Configuration Status register, bit 15). If SERR# Enable and Parity Error Response bits are both set, the 82551ER sets the Signaled System Error bit (PCI Configuration Status register, bit 14) as well as the Detected Parity Error bit and asserts SERR# for one clock.

Note: The 82551ER detects a system error for any parity error during an address phase, whether or not it is involved in the current transaction.

5.2.1.2 Bus Master Operation

As a PCI Bus Master, the 82551ER initiates memory cycles to fetch data for transmission or deposit received data and to access the memory resident control structures. The 82551ER performs zero wait state burst read and write cycles to the host main memory. Figure 6 and Figure 7 depict memory read and write burst cycles. For bus master cycles, the 82551ER is the initiator and the host main memory (or the PCI host bridge, depending on the configuration of the system) is the target.

Figure 6. Memory Read Burst Cycle

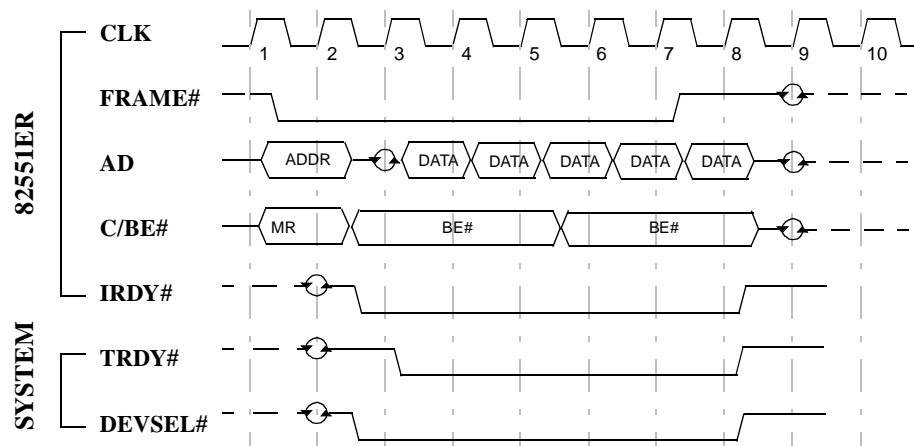
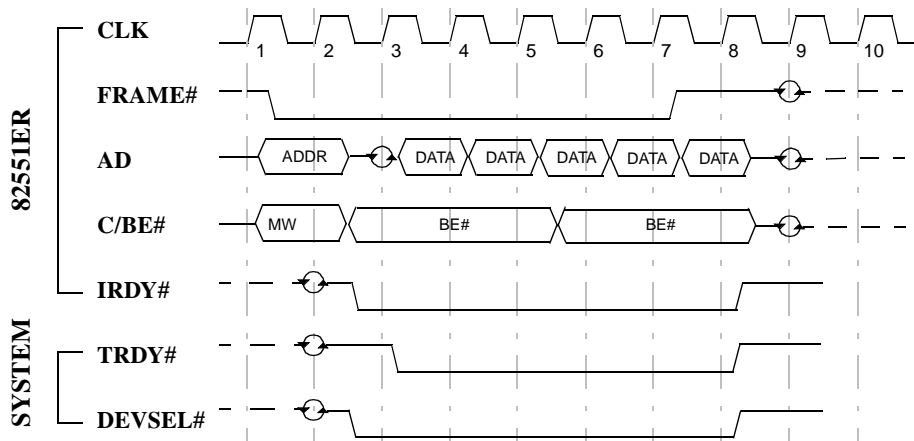

Figure 7. Memory Write Burst Cycle



The CPU provides the 82551ER with action commands and pointers to the data buffers that reside in host main memory. The 82551ER independently manages these structures and initiates burst memory cycles to transfer data to and from them. The 82551ER uses the Memory Read Multiple (MR Multiple) command for burst accesses to data buffers and the Memory Read Line (MR Line)

command for burst accesses to control structures. For all write accesses to the control structure, the 82551ER uses the Memory Write (MW) command. For write accesses to data structure, the 82551ER may use either the Memory Write or Memory Write and Invalidate (MWI) commands.

Read Accesses: The 82551ER performs block transfers from host system memory to perform frame transmission on the serial link. In this case, the 82551ER initiates zero wait state memory read burst cycles for these accesses. The length of a burst is bounded by the system and the 82551ER's internal FIFO. The length of a read burst may also be bounded by the value of the Transmit DMA Maximum Byte Count in the Configure command. The Transmit DMA Maximum Byte Count value indicates the maximum number of transmit DMA PCI cycles that will be completed after an 82551ER internal arbitration.

The 82551ER, as the initiator, drives the address lines AD[31:0], the command and byte enable lines C/BE[3:0]# and the control lines IRDY# and FRAME#. The 82551ER asserts IRDY# to support zero wait state burst cycles. The target signals the 82551ER that valid data is ready to be read by asserting the TRDY# signal.

Write Accesses: The 82551ER performs block transfers to host system memory during frame reception. In this case, the 82551ER initiates memory write burst cycles to deposit the data, usually without wait states. The length of a burst is bounded by the system and the 82551ER's internal FIFO threshold. The length of a write burst may also be bounded by the value of the Receive DMA Maximum Byte Count in the Configure command. The Receive DMA Maximum Byte Count value indicates the maximum number of receive DMA PCI transfers that will be completed before the 82551ER internal arbitration.

The 82551ER, as the initiator, drives the address lines AD[31:0], the command and byte enable lines C/BE[3:0]# and the control lines IRDY# and FRAME#. The 82551ER asserts IRDY# to support zero wait state burst cycles. The 82551ER also drives valid data on AD[31:0] lines during each data phase (from the first clock and on). The target controls the length and signals completion of a data phase by de-assertion and assertion of TRDY#.

5.2.1.2.1 Memory Write and Invalidate

The 82551ER has four Direct Memory Access (DMA) channels. Of these four channels, the Receive DMA is used to deposit the large number of data bytes received from the link into system memory. The Receive DMA uses both the Memory Write (MW) and the Memory Write and Invalidate (MWI) commands. To use MWI, the 82551ER must guarantee the following:

1. Minimum transfer of one cache line
2. Active byte enable bits (or BE[3:0]# are all low) during MWI access
3. The 82551ER may cross the cache line boundary only if it intends to transfer the next cache line too.

To ensure the above conditions, the 82551ER may use the MWI command only if the following conditions are true:

1. The Cache Line Size (CLS) written in the CLS register during PCI configuration is 8 or 16 Dwords.
2. The accessed address is cache line aligned.
3. The 82551ER has at least 8 or 16 Dwords of data in its receive FIFO.
4. There are at least 8 or 16 Dwords of data space left in the system memory buffer.
5. The MWI Enable bit in the PCI Configuration Command register, bit 4, must be set to 1b.

6. The MWI Enable bit in the 82551ER Configure command must be set to 1b.

If any one of the above conditions is not true, the 82551ER uses the MW command. If an MWI cycle has started and one of the conditions is no longer valid (for example, the data space in the memory buffer is now less than CLS), then the 82551ER terminates the MWI cycle at the end of the cache line. The next cycle is either an MW or MWI cycle depending on the conditions listed above.

If the 82551ER started a MW cycle and reached a cache line boundary, it either continues or terminates the cycle depending on the Terminate Write on Cache Line configuration bit of the 82551ER Configure command (byte 3, bit 3). If this bit is set, the 82551ER terminates the MW cycle and attempts to start a new cycle. The new cycle is an MWI cycle if this bit is set and all of the above conditions are met. If the bit is not set, the 82551ER continues the MW cycle across the cache line boundary if required.

5.2.1.2.2 Read Align

The Read Align feature enhances the 82551ER's performance in cache line oriented systems. In these particular systems, starting a PCI transaction on a non-cache line aligned address may cause low performance.

To resolve this performance anomaly, the 82551ER attempts to terminate transmit DMA cycles on a cache line boundary and start the next transaction on a cache line aligned address. This feature is enabled when the Read Align Enable bit is set in the 82551ER Configure command (byte 3, bit 2).

If this bit is set, the 82551ER operates as follows:

- When the 82551ER is almost out of resources on the transmit DMA (that is, the transmit FIFO is almost full), it attempts to terminate the read transaction on the nearest cache line boundary.
- When the arbitration counter's feature is enabled (in other words, the Transmit DMA Maximum Byte Count value is set in the Configure command), the 82551ER switches to other pending DMAs on cache line boundary only.

This feature is not recommended for use in non-cache line oriented systems since it may cause shorter bursts and lower performance. If this feature is used, it is recommended that the CLS register in PCI Configuration space is set to 8 or 16.

5.2.1.2.3 Error Handling

Data Parity Errors: As an initiator, the 82551ER checks and detects data parity errors that occur during a transaction. If the Parity Error Response bit is set (PCI Configuration Command register, bit 6), the 82551ER also asserts PERR# and sets the Data Parity Detected bit (PCI Configuration Status register, bit 8). In addition, if the error was detected by the 82551ER during read cycles, it sets the Detected Parity Error bit (PCI Configuration Status register, bit 15).

5.2.2 Clockrun Signal

This signal is active in PCI bus operating modes. The Clockrun signal is an open drain I/O signal. It is used as a bidirectional channel between the host and the devices.

- The host de-asserts the CLKRUN# signal to indicate that the clock is about to be stopped or slowed down to a non-operational frequency.

- The host asserts the CLKRUN# signal when the clock is either running at a normal operating frequency or about to be started.
- The 82551ER asserts the CLKRUN# signal to indicate that the PCI clock must prevent the host from stopping or to request that the host restore the clock if it was previously stopped.

Proper operation requires that the system latency from the nominal PCI CLK to CLKRUN# assertion should be less than 0.5 μ s. If the system latency is longer than 0.5 μ s, there is an increase in receive overruns. In these types of systems, the Clockrun functionality should be disabled. In this case, the 82551ER will claim the PCI clock even during idle time. If the CLKRUN# signal is not used, it must be connected to a pull-down resistor.

5.2.3 Power Management Event

The 82551ER supports power management indications in the PCI mode. The PME# output pin provides an indication of a power management event in PCI systems.

5.3 PCI Power Management

The 82551ER supports interesting packet wake-up and the capability to wake the system on a link status change from a low power state. The 82551ER enables the host system to be in a sleep state and remain virtually connected to the network. After a power management event or link status change is detected, the 82551ER will wake the host system. The sections below describe these events, the 82551ER power states, and estimated power consumption at each power state.

5.3.1 Power States

The 82551ER has one set of PCI power management registers and implements all four power states as defined in the Power Management Network Device Class Reference Specification, Revision 1.0. The four device power states, D0 through D3, vary from maximum power consumption at D0 to the minimum power consumption at D3.

PCI transactions are only allowed in the D0 state, except for host accesses to the 82551ER's PCI configuration registers. The D1 and D2 power management states enable intermediate power savings while providing the system wake-up capabilities. In the D3 cold state, the 82551ER can provide wake-up capabilities only if auxiliary power is supplied. Wake-up indications from the 82551ER are provided by the Power Management Event (PME#) signal in PCI implementations

5.3.1.1 D0 Power State

As defined in the Network Device Class Reference Specification, the device is fully functional in the D0 power state. In this state, the 82551ER receives full power and should be providing full functionality. In the 82551ER the D0 state is partitioned into two substates, D0 Uninitialized (D0u) and D0 Active (D0a).

D0u is the 82551ER's initial power state following a Power-on Reset (POR) event and before the Base Address Registers (BARs) are accessed. Initialization of the CSR, Memory, or I/O Base Address Registers in the PCI Configuration space switches the 82551ER from the D0u state to the D0a state.

In the D0a state, the 82551ER provides its full functionality and consumes nominal power. In addition, the 82551ER supports wake on link status change (Section 5.3.2, “Wake-up Events”). While it is active, the 82551ER requires a nominal PCI clock signal (in other words, a clock frequency greater than 16 MHz) for proper operation. During idle time, the 82551ER supports a PCI clock signal suspension using the Clockrun signal mechanism. The 82551ER supports a dynamic standby mode. In this mode, the 82551ER is able to save almost as much power as it does in the static power-down states. The transition to or from standby is done dynamically by the 82551ER and is transparent to the software.

5.3.1.2 D1 Power State

For a device to meet the D1 power state requirements, as specified in the Advanced Configuration and Power Interface (ACPI) Specification, Revision 1.0, it must not allow bus transmission or interrupts; however, bus reception is allowed. Therefore, device context may be lost and the 82551ER does not initiate any PCI activity. In this state, the 82551ER responds only to PCI accesses to its configuration space and system wake-up events.

The 82551ER retains link integrity and monitors the link for any wake-up events such as wake-up packets or link status change. Following a wake-up event, the 82551ER asserts the PME# signal to alert the PCI system.

5.3.1.3 D2 Power State

The ACPI D2 power state is similar in functionality to the D1 power state. If the bus is in the B2 bus power state, the 82551ER will consume less current than it does in the D1 state. In addition to D1 functionality, the 82551ER can provide a lower power mode with wake-on-link status change capability. The 82551ER may enter this mode if the link is down while the 82551ER is in the D2 state. In this state, the 82551ER monitors the link for a transition from an invalid link to a valid link. The 82551ER will not attempt to keep the link alive by transmitting idle symbols or link integrity pulses.¹ The sub-10 mA state due to an invalid link can be enabled or disabled by a configuration bit in the Power Management Driver Register (PMDR).

5.3.1.4 D3 Power State

In the D3 power state, the 82551ER has the same capabilities and consumes the same amount of power as it does in the D2 state. However, it enables the PCI system to be in the Bus Power 3 (B3) state. If the PCI system is in the B3 state (in other words, no PCI power is present), the 82551ER provides wake-up capabilities if it is connected to an auxiliary power source in the system. If PME is disabled, the 82551ER does not provide wake-up capability or maintain link integrity. In this mode, the 82551ER consumes minimal power.

The 82551ER enables a system to be in a sub-5 watt state (low power state) and still be virtually connected. More specifically, the 82551ER supports full wake-up capabilities while it is in the D3 cold state. The 82551ER can be connected to an auxiliary power source (V_{AUX}), which enables it to provide wake-up functionality while the PCI power is off. The typical current consumption of the 82551ER is 125 mA at 3.3 V and a dual power plane is not required. If connected to an auxiliary power source, the 82551ER receives all of its power from the auxiliary source in all power states. When connected to an auxiliary power supply, the 82551ER must have a status indicator of whether the power supply is valid (in other words, auxiliary power is stable). The indication is received at the AUXPWR pin, as described next.

1. For a topology of two 82551ER devices connected by a crossed twisted-pair Ethernet cable, the deep power-down mode should be disabled. If it is enabled, the two devices may not detect each other if the operating system places them into a low power state before both nodes become active.

5.3.1.4.1 Auxiliary Power Signal

The 82551ER senses whether it is connected to the PCI power supply or to an auxiliary power supply (V_{AUX}) through the FLA1/AUXPWR pin. The auxiliary power detection pin (multiplexed with FLA1) is sampled when the 82551ER power-on reset is active. An external pull-up resistor should be connected to the 82551ER if it is fed by V_{AUX} ; otherwise, the FLA1/AUXPWR pin should be left floating. The presence of AUXPWR affects the value reported in the Power Management Capability Register (PCI Configuration Space, offset DEh). The Power Management Capability Register is described in more detail in Section 9.1.20, “Power Management Capabilities Register”.

5.3.1.4.2 Alternate Reset Signal

The 82551ER’s ALTRST# input pin functions as a power-on reset input. Following ALTRST# being driven low, the 82551ER is initialized to a known state. While this function is required, this pin is not needed for it. Since this functionality is provided by the 82551ER’s internal power-on reset signal, this pin should be pulled high to the main digital power supply.

Note: A separate internal power-on reset signal is generated when power is applied to the device. This signal is active while it provides the 82551ER power-on reset function and is also used for sampling configuration inputs.

5.3.1.4.3 Isolate Signal

When the 82551ER is connected to V_{AUX} , it can be powered on while the PCI bus is powered off. In this case, the 82551ER isolates itself from the PCI bus. The 82551ER has a dedicated ISOLATE# pin that must be connected to the PCI Reset signal. Whenever the PCI Bus is in the B3 state, the PCI Reset signal becomes active and the 82551ER isolates itself from the PCI bus. During this state, the 82551ER ignores all PCI signals including the RST# and CLK input signals. It also tristates all PCI outputs, except the PME# signal. In the transition to an active PCI power state (in other words, from B3 bus power state to B0 bus power state), the PCI Reset signal shifts high. This generates an internal hardware reset, which initializes the device (described in Section 5.1.1, “Initialization Effects”).

Some designs in existence may implement the previous recommendations for the RST#, ISOLATE# and ALTRST# input pins. In these cases, the PCI Reset signal is connected to the RST# pin, the PCI power source’s stable power (power good) to the ISOLATE# pin, and the auxiliary power source’s stable power (auxiliary power good) to the ALTRST# pin. It is not necessary for existing working designs to make changes for these signals; however, it is recommended that the changes contained in this document should be included when possible. New designs should implement the recommendations contained in this document.

5.3.1.4.4 PCI Reset Signal

The PCI RST# signal can be activated in one of the following cases:

- Power-up
- Warm boot
- Wake-up (B3 to B0 transition)
- Set to power-down (B0 to B3 transition)

If PME is enabled (in the PCI power management registers), the RST# signal does not affect any PME related circuits (in other words, PCI power management registers, and the wake-up packet would not be affected).

Note: The PCI Specification, Revision 2.2, states that the PCI RST# signal should be active low in the B3 state. (In PCI Specification, Revision 2.1, the PCI RST# signal is undefined during the B3 state.)

The transition from the B3 bus power state to the B0 bus power state occurs on the trailing edge of the PCI RST# signal.

The initialization signal is generated internally in the following cases:

- Active RST# signal while the 82551ER is the D0, D1, or D2 power state
- RST# trailing edge while the 82551ER is in the D3 power state
- ISOLATE# trailing edge

The internal initialization signal resets the PCI Configuration Space, MAC configuration, and memory structure.

The behavior of the RST# and ISOLATE# pins and the internal 82551ER initialization signal are shown in the following figure.

Figure 8. Initialization upon RST# and ISOLATE#

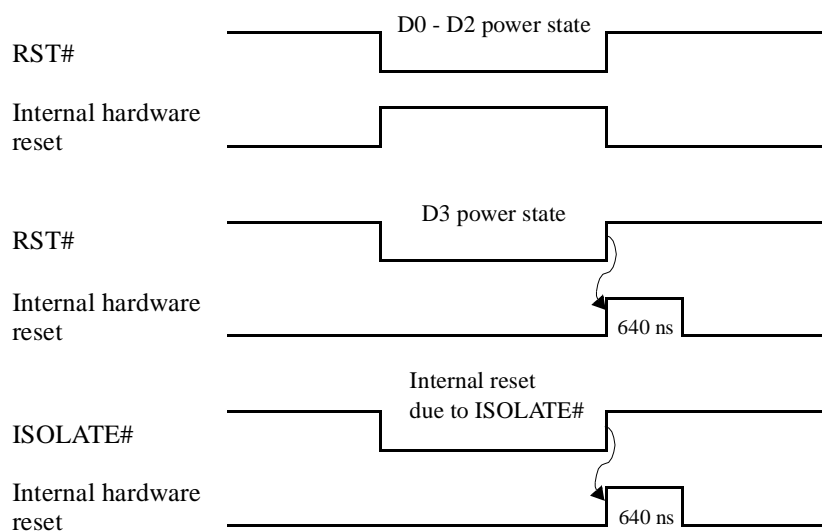

The following tables summarizes the functionality at the different power states for the 82551ER. .

Table 10. Functionality at the Different Power States

Power State	Link	Functionality
D0u	Don't care	<ul style="list-style-type: none"> Power-up state PCI slave access
D0a	Valid	Full functionality at full power and wake on an invalid link
	Invalid	Full functionality at full power and wake on a valid link
D1	Valid	<ul style="list-style-type: none"> Wake-up on "interesting" packets and link invalid PCI configuration access
	Invalid	<ul style="list-style-type: none"> Wake on link valid PCI configuration access
D2	Valid	Same functionality as D1 (link valid)
	Invalid	Detection for valid link and no link integrity
D3 (with power)	Valid	Same functionality as D1 (link valid)
	Invalid	Detection for valid link and no link integrity
Dx (x>0 without PME#)	Don't care	No wake-up functionality

5.3.2 Wake-up Events

There are two types of wake-up events: "Interesting" Packets and Link Status Change. These two events are detailed below.

Note: The wake-up event is supported only if the PME Enable bit in the Power Management Control/Status (PMCSR) register is set. The PMCSR is described in Section 9.1.21, "Power Management Control/Status Register (PMCSR)".

5.3.2.1 "Interesting" Packet Event

In the power-down state, the 82551ER is capable of recognizing "interesting" packets. The 82551ER supports pre-defined and programmable packets that can be defined as any of the following:

- Address Resolution Protocol (ARP) Packets (with Multiple IP addresses)
- Direct Packets (with or without type qualification)
- Neighbor Discovery Multicast Address Packet ("ARP" in IPv6 environment)
- NetBIOS over TCP/IP (NBT) Query Packet (under IPv4)
- Internetwork Package Exchange* (IPX*) Diagnostic Packet

This allows the 82551ER to handle various packet types. In general, the 82551ER supports programmable filtering of any packet in the first 128 bytes.

5.3.2.2 Link Status Change Event

The 82551ER link status indication circuit is capable of issuing a PME on a link status change from a valid link to an invalid link condition or vice versa. The 82551ER reports a PME link status event in all power states. The PME# signal is gated by the PME Enable bit in the PMCSR and the CSMA Configure command.

5.4 Parallel Flash

The 82551ER's parallel interface is used for Flash interface. The 82551ER supports a glueless interface to an 8-bit wide, 128 Kbyte, parallel memory device.

The Flash (or boot PROM) is read from or written to whenever the host CPU performs a read or a write operation to a memory location that is within the Flash mapping window. All accesses to the Flash, except read accesses, require the appropriate command sequence for the device used. (Refer to the specific Flash data sheet for more details on reading from or writing to the Flash device.) The accesses to the Flash are based on a direct decode of CPU accesses to a memory window defined in either the 82551ER Flash Base Address Register (PCI Configuration space at offset 18h) or the Expansion ROM Base Address Register (PCI Configuration space at offset 30h). The 82551ER asserts control to the Flash when it decodes a valid access.

The 82551ER supports an external Flash memory (or boot PROM) of up to 128 Kbyte. The Expansion ROM address can be separately disabled by setting the corresponding bit in the EEPROM, word Ah.

Note: Flash accesses must always be assembled or disassembled by the 82551ER whenever the access is greater than a byte-wide access. Due to slow access times to a typical Flash and to avoid violating PCI bus holding specifications (no more than 16 wait states inserted for any cycles that are not system initiation cycles), the maximum data size is either one word or one byte for a read operation and one byte only for a write operation.

5.5 Serial EEPROM Interface

The serial EEPROM stores configuration data for the 82551ER and is a serial in/serial out device. The 82551ER supports either a 64-register or 256-register size EEPROM and automatically detects the EEPROM's size. A 256-word EEPROM device is required for a TCO enabled system to hold the heartbeat packet. The EEPROM should operate at a frequency of at least 1 MHz.

All accesses, either read or write, are preceded by a command instruction to the device. The address field is six bits for a 64-register EEPROM or eight bits for a 256-register EEPROM. The end of the address field is indicated by a dummy zero bit from the EEPROM, which indicates the entire address field has been transferred to the device. An EEPROM read instruction waveform is shown in the figure below.

Figure 9. 64-Word EEPROM Read Instruction Waveform

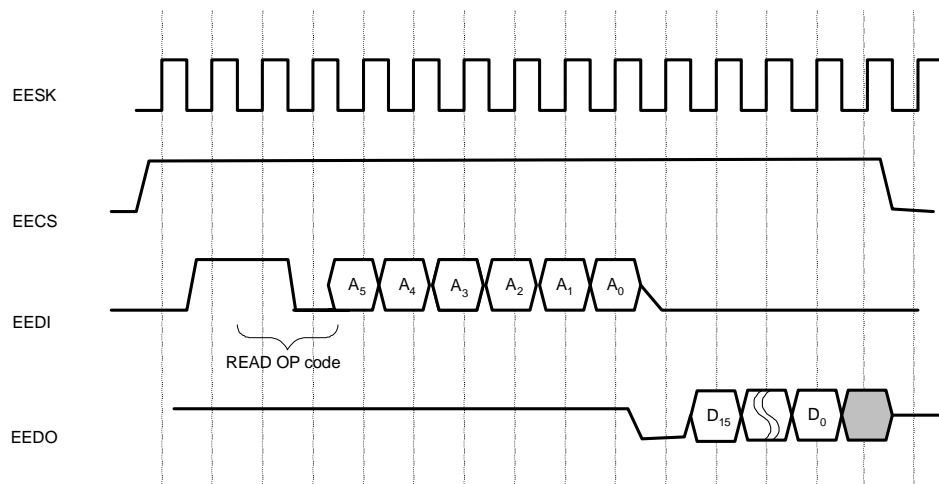

The 82551ER can also use the EEPROM for heartbeat packet transmission (systems without a TCO controller are also supported). In these designs, the EEPROM is accessed through time windows autonomously by the 82551ER hardware. During these time windows, the 82551ER will respond with a PCI Retry to both EEPROM and Flash accesses.

The 82551ER performs an automatic read of five words (0h, 1h, 2h, Ah, and Dh) of the EEPROM after the de-assertion of Reset.

The 82551ER EEPROM format is shown below in Table 11.

Table 11. EEPROM Address Map

Word	High Byte (Bits 15 – 8)	Low Byte (Bits 7 – 0)
00h	Ethernet Individual Address Byte 2	Ethernet Individual Address Byte 1
01h	Ethernet Individual Address Byte 4	Ethernet Individual Address Byte 3
02h	Ethernet Individual Address Byte 6	Ethernet Individual Address Byte 5
0Ah	EEPROM_ID (high byte)	EEPROM_ID (low byte)
0Bh	Subsystem_ID (high byte)	Subsystem_ID (low byte)
0Ch	Subsystem_Vendor (high byte)	Subsystem_Vendor (low byte)
0Dh	Reserved	Reserved
0Eh	Reserved	Reserved
0Fh	Reserved	Reserved
FBh – FEh	Reserved	
FFh	256-word EEPROM Checksum (high byte)	256-word EEPROM Checksum (low byte)

Note: Word Ah contains several configuration bits. Bits from word Ah, FBh through FEh, and certain bits from word Dh are described as follows:

Table 12. EEPROM Words Field Descriptions

Bits	Name	Description
Word Ah, 15:14	Signature	The Signature field is a signature of 01b, indicating to the 82551ER that there is a valid EEPROM present. If the Signature field is not 01b, the other bits are ignored and the default values are used. The default configuration values are: <ul style="list-style-type: none"> • Revision ID (01b) • Standby mode disabled • Deep power-down enabled • Boot ROM enabled and boot expansion ROM base address register disabled • Subsystem ID and System Vendor ID set to 00b
Word Ah, 13	ID	The ID bit indicates how the Subsystem ID and Subsystem Vendor ID fields are used as described in Section 9.1.12, "PCI Subsystem Vendor ID and Subsystem ID Registers". Default value is 0b. If the controller detects the presence of a valid EEPROM (Signature bits equal 01b), the following operations are performed depending on the value of the ID bit: '0' The PCI Device ID is loaded with the contents of word 23h, and the PCI Vendor ID is loaded with the contents of word 0Ch. '1' The PCI Device ID is loaded with the contents of word 23h, and the PCI Vendor ID is loaded with the value 8086h.
Word Ah, 12	Reserved	This bit is reserved and should be set to 0b.
Word Ah, 11	Boot Disable	The Boot Disable bit disables the Expansion ROM Base Address Register (PCI Configuration space, offset 30h) when it is set to 1b. Default value is 0b.
Word Ah, 10:8	Alternate Revision ID	These three bits are used as the three least significant bits of the device revision, if bits 15, 14, and 13 equal 011b and the ID was set as described in Section 9.1.12, "PCI Subsystem Vendor ID and Subsystem ID Registers". The default value depends on the silicon revision. Note: The Alternate Revision ID field in the EEPROM is active only if the ID bit (bit 13) is set to 1b. The default value for this field is 000b.
Word Ah, 7	Reserved	This field is reserved and should be set to 0b.
Word Ah, 6	Deep Power Down	Disable Deep Power Down in the D2 or D3 states when PME is disabled: '0' Deep Power Down is enabled in D3 state if PME is disabled. '1' Deep Power Down disabled in D3 state when PME is disabled.
Word Ah, 5:2	Reserved	These bits are reserved and should be set to 0000b.
Word Ah, 1	Standby Enable	The Standby Enable bit enables the 82551ER to enter standby mode. When this bit equals 1b, the 82551ER is able to recognize an idle state and can enter standby mode (some internal clocks are stopped for power saving purposes). If this bit equals 0b, the idle recognition circuit is disabled and the 82551ER always remains in an active state. Note: The 82551ER does not require a PCI clock signal in standby mode and always request PCI CLK using the Clockrun mechanism.
Word Ah, 0	Reserved	This bit is reserved and should be set to 0b.

Note: The IA read from the EEPROM is used by the 82551ER until an IA Setup command is issued by software. The IA defined by the IA Setup command overrides the IA read from the EEPROM.

5.6 10/100 Mbps CSMA/CD Unit

The 82551ER CSMA/CD unit implements both the IEEE 802.3 Ethernet 10 Mbps and IEEE 802.3u Fast Ethernet 100 Mbps standards. It performs all the CSMA/CD protocol functions such as transmission, reception, collision handling, etc. The 82551ER CSMA/CD unit communicates with the internal PHY unit through a standard Media Independent Interface (MII), as specified by IEEE 802.3, Chapter 22. This is a 10/100 Mbps mode in which the data stream is nibble-wide and the serial clocks run at either 25 or 2.5 MHz.

5.6.1 Full Duplex

When operating in full duplex mode the 82551ER can transmit and receive frames simultaneously. Transmission starts regardless of the state of the internal receive path. Reception starts when the internal PHY detects a valid frame on the receive differential pair of the PHY.

The 82551ER operates in either half duplex mode or full duplex mode. For proper operation, both the 82551ER CSMA/CD module and the PHY unit must be set to the same duplex mode. The CSMA duplex mode is set by the 82551ER Configure command or forced by the settings in the PHY unit's registers.

The PHY duplex mode is set either by Auto-Negotiation or, if Auto-Negotiation is disabled, by setting the full duplex bit in the Management Data Interface (MDI) Register 0, bit 8. By default, the internal PHY unit advertises full duplex ability in the Auto-Negotiation process regardless of the duplex setting of the CSMA unit. The CSMA configuration should match the result of the Auto-Negotiation.

The selection of duplex operation (full or half) and flow control is done in two levels: MAC and PHY. The MAC duplex selection is done only through the CSMA configuration mechanism (in other words, the Configure command in software).

5.6.2 Flow Control

The 82551ER supports IEEE 802.3x frame-based flow control frames in both full duplex and half duplex switched environments. The 82551ER flow control feature is not intended to be used in shared media environments.

The PHY unit's duplex and flow control enable can be selected using the NWay* Auto-Negotiation algorithm or through the Management Data Interface.

5.6.3 Address Filtering Modifications

The 82551ER can be configured to ignore one bit when checking for its Individual Address (IA) on incoming receive frames. The address bit, known as the Upper/Lower (U/L) bit, is the second least significant bit of the first byte of the IA. This bit may be used, in some cases, as a priority indication bit. When configured to do so, the 82551ER passes any frame that matches all other 47 address bits of its IA, regardless of the U/L bit value.

This configuration only affects the 82551ER specific IA and not multicast, multi-IA or broadcast address filtering. The 82551ER does not attribute any priority to frames with this bit set, it simply passes them to memory regardless of this bit.

5.6.4 Long Frame Reception

The 82551ER controller supports the reception of frames longer than 1518 bytes, including the CRC, if software sets the Long Receive OK bit in the Configuration Command. Otherwise, long frames are discarded.

5.7 Media Independent Interface (MII) Management Interface

The MII management interface allows the CPU to control the PHY unit through a control register in the 82551ER. This allows the software driver to place the PHY in specific modes such as full duplex, loopback, power down, etc., without the need for specific hardware pins to select the desired mode. This structure allows the 82551ER to query the PHY unit for status of the link. This register is the MDI Control Register and resides at offset 10h in the 82551ER CSR. (The MDI registers are described in detail in Section 11.0, “PHY Unit Registers”.) The CPU writes commands to this register and the 82551ER reads or writes the control/status parameters to the PHY unit through the MDI register. Although the 82551ER follows the MII format, the MI bus is not accessible on external pins.

6.0 Physical Layer Functional Description

6.1 100BASE-TX PHY Unit

6.1.1 100BASE-TX Transmit Clock Generation

A 25 MHz crystal or a 25 MHz oscillator is used to drive the PHY unit's X1 and X2 pins. The PHY unit derives its internal transmit digital clocks from this crystal or oscillator input. The internal Transmit Clock signal is a derivative of the 25 MHz internal clock. The accuracy of the external crystal or oscillator must be $\pm 0.005\%$ (50 PPM).

6.1.2 100BASE-TX Transmit Blocks

The transmit subsection of the PHY unit accepts nibble-wide data from the CSMA/CD unit. The transmit subsection passes data unconditionally to a 4B/5B encoder.

The 4B/5B encoder accepts nibble-wide data (4 bits) from the CSMA unit and compiles it into 5-bit-wide parallel symbols according to the IEEE 802.3u 100BASE_TX standard. Next, the symbols are scrambled to reduce electromagnetic emissions during long sequences of high-frequency data codes.

The MLT-3 (multi-level signal) encoder receives the scrambled Non-Return to Zero (NRZ) data stream from the scrambler and encodes the stream into MLT-3 for presentation to the driver. MLT-3 is similar to NRZ1 coding, but three levels are output instead of two. The three output levels are positive, negative and zero.

The transmit differential pair line drivers are implemented with digital slope controlled current buffers that meet the TP-PMD specifications. Current is sunk from an isolation transformer by the TDP and TDN pins. The 125 Mbps bit stream is typically driven onto Unshielded Twisted Pair (UTP) cable.

6.1.3 100BASE-TX Receive Blocks

The receive subsection of the PHY unit accepts 100BASE-TX MLT-3 data on the receive differential pair. Due to the advanced digital signal processing design techniques employed, the PHY unit will accurately receive valid data from Category 5 (CAT5) UTP cables of lengths well in excess of 100 meters.

The distorted MLT-3 signal at the end of the wire is restored by the equalizer. The equalizer performs adaptation based on the shape of the received signal. The clock recovery circuit uses digital signal processing to compensate for various signal jitter causes. The circuit recovers the 125 MHz clock and data and presents the data to the MLT-3 decoder.

The PHY unit first decodes the MLT-3 data; afterwards, the descrambler reproduces the 5B symbols originated in the transmitter. The data is decoded at the 4B/5B decoder. After the 4B symbols are obtained, the PHY unit outputs the receive data to the CSMA unit.

In 100BASE-TX mode, the PHY unit can detect errors in receive data in a number of ways, including link integrity failures, undetected start of stream delimiters, invalid symbols, or idles in the middle of a frame.

6.1.4 100BASE-TX Link Integrity Auto-Negotiation

The 82551ER Auto-Negotiation function automatically configures the device to the technology, media, and speed to operate with its link partner. Auto-Negotiation is described in IEEE specification 802.3u, clause 28. The PHY unit supports 10BASE-T half duplex, 10BASE-T full duplex, 100BASE-TX half duplex, and 100BASE-TX full duplex.

Speed and duplex auto-select are functions of Auto-Negotiation. However, these parameters may be manually configured through the MII management interface (MDI registers). Manual configurations override the auto-select.

6.2 10BASE-T PHY Functions

6.2.1 10BASE-T Transmit Clock Generation

The 20 MHz and 10 MHz clocks needed for 10BASE-T are synthesized from the external 25 MHz crystal or oscillator. The PHY unit provides the transmit clock and receive clock to the internal MAC at 2.5 MHz.

6.2.2 10BASE-T Transmit Blocks

After the 2.5 MHz clocked data is serialized in a 10 Mbps serial stream, the 20 MHz clock performs Manchester encoding.

Since 10BASE-T and 100BASE-TX have different filtration needs, both filters are implemented inside the chip. The PHY unit supports both technologies through one pair of TD pins and by externally sharing the same magnetics.

In 10 Mbps mode, the line drivers use a pre-distortion algorithm to improve jitter tolerance. The line drivers reduce their drive level during the second half of “wide” Manchester pulses and maintain a full drive level during narrow pulses and the first half of the wide pulses. This reduces jitter caused by overcharging the line.

6.2.3 10BASE-T Receive Blocks

The PHY unit performs Manchester decoding and timing recovery when in 10 Mbps mode. The Manchester-encoded data stream is decoded from the RD pair to separate Receive Clock and Receive Data from the differential signal. This data is transferred to the CSMA unit at 2.5 MHz/nibble.

In 10 Mbps mode, data is expected to be received on the receive differential pair after passing through isolation transformers. The input differential voltage range capability for the Twisted Pair Ethernet (TPE) receiver is greater than 585 mV and less than 3.1 V. The TPE receive buffer distinguishes valid receive data, link test pulses, and idles, according to the requirements of the 10BASE-T standard.

In 10 Mbps mode, the PHY unit can detect errors in the receive data, including voltage drops prior to the end-of-frame bit. Collision detection in 10 Mbps mode is initiated by simultaneous transmission and reception. If the PHY unit detects this condition, it asserts a collision indication to the CSMA/CD unit.

6.2.4 10BASE-T Link Integrity and Full Duplex

The link integrity in 10 Mbps works with link pulses. The PHY unit senses and differentiates those link pulses from fast link pulses and from 100BASE-TX idles. The link beat pulse is also used to determine if the receive pair polarity is reversed. If it is, the polarity is corrected internally.

The PHY unit supports 10 Mbps full duplex by disabling the collision function, the squelch test, and the carrier sense transmit function. This allows the PHY unit to transmit and receive simultaneously, achieving up to 20 Mbps network bandwidth using Auto-Negotiation. Full duplex can only be used in point-to-point connections (no shared media).

6.3 Auto-Negotiation

The PHY unit supports Auto-Negotiation, which is an automatic configuration scheme designed to manage interoperability in multifunctional LAN environments. An Auto-Negotiation capable device can detect and automatically configure its port to take maximum advantage of common modes of operation without user intervention or prior knowledge by either station. Auto-Negotiation is described in IEEE Standard 802.3u, clause 28.

6.3.1 Description

A PHY's capability is encoded by bursts of link pulses called Fast Link Pulses (FLPs). Connection is established by FLP exchange and handshake during link initialization time. After the link is established by this handshake, the native link pulse scheme resumes. A reset or management re-negotiate command (through the MDI interface) will restart the process. If the PHY unit cannot perform Auto-Negotiation, it will set this bit to 0 and determine the speed using Parallel Detection.

The PHY unit supports four technologies: 100BASE-Tx Full and Half Duplex and 10BASE-T Full and Half Duplex. Since only one technology can be used at a time (after every re-negotiate command), a prioritization scheme is used to ensure that the ability of the highest common denominator is chosen.

6.3.2 Parallel Detect and Auto-Negotiation

The PHY unit can automatically determine the speed of the link by using Parallel Detect as an alternative to Auto-Negotiation. Upon a reset, a link status fail, or a negotiate/re-negotiate command, the PHY unit inserts a long delay during which no link pulses are transmitted. This period insures that the PHY unit's link partner has gone into a Link Fail state before Auto-Negotiation or Parallel Detection begins. The PHY unit will look for both FLPs and link integrity pulses. The following diagram illustrates this process.

Figure 10. Auto-Negotiation and Parallel Detect

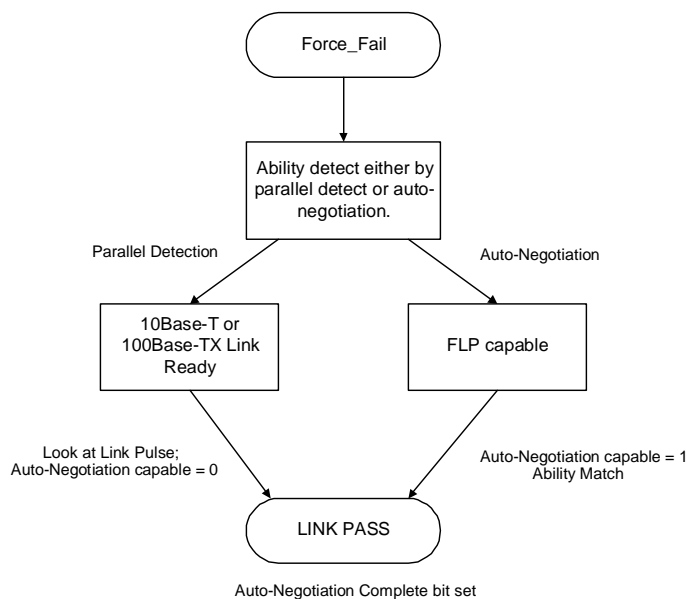

6.4 LED Description

The PHY unit supports three LED pins to indicate link status, network activity and network speed. Each pin can source 10 mA.

- **Link:** This LED is off until a valid link has been detected. After a valid link has been detected, the LED will remain on (active-low).
- **Activity:** This LED blinks on and off when activity is detected on the wire.
- **Speed:** This LED will be on if a 100BASE-TX link is detected and off if a 10BASE-T link is detected. If the link fails while in Auto-Negotiation, this LED will keep the last valid link state. If 100BASE-TX link is forced this LED will be on, regardless of the link status. This LED will be off if the 10BASE-T link is forced, regardless of the link status.

MDI register 27 in Section 11.3.12, “Register 27: PHY Unit Special Control” details the information for LED function mapping and support enhancements.

Figure 11 provides possible schematic diagrams for configurations using two and three LEDs.

Figure 11. Two and Three LED Schematic Diagram

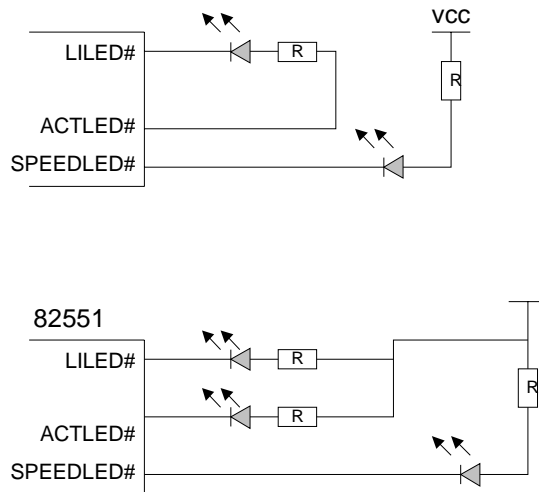



7.0 Configuration Registers

The 82551ER acts as both a master and a slave on the PCI bus. As a master, the 82551ER interacts with the system main memory to access data for transmission or deposit received data. As a slave, some 82551ER control structures are accessed by the host CPU to read or write information to the on-chip registers. The CPU also provides the 82551ER with the necessary commands and pointers that allow it to process receive and transmit data.

7.1 LAN (Ethernet) PCI Configuration Space

The 82551ER PCI configuration space is configured as 16 Dwords of Type 0 Configuration Space Header, as defined in the PCI Specification, Revision 2.1. A small section is also configured according to its device specific configuration space. The configuration space header is depicted below in Figure 12.

Figure 12. PCI Configuration Registers

Device ID		Vendor ID		00h
Status		Command		04h
Class Code			Revision ID	08h
BIST	Header Type	Latency Timer	Cache Line Size	0Ch
CSR Memory Mapped Base Address Register				10h
CSR I/O Mapped Base Address Register				14h
Flash Memory Mapped Base Address Register				18h
Reserved Base Address Register				1Ch
Reserved Base Address Register				20h
Reserved Base Address Register				24h
Reserved (PCI mode)				28h
Subsystem ID		Subsystem Vendor ID		2Ch
Expansion ROM Base Address Register				30h
Reserved			Cap_Ptr	34h
Reserved				38h
Max_Lat	Min_Gnt	Interrupt Pin	Interrupt Line	3Ch
Power Management Capabilities		Next Item Ptr	Capability ID	DCh
Reserved	Data	Power Management CSR		E0h

7.1.1 PCI Vendor ID and Device ID Registers

The Vendor ID and Device ID of the 82551ER are both read only word entities. Their values are:
 Vendor ID: 8086h
 Device ID: 1209h

7.1.2 PCI Command Register

The 82551ER Command register at word address 04h in the PCI configuration space provides control over the 82551ER's ability to generate and respond to PCI cycles. If a 0 is written to this register, the 82551ER is logically disconnected from the PCI bus for all accesses except configuration accesses. The format of this register is shown in the figure below.

Figure 13. PCI Command Register

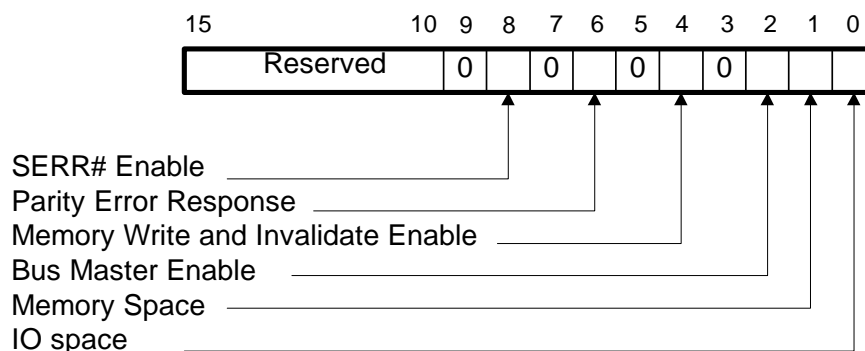

Note: Bits three, five, seven, and nine are set to 0b. The table below describes the bits of the PCI Command register.

Table 13. PCI Command Register Bits

Bits	Name	Description
15:10	Reserved	These bits are reserved and should be set to 000000b.
8	SERR# Enable	This bit controls a device's ability to enable the SERR# driver. A value of 0b disables the SERR# driver. A value of 1b enables the SERR# driver. This bit must be set to report address parity errors. In the 82551ER, this bit is configurable and has a default value of 0b.
6	Parity Error Control	This bit controls a device's response to parity errors. A value of 0b causes the device to ignore any parity errors that it detects and continue normal operation. A value of 1b causes the device to take normal action when a parity error is detected. This bit must be set to 0b after RST# is asserted. In the 82551ER, this bit is configurable and has a default value of 0b.
4	Memory Write and Invalidate Enable	This bit controls a device's ability to use the Memory Write and Invalidate Enable command. A value of 0b disables the device from using the Memory Write and Invalidate Enable command. A value of 1b enables the device to use the Memory Write and Invalidate command. In the 82551ER, this bit is configurable and has a default value of 0b.
2	Bus Master	This bit controls a device's ability to act as a master on the PCI bus. A value of 0b disables the device from generating PCI accesses. A value of 1b allows the device to behave as a bus master. In the 82551ER, this bit is configurable and has a default value of 0b.
1	Memory Space	This bit controls a device's response to the memory space accesses. A value of 0b disables the device response. A value of 1b allows the device to respond to memory space accesses. In the 82551ER, this bit is configurable and its default value of 0b.
0	I/O Space	This bit controls a device's response to the I/O space accesses. A value of 0b disables the device response. A value of 1b allows the device to respond to I/O space accesses. In the 82551ER, this bit is configurable and the default value of 0b.

7.1.3 PCI Status Register

The 82551ER Status register is used to record status information for PCI bus related events. The format of this register is shown in the figure below.

Figure 14. PCI Status Register

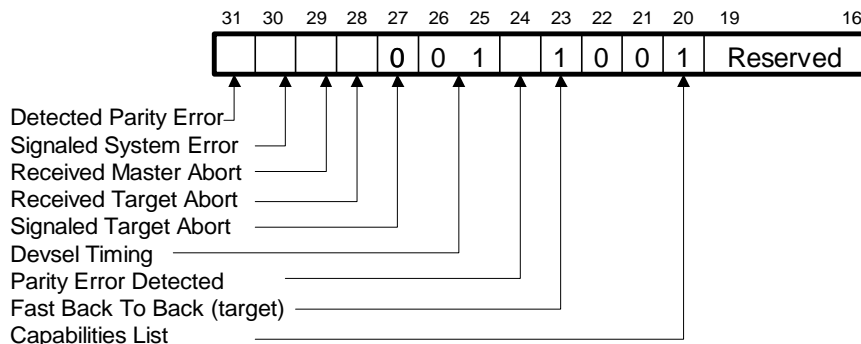

Note: Bits 21, 22, 26, and 27 are set to 0b and bits 20, 23, and 25 are set to 1b. The PCI Status register bits are described in the table below.

Table 14. PCI Status Register Bits

Bits	Name	Description
31	Detected Parity Error	This bit indicates whether a parity error is detected. This bit must be set by the device when it detects a parity error, even if parity error handling is disabled (as controlled by the Parity Error Response bit in the PCI Command register, bit 6). In the 82551ER, the initial value of the Detected Parity Error bit is 0b. This bit is set until cleared by writing a 1b.
30	Signaled System Error	This bit indicates when the device has asserted SERR#. In the 82551ER, the initial value of the Signaled System Error bit is 0b. This bit is set until cleared by writing a 1b.
29	Received Master Abort	This bit indicates whether or not a master abort has occurred. This bit must be set by the master device when its transaction is terminated with a master abort. In the 82551ER, the initial value of the Received Master Abort bit is 0b. This bit is set until cleared by writing a 1b.
28	Received Target Abort	This bit indicates that the master has received the target abort. This bit must be set by the master device when its transaction is terminated by a target abort. In the 82551ER, the initial value of the Received Target Abort bit is 0b. This bit is set until cleared by writing a 1b.
27	Signaled Target Abort	This bit indicates whether a transaction was terminated by a target abort. This bit must be set by the target device when it terminates a transaction with target abort. In the 82551ER, this bit is always set to 0b.
26:25	DEVSEL# Timing	These two bits indicate the timing of DEVSEL#: 00b - Fast 01b - Medium 10b - Slow 11b - Reserved In the 82551ER, these bits are always set to 01b, medium.

Table 14. PCI Status Register Bits

Bits	Name	Description
24	Parity Error Detected	This bit indicates whether a parity error has been detected. This bit is set to 1b when the following three conditions are met: <ol style="list-style-type: none"> 1. The bus agent asserted PERR# itself or observed PERR# asserted. 2. The agent setting the bit acted as the bus master for the operation in which the error occurred. 3. The Parity Error Response bit in the command register (bit 6) is set. In the 82551ER, the initial value of the Parity Error Detected bit is 0b. This bit is set until cleared by writing a 1b.
23	Fast Back-to-Back	This bit indicates a device's ability to accept fast back-to-back transactions when the transactions are not to the same agent. A value of 0b disables fast back-to-back ability. A value of 1b enables fast back-to-back ability. In the 82551ER, this bit is read only and is set to 1b.
20	Capabilities List	This bit indicates whether the 82551ER implements a list of new capabilities such as PCI Power Management. A value of 0b means that this function does not implement the Capabilities List. If this bit is set to 1b, the Cap_Ptr register provides an offset into the 82551ER PCI Configuration space pointing to the location of the first item in the Capabilities List. This bit is set only if the power management bit in the EEPROM is set.
19:16	Reserved	These bits are reserved and should be set to 0000b.

7.1.4 PCI Revision ID Register

The Revision ID is an 8-bit read only register. The three least significant bits of the Revision ID can be overridden by the ID and Revision ID fields in the EEPROM (Section 5.7, “Serial EEPROM Interface”). The default values of the Revision ID are:

82551ER (A-step): 0Fh

7.1.5 PCI Class Code Register

The Class Code register is read only and is used to identify the generic function of the device and, in some cases, specific register level programming interface. The register is broken into three byte size fields. The upper byte is a base class code and specifies the 82551ER as a network controller, 2h. The middle byte is a subclass code and specifies the 82551ER as an Ethernet controller, 0h. The lower byte identifies a specific register level programming interface and the 82551ER always returns a 0h in this field.

7.1.6 PCI Cache Line Size Register

In order for the 82551ER to support the Memory Write and Invalidate (MWI) command, the 82551ER must also support the Cache Line Size (CLS) register in PCI Configuration space. The register supports only cache line sizes of 8 and 16 Dwords. Any value other than 8 or 16 that is written to the register is ignored and the 82551ER does not use the MWI command. If a value other than 8 or 16 is written into the CLS register, the 82551ER returns all zeroes when the CLS register is read. The figure below illustrates the format of this register.

Figure 15. Cache Line Size Register

7	6	5	4	3	2	1	0
0	0	0	RW	RW	0	0	0

Note: Bit 3 is set to 1b only if the value 00001000b (8h) is written to this register, and bit 4 is set to 1b only if the value of 00010000b (16h) is written to this register. All other bits are read only and will return a value of 0b on read.

The BIOS is expected to write to this register. Therefore, the 82551ER driver should not write to it.

7.1.7 PCI Latency Timer

The Latency Timer register is a byte wide register. When the 82551ER is acting as a bus master, this register defines the amount of time, in PCI clock cycles, that it may own the bus.

7.1.8 PCI Header Type

The Header Type register is a byte read only register. It is equal to 00h for a single function Ethernet card and 80h for a combination Ethernet and modem card. The value of the header type is set by the EEPROM (Section 5.7, “Serial EEPROM Interface”). In a dual function card, the OS will read the next configuration registers bank at offset 100h.

7.1.9 PCI Base Address Registers

One of the most important functions for enabling superior configurability and ease of use is the ability to relocate PCI devices in address spaces. The 82551ER contains three types of Base Address Registers (BARs). Two are used for memory mapped resources, and one is used for I/O mapping. Each register is 32 bits wide. The least significant bit in the BAR determines whether it represents a memory or I/O space. The figures below show the layout of a BAR for both memory and I/O mapping. After determining this information, power-up software can map the memory and I/O controllers into available locations and proceed with system boot. In order to do this mapping in a device independent manner, the base registers for this mapping are placed in the predefined header portion of configuration space. Device drivers can then access this configuration space to determine the mapping of a particular device.

Figure 16. Base Address Register for Memory Mapping

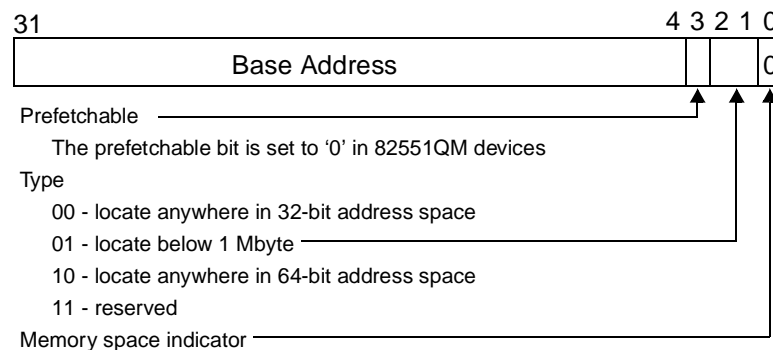
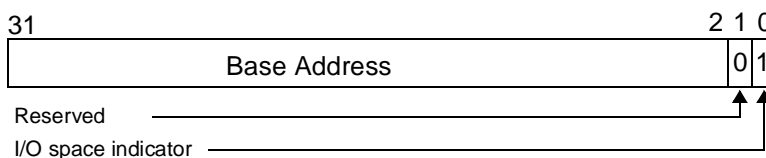

Figure 17. Base Address Register for I/O Mapping



Note: Bit 0 in all base registers is read only and used to determine whether the register maps into memory or I/O space. Base registers that map to memory space must return a 0b in bit 0. Base registers that map to I/O space must return 1b in bit 0.

Base registers that map into I/O space are always 32 bits wide with bit 0 hard-wired to a 1b, bit 1 is reserved and must return 0b on reads, and the other bits are used to map the device into I/O space.

The number of upper bits that a device actually implements depends on how much of the address space the device will respond to. For example, a device that wants a 1 Mbyte memory address space would set the most significant 12 bits of the base address register to be configurable, setting the other bits to 0b.

The 82551ER contains BARs for the Control/Status Register (CSR), Flash, and Expansion ROM.

7.1.9.1 CSR Memory Mapped Base Address Register

The 82551ER requires one BAR for memory mapping. Software determines which BAR, memory or I/O, is used to access the 82551ER CSR registers.

The memory space for the 82551ER CSR Memory Mapped BAR is 4 Kbytes. The space is marked as not prefetchable and is mapped anywhere in the 32-bit memory address space.

7.1.9.2 CSR I/O Mapped Base Address Register

The 82551ER requires one BAR for I/O mapping. Software determines which BAR, I/O or memory, is used to access the 82551ER CSR registers. The I/O space for the 82551ER CSR I/O BAR is 64 bytes.

7.1.9.3 Flash Memory Mapped Base Address Register

The Flash Memory BAR is a Dword register. The 82551ER physically supports a 128 Kbyte Flash device.

7.1.9.4 Expansion ROM Base Address Register

The Expansion ROM has a memory space of 1 Mbyte and its BAR is a Dword register that supports a 128 Kbyte memory via the 82551ER local bus. The Expansion ROM BAR can be disabled by setting the Boot Disable bit located in the EEPROM (word Ah, bit 11). If the Boot Disable bit is set, the 82551ER returns a 0b for all bits in this address register, avoiding request of memory allocation for this space.

7.1.10 Base Address Registry Summary

The preceding description of the Base Address Registers' functions are summarized in the following table:

Table 15. Base Address Register Functions

Register Name	PCI Function	PCI Window
BAR0	Memory CSR	4 Kbytes
BAR1	I/O CSR	4 Kbytes
BAR2	Flash	128 Kbytes
Expansion BAR	BootROM	1 Mbyte

7.1.11 PCI Subsystem Vendor ID and Subsystem ID Registers

The Subsystem Vendor ID field identifies the vendor of an 82551ER based solution. The Subsystem Vendor ID values are based upon the vendor's PCI Vendor ID and is controlled by the PCI Special Interest Group (SIG).

The Subsystem ID field identifies the 82551ER based specific solution implemented by the vendor indicated in the Subsystem Vendor ID field.

The 82551ER provides support for configurable Subsystem Vendor ID and Subsystem ID fields. After hardware reset is de-asserted, the 82551ER automatically reads addresses Ah through Ch of the EEPROM. The first of these 16-bit values is used for controlling various 82551ER functions. The second is the Subsystem ID value, and the third is the Subsystem Vendor ID value. Again, the default values for the Subsystem ID and Subsystem Vendor ID are 0h and 0h, respectively.

The 82551ER checks bit numbers 15, 14, and 13 in the EEPROM, word Ah and functions according to Table 16 below.

Table 16. ID Fields Programming

Signature (Bits 15:14)	ID (Bit 13)	AltID (Bit 7)	Device ID	Vendor ID	Revision ID ^a (A-0 and A-1)	Subsystem ID	Subsystem Vendor ID
11b ^b , 10b, 00b	X	X	1209h	8086h	0Fh	0000h	0000h
01b	1b	X	1209h	8086h	Word Ah, bits 10:8	Word Bh	Word Ch
01b	0b	0b	1209h	8086h	0Fh	Word Bh	Word Ch
01b	0b	0b	1209h	8086h	08h	Word Bh	Word Ch

a. The Revision ID is subject to change according to the silicon stepping.
 b. If bit 15 equals 1b, the EEPROM is invalid and the default values are used.

The above table implies that if the 82551ER detects the presence of an EEPROM (as indicated by a value of 01b in bits 15 and 14), then bit number 13 determines whether the values read from the EEPROM, words Bh and Ch, are loaded into the Subsystem ID (word Bh) and Subsystem Vendor ID (word Ch) fields. If bits 15 and 14 equal 01b and bit 13 equals 1b, the three least significant bits of the Revision ID field are programmed by bits 10:8 of the first EEPROM word, Ah.

Between the de-assertion of reset and the completion of the automatic EEPROM read, the 82551ER does not respond to any PCI configuration cycles. If the 82551ER happens to be accessed during this time, it will Retry the access. More information on Retry is provided in Section 5.2.1.1.3, “Retry Premature Accesses”.

7.1.12 Capability Pointer

The Capability Pointer is a hard-coded byte register with a value of DCh. It provides an offset within the Configuration Space for the location of the Power Management registers.

7.1.13 Interrupt Line Register

The Interrupt Line register identifies which system interrupt request line on the interrupt controller the device’s PCI interrupt request pin (as defined in the Interrupt Pin register) is routed to.

7.1.14 Interrupt Pin Register

The Interrupt Pin register is read only and defines which of the four PCI interrupt request pins, INTA# through INTD#, a PCI device is connected to. The 82551ER is connected the INTA# pin.

7.1.15 Minimum Grant Register

The Minimum Grant (Min_Gnt) register is an optional read only register for bus masters and is not applicable to non-master devices. It defines the amount of time the bus master wants to retain PCI bus ownership when it initiates a transaction. The default value of this register for the 82551ER is 08h.

7.1.16 Maximum Latency Register

The Maximum Latency (Max_Lat) register is an optional read only register for bus masters and is not applicable to non-master devices. This register defines how often a device needs to access the PCI bus. The default value of this register for the 82551ER is 18h.

7.1.17 Capability ID Register

The Capability ID is a byte register. It signifies whether the current item in the linked list is the register defined for PCI Power Management. PCI Power Management has been assigned the value of 01h. The 82551ER is fully compliant with the PCI Power Management Specification, Revision 2.2.

7.1.18 Next Item Pointer

The Next Item Pointer is a byte register. It describes the location of the next item in the 82551ER’s capability list. Since power management is the last item in the list, this register is set to 0b.

7.1.19 Power Management Capabilities Register

The Power Management Capabilities register is a word read only register. It provides information on the capabilities of the 82551ER related to power management. The 82551ER reports a value of FE21h if it is connected to an auxiliary power source and 7E21h otherwise. It indicates that the 82551ER supports wake-up in the D3 state if power is supplied, either V_{CC} or V_{AUX} .

Table 17. Power Management Capability Register

Bits	Default	Read/Write	Description
31:27	00011b (no V_{AUX}) 11111b (V_{AUX})	Read Only	PME Support. This five-bit field indicates the power states in which the 82551ER may assert PME#. The 82551ER supports wake-up in all power states if it is fed by an auxiliary power supply (V_{AUX}) and D0, D1, D2, and D3 _{hot} if it is fed by PCI power.
26	1b	Read Only	D2 Support. If this bit is set, the 82551ER supports the D2 power state.
25	1b	Read Only	D1 Support. If this bit is set, the 82551ER supports the D1 power state.
24:22	000b	Read Only	Auxiliary Current. This field reports whether the 82551ER implements the Data registers. The auxiliary power consumption is the same as the current consumption reported in the D3 state in the Data register.
21	1b	Read Only	Device Specific Initialization (DSI). The DSI bit indicates whether special initialization of this function is required (beyond the standard PCI configuration header) before the generic class device driver is able to use it. DSI is required for the 82551ER after D3-to-D0 reset.
20	0b (PCI)	Read Only	Reserved (PCI)
19	0b	Read Only	PME Clock. The 82551ER does not require a clock to generate a power management event.
18:16	010b	Read Only	Version. A value of 010b indicates that the 82551ER complies with of the PCI Power Management Specification, Revision 2.2.

7.1.20 Power Management Control/Status Register (PMCSR)

The Power Management Control/Status is a word register. It is used to determine and change the current power state of the 82551ER and control the power management interrupts in a standard manner.

Table 18. Power Management Control and Status Register

Bits	Default	Read/Write	Description
15	0b	Read/Clear	PME Status. This bit is set upon a wake-up event. It is independent of the state of the PME Enable bit. If 1b is written to this bit, the bit will be cleared. It also de-asserts the PME# signal and clears the PME status bit in the Power Management Driver Register. When the PME# signal is enabled, the PME# signal reflects the state of the PME status bit.
14:13	00b	Read Only	Data Scale. This field indicates the data register scaling factor. It equals 10b for registers zero through eight and 00b for registers nine through fifteen.
12:9	0000b	Read Only	Data Select. This field is used to select which data is reported through the Data register and Data Scale field.

Table 18. Power Management Control and Status Register

Bits	Default	Read/Write	Description
8	0b	Read Clear	PME Enable. This bit enables the 82551ER to assert PME#.
7:5	000b	Read Only	Reserved. These bits are reserved and should be set to 000b.
4	0b	Read Only	Dynamic Data. The 82551ER does not support the ability to monitor the power consumption dynamically.
3:2	00b	Read Only	Reserved. These bits are reserved and should be set to 00b.
1:0	00b	Read/Write	Power State. This 2-bit field is used to determine the current power state of the 82551ER and to set the 82551ER into a new power state. The definition of the field values is as follows. 00 - D0 01 - D1 10 - D2 11 - D3

7.1.21 Data Register

The data register is an 8-bit read only register that provides a mechanism for the 82551ER to report state dependent maximum power consumption and heat dissipation. The value reported in this register depends on the value written to the Data Select field in the PMCSR register. The power measurements defined in this register have a dynamic range of 0 to 2.55 W with 0.01 W resolution according to the Data Scale. The value in this register is hard-coded in the silicon. The structure of the data register is presented below.

Table 19. Ethernet Data Register

Data Select	Data Scale	Data Reported
0	2	D0 Power Consumption = 60 (600 mW)
1	2	D1 Power Consumption = 42 (420 mW)
2	2	D2 Power Consumption = 42 (420 mW)
3	2	D3 Power Consumption = 42 (420 mW)
4	2	D0 Power Dissipated = 60 (60 mW)
5	2	D1 Power Dissipated = 42 (420 mW)
6	2	D2 Power Dissipated = 42 (420 mW)
7	2	D3 Power Dissipated = 42 (420 mW)
8	2	Common Function Power Dissipated = 00
9-15	0	Reserved (00h)

8.0 Control/Status Registers

8.1 LAN (Ethernet) Control/Status Registers

The 82551ER's Control/Status Register (CSR) is illustrated in the figure below.

Figure 18. Control/Status Register

D31	Upper Word	D16	D15	Lower Word	D0	Offset
SCB Command Word			SCB Status Word			00h
System Control Block General Pointer						04h
PORT						08h
EEPROM Control Register			Flash Control Register			0Ch
Management Data Interface (MDI) Control Register						10h
Receive Direct Memory Access Byte Count						14h
PMDR	Flow Control Register			Reserved		18h
Reserved			General Status	General Control		1Ch
Reserved						20h
Command Block Pointer						24h
Reserved						28h
Reserved						2Ch
Function Event Register						30h
Function Event Mask Register						34h
Function Present State Register						38h
Force Event Register						3Ch

NOTE: In Figure 18 above, SCB is defined as the System Control Block of the 82551ER, and PMDR is defined as the Power Management Driver Register.

SCB Status Word: The 82551ER places the status of its Command and Receive units and interrupt indications in this register for the CPU to read.

SCB Command Word: The CPU places commands for the Command and Receive units in this register. Interrupts are also acknowledged in this register.

SCB General Pointer: The SCB General Pointer register points to various data structures in main memory depending on the current SCB Command word.

PORT Interface: The PORT interface allows the CPU to reset the 82551ER, force the 82551ER to dump information to main memory, or perform an internal self test.

Flash Control Register: The Flash Control register allows the CPU to enable writes to an external Flash.

EEPROM Control Register: The EEPROM Control register allows the CPU to read and write to an external EEPROM.

MDI Control Register: The MDI Control register allows the CPU to read and write information from the PHY unit (or an external PHY component) through the Management Data Interface.

Receive DMA Byte Count: The Receive DMA Byte Count register keeps track of how many bytes of receive data have been passed into host memory via DMA.

Flow Control Register: This register holds the flow control threshold value and indicates the flow control commands to the 82551ER.

PMDR: The Power Management Driver Register provides an indication in memory and I/O space that a wake-up interrupt has occurred.

General Control: The General Control register allows the 82551ER to enter the deep power-down state and provides the ability to disable the Clockrun functionality.

General Status: The General Status register describes the status of the 82551ER's duplex mode, speed, and link.

Function Event Mask: The Function Event Mask register masks the CSTSCHG signal assertion for specified events.

Function Present State: The Function Present State register reflects the current state of each condition that may cause a status change or interrupt.

Force Event: The Force Event register simulates the status change events for troubleshooting purposes.

8.1.1 System Control Block Status Word

The System Control Block (SCB) Status Word contains status information relating to the 82551ER's Command and Receive units.

Table 20. System Control Block Status Word

Bits	Name	Description
15	CX	Command Unit (CU) Executed. The CX bit indicates that the CU has completed executing a command with its interrupt bit set.
14	FR	Frame Received. The FR bit indicates that the Receive Unit (RU) has finished receiving a frame.
13	CNA	CU Not Active. The CNA bit is set when the CU is no longer active and in either an idle or suspended state.
12	RNR	Receive Not Ready. The RNR bit is set when the RU is not in the ready state. This may be caused by an RU Abort command, a no resources situation, or set suspend bit due to a filled Receive Frame Descriptor.
11	MDI	Management Data Interrupt. The MDI bit is set when a Management Data Interface read or write cycle has completed. The management data interrupt is enabled through the interrupt enable bit (bit 29 in the Management Data Interface Control register in the CSR).
10	SWI	Software Interrupt. The SWI bit is set when software generates an interrupt.
9	Reserved	This bit is reserved and should be set to 0b.
8	FCP	Flow Control Pause. The FCP bit is used as the flow control pause bit.

Table 20. System Control Block Status Word

Bits	Name	Description
7:6	CUS	Command Unit Status. The CUS field contains the status of the Command Unit.
5:2	RUS	Receive Unit Status. The RUS field contains the status of the Receive Unit.
1:0	Reserved	These bits are reserved and should be set to 00b.

8.1.2 System Control Block Command Word

Commands for the 82551ER’s Command and Receive units are placed in this register by the CPU.

Table 21. System Control Block Command Word

Bits	Name	Description
31:26	Specific Interrupt Mask	Specific Interrupt Mask. Setting this bit to 1b causes the 82551ER to stop generating an interrupt (in other words, de-assert the INTA# signal) on the corresponding event.
25	SI	Software Generated Interrupt. Setting this bit to 1b causes the 82551ER to generate an interrupt. Writing a 0b to this bit has no effect.
24	M	Interrupt Mask. If the Interrupt Mask bit is set to 1b, the 82551ER will not assert its INTA# pin. The M bit has higher precedence than the Specific Interrupt Mask bits and the SI bit.
23:20	CUC	Command Unit Command. This field contains the CU command.
19:16	RUC	Receive Unit Command. This field contains the RU command.

8.1.3 System Control Block General Pointer

The System Control Block (SCB) General Pointer is a 32-bit field that points to various data structures depending on the command in the CU Command or RU Command field.

8.1.4 PORT

The PORT interface allows software to perform certain control functions on the 82551ER. This field is 32 bits wide:

- Address and Data (bits 32:4)
- PORT Function Selection (bits 3:0)
 The 82551ER supports four PORT commands: Software Reset, Self-test, Selective Reset, and Dump.

8.1.5 Flash Control Register

The Flash Control Register is a 32-bit field that allows access to an external Flash device.

8.1.6 EEPROM Control Register

The EEPROM Control Register is a 32-bit field that enables a read from and a write to the external EEPROM.

8.1.7 Management Data Interface Control Register

The Management Data Interface (MDI) Control register is a 32-bit field and is used to read and write bits from the MDI.

Table 22. MDI Control Register

Bits	Description
31:30	These bits are reserved and should be set to 00b.
29	Interrupt Enable. When this bit is set to 1b by software, the 82551ER asserts an interrupt to indicate the end of an MDI cycle.
28	Ready. This bit is set to 1b by the 82551ER at the end of an MDI transaction. Software should set this bit to 0 at the same time the command is written.
27:26	Opcode. These bits define the opcode: 01 for MDI write and 10 for MDI read. All other values (00 and 11) are reserved.
25:21	PHY Address. This field of bits contains the PHY address.
20:16	PHY Register Address. This field of bits contains the PHY Register Address.
15:0	Data. In a write command, software places the data bits in this field, and the 82551ER transfers the data to the PHY unit. During a read command, the 82551ER reads these bits serially from the PHY unit, and software reads the data from this location.

8.1.8 Receive Direct Memory Access Byte Count

The Receive DMA Byte Count register keeps track of how many bytes of receive data have been passed into host memory via DMA.

8.1.9 Flow Control Register

The Flow Control Register contains the following fields:

- **Flow Control Command**
The Flow Control Command field describes the action of the flow control process (for example, pause, on, or off).
- **Flow Control Threshold**
The Flow Control Threshold field contains the threshold value (in other words, the number of free bytes in the Receive FIFO).

8.1.10 General Control Register

The General Control register is a byte register and is described below. The General Control register is used in CardBus mode only.

Table 23. General Control Register

Bits	Default	Read/Write	Description
7:2	000000b	Read Only	Reserved. These bits are reserved and should be set to 000000b.
1	0b	Read/Write	Deep Power-Down on Link Down Enable. If a 1b is written to this field, the may enter a deep power-down state (sub-3 mA) in the D2 and D3 power states while the link is down. In this state, the does not keep link integrity. This state is not supported for point-to-point connection of two end stations.
0	0b	Read/Write	Clockrun Signal Disable. If this bit is set to 1b, then the always requests the PCI clock signal. This mode can be used to overcome potential receive overruns caused by Clockrun signal latencies over 5 μ s.

8.1.11 General Status Register

The General Status register is used in CardBus mode only and is a byte register that indicates the link status of the 82551QM.

Table 24. General Status Register

Bits	Default	Read/Write	Description
7:3	00000b	Read Only	Reserved. These bits are reserved and should be set to 00000b.
2	--	Read Only	Duplex Mode. This bit indicates the wire duplex mode: full duplex (1b) or half duplex (0b).
1	--	Read Only	Speed. This bit indicates the wire speed: 100 Mbps (1b) or 10 Mbps (0b).
0	0b	Read Only	Link Status Indication. This bit indicates the status of the link: valid (1b) or invalid (0b).

8.2 Statistical Counters

The 82551ER provides information for network management statistics by providing on-chip statistical counters that count a variety of events associated with both transmit and receive. The counters are updated by the 82551ER when it completes the processing of a frame (that is, when it

has completed transmitting a frame on the link or when it has completed receiving a frame). The Statistical Counters are reported to the software on demand by issuing the Dump Statistical Counters command or Dump and Reset Statistical Counters command in the SCB Command Unit Command (CUC) field.

Table 25. Statistical Counters

ID	Counter	Description
0	Transmit Good Frames	This counter contains the number of frames that were transmitted properly on the link. It is updated only after the actual transmission on the link is completed, not when the frame was read from memory, as is done for the Transmit Command Block status.
4	Transmit Maximum Collisions (MAXCOL) Errors	This counter contains the number of frames that were not transmitted because they encountered the configured maximum number of collisions.
8	Transmit Late Collisions (LATECOL) Errors	This counter contains the number of frames that were not transmitted due to an encountered collision after the configured slot time.
12	Transmit Underrun Errors	A transmit underrun occurs because the system bus cannot keep up with the transmission. This counter contains the number of frames that were either not transmitted or retransmitted due to a transmit DMA underrun. If the 82551ER is configured to retransmit on underrun, this counter may be updated multiple times for a single frame.
16	Transmit Lost Carrier Sense (CRS)	This counter contains the number of frames that were transmitted by the 82551ER despite the fact that it detected the de-assertion of CRS during the transmission.
20	Transmit Deferred	This counter contains the number of frames that were deferred before transmission due to activity on the link.
24	Transmit Single Collisions	This counter contains the number of transmitted frames that encountered one collision.
28	Transmit Multiple Collisions	This counter contains the number of transmitted frames that encountered more than one collision.
32	Transmit Total Collisions	This counter contains the total number of collisions that were encountered while attempting to transmit. This count includes late collisions and frames that encountered MAXCOL.
36	Receive Good Frames	This counter contains the number of frames that were received properly from the link. It is updated only after the actual reception from the link is completed and all the data bytes are stored in memory.
40	Receive CRC Errors	This counter contains the number of aligned frames discarded because of a CRC error. This counter is updated, if needed, regardless of the Receive Unit state. The Receive CRC Errors counter is mutually exclusive of the Receive Alignment Errors and Receive Short Frame Errors counters.
44	Receive Alignment Errors	This counter contains the number of frames that are both misaligned (for example, CRS de-asserts on a non-octal boundary) and contain a CRC error. The counter is updated, if needed, regardless of the Receive Unit state. The Receive Alignment Errors counter is mutually exclusive of the Receive CRC Errors and Receive Short Frame Errors counters.

Table 25. Statistical Counters

ID	Counter	Description
48	Receive Resource Errors	This counter contains the number of good frames discarded due to unavailability of resources. Frames intended for a host whose Receive Unit is in the No Resources state fall into this category. If the 82551ER is configured to Save Bad Frames and the status of the received frame indicates that it is a bad frame, the Receive Resource Errors counter is not updated.
52	Receive Overrun Errors	This counter contains the number of frames known to be lost because the local system bus was not available. If the traffic problem persists for more than one frame, the frames that follow the first are also lost; however, because there is no lost frame indicator, they are not counted.
56	Receive Collision Detect (CDT)	This counter contains the number of frames that encountered collisions during frame reception.
60	Receive Short Frame Errors	This counter contains the number of received frames that are shorter than the minimum frame length. The Receive Short Frame Errors counter is mutually exclusive to the Receive Alignment Errors and Receive CRC Errors counters. A short frame will always increment only the Receive Short Frame Errors counter.
64	Flow Control Transmit Pause	This counter contains the number of Flow Control frames transmitted by the 82551ER. This count includes both the Xoff frames transmitted and Xon (PAUSE(0)) frames transmitted.
68	Flow Control Receive Pause	This counter contains the number of Flow Control frames received by the 82551ER. This count includes both the Xoff frames received and Xon (PAUSE(0)) frames received.
72	Flow Control Receive Unsupported	This counter contains the number of MAC Control frames received by the 82551ER that are not Flow Control Pause frames. These frames are valid MAC control frames that have the predefined MAC control Type value and a valid address but has an unsupported opcode.

The Statistical Counters are initially set to zero by the 82551ER after reset. They cannot be preset to anything other than zero. The 82551ER increments the counters by internally reading them, incrementing them and writing them back. This process is invisible to the CPU and PCI bus. In addition, the counters adhere to the following rules:

- The counters are wrap-around counters. After reaching FFFFFFFFh the counters wrap around to 0.
- The 82551ER updates the required counters for each frame. It is possible for more than one counter to be updated as multiple errors can occur in a single frame.
- The counters are 32 bits wide and their behavior is fully compatible with the IEEE 802.1 standard. The 82551ER supports all mandatory and recommend statistics functions through the status of the receive header and directly through these Statistical Counters.

The CPU can access the counters by issuing a Dump Statistical Counters SCB command. This provides a “snapshot”, in main memory, of the internal 82551ER statistical counters. The 82551ER supports 19 counters. The dump could consist of either 16 or 19 counters, depending on the status of the Extended Statistics Counters configuration bits in the Configuration command.



9.0 PHY Unit Registers

The 82551ER provides status and accepts management information via the Management Data Interface (MDI) within the CSR space.

Acronyms mentioned in the registers are defined as follows:

- SC - self cleared
- RO - read only
- E - EEPROM setting affects content
- LL - latch low
- LH - latch high

9.1 MDI Registers 0 - 7

9.1.1 Register 0: Control Register

Table 26. Register 0: Control

Bit(s)	Name	Description	Default	R/W
15	Reset	This bit sets the status and control register of the PHY to their default states and is self-clearing. The PHY returns a value of one until the reset process has completed and accepts a read or write transaction. 1 = PHY Reset	0	RW SC
14	Loopback	This bit enables loopback of transmit data nibbles from the TXD[3:0] signals to the receive data path. The PHY unit's receive circuitry is isolated from the network. Note that this may cause the descrambler to lose synchronization and produce 560 nanoseconds of "dead time." Note also that the loopback configuration bit takes priority over the Loopback MDI bit. 1 = Loopback enabled 0 = Loopback disabled (Normal operation)	0	RW
13	Speed Selection	This bit controls speed when Auto-Negotiation is disabled and is valid on read when Auto-Negotiation is disabled. 1 = 100 Mbps 0 = 10 Mbps	1	RW
12	Auto-Negotiation Enable	This bit enables Auto-Negotiation. Bits 13 and 8, Speed Selection and Duplex Mode, respectively, are ignored when Auto-Negotiation is enabled. 1 = Auto-Negotiation enabled 0 = Auto-Negotiation disabled	1	RW

Table 26. Register 0: Control

Bit(s)	Name	Description	Default	R/W
11	Power-Down	This bit sets the PHY unit into a low power mode. In low power mode, the PHY unit consumes no more than 30 mA. 1 = Power-Down enabled 0 = Power-Down disabled (Normal operation)	0	RW
10	Reserved	This bit is reserved and should be set to 0b.	0	RW
9	Restart Auto-Negotiation	This bit restarts the Auto-Negotiation process and is self-clearing. 1 = Restart Auto-Negotiation process	0	RW SC
8	Duplex Mode	This bit controls the duplex mode when Auto-Negotiation is disabled. If the PHY reports that it is only able to operate in one duplex mode, the value of this bit shall correspond to the mode which the PHY can operate. When the PHY is placed in Loopback mode, the behavior of the PHY shall not be affected by the status of this bit, bit 8. 1 = Full Duplex 0 = Half Duplex	0	RW
7	Collision Test	This bit will force a collision in response to the assertion of the transmit enable signal. 1 = Force COL 0 = Do not force COL	0	RW
6:0	Reserved	These bits are reserved and should be set to 0000000b.	0	RW

9.1.2 Register 1: Status Register

Table 27. Register 1: Status

Bit(s)	Name	Description	Default	R/W
15	Reserved	This bit is reserved and should be set to 0b.	0	RO E
14	100BASE-TX Full Duplex	1 = PHY able to perform full duplex 100BASE-TX	1	RO
13	100 Mbps Half Duplex	1 = PHY able to perform half duplex 100BASE-TX	1	RO
12	10 Mbps Full Duplex	1 = PHY able to operate at 10Mbps in full duplex mode	1	RO
11	10 Mbps Half Duplex	1 = PHY able to operate at 10 Mbps in half duplex mode	1	RO
10:7	Reserved	These bits are reserved and should be set to 0000b.	0	RO
6	Management Frames Preamble Suppression	0 = PHY will not accept management frames with preamble suppressed	0	RO
5	Auto-Negotiation Complete	1 = Auto-Negotiation process completed 0 = Auto-Negotiation process has not completed	0	RO
4	Remote Fault	0 = No remote fault condition detected	0	RO

Table 27. Register 1: Status

Bit(s)	Name	Description	Default	R/W
3	Auto-Negotiation Ability	1 = PHY is able to perform Auto-Negotiation	1	RO
2	Link Status	1 = Valid link has been established 0 = Invalid link detected	0	RO LL
1	Jabber Detect	1 = Jabber condition detected 0 = No jabber condition detected	0	RO LH
0	Extended Capability	1 = Extended register capabilities enabled	1	RO

9.1.3 Register 2: PHY Identifier Register

Table 28. Register 2: PHY Identifier

Bit(s)	Name	Description	Default	R/W
15:0	PHY ID (high byte)	Value: 02A8h	--	RO

9.1.4 Register 3: PHY Identifier Register

Table 29. Register 3 PHY Identifier

Bit(s)	Name	Description	Default	R/W
15:0	PHY ID (low byte)	Value: 0154h	--	RO

9.1.5 Register 4: Auto-Negotiation Advertisement Register

Table 30. Register 4: Auto-Negotiation Advertisement

Bit(s)	Name	Description	Default	R/W
15	Next Page	Constant 0 = Transmitting primary capability data page	0	RO
14	Reserved	This bit is reserved and should be set to 0b.	0	RO
13	Remote Fault	1 = Indicate link partner's remote fault 0 = No remote fault	0	RW
12:5	Technology Ability Field	Technology Ability Field is an 8-bit field containing information indicating supported technologies specific to the selector field value.	00101111	RW
4:0	Selector Field	The Selector Field is a 5-bit field identifying the type of message to be sent via Auto-Negotiation. This field is read only in the 82551ER and contains a value of 00001b, IEEE Standard 802.3.	00001	RO

9.1.6 Register 5: Auto-Negotiation Link Partner Ability Register

Table 31. Auto-Negotiation Link Partner Ability

Bit(s)	Name	Description	Default	R/W
15	Next Page	This bit reflects the PHY's link partner's Auto-Negotiation ability.	--	RO
14	Acknowledge	This bit is used to indicate that the 82551ER's PHY unit has successfully received its link partner's Auto-Negotiation advertising ability.	--	RO
13	Remote Fault	This bit reflects the PHY's link partner's Auto-Negotiation ability.	--	RO
12:5	Technology Ability Field	This bit reflects the PHY's link partner's Auto-Negotiation ability.	--	RO
4:0	Selector Field	This bit reflects the PHY's link partner's Auto-Negotiation ability.	--	RO

9.1.7 Register 6: Auto-Negotiation Expansion Register

Table 32. Register 6: Auto-Negotiation Expansion

Bit(s)	Name	Description	Default	R/W
15:5	Reserved	These bits are reserved and should be set to 0b.	0	RO
4	Parallel Detection Fault	1 = Fault detected via parallel detection (multiple link fault occurred) 0 = No fault detected via parallel detection This bit will self-clear on read	0	RO SC LH
3	Link Partner Next page Able	1 = Link Partner is Next Page able 0 = Link Partner is not Next Page able	0	RO
2	Next Page Able	1 = Local drive is Next Page able 0 = Local drive is not Next Page able	0	RO
1	Page Received	1 = New Page received 0 = New Page not received This bit will self-clear on read.	0	RO SC LH
0	Link Partner Auto-Negotiation Able	1 = Link Partner is Auto-Negotiation able 0 = Link Partner is not Auto-Negotiation able	0	RO

9.2 MDI Registers 8 - 15

Registers eight through fifteen are reserved for IEEE.

9.3 MDI Register 16 - 31

9.3.1 Register 16: PHY Unit Status and Control Register

Table 33. PHY Unit Status and Control

Bit(s)	Name	Description	Default	R/W
15:14	Reserved	These bits are reserved and should be set to 00b	00	RW
13	Carrier Sense Disconnect Control	This bit enables the disconnect function. 1 = Disconnect function enabled 0 = Disconnect function disabled	0	RW
12	Transmit Flow Control Disable	This bit enables Transmit Flow Control 1 = Transmit Flow Control enabled 0 = Transmit Flow Control disabled	0	RW
11	Receive De-Serializer In-Sync Indication	This bit indicates receipt status of the 100BASE-TX receive de-serializer in-sync.	--	RO
10	100BASE-TX Power-Down	This bit indicates the power state of 100BASE-TX PHY unit. 1 = Power-Down 0 = Normal operation	1	RO
9	10BASE-T Power-Down	This bit indicates the power state of 100BASE-TX PHY unit. 1 = Power-Down 0 = Normal operation	1	RO
8	Polarity	This bit indicates 10BASE-T polarity. 1 = Reverse polarity 0 = Normal polarity	--	RO
7:2	Reserved	These bits are reserved and should be set to 0B.	000000	RO
1	Speed	This bit indicates the Auto-Negotiation result. 1 = 100 Mbps 0 = 10 Mbps	--	RO
0	Duplex Mode	This bit indicates the Auto-Negotiation result. 1 = Full Duplex 0 = Half Duplex	--	RO

9.3.2 Register 17: PHY Unit Special Control Register

Table 34. Register 17: PHY Unit Special Control

Bit(s)	Name	Description	Default	R/W
15	Scrambler By-pass	1 = By-pass Scrambler 0 = Normal operations	0	RW
14	By-pass 4B/5B	1 = 4 bit to 5 bit by-pass 0 = Normal operation	0	RW
13	Force Transmit H-Pattern	1 = Force transmit H-pattern 0 = Normal operation	0	RW

Table 34. Register 17: PHY Unit Special Control

Bit(s)	Name	Description	Default	R/W
12	Force 34 Transmit Pattern	1 = Force 34 transmit pattern 0 = Normal operation	0	RW
11	Good Link	1 = 100BASE-TX link good 0 = Normal operation	0	RW
10	Reserved	This bit is reserved and should be set to 0b.	0	RW
9	Transmit Carrier Sense Disable	1 = Transmit Carrier Sense disabled 0 = Transmit Carrier Sense enabled	0	RW
8	Disable Dynamic Power-Down	1 = Dynamic Power-Down disabled 0 = Dynamic Power-Down enabled (normal)	0	RW
7	Auto-Negotiation Loopback	1 = Auto-Negotiation loopback 0 = Auto-Negotiation normal mode	0	RW
6	MDI Tri-State	1 = MDI Tri-state (transmit driver tri-states) 0 = Normal operation	0	RW
5	Filter By-pass	1 = By-pass filter 0 = Normal filter operation	0	RW
4	Auto Polarity Disable	1 = Auto Polarity disabled 0 = Normal polarity operation	0	RW
3	Squelch Disable	1 = 10BASE-T squelch test disable 0 = Normal squelch operation	0	RW
2	Extended Squelch	1 = 10BASE-T Extended Squelch control enabled 0 = 10BASE-T Extended Squelch control disabled	0	RW
1	Link Integrity Disable	1 = Link disabled 0 = Normal Link Integrity operation	0	RW
0	Jabber Function Disable	1 = Jabber disabled 0 = Normal Jabber operation	0	RW

9.3.3 Register 18: PHY Address Register

Table 35. Register 18: PHY Address

Bit(s)	Name	Description	Default	R/W
15:5	Reserved	These bits are reserved and should be set to a constant '0'	0	RO
4:0	PHY Address	These bits are set to the PHY's address, 00001b.	1	RO

9.3.4 Register 19: 100BASE-TX Receive False Carrier Counter

Table 36. Register 19: 100BASE-TX Receive False Carrier Counter

Bit(s)	Name	Description	Default	R/W
15:0	Receive False Carrier	These bits are used for the false carrier counter.	--	RO SC

9.3.5 Register 20: 100BASE-TX Receive Disconnect Counter

Table 37. Register 20: 100BASE-TX Receive Disconnect Counter

Bit(s)	Name	Description	Default	R/W
15:0	Disconnect Event	This field contains a 16-bit counter that increments for each disconnect event. The counter freezes when full and self-clears on read	--	RO SC

9.3.6 Register 21: 100BASE-TX Receive Error Frame Counter

Table 38. Register 21: 100BASE-TX Receive Error Frame Counter

Bit(s)	Name	Description	Default	R/W
15:0	Receive Error Frame	This field contains a 16-bit counter that increments once per frame for any receive error condition (such as a symbol error or premature end of frame) in that frame. The counter freezes when full and self-clears on read.	--	RO SC

9.3.7 Register 22: Receive Symbol Error Counter

Table 39. Register 22: Receive Symbol Error Counter

Bit(s)	Name	Description	Default	R/W
15:0	Symbol Error Counter	This field contains a 16-bit counter that increments for each symbol error. The counter freezes when full and self-clears on read. In a frame with a bad symbol, each sequential six bad symbols count as one.	--	RO SC

9.3.8 Register 23: 100BASE-TX Receive Premature End of Frame Error Counter

Table 40. Register 23: 100BASE-TX Receive Premature End of Frame Error Counter

Bit(s)	Name	Description	Default	R/W
15:0	Premature End of Frame	This field contains a 16-bit counter that increments for each premature end of frame event. The counter freezes when full and self-clears on read.	--	RO SC

9.3.9 Register 24: 10BASE-T Receive End of Frame Error Counter

Table 41. Register 24: 10BASE-T Receive End of Frame Error Counter

Bit(s)	Name	Description	Default	R/W
15:0	End of Frame Counter	This is a 16-bit counter that increments for each end of frame error event. The counter freezes when full and self-clears on read.	--	RO SC

9.3.10 Register 25: 10BASE-T Transmit Jabber Detect Counter

Table 42. Register 25: 10BASE-T Transmit Jabber Detect Counter

Bit(s)	Name	Description	Default	R/W
15:0	Jabber Detect Counter	This is a 16-bit counter that increments for each jabber detection event. The counter freezes when full and self-clears on read.	--	RO SC

9.3.11 Register 26: Equalizer Control and Status Register

Table 43. Register 26: Equalizer Control and Status

Bit(s)	Name	Description	Default	R/W
15:0	RFU	Reserved for Future Use	--	RW

9.3.12 Register 27: PHY Unit Special Control Register

Table 44. Register 27: PHY Unit Special Control

Bit(s)	Name	Description	Default	R/W																											
15:3	Reserved	These bits are reserved and should be set to 0b.	0	RW																											
2:0	LED Switch Control	<table border="1"> <thead> <tr> <th>Value</th> <th>ACTLED</th> <th>LILED</th> </tr> </thead> <tbody> <tr> <td>000</td> <td>Activity</td> <td>Link</td> </tr> <tr> <td>001</td> <td>Speed</td> <td>Collision</td> </tr> <tr> <td>010</td> <td>Speed</td> <td>Link</td> </tr> <tr> <td>011</td> <td>Activity</td> <td>Collision</td> </tr> <tr> <td>100</td> <td>Off</td> <td>Off</td> </tr> <tr> <td>101</td> <td>Off</td> <td>On</td> </tr> <tr> <td>110</td> <td>On</td> <td>Off</td> </tr> <tr> <td>111</td> <td>On</td> <td>On</td> </tr> </tbody> </table>	Value	ACTLED	LILED	000	Activity	Link	001	Speed	Collision	010	Speed	Link	011	Activity	Collision	100	Off	Off	101	Off	On	110	On	Off	111	On	On	000	RW
Value	ACTLED	LILED																													
000	Activity	Link																													
001	Speed	Collision																													
010	Speed	Link																													
011	Activity	Collision																													
100	Off	Off																													
101	Off	On																													
110	On	Off																													
111	On	On																													

9.3.13 Register 28: Reserved

This register is reserved and should not be used.

9.3.14 Register 29: Hardware Integrity Control Register

Table 45. Register 29: Hardware Integrity Control

Bit(s)	Name	Description	Default	R/W
15	HWI Enable	This bit enables the HWI feature causing the PHY unit to enter HWI test mode. 1 = HWI enabled 0 = HWI disabled	0	RW
14	Ability Check	This bit reports the results of the HWI ability check and is valid 100 μ s after the HWI Enabled bit (bit 15 of this register) is set (1b). 1 = Test passed 0 = Test failed (HWI ability not detected)		RO
13	Test Execute	When this bit is set, the PHY unit launches test pulses on the wire to determine the distance to the cable's high or low impedance point. 1 = Execute test 0 = Do not execute test		WO
12:11	Reserved	These bits are reserved and should be set to 0b.	00	RO
10:9	LowZ/HighZ	This field of bits indicates either a short (Low Z) or open (high Z) on the line. It is valid 100 μ s after the Test Execute bit (bit 13 of this register) is set. 1 = Short (low Z) 0 = Open (high Z)		RO
8:0	Distance	These bits define the distance to the short or open in the cable and are valid 100 μ s after the Test Execute bit (bit 13 of this register) is set. The distance is defined in granularities of 80 cm (35 inches).		RO



10.0 Electrical and Timing Specifications

Note: This section contains information on products in sampling and early production phase of development. Do not finalize a design with this information. Revised information will be published when the product becomes available.

10.1 Absolute Maximum Ratings

Maximum ratings are listed below:

Case Temperature under Bias	0 C to 85 C
Storage Temperature	-65 C to 140 C
Outputs and Supply Voltages (except PCI)	-0.5 V to 5.0 V
PCI Output Voltages	-0.50 V to 5.25 V
Transmit Data Output Voltage	-0.5 V to 8.0 V
Input Voltages (except PCI)	-1.0 V to 5.0 V
PCI Input Voltages	-0.5 V to 6.0 V

Stresses above the listed absolute maximum ratings may cause permanent damage to the 82551ER device. This is a stress rating only and functional operations of the device at these or any other conditions above those indicated in the operational sections of this specification is not implied. Exposure to absolute maximum rating conditions for extended periods may affect device reliability.

10.2 DC Specifications

Table 46. General DC Specifications

Symbol	Parameter	Condition	Min	Typical	Max	Units	Notes
V _{CC}	Supply Voltage		3.0	3.3	3.6	V	
V _{IO}	Periphery Clamp Voltage	PCI	4.75	5.0	5.25	V	1

Table 46. General DC Specifications

I_{CC}	Power Supply (10BASE-T)	D0 _a 10BASE-T full function	85	100	mA	2
		D1, D2, D3 _{hot} 10BASE-T wake-up enabled	65	75	mA	
		D3 _{cold} 10BASE-T wake-up enabled	40	50	mA	
		D3 _{cold} 10BASE-T wake-up disabled	1.5	2.0	mA	
	Power Supply (100BASE-TX)	D0 _a 100BASE-TX full function	135	155	mA	2
		D1, D2, D3 _{hot} 100BASE-TX wake-up enabled	110	125	mA	
		D3 _{cold} 100BASE-TX wake-up enabled	95	110	mA	
		D3 _{cold} 100BASE-TX wake-up disabled	1.5	2.0	mA	

NOTES:

1. V_{IO} should be $5\text{ V} \pm 5\%$ in any PCI environment (either 5 V or 3.3 V signaling).
2. Typical current consumption is in nominal operating conditions ($V_{CC} = 3.3\text{ V}$) and average link activity. Maximum current consumption is in maximum V_{CC} and maximum link activity.

The 82551ER supports PCI interface standards. In the PCI mode, it is five volts tolerant and supports both 5 V and 3.3 V signaling environments.

Table 47. PCI Interface DC Specifications

Symbol	Parameter	Condition	Min	Max	Units	Notes
V_{IHP}	Input High Voltage		$0.475V_{CC}$	$V_{IO} + 0.5$	V	
V_{ILP}	Input Low Voltage		-0.5	$0.325V_{CC}$	V	
V_{IPUP}	Input Pull-up Voltage		$0.7V_{CC}$		V	1
V_{IPDP}	Input Pull-down Voltage			$0.2V_{CC}$	V	1
I_{ILP}	Input Leakage Current	$0 < V_{IN} < V_{CC}$		± 10	μA	2
V_{OHP}	Output High Voltage	$I_{out} = -2\text{ mA}$	2.4		V	PCI
		$I_{out} = -500\ \mu\text{A}$	$0.9V_{CC}$		V	
V_{OLP}	Output Low Voltage	$I_{out} = 3\text{ mA}, 6\text{ mA}$		0.55	V	3, PCI
		$I_{out} = 1500\ \mu\text{A}$		$0.1V_{CC}$	V	
C_{INP}	Input Pin Capacitance			10	pF	4
C_{CLKP}	CLK Pin Capacitance		5	12	pF	4
C_{IDSEL}	IDSEL Pin Capacitance			8	pF	4
L_{PINP}	Pin Inductance			20	nH	4
I_{OFFPME}	PME# Input Leakage Current	$V_O < V_{IO}$		1	mA	5

NOTES:

1. These values are only applicable in 3.3 V signaling environments. Outside of this limit the input buffer must consume its minimum current.

2. Input leakage currents include high-Z output leakage for all bidirectional buffers with tristate outputs.
3. Signals without pull-up resistors have 3 mA low output current; and signals requiring pull-up resistors, 6 mA. The signals requiring pull-up resistors include: FRAME#, TRDY#, IRDY#, DEVSEL#, STOP#, SERR# and PERR#.
4. This value is characterized but not tested.
5. This input leakage current is the maximum allowable leakage into the PME# open drain driver when power is removed from V_{CC} of the component. This assumes that no event has occurred to cause the device to assertion of PME#.

Table 48. Flash/EEPROM Interface DC Specifications

Symbol	Parameter	Condition	Min	Max	Units	Notes
V_{IHL}	Input High Voltage		2.0	$V_{CC} + 0.5$	V	
V_{ILL}	Input Low Voltage		-0.5	0.8	V	
I_{ILL}	Input Low Leakage Current	$0 < V_{IN} < V_{CC}$		± 20	μA	
V_{OHL}	Output High Voltage	$I_{out} = -1 \text{ mA}$	2.4		V	
V_{OLL}	Output Low Voltage	$I_{out} = 2 \text{ mA}$		0.4	V	
C_{INL}	Input Pin Capacitance			10	pF	1

NOTE:

1. This value is characterized but not tested.

Table 49. LED Voltage/Current Characteristics

Symbol	Parameter	Condition	Min	Typical	Max	Units	Notes
V_{OHLED}	Output High Voltage	$I_{out} = -10 \text{ mA}$	2.4			V	
V_{OLLED}	Output Low Voltage	$I_{out} = 10 \text{ mA}$			0.7	V	

Table 50. 100BASE-TX Voltage/Current Characteristics

Symbol	Parameter	Condition	Min	Typical	Max	Units	Notes
R_{ID100}	Input Differential Impedance	DC	10			K Ω	
V_{IDA100}	Input Differential Accept Peak Voltage		± 500			mV	
V_{IDR100}	Input Differential Reject Peak Voltage				± 100	mV	
V_{ICM100}	Input Common Mode Voltage			$V_{CC}/2$		V	
V_{OD100}	Output Differential Peak Voltage		0.95	1.00	1.05	V	
I_{CCT100}	Line Driver Supply Peak Current	$R_{BIAS100} = 619 \Omega$		20		mA	1, 2

NOTES:

1. Current is measured on all V_{CC} pins ($V_{CC} = 3.3 \text{ V}$).

- Transmitter peak current is attained by dividing the measured maximum differential output peak voltage by the load resistance value.

Figure 19. RBIAS100 Resistance Versus Transmitter Current

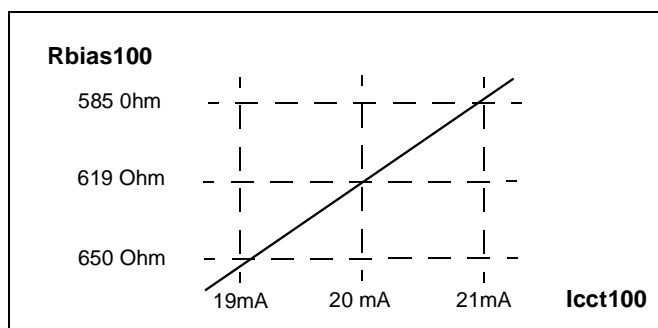

Table 51. 10BASE-T Voltage/Current Characteristics

Symbol	Parameter	Condition	Min	Typical	Max	Units	Notes
R _{ID10}	Input Differential Impedance	10 MHz	10			KΩ	
V _{IDA10}	Input Differential Accept Peak Voltage	5 MHz ≤ f ≤ 10 MHz	±585	±440	±3100	mV	
V _{IDR10}	Input Differential Reject Peak Voltage	5 MHz ≤ f ≤ 10 MHz	0	±440	±300	mV	
V _{ICM10}	Input Common Mode Voltage			V _{CC} /2		V	
V _{OD10}	Output Differential Peak Voltage	R _L = 100 Ω	2.2		2.8	V	
I _{CCT10}	Line Driver Supply Peak Current	R _{BIA10} = 549 Ω		50		mA	1, 2

NOTES:

- Current is measured on all V_{CC} pins (V_{CC} = 3.3 V).
- Transmitter peak current is attained by dividing the measured maximum differential output peak voltage by the load resistance value.

Figure 20. RBIAS10 Resistance Versus Transmitter Current

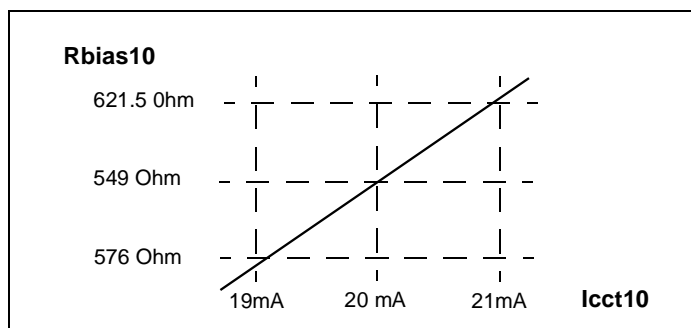

10.3 AC Specifications

Table 52. AC Specifications for PCI Signaling

Symbol	Parameter	Condition	Min	Max	Units	Notes
$I_{OH(AC)}$	Switching Current High	$0 < V_{OUT} \leq 1.4$	-44		mA	1
		$1.4 < V_{OUT} < 0.9V_{CC}$	$-17.1(V_{CC} - V_{OUT})$		mA	1
		$0.7V_{CC} < V_{OUT} < V_{CC}$		Eqn A	mA	2
	(Test Point)	$V_{OUT} = 0.7V_{CC}$		$-32V_{CC}$	mA	2
$I_{OL(AC)}$	Switching Current Low	$V_{OUT} \geq 2.2$	95		mA	1
		$2.2 > V_{OUT} > 0.1V_{CC}$	$V_{OUT}/0.023$		mA	1
		$0.18V_{CC} > V_{OUT} > 0$		Eqn B	mA	2
	(Test Point)	$V_{OUT} = 0.18V_{CC}$		$38V_{CC}$	mA	2
I_{CL}	Low Clamp Current	$-3 < V_{IN} \leq -1$	$-25 + (V_{IN} + 1)/0.015$		mA	3
I_{CH}	High Clamp Current	$V_{CC} + 4 > V_{IN} \geq V_{CC} + 1$	$25 + (V_{IN} - V_{CC} - 1)/0.015$		mA	3
$slew_{RP}$	PCI Output Rise Slew Rate	0.4 V to 2.4 V	1	4	V/ns	
$slew_{FP}$	PCI Output Fall Slew Rate	2.4 V to 0.4 V	1	4	V/ns	

NOTES:

- Switching Current High specifications are not relevant to PME#, SERR#, or INTA#, which are open drain outputs.
- Maximum current requirements will be met as drivers pull beyond the first step voltage (AC drive point). Equations defining these maximums (A and B) are provided. To facilitate component testing, a maximum current test point is defined for each side of the output driver.

Equation A. $I_{OH} = (98/V_{CC}) \cdot (V_{out} - V_{CC}) \cdot (V_{out} + 0.4V_{CC})$, for $V_{CC} > V_{out} > 0.7V_{CC}$

Equation B. $I_{OL} = (256/V_{CC}) \cdot (V_{out}) \cdot (V_{CC} - V_{out})$, for $0 < V_{out} < 0.18V_{CC}$

10.4 Timing Specifications

10.4.1 Clocks Specifications

10.4.1.1 PCI Clock Specifications

The 82551ER uses the PCI Clock signal directly. Figure 21 shows the clock waveform and required measurement points for the PCI Clock signal. Table 53 summarizes the PCI Clock specifications.

Figure 21. PCI Clock Waveform

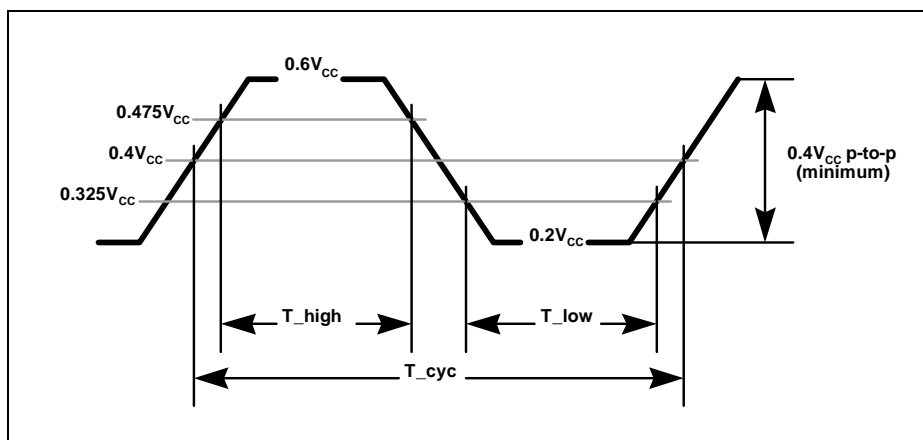

Table 53. PCI Clock Specifications

	Symbol	Parameter	Min	Max	Units	Notes
T1	T_{cyc}	CLK Cycle Time	30		ns	1
T2	T_{high}	CLK High Time	11		ns	
T3	T_{low}	CLK Low Time	11		ns	
T4	T_{slew}	CLK Slew Rate	1	4	V/ns	2

NOTES:

1. The 82551ER will work with any PCI clock frequency up to 33 MHz.
2. Rise and fall times are specified in terms of the edge rate measured in V/ns. This slew rate is met across the minimum peak-to-peak portion of the clock waveform as shown in Figure 21.

10.4.1.2 X1 Specifications

X1 serves as a signal input from an external crystal or oscillator. Table 54 defines the 82551ER requirements from this signal.

Table 54. X1 Clock Specifications

	Symbol	Parameter	Min	Typical	Max	Units	Notes
T8	$Tx1_{dc}$	X1 Duty Cycle	40%		60%		
T9	$Tx1_{pr}$	X1 Period		40		ns	$\pm 50PPM$

10.4.2 Timing Parameters

10.4.2.1 Measurement and Test Conditions

Figure 22, Figure 23, and Table 55 define the conditions under which timing measurements are done. The component test guarantees that all timings are met with minimum clock slew rate (slowest edge) and voltage swing. The design must guarantee that minimum timings are also met with maximum clock slew rate (fastest edge) and voltage swing. In addition, the design must guarantee proper input operation for input voltage swings and slew rates that exceed the specified test conditions.

Figure 22. Output Timing Measurement Conditions

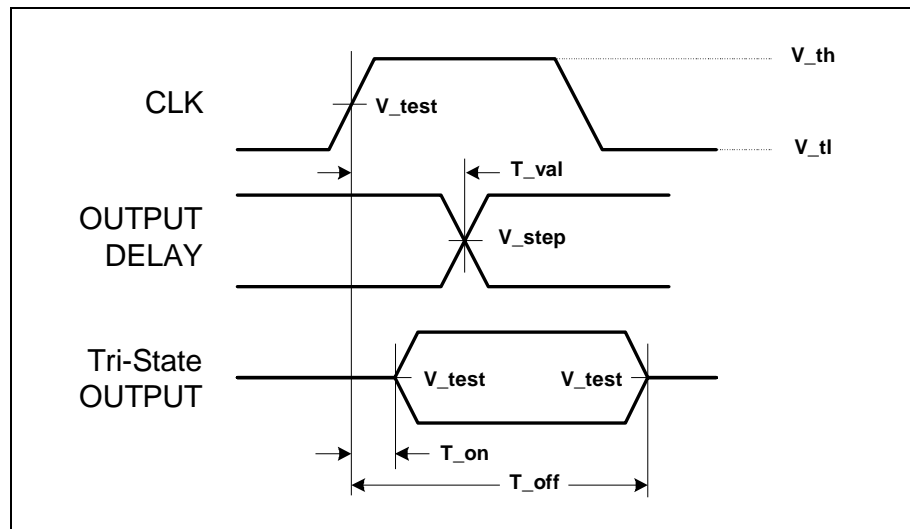

Figure 23. Input Timing Measurement Conditions

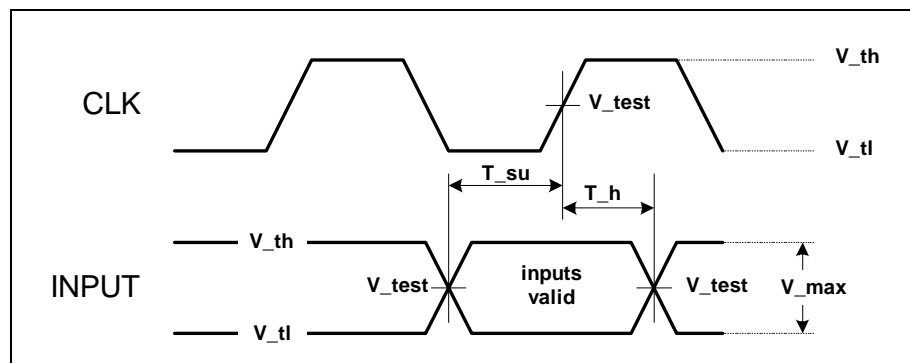

Table 55. Measure and Test Condition Parameters

Symbol	PCI Level	CardBus Level	Units	Notes
V_{th}	$0.6V_{CC}$	$0.6V_{CC}$	V	
V_{tl}	$0.2V_{CC}$	$0.2V_{CC}$	V	

Table 55. Measure and Test Condition Parameters

V_{test}	$0.4V_{CC}$	$0.4V_{CC}$	V	
V_{step} (rising edge)	$0.285V_{CC}$	$0.325V_{CC}$	V	Min Delay
		$0.475V_{CC}$	V	Max Delay
V_{step} (falling edge)	$0.615V_{CC}$	$0.475V_{CC}$	V	Min Delay
		$0.325V_{CC}$	V	Max Delay
V_{max}	$0.4V_{CC}$	$0.4V_{CC}$	V	
Input Signal Edge Rate	1	1	V/ns	

NOTE: Input test is done with $0.1V_{CC}$ overdrive. V_{max} specifies the maximum peak-to-peak waveform allowed for testing input timing.

Table 56. Measure and Test Condition Parameters

Symbol	PCI Level	Units	Notes
V_{th}	$0.6V_{CC}$	V	
V_{tl}	$0.2V_{CC}$	V	
V_{test}	$0.4V_{CC}$	V	
V_{step} (rising edge)	$0.285V_{CC}$	V	Min Delay
		V	Max Delay
V_{step} (falling edge)	$0.615V_{CC}$	V	Min Delay
		V	Max Delay
V_{max}	$0.4V_{CC}$	V	
Input Signal Edge Rate	1	V/ns	

10.4.2.2 PCI Timings

Table 57. PCI Timing Parameters

	Symbol	Parameter	Min	Max	Units	Notes
T14	t_{val}	PCI CLK to Signal Valid Delay	2	11	ns	1, 2, 3
T15	$t_{val(ptp)}$	PCI CLK to Signal Valid Delay (point-to-point)	2	12	ns	1, 2, 3
T16	t_{on}	Float to Active Delay	2		ns	1
T17	t_{off}	Active to Float Delay		28	ns	1
T18	t_{su}	Input Setup Time to CLK	7		ns	3, 4
T19	$t_{su(ptp)}$	PCI Input Setup Time to CLK (point-to-point)	10		ns	3, 4
T20	t_h	Input Hold Time from CLK	0		ns	5
T21	t_{rst}	Reset Active Time After Power Stable	1		ms	5
T22	$T_{rst-clk}$	PCI Reset Active Time After CLK Stable	100		clocks	5
T23	$T_{rst-off}$	Reset Active to Output Float Delay		40	ns	5, 6

NOTES:

1. Timing measurement conditions are illustrated in Figure 22.
2. PCI minimum times are specified with loads as detailed in the PCI Bus Specification, Revision 2.1, Section 4.2.3.2.
3. In a PCI environment, REQ# and GNT# are point-to-point signals and have different output valid delay times and input setup times than bussed signals. All other signals are bussed.
4. Timing measurement conditions are illustrated in Figure 23.
5. RST# is asserted and de-asserted asynchronously with respect to the CLK signal.
6. All PCI interface output drivers are floated when RST# is active.

10.4.2.3 Flash Interface Timings

The 82551ER is designed to support up to 150 ns of Flash access time. The V_{pp} signal in the Flash implementation should be connected permanently to 12 V. Thus, writing to the Flash is controlled only by the FLWE# pin.

Table 58 provides the timing parameters for the Flash interface signals. The timing parameters are illustrated in Figure 24 and Figure 25.

Table 58. Flash Timing Parameters

	Symbol	Parameter	Min	Max	Units	Notes
T35	t_{flrwc}	Flash Read/Write Cycle Time	150		ns	1, Flash t_{AVAV} = 150 ns
T36	t_{flacc}	FLA to Read FLD Setup Time	150		ns	1, Flash t_{AVQV} = 150 ns
T37	t_{flce}	FLCS# to Read FLD Setup Time	150		ns	1, Flash t_{ELQV} = 150 ns
T38	t_{flo}	FLOE# Active to Read FLD Setup Time	120		ns	1, Flash t_{GLQV} = 55 ns

Table 58. Flash Timing Parameters

T39	t_{fldf}	FLOE# Inactive to FLD Driven Delay Time	50		ns	1, Flash t_{GHQZ} = 35 ns
T40	t_{flas}	FLA Setup Time before FLWE#	5		ns	2, Flash t_{AVWL} = 0 ns
T41	t_{flah}	FLA Hold Time after FLWE#	200		ns	2, Flash t_{WLAX} = 60 ns
T42	t_{flcs}	FLCS# Hold Time before FLWE#	30		ns	2, Flash t_{ELWL} = 20 ns
T43	t_{flch}	FLCS# Hold Time after FLWE#	30		ns	2, Flash t_{WHEH} = 0 ns
T44	t_{flds}	FLD Setup Time	150		ns	2, Flash t_{DVWH} = 50 ns
T45	t_{fldh}	FLD Hold Time	10		ns	2, Flash t_{WHDX} = 10 ns
T46	t_{flwp}	Write Pulse Width	120		ns	2, Flash t_{WLWH} = 60 ns
T47	t_{flwph}	Write Pulse Width High	25		ns	2, Flash t_{WHWL} = 20 ns
T48	t_{Mioha}	IOCHRDY Hold Time after FLWE# or FLOE# Active		25	ns	
T49	t_{Miohi}	IOCHRDY Hold Time after FLWE# or FLOE# Inactive	0		ns	

NOTES:

1. These timing specifications apply to Flash read cycles. The Flash timings referenced are 28F020-150 timings.
2. These timing specifications apply to Flash write cycles. The Flash timings referenced are 28F020-150 timings.

Figure 24. Flash Timings for a Read Cycle

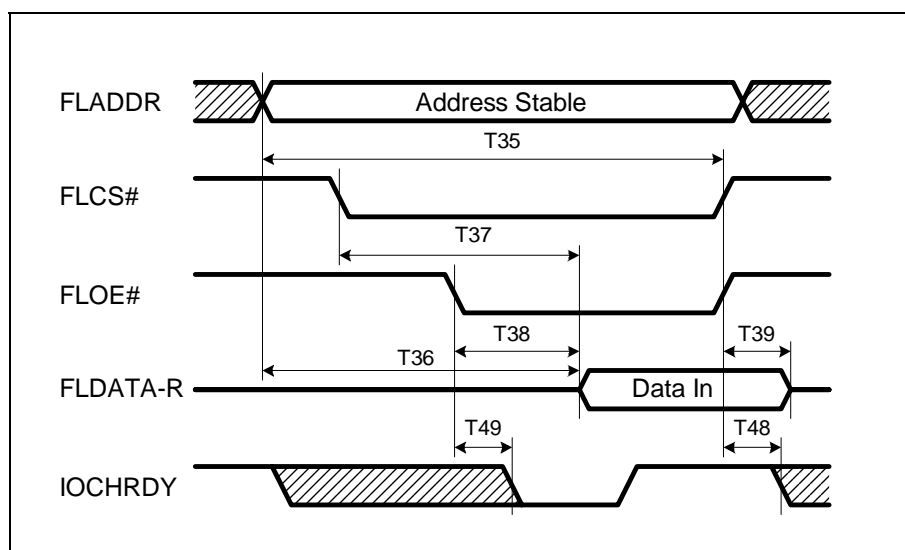
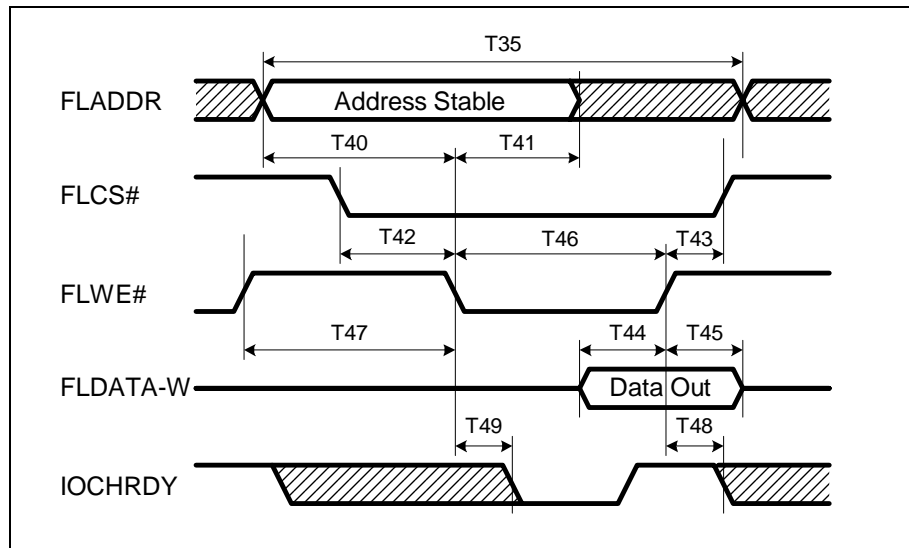

Figure 25. Flash Timings for a Write Cycle



10.4.2.4 EEPROM Interface Timings

The 82551ER is designed to support a standard 64x16 or 256x16 serial EEPROM. Table 59 provides the timing parameters for the EEPROM interface signals. The timing parameters are illustrated in Figure 26.

Table 59. EEPROM Timing Parameters

	Symbol	Parameter	Min	Max	Units	Notes
T51	t_{ECSS}	Delay from EECS High to EESK High	300		ns	EEPROM t_{css} = 50 ns
T52	t_{ECSH}	Delay from EESK Low to EECS Low	30		ns	EEPROM t_{csh} = 0 ns
T53	t_{EDIS}	Setup Time of EEDI to EESK	300		ns	EEPROM t_{dis} = 150 ns
T54	t_{EDIH}	Hold Time of EEDI after EESK	300		ns	EEPROM t_{dih} = 150 ns
T55	t_{ECS}	EECS Low Time	750		ns	EEPROM t_{cs} = 250 ns

Figure 26. EEPROM Timings

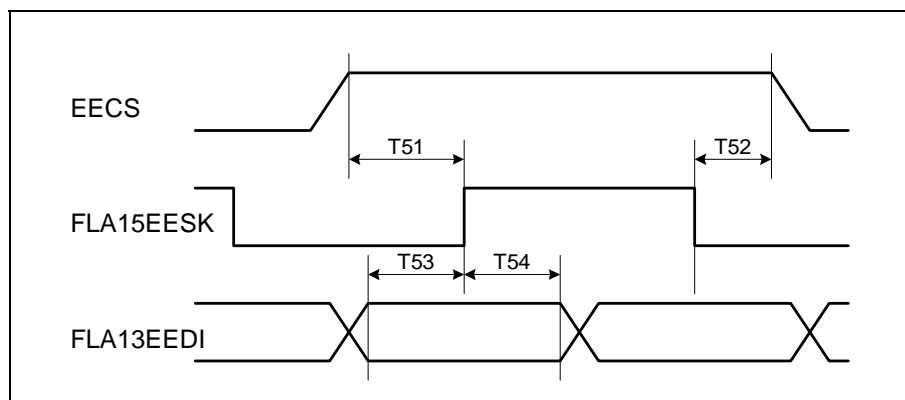

10.4.2.5 PHY Timings

Table 60. 10BASE-T Normal Link Pulse (NLP) Timing Parameters

	Symbol	Parameter	Condition	Min	Typ	Max	Units
T56	T_{nlp_wid}	NLP Width	10 Mbps		100		ns
T57	T_{nlp_per}	NLP Period	10 Mbps	8		24	ms

Figure 27. 10BASE-T Normal Link Pulse (NLP) Timings

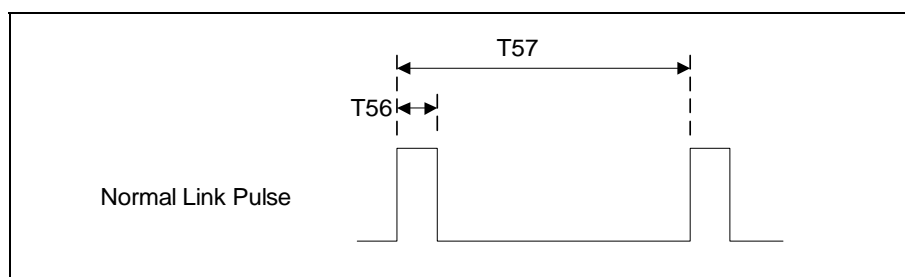

Table 61. Auto-Negotiation Fast Link Pulse (FLP) Timing Parameters

	Symbol	Parameter	Min	Typ	Max	Units
T58	T_{flp_wid}	FLP Width (clock/data)		100		ns
T59	$T_{flp_clk_clk}$	Clock Pulse to Clock Pulse Period	111	125	139	μ s
T60	$T_{flp_clk_dat}$	Clock Pulse to Data Pulse Period	55.5	62.5	69.5	μ s
T61	$T_{flp_bur_num}$	Number of Pulses in one burst	17		33	
T62	$T_{flp_bur_wid}$	FLP Burst Width		2		ms
T63	$T_{flp_bur_per}$	FLP Burst Period	8		24	ms

Figure 28. Auto-Negotiation Fast Link Pulse (FLP) Timings

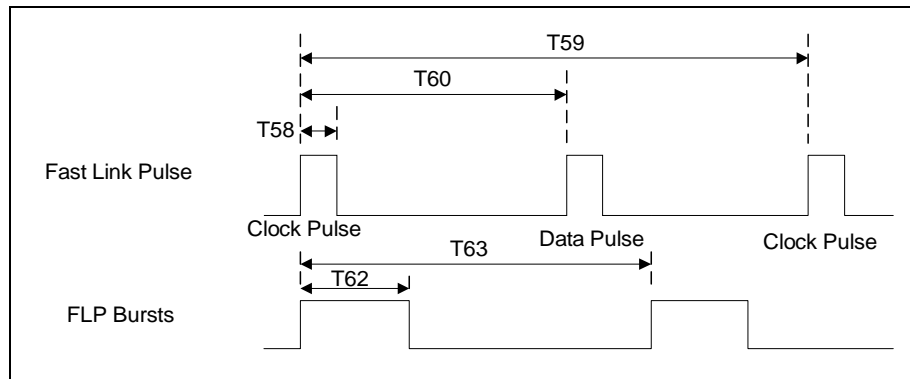

Table 62. 100Base-TX Transmitter AC Specification

	Symbol	Parameter	Condition	Min	Typ	Max	Units
T64	T_{jit}	TDP/TDN Differential Output Peak Jitter	HLS Data			1400	ps



11.0 Package and Pinout Information

11.1 Package Information

The 82551ER is a 196-pin Ball Grid Array (BGA) package. Package dimensions are shown in Figure 29. More information on Intel® device packaging is available in the Intel Packaging Handbook.

Figure 29. Dimension Diagram for the 196-pin BGA

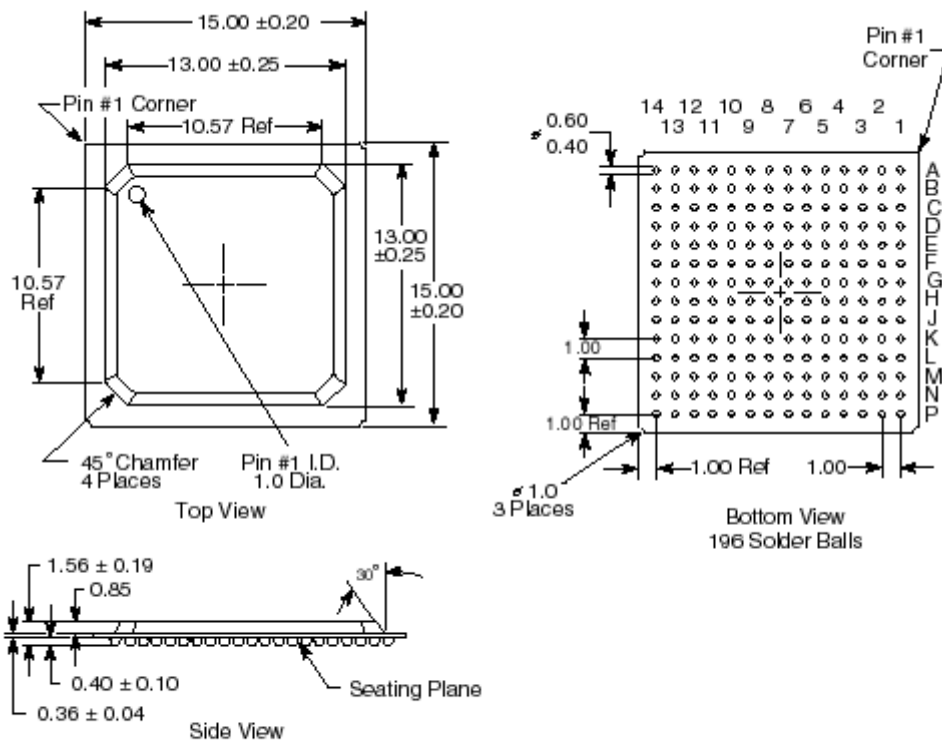

NOTE: All dimensions are in millimeters.

11.2 Pinout Information

11.2.1 Pin Assignments

Table 63. Pin Assignments

Pin	Name	Pin	Name	Pin	Name
A1	NC	A2	SERR#	A3	VCC
A4	IDSEL	A5	AD25	A6	PME#
A7	VCC	A8	AD30	A9	ALTRST#
A10	NC	A11	VCC	A12	LILED
A13	TEST	A14	NC		
B1	AD22	B2	AD23	B3	VSSPP
B4	AD24	B5	AD26	B6	AD27
B7	VSSPP	B8	AD31	B9	ISOLATE#
B10	NC	B11	SPEEDLED	B12	TO
B13	RBIAS100	B14	RBIAS10		
C1	AD21	C2	RST#	C3	REQ#
C4	C/BE3#	C5	NC	C6	AD28
C7	AD29	C8	CLKRUN#	C9	NC
C10	VSSPT	C11	ACTLED	C12	VREF
C13	TDP	C14	TDN		
D1	AD18	D2	AD19	D3	AD20
D4	VSS	D5	VSS	D6	VSS
D7	VSS	D8	VSS	D9	NC
D10	NC	D11	NC	D12	TI
D13	TEXEC	D14	TCK		
E1	VCC	E2	VSSPP	E3	AD17
E4	VSS	E5	VSS	E6	VSS
E7	VSS	E8	VSS	E9	VSS
E10	VSS	E11	NC	E12	VCC
E13	RDP	E14	RDN		
F1	IRDY#	F2	FRAME#	F3	C/BE2#
F4	VSS	F5	VSS	F6	VSS
F7	VSS	F8	VSS	F9	VSS
F10	VSS	F11	VSS	F12	FLD2
F13	FLD1	F14	FLD0		
G1	CLK	G2	VIO	G3	TRDY#
G4	NC	G5	VCC	G6	VCC
G7	VSS	G8	VSS	G9	VSS
G10	VSS	G11	VSS	G12	FLD3

Table 63. Pin Assignments

Pin	Name	Pin	Name	Pin	Name
G13	VCC	G14	VSSPL		
H1	STOP#	H2	INTA#	H3	DEVSEL#
H4	NC	H5	VCC	H6	VCC
H7	VCC	H8	VCC	H9	VSS
H10	VSS	H11	NC	H12	FLD6
H13	FLD5	H14	FLD4		
J1	PAR	J2	PERR#	J3	GNT#
J4	NC	J5	VCC	J6	VCC
J7	VCC	J8	VCC	J9	VCC
J10	VCCR	J11	VCCR	J12	FLA1
J13	FLA0	J14	FLD7		
K1	AD16	K2	VSSPP	K3	VCC
K4	VCC	K5	VCC	K6	VCC
K7	VCC	K8	VCC	K9	VCC
K10	VCC	K11	VCC	K12	VSSPL
K13	VCC	K14	FLA2		
L1	AD14	L2	AD15	L3	C/BE#1
L4	VCC	L5	VCC	L6	VSS
L7	NC	L8	NC	L9	VCC
L10	VCC	L11	VSS	L12	FLA5
L13	FLA4	L14	FLA3		
M1	AD11	M2	AD12	M3	AD13
M4	C/BE0#	M5	AD5	M6	VSSPP
M7	AD1	M8	FLOE#	M9	FLWE#
M10	FLA15/EESK	M11	FLA12	M12	FLA11
M13	FLA7	M14	FLA6		
N1	VSSPP	N2	AD10	N3	AD9
N4	AD7	N5	AD4	N6	VCC
N7	AD0	N8	VCC	N9	FLCS#
N10	FLA14/EEDO	N11	X1	N12	VSSPL
N13	FLA10	N14	FLA8		
P1	NC	P2	VCC	P3	AD8
P4	AD6	P5	AD3	P6	AD2
P7	EECS	P8	VSSPL	P9	FLA16
P10	FLA13/EEDI	P11	X2	P12	VCC
P13	FLA9	P14	NC		

