

VERTICAL DEFLECTION AND GUARD CIRCUIT (90°)

GENERAL DESCRIPTION

The TDA3653B/C is a vertical deflection output circuit for drive of various deflection systems with currents up to 1.5 A peak-to-peak.

Features

- Driver
- Output stage
- Thermal protection and output stage protection
- Flyback generator
- Voltage stabilizer
- Guard circuit

QUICK REFERENCE DATA

parameter	symbol	min.	typ.	max.	unit
Supply (note 1)					
Supply voltage range					
pin 9	$V_p = V_{9-4}$	10	—	40	V
pin 6	V_{6-4}	—	—	60	V
Output (pin 5)					
Peak output voltage during flyback	V_{5-4M}	—	—	60	V
Output current	$I_{5(p-p)}$	—	1.2	1.5	A
Operating junction temperature range	T_j	−25	—	+150	°C
Thermal resistance junction to mounting base					
(SOT110B)	$R_{th\ j-mb}$	—	10	—	K/W
(SOT131)	$R_{th\ j-mb}$	—	3.5	—	K/W

Note to the quick reference data

1. The maximum supply voltage should be chosen such that during flyback the voltage at pin 5 does not exceed 60 V.

PACKAGE OUTLINES

TDA3653B: 9-lead SIL; plastic (SOT110B).

TDA3653C: 9-lead SIL; plastic power (SOT131).

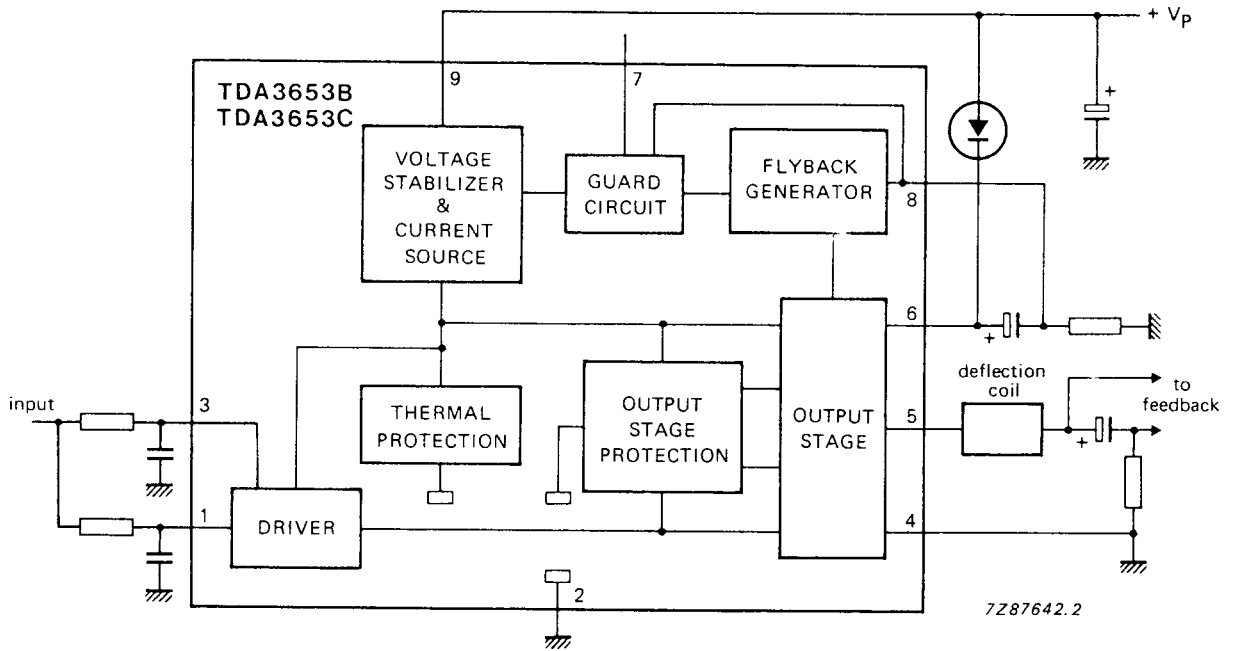

Fig. 1 Block diagram.

FUNCTIONAL DESCRIPTION

Output stage and protection circuit

Pin 5 is the output pin. The supply for the output stage is fed to pin 6 and the output stage ground is connected to pin 4. The output transistors of the class-B output stage can each deliver 0.75 A maximum. The maximum voltage for pin 5 and 6 is 60 V.

The output power transistors are protected such that their operation remains within the SOAR area. This is achieved by the co-operation of the thermal protection circuit, the current-voltage detector, the short-circuit protection and the special measures in the internal circuit layout.

Driver and switching circuit

Pin 1 is the input for the driver of the output stage. The signal at pin 1 is also applied via external resistors to pin 3 which is the input of a switching circuit. When the flyback starts, this switching circuit rapidly turns off the lower output stage and so limits the turn-off dissipation. It also allows a quick start of the flyback generator.

External connection of pin 1 to pin 3 allows for applications in which the pins are driven separately.

Flyback generator

During scan the capacitor connected between pins 6 and 8 is charged to a level which is dependent on the value of the resistor at pin 8 (see Fig.1).

When the flyback starts and the voltage at the output pin (pin 5) exceeds the supply voltage, the flyback generator is activated.

The supply voltage is then connected in series, via pin 8, with the voltage across the capacitor during the flyback period.

This implies that during scan the supply voltage can be reduced to the required scan voltage plus saturation voltage of the output transistors.

The amplitude of the flyback voltage can be chosen by changing the value of the external resistor at pin 8.

It should be noted that the application is chosen such that the lowest voltage at pin 8 is > 2.5 V, during normal operation.

Guard circuit

When there is no deflection current and the flyback generator is not activated, the voltage at pin 8 reduces to less than 1.8 V. The guard circuit will then produce a DC voltage at pin 7, which can be used to blank the picture tube and thus prevent screen damage.

Voltage stabilizer

The internal voltage stabilizer provides a stabilized supply of 6 V to drive the output stage, which prevents the drive current of the output stage being affected by supply voltage variations.

RATINGS

Limiting values in accordance with the Absolute Maximum System (IEC 134); pins 4 and 2 externally connected to ground.

parameter	symbol	min.	max.	unit
Supply voltage (pin 9)	$V_P = V_{9-4}$	--	40	V
Supply voltage output stage (pin 6)	V_{6-4}	—	60	V
Output voltage (pin 5)	V_{5-4}	—	60	V
Input voltage (pins 1 and 3)	$V_{1; 3-2}$	—	V_P	V
External voltage at pin 7	V_{7-2}	—	5.8	V
Peak output current (pin 5)				
repetitive	$\pm I_{5RM}$	—	0.75	A
non-repetitive	$\pm I_{5SM}$	—	1.5	A*
Peak output current (pin 8)				
repetitive	I_{8RM}	0.85	0.75	A
non-repetitive	$\pm I_{8SM}$	—	1.5	A*
Total power dissipation	P_{tot}	see Fig. 2		
Storage temperature range	T_{stg}	−55	+150	°C
Operating ambient temperature range	T_{amb}	see Fig. 2		
Operating junction temperature range	T_j	−25	+150	°C

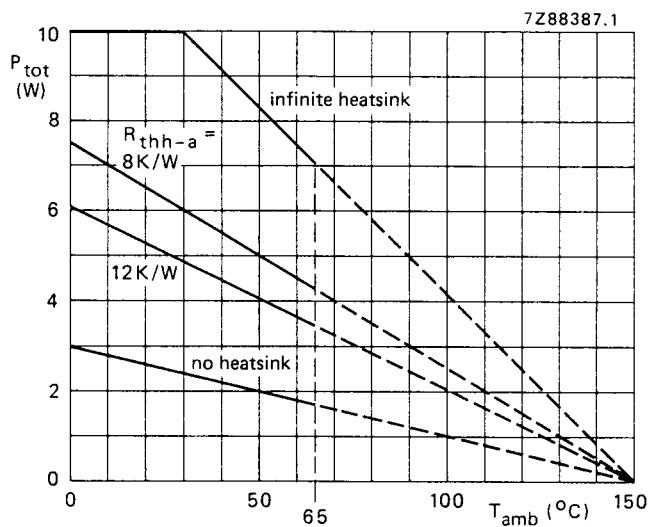

Fig. 2 Power derating curves (for SOT110B).

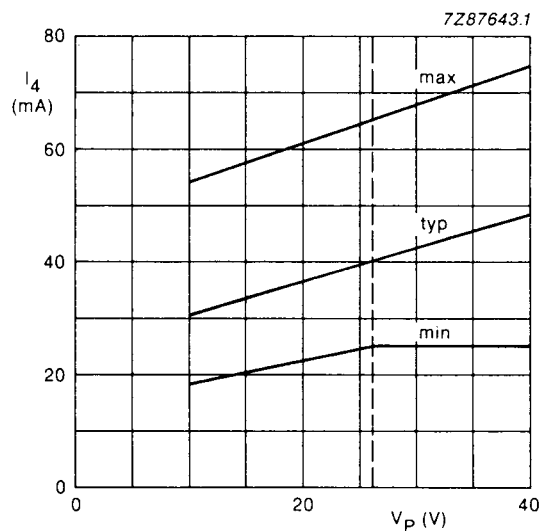

Fig. 3 Quiescent current I_4 as a function of supply voltage V_P .

* Non-repetitive duty factor maximum 3.3%.

CHARACTERISTICS

$V_p = V_{9-4} = 26 \text{ V}$; $T_{\text{amb}} = 25 \text{ }^\circ\text{C}$; pins 2 and 4 externally connected to ground; unless otherwise specified

parameter	conditions	symbol	min.	typ.	max.	unit
Supply						
Supply voltage (pin 9)	note 1	$V_p = V_{9-4}$	10	—	40	V
Supply voltage (pin 6)	note 1	V_{6-4}	—	—	60	V
Total supply current (pin 6 and pin 9)	note 2	$I_p = I_6 + I_9$	34	50	85	mA
Quiescent current (pin 4)	see Fig. 3	I_4	25	40	65	mA
Variation of quiescent current with temperature		ΔI_4	—	-0.04	—	mA/K
Output current						
Output current (pin 5) (peak-to-peak value)		$I_{5(p-p)}$	—	1.2	1.5	A
Output current flyback generator (pin 8)		$-I_8$	—	0.7	0.85	A
Output current flyback generator (pin 8)		I_8	—	0.6	0.75	A
Output voltage						
Peak voltage during flyback		V_{5-4M}	—	—	60	V
Saturation voltage to supply at $-I_5 = 0.75 \text{ A}$	note 3	V_{6-5sat}	—	2.5	3.0	V
at $I_5 = 0.75 \text{ A}$	note 3	V_{5-6sat}	—	2.5	3.0	V
at $-I_5 = 0.60 \text{ A}$	note 3	V_{6-5sat}	—	2.2	2.7	V
at $I_5 = 0.60 \text{ A}$	note 3	V_{5-6sat}	—	2.3	2.8	V
Saturation voltage to ground at $I_5 = 0.75 \text{ A}$		V_{5-4sat}	—	2.3	2.7	V
at $I_5 = 0.60 \text{ A}$		V_{5-4sat}	—	2.1	2.4	V
Flyback generator						
Saturation voltage at $-I_8 = 0.85 \text{ A}$	note 3	V_{9-8sat}	—	1.6	2.1	V
at $I_8 = 0.75 \text{ A}$	note 3	V_{8-9sat}	—	2.3	2.8	V
at $-I_8 = 0.70 \text{ A}$	note 3	V_{9-8sat}	—	1.4	1.9	V
at $I_8 = 0.60 \text{ A}$	note 3	V_{8-9sat}	—	2.2	2.7	V
Flyback generator active if:		V_{5-9}	4.0	—	—	V
Leakage current at pin 8		$-I_8$	—	5.0	100	μA
Input						
Input current (pin 1)	$I_5 = 0.75 \text{ A}$	I_1	—	0.33	0.55	mA
Input voltage during scan (pin 1)	$I_5 = 0.75 \text{ A}$	V_{1-2}	—	1.5	2.4	V
Input voltage during scan (pin 3) pins 1 and 3 not connected		V_{3-2}	0.8	—	V_p	V

CHARACTERISTICS (continued)

parameter	conditions	symbol	min.	typ.	max.	unit
Input (continued)						
Input current during scan (pin 3) pins 1 and 3 not connected		I_3	0.03	—	—	mA
pins 1 and 3 connected		I_3	—	—	0.21	mA
Input resistance (pin 3)		R_3	3.9	5.3	6.7	k Ω
Input voltage during flyback (pin 1)		V_{1-2}	—	—	250	mV
Input voltage during flyback (pin 3)		V_{3-2}	—	—	250	mV
Guard circuit						
Output voltage (pin 7) loaded with 100 k Ω loaded with 0.5 mA	note 4	V_{7-2}	4.4	5.1	5.8	V
		V_{7-2}	3.6	4.4	5.3	V
Internal series resistance of pin 7		R_{i7}	0.95	1.35	1.7	k Ω
Guard circuit active if V_{8-2} is lower than	note 5	V_{8-2}	—	—	1.8	V
General data						
Thermal protection becomes active if junction temperature exceeds		T_j	158	175	192	$^{\circ}\text{C}$
Thermal resistance junction to mounting base		$R_{th\ j-mb}$	—	10	12	K/W
Open loop gain at 1 kHz	note 6	G_{ol}	—	42	—	dB
Frequency response (–3 dB)	note 7	f	—	40	—	kHz

Notes to the characteristics

1. The maximum supply voltage should be chosen such that during flyback the voltage at pin 5 does not exceed 60 V.
2. When $V_{5-4} = 13$ V and no load at pin 5.
3. Duty factor maximum 3.3%.
4. Guard circuit is active.
5. During normal operation the voltage V_{8-2} may not be lower than 2.5 V.
6. $R_{load} = 8\ \Omega$; $I_{load(rms)} = 125$ mA.
7. With 220 pF between pins 1 and 5.

APPLICATION INFORMATION

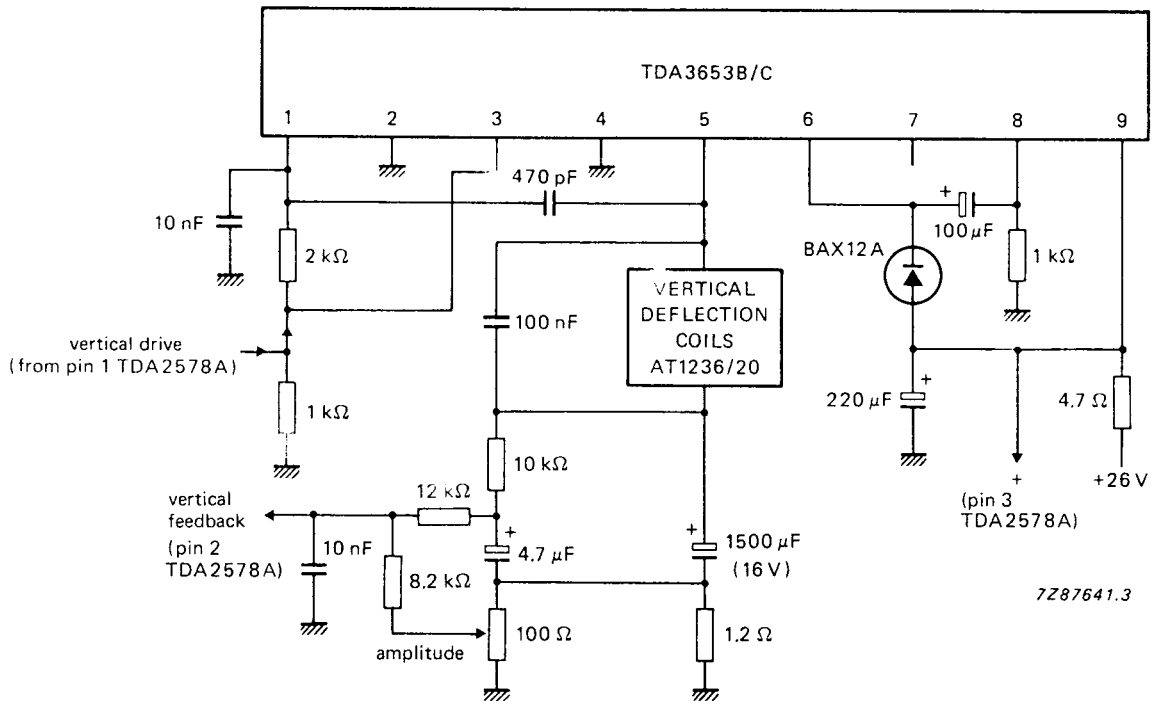

Fig. 4 Typical application circuit diagram of the TDA3653B/C (vertical output), when used in combination with the TDA2578A (see Fig. 5).

Note to deflection coils AT1236/20: $L = 29 \text{ mH}$, $R = 13.6 \Omega$; deflection current without overscan is 0.82 A peak-to-peak and EHT voltage is 25 kV.

APPLICATION INFORMATION (continued)

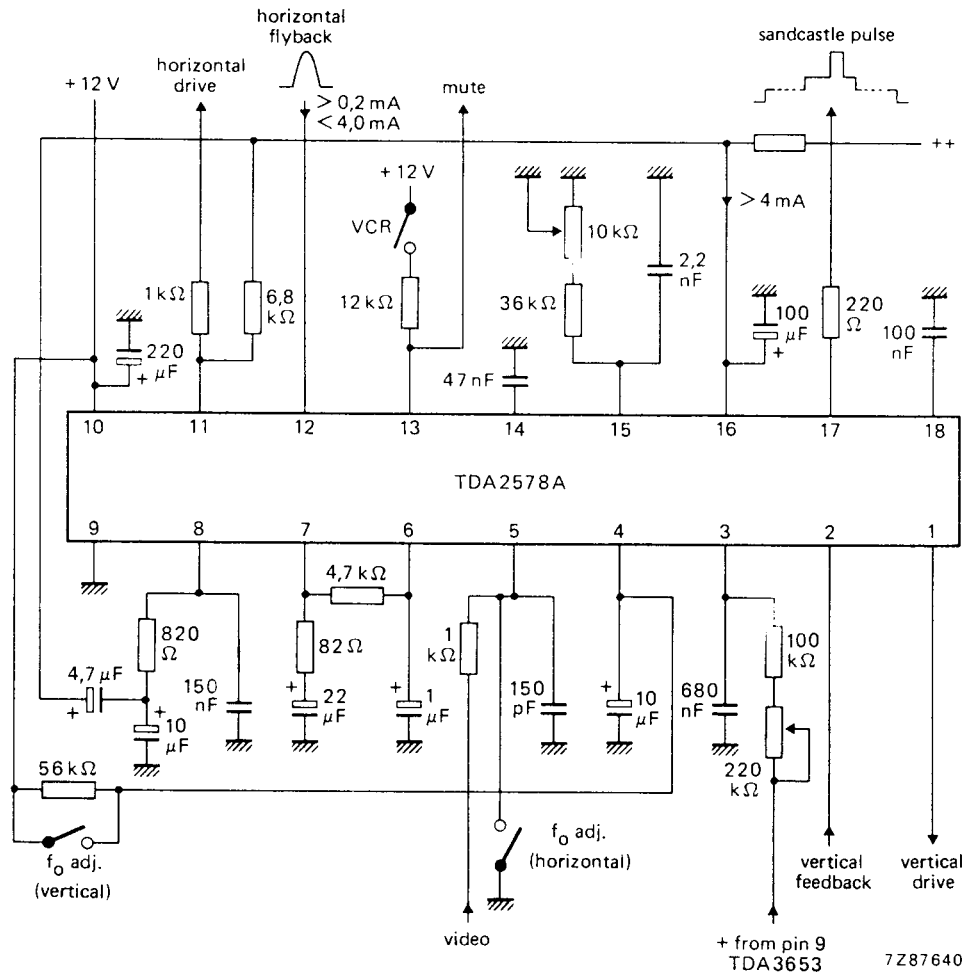
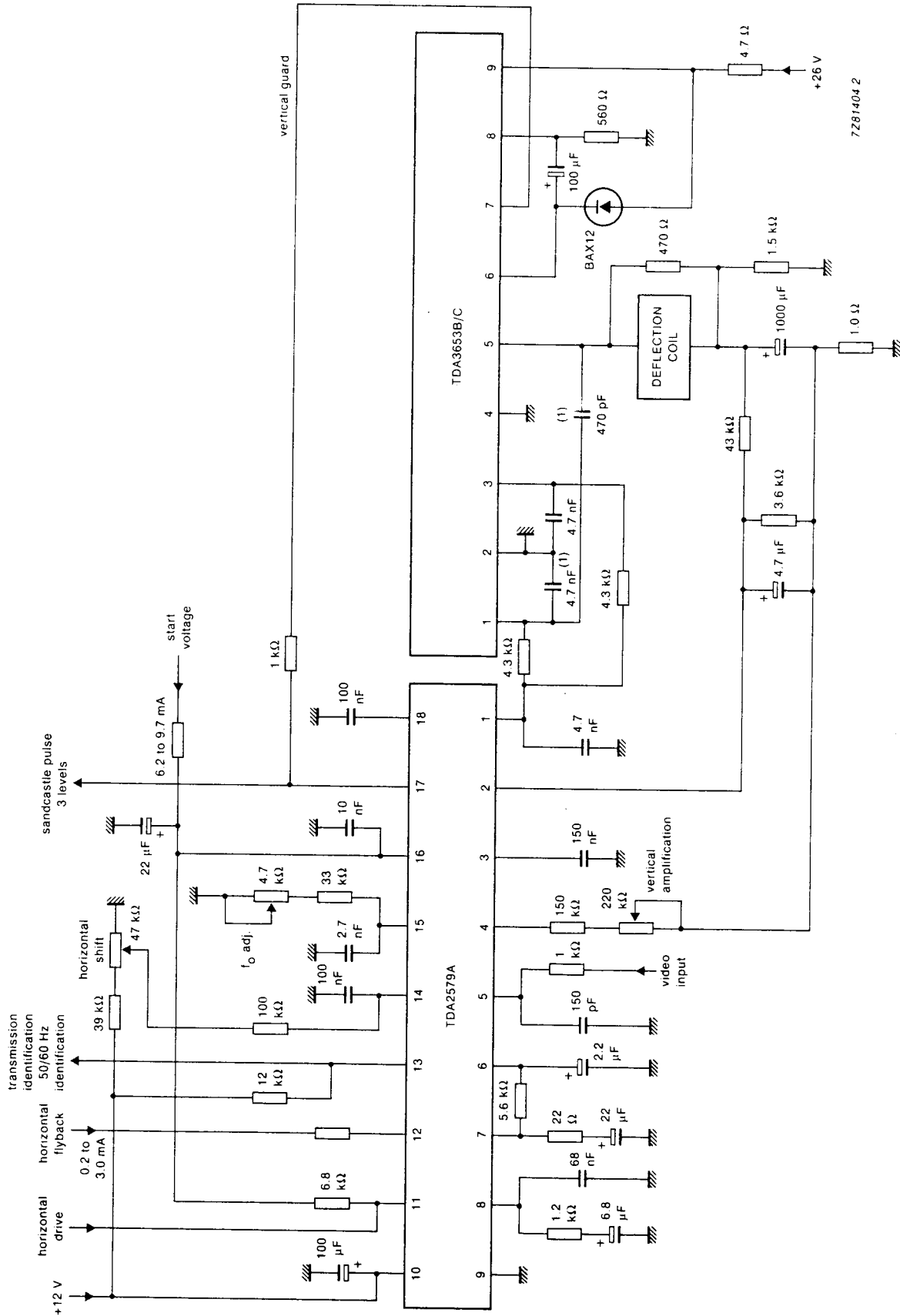

Fig. 5 Typical application circuit diagram; for combination of the TDA2578A with the TDA3653B/C (see Fig. 4).



7Z81404 2

(1) Dependent on PCB layout.

Fig.6 Application circuit diagram for combination with TDA2579A for 90° picture tube.