

Low On-Resistance Wideband/Video Quad 2-Channel Mux/DeMux

Features

- High-performance solution to switch between video sources
- Wide bandwidth: 200 MHz
- Low On-Resistance: 3Ω
- Low crosstalk at 10 MHz: -58dB
- Ultra-low quiescent power (0.1μA typical)
- Single supply operation: +5.0V
- Fast switching: 10ns
- High-current output: 100mA
- Packaging (Pb-free & Green Available):
 - 16-pin 300-mil wide plastic SOIC (S)
 - 16-pin 150-mil wide plastic SOIC (W)
 - 16-pin 150-mil wide plastic QSOP (Q)

Description

Pericom Semiconductor's PI5V330 is a true bidirectional Quad 2-channel multiplexer/demultiplexer recommended for both RGB and composite video switching applications. The video switch can be driven from a current output RAMDAC or voltage output composite video source.

Low On-Resistance and wide bandwidth make it ideal for video and other applications. Also this device has exceptionally high current capability which is far greater than most analog switches offered today. A single 5V supply is all that is required for operation.

The PI5V330 offers a high-performance, low-cost solution to switch between video sources. The application section describes the PI5V330 replacing the HC4053 multiplier and buffer/amplifier.

Block Diagram

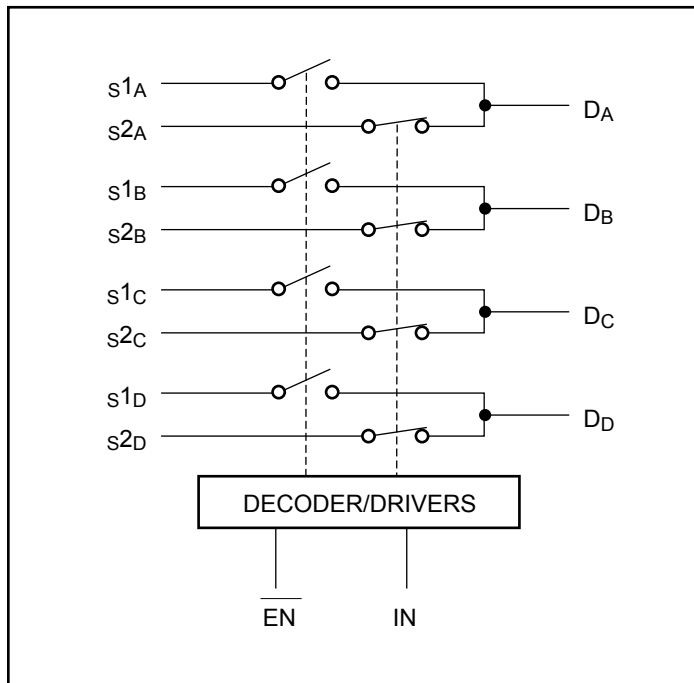

Truth Table

| EN | IN | ON Switch |
|----|----|--------------------|
| 0 | 0 | s1A, s1B, s1C, s1D |
| 0 | 1 | s2A, s2B, s2C, s2D |
| 1 | X | Disabled |

Pin Configuration

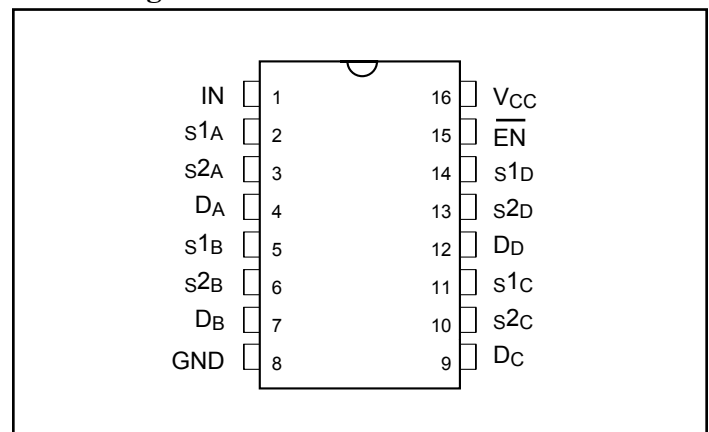

Pin Description

| Pin Name | Description |
|--|------------------|
| s1A, s1B, s1C, s1D s2A, s2B, s2C, s2D | Analog Video I/O |
| IN | Select Input |
| EN | Enable |
| DA, DB DC, DD | Analog Video I/O |
| GND | Ground |
| VCC | Power |

Maximum Ratings

(Above which the useful life may be impaired. For user guidelines, not tested.)

| | |
|---|-----------------|
| Storage Temperature | -65°C to +150°C |
| Ambient Temperature with Power Applied | -40°C to +85°C |
| Supply Voltage to Ground Potential (Inputs & V _{CC} Only)... | -0.5V to +7.0V |
| Supply Voltage to Ground Potential (Outputs & D/O Only) | -0.5V to +7.0V |
| DC Input Voltage | -0.5V to +7.0V |
| DC Output Current..... | 120mA |
| Power Dissipation | 0.5W |

Note:

Stresses greater than those listed under MAXIMUM RATINGS may cause permanent damage to the device. This is a stress rating only and functional operation of the device at these or any other conditions above those indicated in the operational sections of this specification is not implied. Exposure to absolute maximum rating conditions for extended periods may affect reliability.

DC Electrical Characteristics (Over the Operating Range, T_A = -40°C to +85°C, V_{CC} = 5V ±5%)

| Parameters | Description | Test Conditions ⁽¹⁾ | Min. | Typ. ⁽²⁾ | Max. | Units |
|---------------------|--------------------------------------|---|------|---------------------|------|-------|
| V _{ANALOG} | Analog Signal Range | | 0 | - | 2.0 | V |
| V _{IH} | Input HIGH Voltage | Guaranteed Logic HIGH Level | 2.0 | - | - | |
| V _{IL} | Input LOW Voltage | Guaranteed Logic LOW Level | -0.5 | - | 0.8 | |
| I _{IH} | Input HIGH Current | V _{CC} = Max., V _{IN} = V _{CC} | - | - | ±1 | µA |
| I _{IL} | Input LOW Current | V _{CC} = Max., V _{IN} = GND | - | - | ±1 | |
| I _O | Analog Output Leakage Current | 0 ≤ S1, S2 or D ≤ V _{CC} , Switch OFF | - | - | ±1 | |
| V _{IK} | Clamp Diode Voltage | V _{CC} = Min., I _{IN} = -18mA | -0.7 | -1.2 | | V |
| I _{OS} | Short Circuit Current ⁽³⁾ | S1, S2, D = 0V V _{CC} | 100 | - | - | mA |
| V _H | Input Hysteresis at Control Pins | | - | 150 | - | mV |
| R _{ON} | Switch On-Resistance ⁽⁴⁾ | V _{CC} = Min., V _{IN} = 1.0V, R _L = 75Ω, I _{ON} = 13mA | - | 3 | 7 | Ω |
| | | V _{CC} = Min., V _{IN} = 2.0V, R _L = 75Ω, I _{ON} = 26mA | - | 7 | 10 | |

Notes:

1. For Max. or Min. conditions, use appropriate value specified under Electrical Characteristics for the applicable device type.
2. Typical values are at V_{CC} = 5.0V, T_A = 25°C ambient and maximum loading.
3. Not more than one output should be shorted at one time. Duration of the test should not exceed one second.
4. Measured by the voltage drop between S1, S2, and D I/O pins at indicated current through the switch. On-Resistance is determined by the lower of the voltages on the S1, S2, and D I/O pins.

Dynamic Characteristics (Over the Operating Range, $T_A = -40^{\circ}\text{C}$ to $+85^{\circ}\text{C}$, $V_{CC} = 5\text{V} \pm 5\%$)

| Parameters | Description | Test Conditions | Min. | Typ. | Max. | Unit |
|-----------------|--------------------------|---|------|------|------|------|
| t_{ON} | Turn On Time | $R_L = 75\Omega$, $C_L = 20\text{pF}$, See Fig. 6 | - | 2.5 | 5 | ns |
| t_{OFF} | Turn Off Time | $R_L = 75\Omega$, $C_L = 20\text{pF}$, See Fig. 6 | - | 1.1 | 5 | |
| $BW^{(1)}$ | -3 dB Bandwidth | $R_L = 150\Omega$, See Fig. 7 | 180 | 400 | - | MHz |
| X_{TALK} | Crosstalk | $R_{IN} = 10\Omega$; $R_L = 150\Omega$, 10MHz, See Fig. 7 | - | -58 | - | dB |
| D_G | Differential Gain | $R_L = 150\Omega$, $f = 3.58\text{ MHz}$, See Fig. 5 | - | 0.64 | - | % |
| D_p | Differential Phase | $R_L = 150\Omega$, $f = 3.58\text{ MHz}$, See Fig. 5 | - | 0.27 | - | Deg. |
| $C_{IN}^{(1)}$ | Input/Enable Capacitance | $V_{IN} = 0\text{V}$, $f = 1\text{ MHz}$ | - | - | 6 | pF |
| $C_{OFF}^{(1)}$ | Capacitance, Switch Off | $V_{IN} = 0\text{V}$, $f = 1\text{ MHz}$ | - | - | 6 | |
| $C_{ON}^{(1)}$ | Capacitance, Switch On | $V_{IN} = 0\text{V}$, $f = 1\text{ MHz}$ | - | - | 8 | |
| O_{IRR} | Off Isolation | $R_L = 150\Omega$, 10MHz, See Fig 7 | - | -38 | - | dB |

Notes:

1. This parameter is determined by device characterization but is not production tested.

Power Supply Characteristics

| Parameters | Description | Test Conditions ⁽¹⁾ | | Min. | Typ ⁽²⁾ | Max. | Units |
|-----------------|---|---|------------------------------|------|--------------------|------|---------------|
| I_{CC} | Quiescent Power Supply Current | $V_{CC} = \text{Max.}$ | $IN = \text{GND or } V_{CC}$ | - | 0.1 | 3.0 | μA |
| ΔI_{CC} | Supply Current per Input @ TTL HIGH | $V_{CC} = \text{Max.}$ | $IN = 3.4\text{V}^{(3)}$ | - | - | 2.5 | mA |
| I_{CCD} | Supply Current per Input per MHz ⁽⁴⁾ | $V_{CC} = \text{Max.}$, S1, S2 and D Pins Open $\overline{EN} = \text{GND}$ Control Input Toggling 50%Duty Cycle | | - | | 0.25 | mA/ MHz |

Notes:

1. For Max. or Min. conditions, use appropriate value specified under Electrical Characteristics for the applicable device.
2. Typical values are at $V_{CC} = 5.0\text{V}$, $+25^{\circ}\text{C}$ ambient.
3. Per TTL driven input ($V_{IN} = 3.4\text{V}$, control inputs only); S1, S2, and D pins do not contribute to I_{CC} .
4. This current applies to the control inputs only and represent the current required to switch internal capacitance at the specified frequency. The S1, S2, and D I/O pins generate no significant AC or DC currents as they transition. This parameter is not tested, but is guaranteed by design.

Definitions

| Symbol | Description |
|-----------------------|---|
| R_{ON} | Resistance between source and drain with switch in the ON state. |
| I_O | Output leakage current measured at S1, S2, and D with the switch OFF. |
| V_{IN} | Digital voltage at the IN pin that selects between S1 and S2 analog inputs. |
| V_{EN} | A voltage that ENABLES the chip. |
| C_{IN} | Capacitance at the digital inputs. |
| C_{OFF} | Capacitance at analog I/O (S1, S2, D) with switch OFF. |
| C_{ON} | Capacitance at analog I/O (S1, S2, D) with switch ON. |
| V_{IH} | Minimum input voltage for logic HIGH. |
| V_{IL} | Minimum input voltage for logic LOW. |
| I_{IH} (I_{IL}) | Input current of the digital input. |
| I_{OS} | Minimum short circuit current for S1, S2 and D. |
| t_{ON} | Propagation delay measured between 50% of the digital input to 90% of the analog output when switch is turned ON. The peak analog voltage is 0.714V. |
| t_{OFF} | Propagation delay measured between 50% of the digital input to 90% of the analog output when switch is turned OFF. The peak analog voltage is 0.714V. |
| BW | Frequency response of the switch in the ON state measured at 3dB down. |
| X_{TALK} | Is an unwanted signal coupled from channel to channel. Measured in -dB. $X_{TALK} = 20 \text{ LOG } V_{OUT}/V_{IN}$. This is non-adjacent crosstalk. |
| D_G | Differential gain is the difference measurement between two bias levels, for instance analog input signals of 0V to 0.714V. |
| DP | Differential phase is the difference measurement between two bias levels, for instance analog input signals of 0V to 0.714V. |
| O_{IRR} | Off isolation is the resistance (measured in -dB) between the input and output with the switch off (NO). |

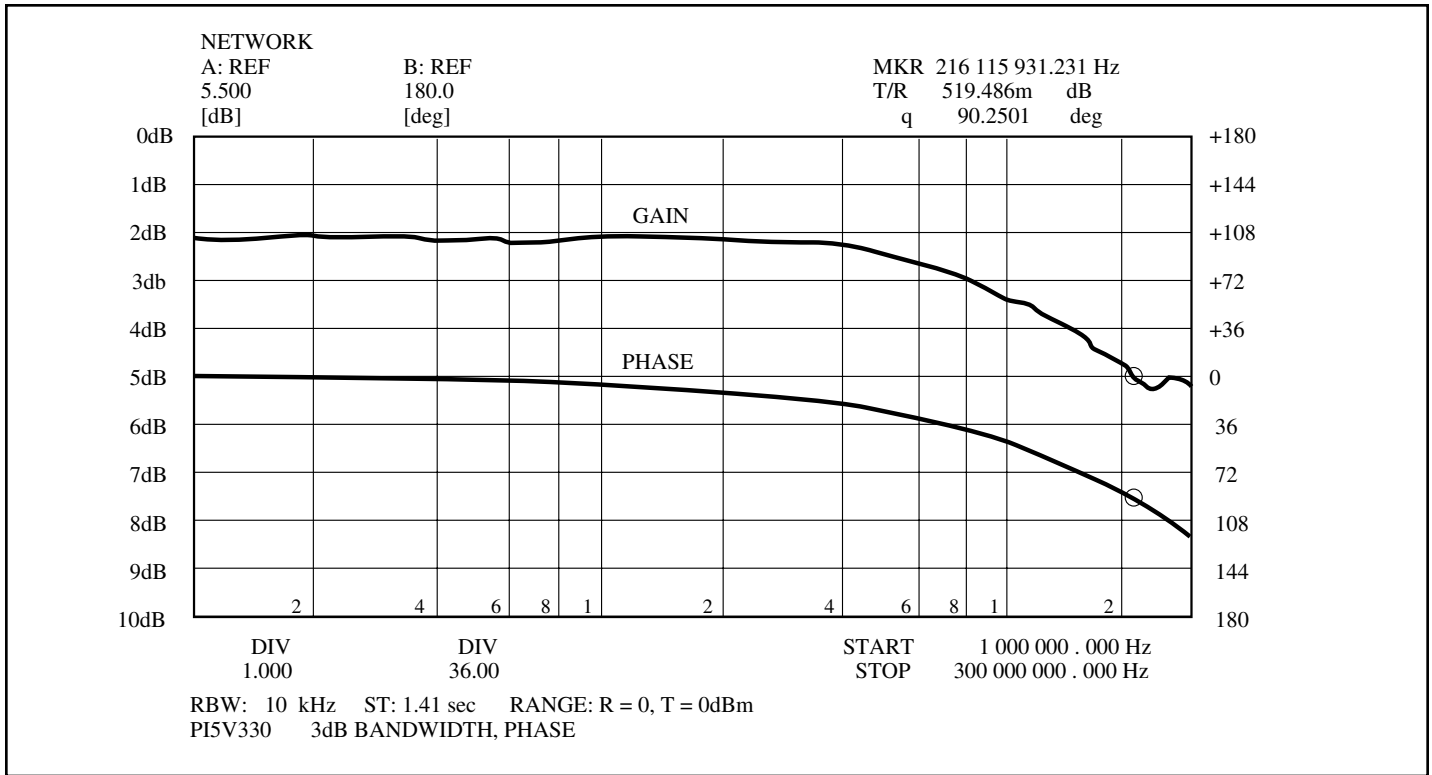

Figure 1. Gain/Phase vs Frequency

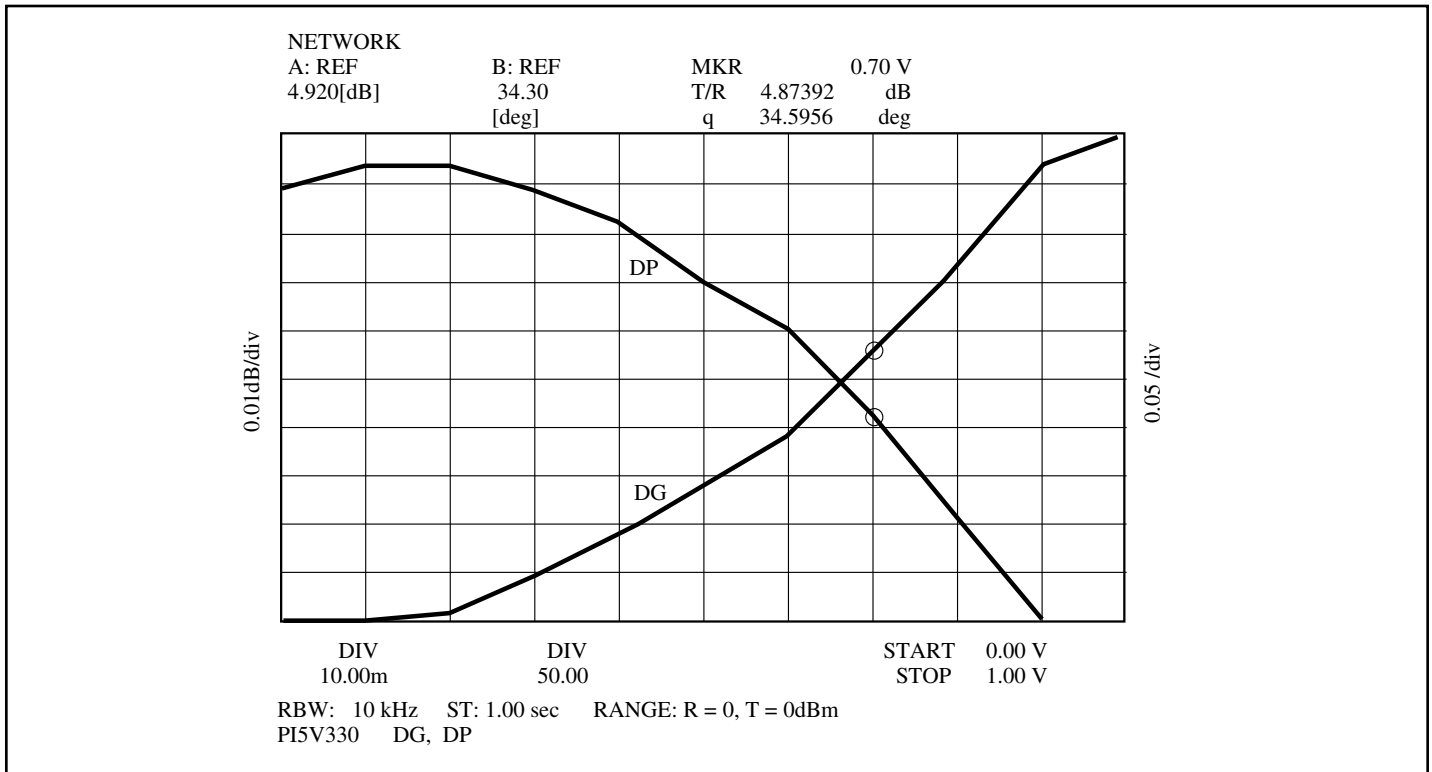

Figure 2. Differential Phase/Gain vs VBIAS

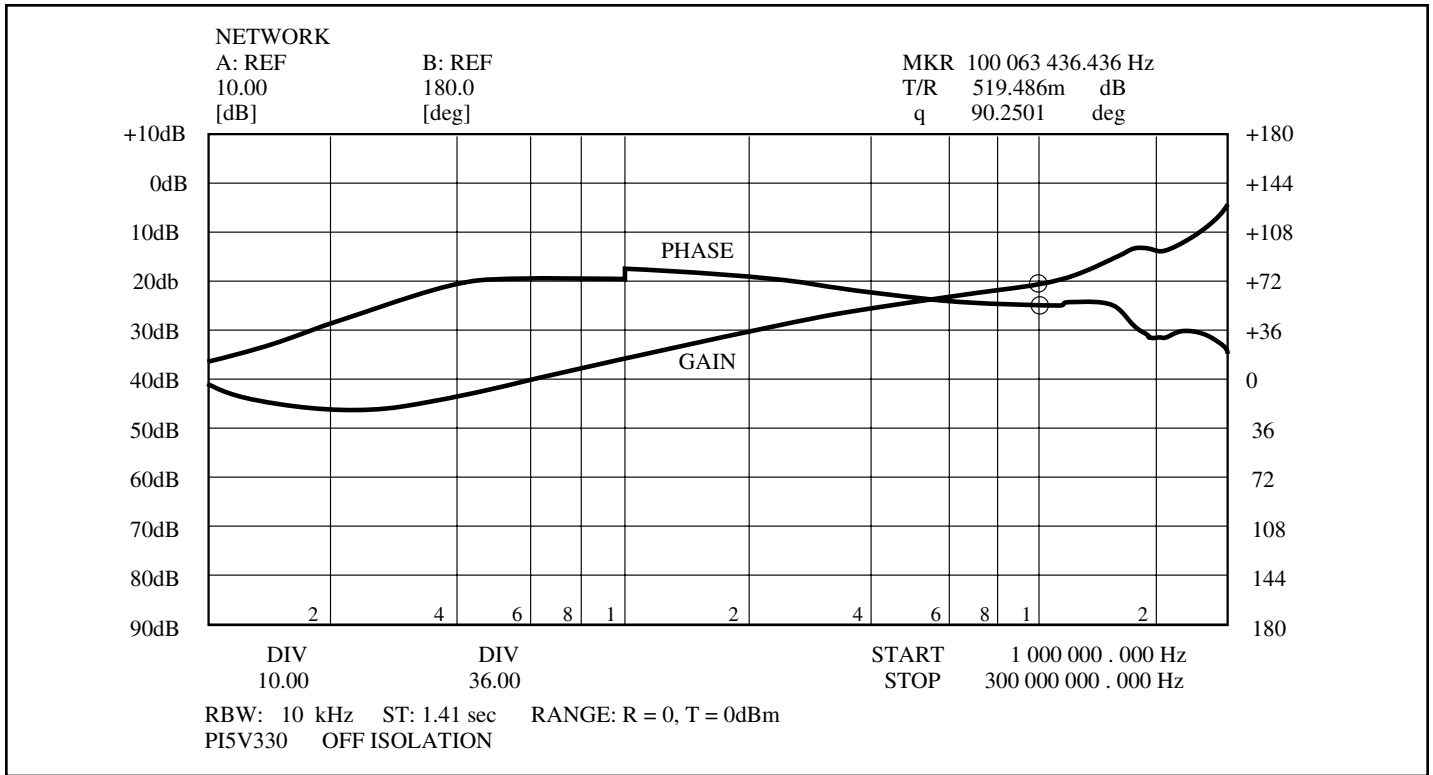

Figure 3. Off Isolation vs Frequency

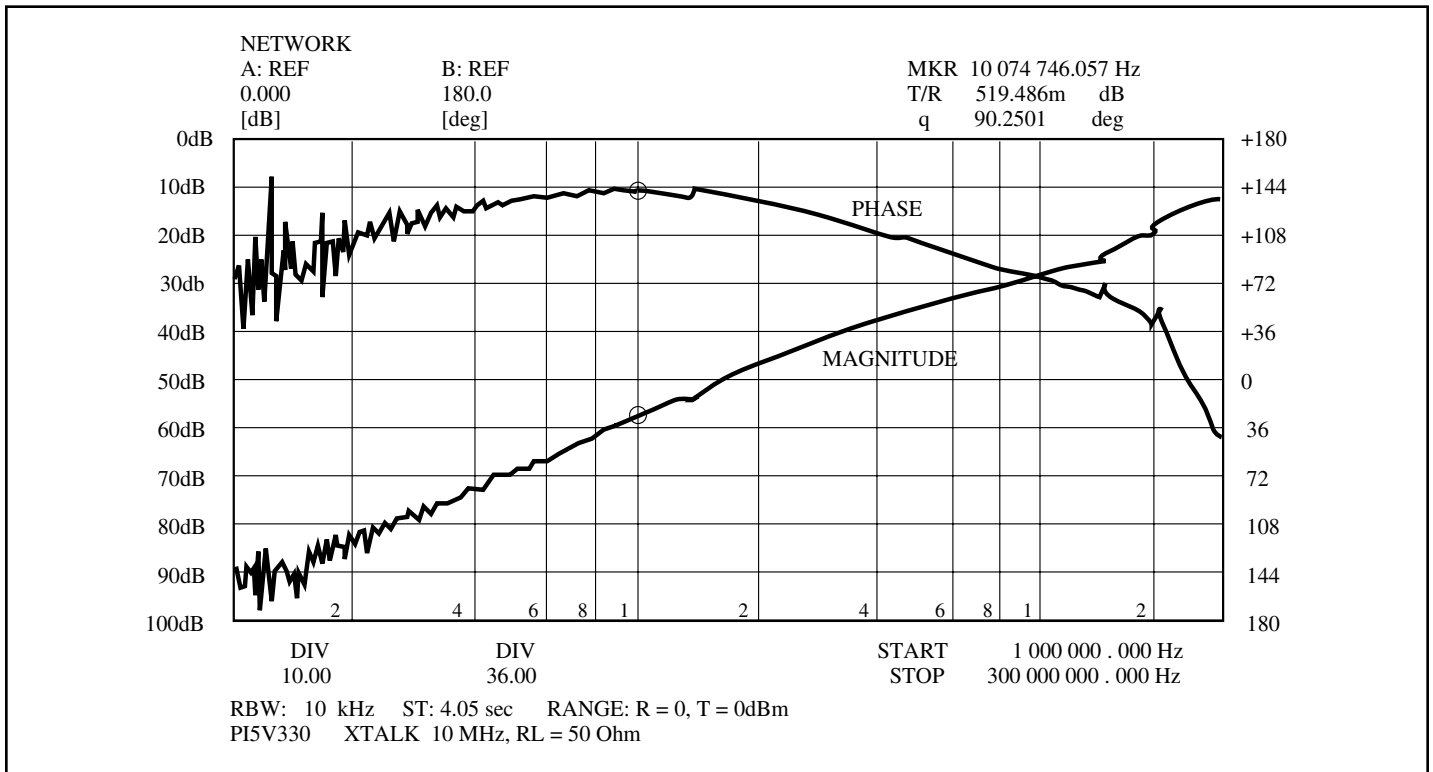

Figure 4. Crosstalk vs Frequency

Test Circuits

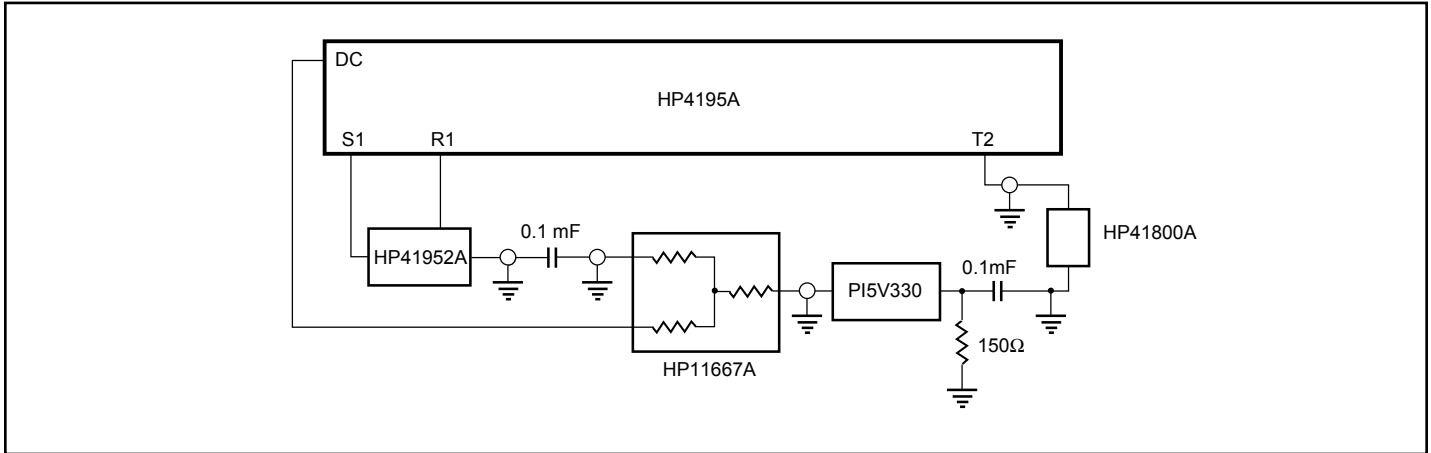

Figure 5. Differential Gain/Phase

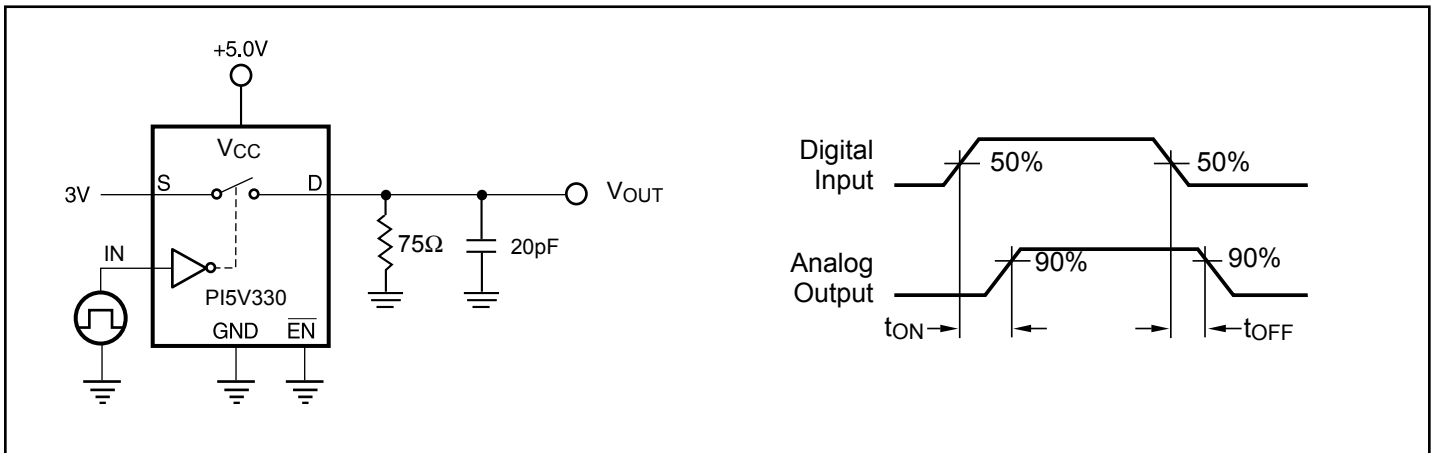

Figure 6. Switching Time

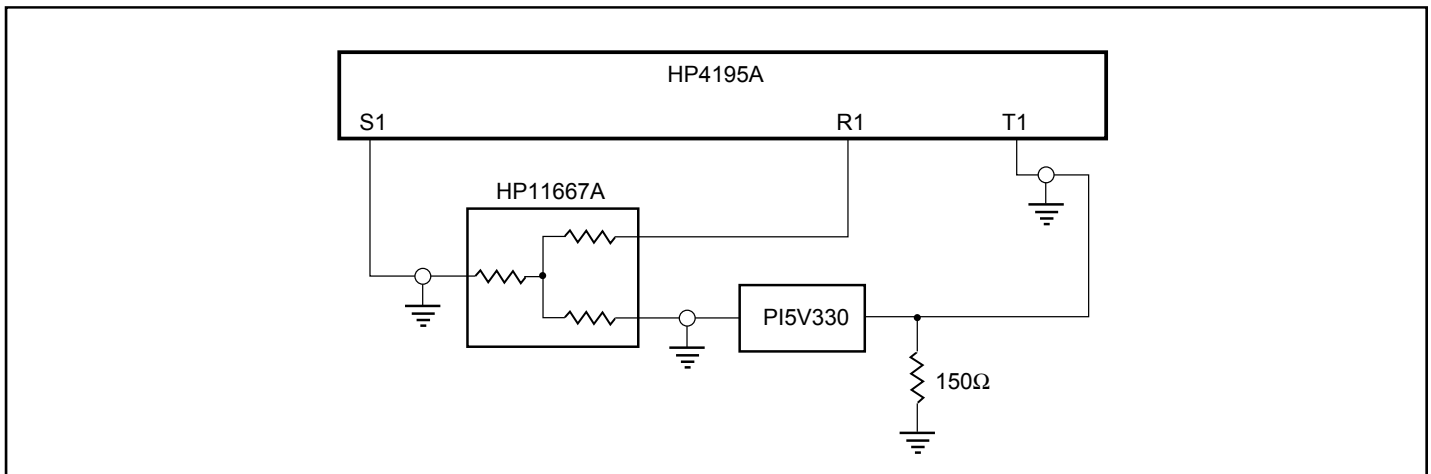
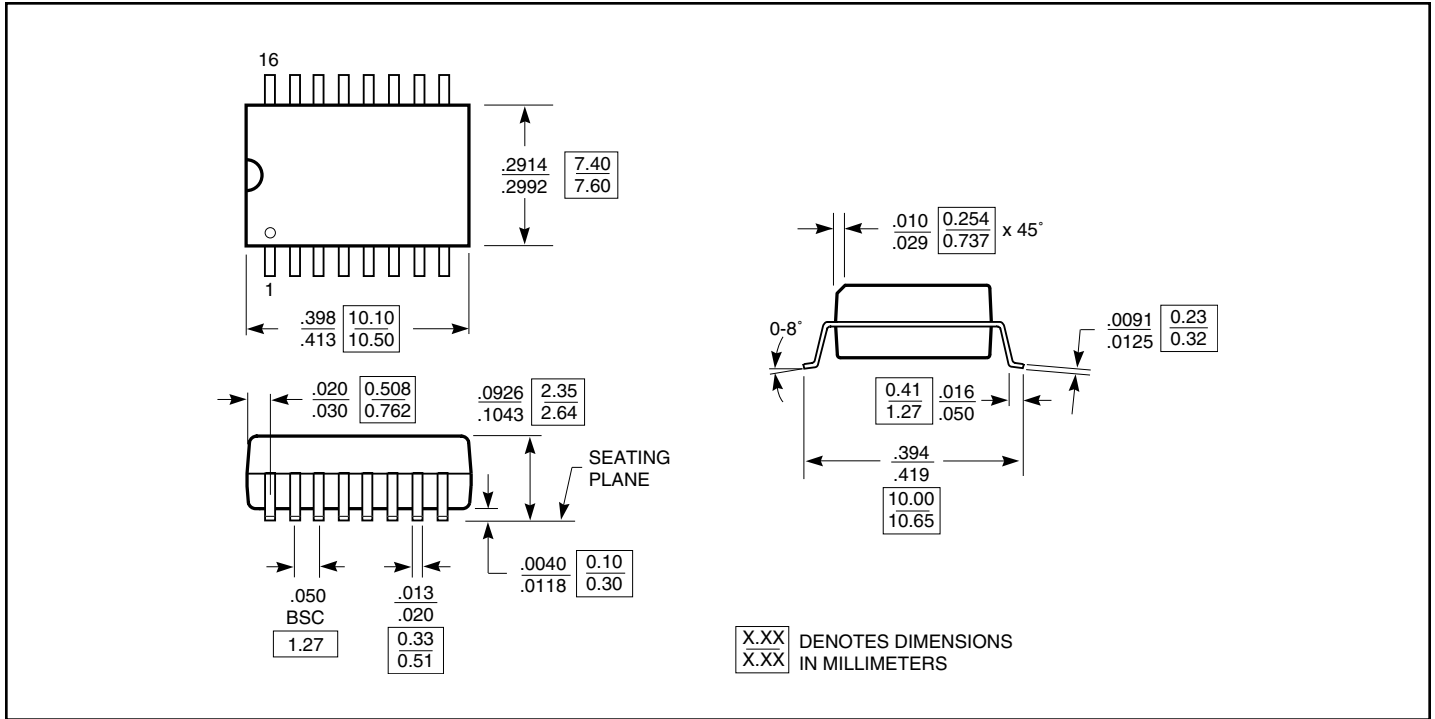

Figure 7. Gain/Phase, Crosstalk, Off-Isolation

Packaging Mechanical: 16-pin SOIC (S)



Packaging Mechanical: 16-pin SOIC (tW)

