

# DAC 3550A Stereo Audio DAC

Edition July 23, 1999  
6251-467-1DS

 MICRONAS

## Contents

Page	Section	Title
<b>3</b>	<b>1.</b>	<b>Introduction</b>
3	1.1.	Main Features
<b>5</b>	<b>2.</b>	<b>Functional Description</b>
5	2.1.	I <sup>2</sup> S Interface
6	2.2.	Interpolation Filter
6	2.3.	Variable Sample and Hold
6	2.4.	3rd-order Noise Shaper and Multibit DAC
6	2.5.	Analog Low-pass
6	2.6.	Input Select and Mixing Matrix
6	2.7.	Postfilter Op Amps, Deemphasis Op Amps, and Line-Out
7	2.8.	Analog Volume
7	2.9.	Headphone Amplifier
8	2.10.	Clock System
8	2.10.1.	Standard Mode
8	2.10.2.	MPEG Mode
9	2.11.	I <sup>2</sup> C Bus Interface
9	2.12.	Registers
9	2.13.	Chip Select
9	2.14.	Reduced Feature Mode
<b>10</b>	<b>3.</b>	<b>Specifications</b>
10	3.1.	Outline Dimensions
10	3.2.	Pin Connections and Short Descriptions
12	3.3.	Pin Descriptions
12	3.3.1.	Power Supply Pins
12	3.3.2.	Analog Audio Pins
12	3.3.3.	Oscillator and Clock Pins
13	3.3.4.	Other Pins
13	3.4.	Pin Configuration
14	3.5.	Pin Circuits
15	3.6.	Control Registers
17	3.7.	Electrical Characteristics
17	3.7.1.	Absolute Maximum Ratings
18	3.7.2.	Recommended Operating Conditions
20	3.7.3.	Characteristics
<b>25</b>	<b>4.</b>	<b>Applications</b>
25	4.1.	Line Output Details
25	4.2.	Recommended Low-Pass Filters for Analog Outputs
26	4.3.	Recommendations for Filters and Deemphasis
26	4.4.	Recommendations for MegaBass Filter without Deemphasis plus 1st-order low-pass
27	4.5.	Power-up/down Sequence
27	4.5.1.	Power-up Sequence
27	4.5.2.	Power-down Sequence
28	4.6.	Typical Applications
<b>32</b>	<b>5.</b>	<b>Data Sheet History</b>

## Stereo Audio DAC

### 1. Introduction

The DAC 3550A is a single-chip, high-precision, dual digital-to-analog converter designed for audio applications. The employed conversion technique is based on oversampling with noise-shaping.

With Micronas' unique multibit sigma-delta technique, less sensitivity to clock jitter, high linearity, and a superior S/N ratio has been achieved. The DAC 3550A is controlled via I<sup>2</sup>C bus.

Digital audio input data is received by a versatile I<sup>2</sup>S interface. The analog back-end consists of internal analog filters and op amps for cost-effective additional external sound processing. The DAC 3550A provides line-out, headphone/speaker amplifiers, and volume control. Moreover, mixing additional analog audio sources to the D/A-converted signal is supported.

The DAC 3550A is designed for all kinds of applications in the audio and multimedia field, such as: MPEG players, CD players, DVD players, CD-ROM players, etc. The DAC 3550A ideally complements the MPEG 1/2 layer 2/3 audio decoder MAS 3507D.

**No crystal required for standard applications with sample rates from 32 to 48 kHz.** Crystal required only for automatic sample rate detection below 32 kHz, MPEG mode (refer to Section 2.10), and use of clock output CLKOUT.

### 1.1. Main Features

- no master main input clock required
- integrated stereo headphone amplifier and mono speaker amplifier
- SNR of 103 dBA
- I<sup>2</sup>C bus, I<sup>2</sup>S bus
- internal clock oscillator
- full-feature mode by I<sup>2</sup>C control (three selectable subaddresses)
- reduced feature mode for non-I<sup>2</sup>C applications
- continuous sample rates from 8 kHz to 50 kHz
- analog deemphasis for 44.1 kHz
- analog volume and balance: +18...–75 dB and mute
- oversampling and multibit noise-shaping technique
- THD better than 0.01 %
- two additional analog stereo inputs (AUX) with source selection and mixing
- supply range: 2.7 V...5.5 V
- low-power mode
- additional line-out
- on-chip op amps for cost-effective external analog sound processing

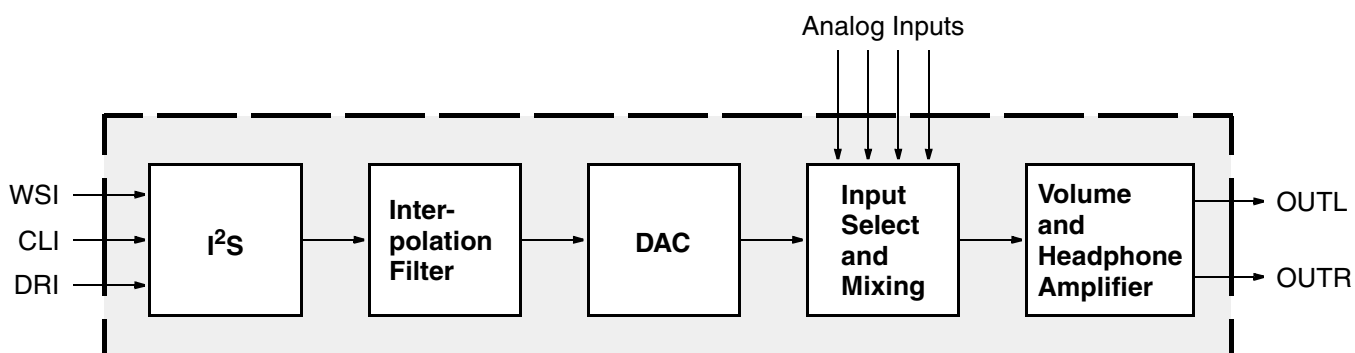

Fig. 1–1: Block diagram of the DAC 3550A

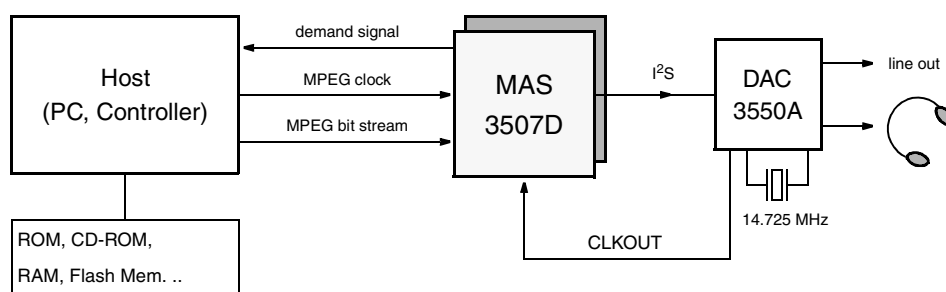

Fig. 1–2: Typical application: MPEG Layer 3 Player

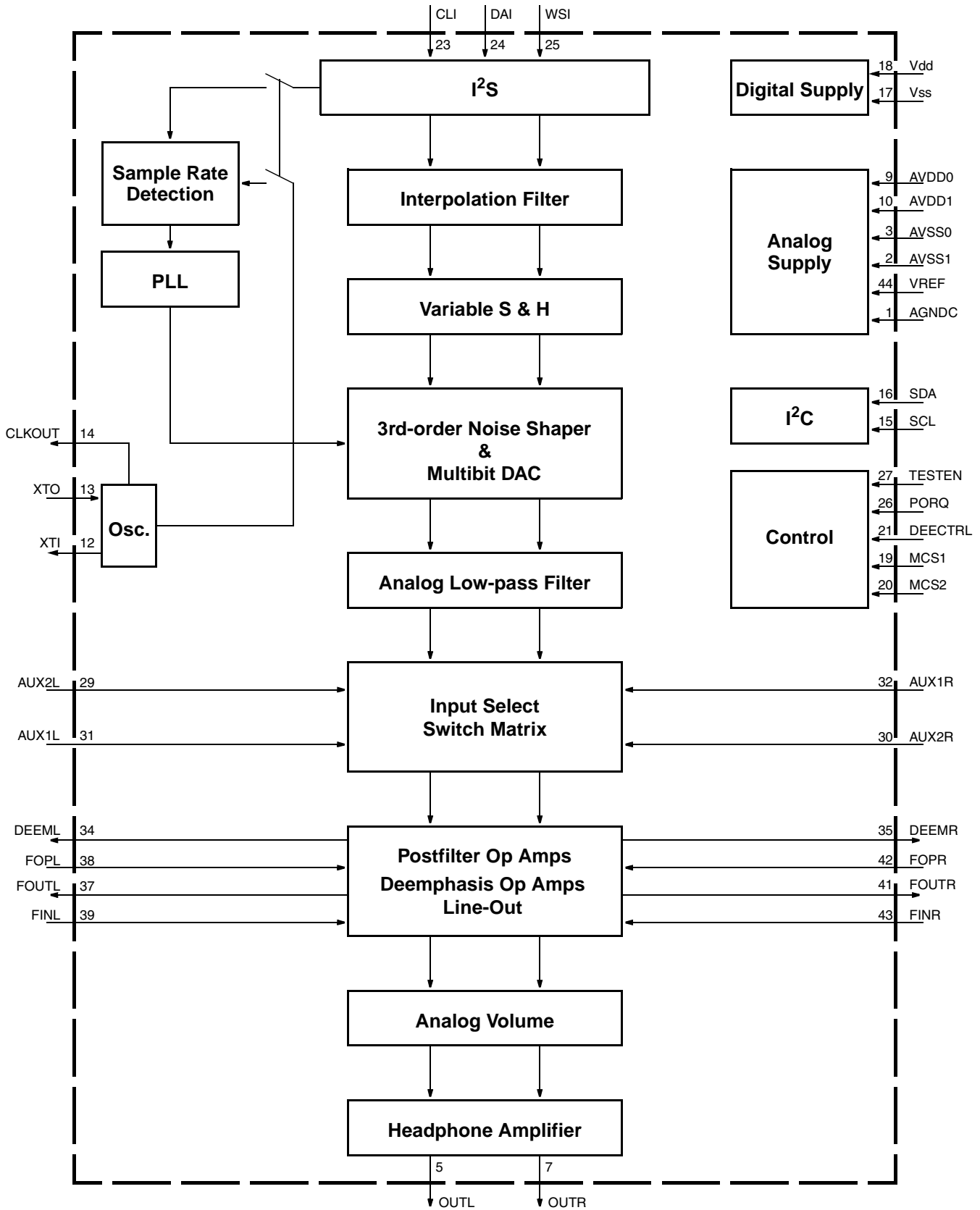

Fig. 1–3: Block diagram of the DAC 3550A

## 2. Functional Description

### 2.1. I<sup>2</sup>S Interface

The I<sup>2</sup>S interface is the digital audio interface between the DAC 3550A and external digital audio sources such as CD/DAT players, MPEG decoders etc. It covers most of the I<sup>2</sup>S-compatible formats.

All modes have two common features:

1. The MSB is left justified to an I<sup>2</sup>S frame identification (WSI) transition.
2. Data is valid on the rising edge of the bit clock CLI.

#### 16-bit mode

In this case, the bit clock is  $32 \times f_{s_{audio}}$ . Maximum word length is 16 bit.

#### 32-bit mode

In this case, the bit clock is  $64 \times f_{s_{audio}}$ . Maximum word length is 32 bit.

#### Automatic Detection

No I<sup>2</sup>C control is required to switch between 16- and 32-bit mode. It is recommended to switch the DAC 3550A into mute position during changing between 16- and 32-bit mode.

For high-quality audio, it is recommended to use the 32-bit mode of the I<sup>2</sup>S interface to make use of the full dynamic range (if more than 16 bits are available).

#### Left-Right Selection

Standard I<sup>2</sup>S format defines an audio frame always starting with left channel and low-state of WSI. However, I<sup>2</sup>C control allows changing the polarity of WSI.

#### Delay Bit

Standard I<sup>2</sup>S format requires a delay of one clock cycle between transitions of WSI and data MSB. In order to fit other formats, however, this characteristic can be switched off and on by I<sup>2</sup>C control.

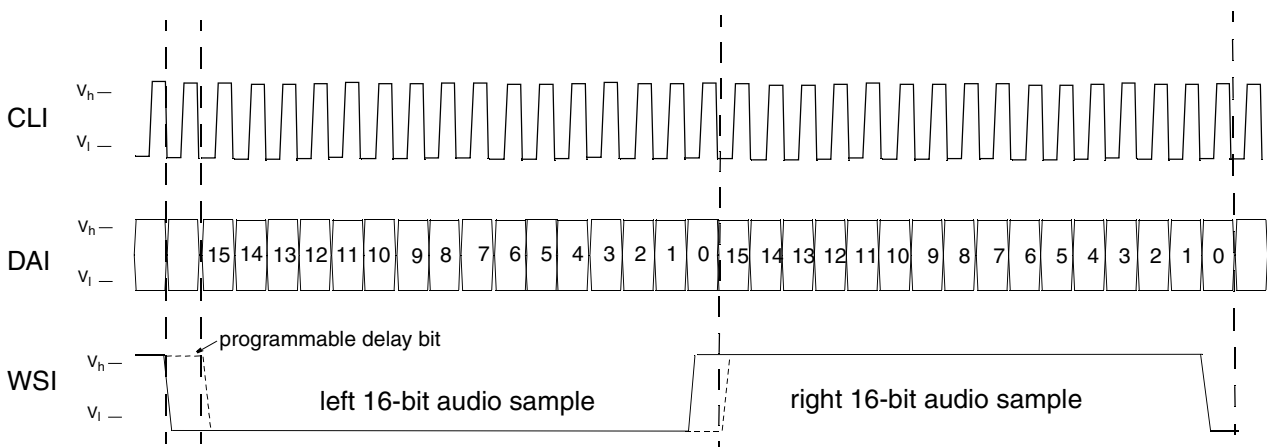

Fig. 2-1: I<sup>2</sup>S 16-bit mode (LR\_SEL=0)

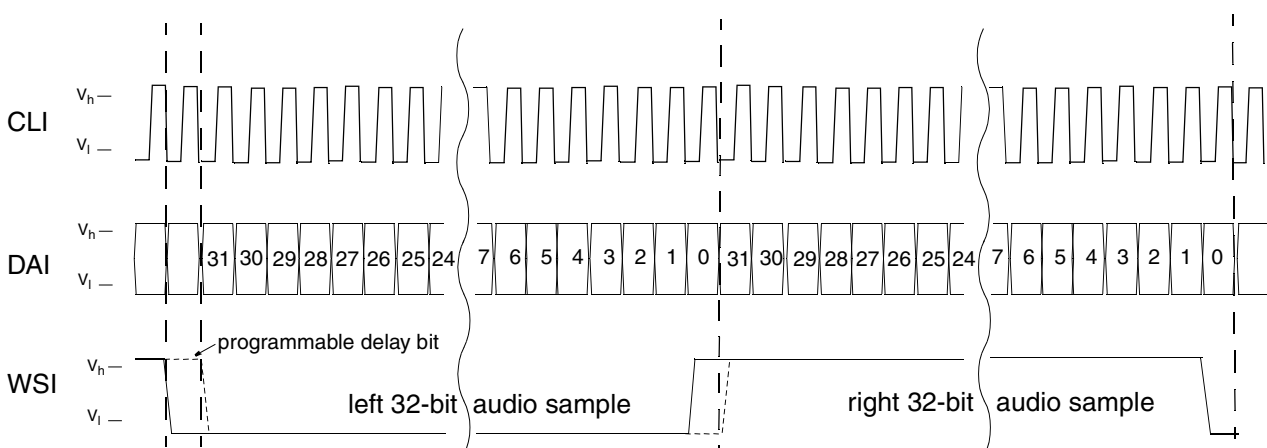
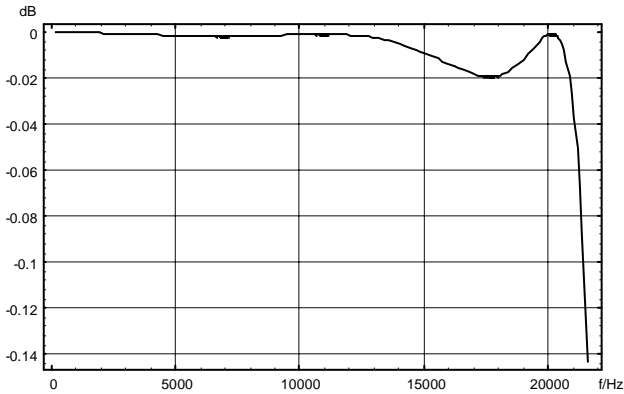

Fig. 2-2: I<sup>2</sup>S 32-bit mode (LR\_SEL=0)

**Note:** Volume mute should be applied before changing I<sup>2</sup>S mode in order to avoid audible clicks.

## 2.2. Interpolation Filter

The interpolation filter increases the sampling rate by a factor of 8. The characteristic for  $f_{s_{\text{audio}}} = 48 \text{ kHz}$  is shown in Fig. 2–3.



**Fig. 2–3:** 1→8 Interpolation filter; frequency range: 0...22 kHz

## 2.3. Variable Sample and Hold

The advantage of this system is that even at low sample frequencies the out-of-band noise is not scaled down to audible frequencies.

## 2.4. 3rd-order Noise Shaper and Multibit DAC

The 3rd-order noise shaper converts the oversampled audio signal into a 5-bit noise-shaping signal at a high sampling rate. This technique results in extremely low quantization noise in the audio band.

## 2.5. Analog Low-pass

The analog low-pass is a first order filter with a cut-off frequency of approximately 1.4 MHz which removes the high-frequency components of the noise-shaping signal.

## 2.6. Input Select and Mixing Matrix

This block is used to switch between or mix the auxiliary inputs and the signals coming from the DAC. A switch matrix allows to select between mono and stereo mode as shown in Fig. 2–4.

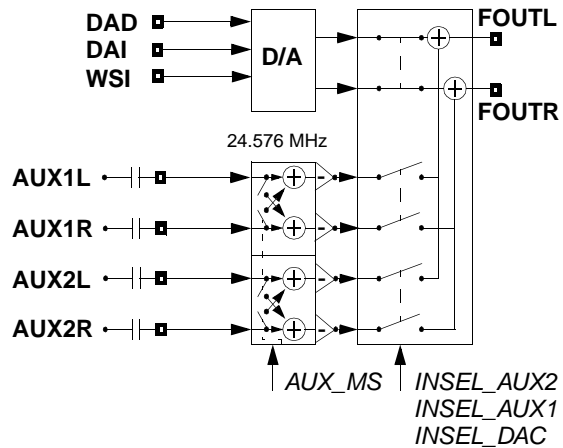

**Fig. 2–4:** Switch matrix

Mono mode is realized by adding left and right channel.

## 2.7. Postfilter Op Amps, Deemphasis Op Amps, and Line-Out

This block contains the active components for the analog postfilters and the deemphasis network. The op amps and all I/O-pins for this block are shown in Fig. 2–5.

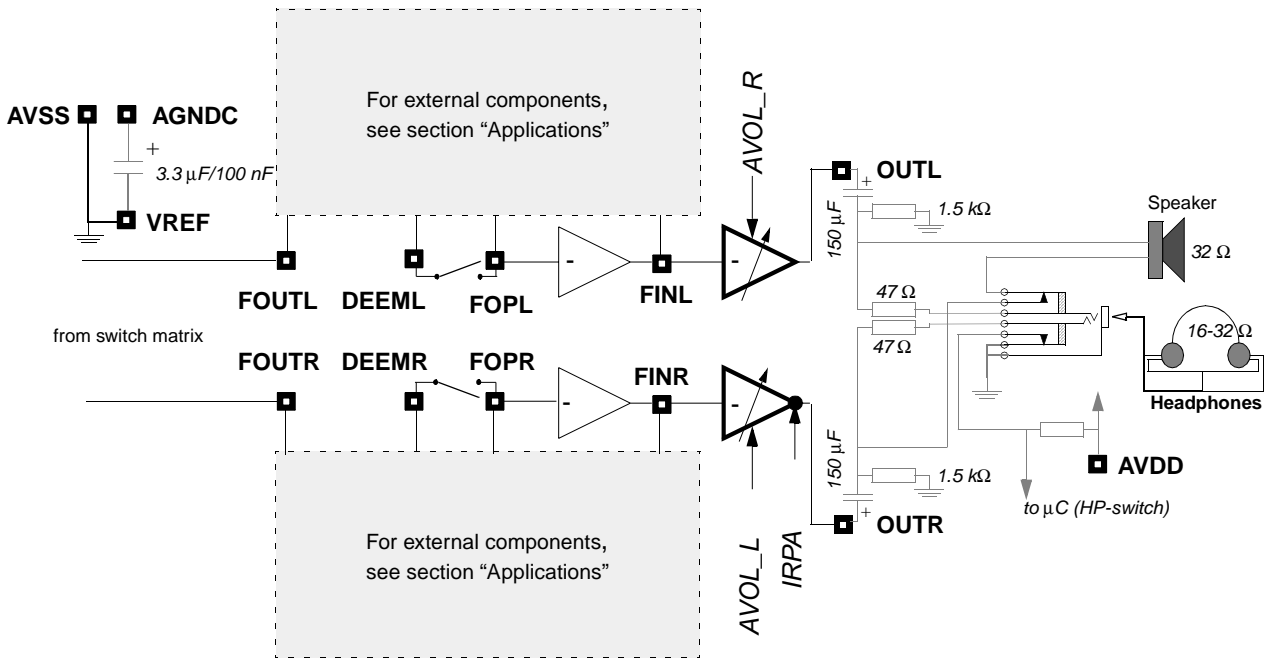

Fig. 2–5: Postfilter op amps, deemphasis op amps, and line-out

2.8. Analog Volume

The analog volume control covers a range from +18 dB to –75 dB. The lowest step is the mute position.

Step size is split into a 3-dB and a 1.5-dB range:

- 75 dB...–54 dB: 3 dB step size
- 54 dB...+18 dB: 1.5 dB step size

2.9. Headphone Amplifier

The headphone amplifier output is provided at the OUTL and OUTR pins connected either to stereo headphones or a mono loudspeaker. The stereo headphones require external 47-Ω serial resistors in both channels. If a loudspeaker is connected to these outputs, the power amplifier for the right channel must be switched to inverse polarity. In order to optimize the available power, the source of the two output amplifiers should be identical, i.e. a monaural signal.

Please note, that if a speaker is connected, it should strictly be connected as shown in Fig. 2–5. Never use a separate connector for the speaker, because electrostatic discharge could damage the output transistors.

Table 2–1: Volume Control

Volume/dB	AVOL
18.0	111000
16.5	110111
15.0	110110
13.5	110101
–	–
0.0	101100 (default)
–1.5	101011
–	–
–54.0	001000
–57.0	000111
–	–
–75	000001
Mute	000000

## 2.10. Clock System

The advantage of the DAC 3550A clock system is that no external master clock is needed. Most DACs need  $256 \times f_{s_{\text{audio}}}$ ,  $384 \times f_{s_{\text{audio}}}$ , or at least an asynchronous clock.

All internal clocks are generated by a PLL circuit, which locks to the I<sup>2</sup>S bit clock (CLI). If no I<sup>2</sup>S clock is present, the PLL runs free, and it is guaranteed that there is always a clock to keep the IC controllable by I<sup>2</sup>C.

The device can be set to two different modes:

- Standard mode
- MPEG mode

In the standard mode, I<sup>2</sup>C subaddressing is possible (ADR0, ADR1, ADR2). MPEG mode always uses ADR3.

To select the modes, the MCS1/MCS2 pins must be set according to Table 2–2.

**Table 2–2:** Operation Modes

MCS1	MCS2	Mode	Sub-address	Default Sample Rate
0	0	Standard	ADR0	32–48 kHz
0	1	Standard	ADR1	32–48 kHz
1	0	Standard	ADR2	32–48 kHz
1	1	MPEG	ADR3	Automatic

### 2.10.1. Standard Mode

– *without I<sup>2</sup>C*  
In standard mode, sample rates from 48 kHz to 32 kHz are handled without I<sup>2</sup>C control automatically. The setting for this range is the default setting.

– *with I<sup>2</sup>C*  
Sample rates below 32 kHz require an I<sup>2</sup>C control to set the PLL divider. This ensures that even at low sample rates, the DAC 3550A runs at a high clock rate. This avoids audible effects due to the noise-shaping technique of the DAC 3550A. Sample rate range is continuous from 8 to 50 kHz. The I<sup>2</sup>C setting of low sample rates must follow according to Section 3.6. “Control Registers” on page 15.

An additional mode allows automatic sample rate detection. In this case, the clock oscillator is required and must run at frequencies between 13.3 MHz to 17 MHz. This mode, however, does not support continuous sample rates. Only the following sample rates are allowed:

8 kHz, 11.025 kHz, 12 kHz, 16 kHz, 22.05 kHz, 24 kHz, 32 kHz, 44.1 kHz, 48 kHz

The sample rate detection allows a tolerance of  $\pm 200$  ppm at WSI.

If the oscillator is not used for automatic sample rate detection, it can be used as a general-purpose clock for the application. The frequency range in this case is 10 MHz to 25 MHz.

### 2.10.2. MPEG Mode

This mode should be used in conjunction with MAS 3507D in MPEG player applications. In this case a 14.725 MHz signal is needed to provide a clock for the MAS 3507D and to allow an automatic sample rate detection in the DAC 3550A. All MPEG sample rates from 8 to 48 kHz can be detected. The internal processing and the DAC itself are automatically adjusted to keep constant performance throughout the entire range. I<sup>2</sup>C control for sample rate adjustment is not needed in this case. Register SR\_REG[0:2] is locked to SRC\_A; see Section 3.6. “Control Registers” on page 15.

The MPEG sample rates:

8 kHz, 11.025 kHz, 12 kHz, 16 kHz, 22.05 kHz, 24 kHz, 32 kHz, 44.1 kHz, 48 kHz

As in standard mode, the sample rate detection allows a tolerance of  $\pm 200$  ppm at WSI.

Subaddressing is not possible in MPEG mode; this means, in multi-DAC systems, only one DAC 3550A can run in MPEG mode.



### 2.11. I<sup>2</sup>C Bus Interface

The DAC 3550A is equipped with an I<sup>2</sup>C bus slave interface. The I<sup>2</sup>C bus interface uses one level of sub-addressing: The I<sup>2</sup>C bus address is used to address the IC. The subaddress allows chip select in multi DAC applications and selects one of the three internal registers. The registers are write-only. The I<sup>2</sup>C bus chip address is given below.

dev\_write = \$9A.

The registers of the DAC 3550A have 8- or 16-bit data size; 16-bit registers are accessed by writing two 8-bit data words.

A6	A5	A4	A3	A2	A1	A0	R/W
1	0	0	1	1	0	1	0

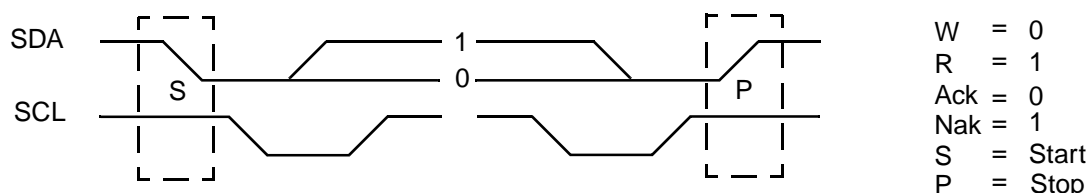
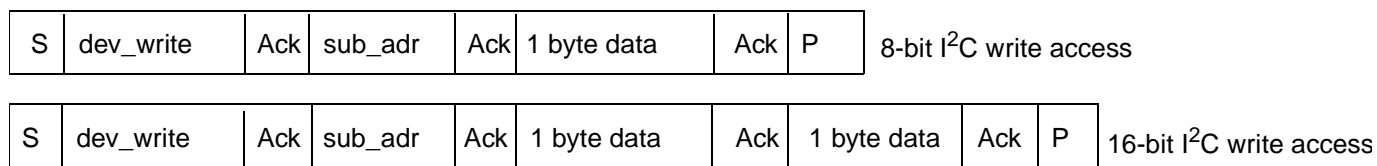

Fig. 2-6: I<sup>2</sup>C bus protocols for write operations

### 2.12. Registers

In Section 3.6. “Control Registers” on page 15, a definition of the DAC 3550A control registers is shown. A hardware reset initializes all control registers to 0. The automatic chip initialization loads a selected set of registers with the default values given in the table.

All registers are write-only.

The register address is coded by 3 bits (RA1, RA0) according to Table 2-3.

Table 2-3: I<sup>2</sup>C Register Address

RA1	RA0	Mnemonics
0	1	SR_REG
1	0	AVOL
1	1	GCFG

The mnemonics used in the DAC 3550A demo software of Micronas are given in the last column.

### 2.13. Chip Select

Chip select allows to connect up to four DAC 3550A to an I<sup>2</sup>C control bus. The chip subaddresses are defined by the MCS1/MCS2 (Mode and Chip Select) pins. Only in standard mode, chip select is possible. MPEG mode always uses chip subaddress 3.

Register address and chip select are mapped into the subaddress field in Table 2-4.

### 2.14. Reduced Feature Mode

If I<sup>2</sup>C control is not used, the IC is in the default mode (see Section 3.6. “Control Registers” on page 15) after start-up. Default Volume setting is 0 dB and digital audio input is set to standard I<sup>2</sup>S. Sample rates from 32 kHz to 48 kHz are supported in this mode. Applications with no need for volume control or analog input could use this mode.

Table 2-4: I<sup>2</sup>C Subaddress

7	6	5	4	3	2	1	0
MCS2	MCS1					RA1	RA0

## 3. Specifications

### 3.1. Outline Dimensions

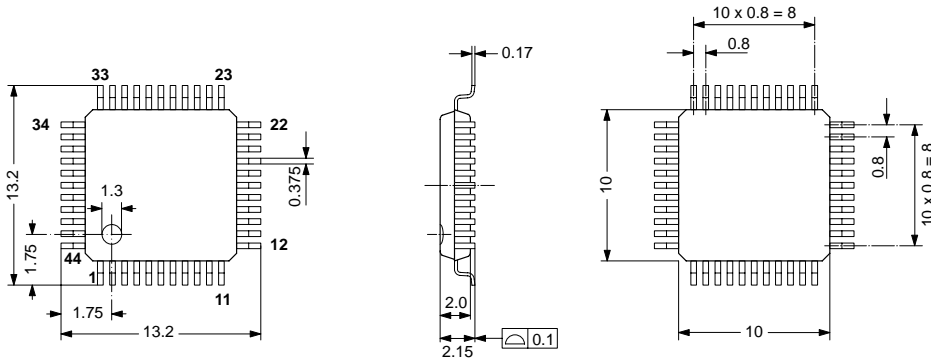

D0024/2E

**Fig. 3-1:**  
44-Pin Plastic Metric Quad Flat Package  
(PMQFP44)  
Weight approximately 0.4 g  
Dimensions in mm

### 3.2. Pin Connections and Short Descriptions

NC = not connected, leave vacant  
LV = if not used, leave vacant  
VSS = if not used, connect to VSS

X = obligatory; connect as described in application diagram  
VDD = connect to VDD

Pin No.	Pin Name	Type	Connection (if not used)	Short Description
1	AGNDC	IN/OUT	X	Analog reference Voltage
2	AVSS1	IN	X	VSS 1 for audio back-end
3	AVSS0	IN	X	VSS 0 for audio output amplifiers
4	NC		LV	Not connected
5	OUTL	OUT	LV	Audio Output: Headphone left or Speaker +
6	NC		LV	Not connected
7	OUTR	OUT	LV	Audio Output: Headphone right or Speaker -
8	NC		LV	Not connected
9	AVDD0	IN	X	VDD 0 for audio output amplifiers
10	AVDD1	IN	X	VDD 1 for audio back-end
11	NC		LV	Not connected
12	XTI	IN	X	Quartz oscillator pin 1
13	XTO	IN/OUT	X	Quartz oscillator pin 2
14	CLKOUT	OUT	LV	Clock Output
15	SCL	IN/OUT	LV	I <sup>2</sup> C clock

Pin No.	Pin Name	Type	Connection (if not used)	Short Description
16	SDA	IN/OUT	LV	I <sup>2</sup> C data
17	VSS	IN	X	Digital VSS
18	VDD	IN	X	Digital VDD
19	MCS1	IN	X	I <sup>2</sup> C Chip Select 1
20	MCS2	IN	X	I <sup>2</sup> C Chip Select 2
21	DEECTRL	IN	VSS	Deemphasis on/off Control
22	NC		LV	Not connected
23	CLI		VSS	I <sup>2</sup> S Bit Clock
24	DAI	IN	VSS	I <sup>2</sup> S Data
25	WSI	IN	VSS	I <sup>2</sup> S Frame Identification
26	PORQ	IN	VDD	Power-On Reset, active-low
27	TESTEN	IN	X	Test Enable
28	NC		LV	Not connected
29	AUX2L	IN	LV	AUX2 left input for external analog signals (e.g. tape)
30	AUX2R	IN	LV	AUX2 right input for external analog signals (e.g. tape)
31	AUX1L	IN	LV	AUX1 left input for external analog signals (e.g. FM)
32	AUX1R	IN	LV	AUX1 right input for external analog signals (e.g. FM)
33	NC		LV	Not connected
34	DEEML	OUT	LV	Deemphasis Network Left
35	DEEMR	OUT	LV	Deemphasis Network Right
36	NC		LV	Not connected
37	FOUTL	OUT	X	Output to left external filter
38	FOPL	IN/OUT	X	Filter op amp inverting input, left
39	FINL	IN/OUT	X	Input for FOUTL or filter op amp output (line out)
40	NC		LV	Not connected
41	FOUR	OUT	X	Output to right external filter
42	FOPR	IN/OUT	X	Right Filter op amp inverting input
43	FINR	IN/OUT	X	Input for FOUR or filter op amp output (line out)
44	VREF	IN	X	Analog reference Ground

## 3.3. Pin Descriptions

### 3.3.1. Power Supply Pins

The DAC 3550A combines various analog and digital functions which may be used in different modes. For optimized performance, major parts have their own power supply pins. All VSS power supply pins must be connected.

#### VDD (18)

#### VSS (17)

The VDD and VSS power supply pair are connected internally with all digital parts of the DAC 3550A.

#### AVDD0 (9)

#### AVSS0 (3)

AVDD0 and AVSS0 are separate power supply pins that are exclusively used for the on-chip headphone/loudspeaker amplifiers.

#### AVDD1 (10)

#### AVSS1 (2)

The AVDD1 and AVSS1 pins supply the analog audio processing parts, except for the headphone/loudspeaker amplifiers.

### 3.3.2. Analog Audio Pins

#### AGNDC (1)

Reference for analog audio signals. This pin is used as reference for the internal op amps. This pin must be blocked against VREF with a 3.3  $\mu$ F capacitor.

**Note:** The pin has a typical DC-level of 1.5/2.25 V. It can be used as reference input for external op amps when no current load is applied.

#### VREF (44)

Reference ground for the internal band-gap and biasing circuits. This pin should be connected to a clean ground potential. Any external distortions on this pin will affect the analog performance of the DAC 3550A.

#### AUX1L (31)

#### AUX1R (32)

#### AUX2L (29)

#### AUX2R (30)

The AUX pins provide two analog stereo inputs. Auxiliary input signals, e.g. the output of a conventional receiver circuit or the output of a tape recorder can be connected with these inputs. The input signals have to be connected by capacitive coupling.

#### FOUTL (37)

#### FOPL (38)

#### FINL (39)

#### FOUR (41)

#### FOPR (42)

#### FINR (43)

Filter op amps are provided in the analog baseband signal paths. These inverting op amps are freely accessible for external use by these pins.

The FOUTL/R pins are connected with the buffered output of the internal switch matrix. The FOPL/R-pins are directly connected with the inverting inputs of the filter op amps. The FINL/R pins are connected with the outputs of the op amps. The driving capability of the FOUTL/R pins is not sufficient for standard line output signals. Only the FINL/R pins are suitable for line output.

#### OUTL (5)

#### OUTR (7)

The OUTL/R pins are connected to the internal output amplifiers. They can be used for either stereo headphones or a mono loudspeaker. The signal of the right channel amplifier can be inverted for mono loudspeaker operation.

**Caution:** A short circuit at these pins for more than a momentary period may result in destruction of the internal circuits.

### 3.3.3. Oscillator and Clock Pins

#### XTI (12)

#### XTO (13)

The XTI pin is connected to the input of the internal crystal oscillator, the XTO pin to its output. Both pins should be directly connected to the crystal and two ground-connected capacitors (see application diagram).

#### CLKOUT (14)

The CLKOUT pin provides a buffered output of the crystal oscillator.

**Caution:** Power dissipation limit may be exceeded in case of short to VSS or VDD.

#### CLI (23)

#### DAI (24)

#### WSI (25)

These three pins are inputs for the digital audio data DAI, frame indication signal WSI, and bit clock CLI. The digital audio data is transmitted in an I<sup>2</sup>S-compatible format. Audio word lengths of 16 and 32 bits are supported, as well as SONY and Philips I<sup>2</sup>S protocol.

#### SCL (15)

#### SDA (16)

SCL (serial clock) and SDA (serial data) provide the connection to the serial control interface (I<sup>2</sup>C).

3.3.4. Other Pins

**TESTEN (27)**

Test enable. This pin is for test purposes only and must always be connected to VSS.

**PORQ (26)**

This pin may be used to reset the chip. If not used, this pin must be connected to VDD.

**DEEML (34)**

**DEEMR (35)**

These pins connect an external analog deemphasis network to the signal path in the analog back-end. This connection can be switched on and off by an internal switch which is controlled either by I<sup>2</sup>C or the DEECTRL-pin.

**DEECTRL (21)**

If no I<sup>2</sup>C-control is used, deemphasis can be switched on and off with this pin.

**MCS1 (19)**

**MCS2 (20)**

Mode select pins to select MPEG, Standard Mode, and I<sup>2</sup>C subaddress.

3.4. Pin Configuration

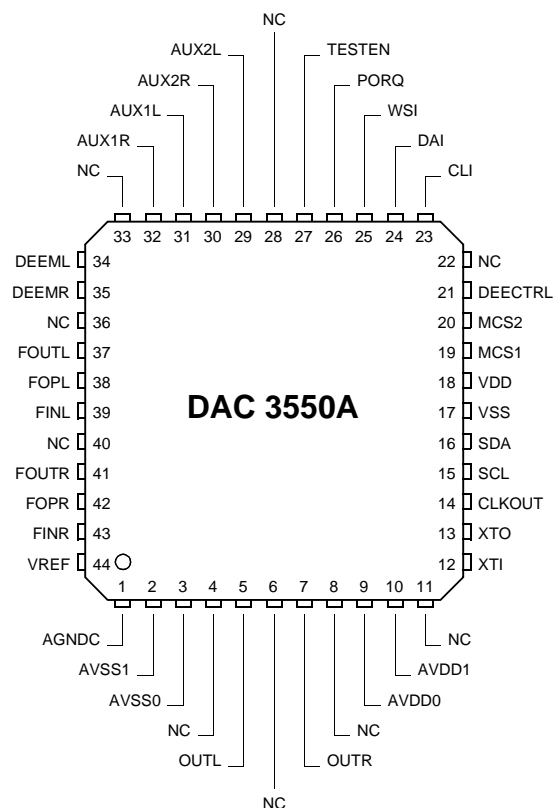
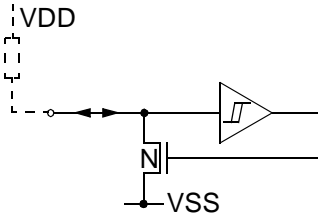
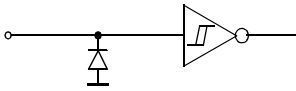

Fig. 3–2: 44-pin PMQFP package

## 3.5. Pin Circuits



**Fig. 3-3:** Input/Output Pins SDA, SCL



**Fig. 3-4:** Input Pins DAI, WSI, PORQ, CLI

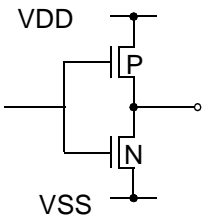

**Fig. 3-5:** Output Pin CLKOUT

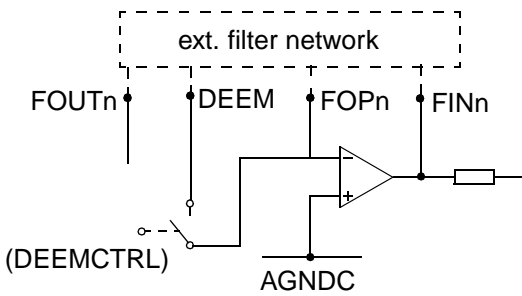

**Fig. 3-6:** Pins FINR, FOPR, FINL, FOPL, DEEML, DEEMR

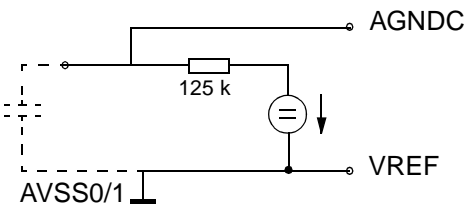

**Fig. 3-7:** Pins AGND, VREF

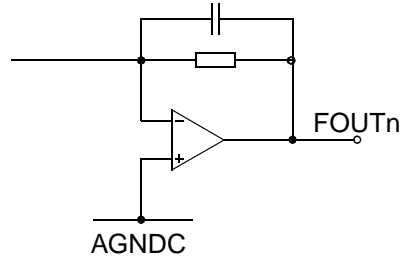

**Fig. 3-8:** Output Pins FOUTL, FOUTR

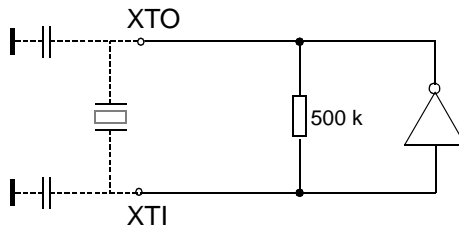

**Fig. 3-9:** Input/Output Pins XTI, XTO

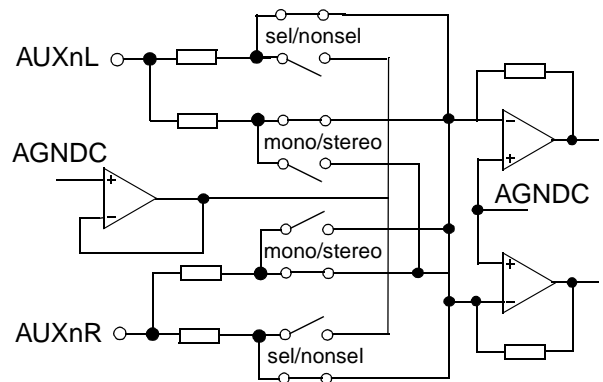

**Fig. 3-10:** Input Pins AUX1R, AUX1L, AUX2R, AUX2L, AGND

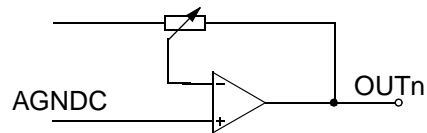

**Fig. 3-11:** Output Pins OUTL, OUTR

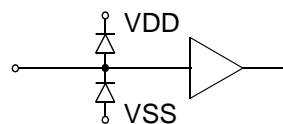

**Fig. 3-12:** Input Pins MCS1, MCS2, DEECTRL

## 3.6. Control Registers

I <sup>2</sup> C Sub-address (hex)	Number of Bits	Mode	Function	Default Values (hex)	Name
<b>SAMPLE RATE CONTROL SR_REG</b>					
01	8	w	sample rate control bit[7:5] not used, set to 0 bit[4] L/R-bit 0 (WSI = 0 → left channel) <sup>1)</sup> 1 (WSI = 0 → right channel) <sup>1)</sup> bit[3] Delay-Bit 0 No Delay 1 1 bit Delay bit[2:0] sample rate control 000 32–48 kHz 001 26–32 kHz 010 20–26 kHz 011 14–20 kHz 100 10–14 kHz 101 8–10 kHz 11x <sup>2)</sup> autoselect	0H	LR_SEL  SP_SEL  SRC_48 SRC_32 SRC_24 SRC_16 SRC_12 SRC_8 SRC_A
<b>ANALOG VOLUME AVOL</b>					
02	16	w	audio volume control bit[15] not used, set to 0 bit[14] deemphasis on/off 0 deemphasis off 1 deemphasis on bit[13:8] analog audio volume level left: 000000 mute 000001 –75 dB 101100 +0 dB (default) 111000 +18 dB bit[7:6] not used, set to 0 bit[5:0] analog audio volume level right 000000 mute 000001 –75 dB 101100 +0 dB (default) 111000 +18 dB	2C2CH	DEEM  AVOL_L  AVOL_R
<sup>1)</sup> see Fig. 2–1 and Fig. 2–2 on page <sup>5</sup> <sup>2)</sup> don't care					

# DAC 3550A

I <sup>2</sup> C Sub-address (hex)	Number of Bits	Mode	Function	Default Values (hex)	Name
Global Configuration <b>GCFG</b>					
03	8	w	global configuration bit[7] not used, set to 0 bit[6] select 3V-5 V mode 0 3 V 1 5 V bit[5] power-mode 0 normal 1 low power bit[4] AUX2 select 0 AUX2 off 1 AUX2 on bit[3] AUX1 select 0 AUX1 off 1 AUX1 on bit[2] DAC select 0 DAC off 1 DAC on (default) bit[1] aux-mono/stereo 0 stereo 1 mono bit[0] invert right power amplifier 0 not inverted 1 inverted	4H	SEL_53V  PWMD  INSEL_AUX2  INSEL_AUX1  INSEL_DAC  AUX_MS  IRPA



### 3.7. Electrical Characteristics

#### 3.7.1. Absolute Maximum Ratings

Symbol	Parameter	Pin Name	Min.	Max.	Unit
$T_A$	Ambient Operating Temperature <sup>1)</sup>		0	70	°C
$T_S$	Storage Temperature		-40	125	°C
$P_{max}$	Power Dissipation			500	mW
$V_{SUPA}$	Analog Supply Voltage <sup>2)</sup>	AVDD0/1	-0.3	6	V
$V_{SUPD}$	Digital Supply Voltage	VDD	-0.3	6	V
$V_{Idig1}$	Input Voltage, digital inputs	MCS1, MCS2, DEECTRL	-0.3	$V_{SUPD} + 0.3$	V
$V_{Idig2}$	Input Voltage, digital inputs	WSI, CLI, DAI, PORQ, SCL, SDA	-0.3	6	V
$I_{Idig}$	Input Current, all digital inputs		-5	+5	mA
$V_{Iana}$	Input Voltage, all analog inputs		-0.3	$V_{SUPA} + 0.3$	V
$I_{Iana}$	Input Current, all analog inputs		-5	+5	mA
$I_{Oaudio}$	Output Current, audio output <sup>3)</sup>	OUTL/R	-0.2	0.2	A
$I_{Odig}$	Output Current, all digital outputs <sup>4)</sup>		-10	10	mA
<p>1) =standard temperature range, DAC 3550A tested in extended temperature range on request  2) Both have to be connected together!  3) These pins are NOT short-circuit proof!  4) Total chip power dissipation must not exceed absolute maximum rating</p>					

Stresses beyond those listed in the “Absolute Maximum Ratings” may cause permanent damage to the device. This is a stress rating only. Functional operation of the device at these or any other conditions beyond those indicated in the “Recommended Operating Conditions/Characteristics” of this specification is not implied. Exposure to absolute maximum ratings conditions for extended periods may affect device reliability.

# DAC 3550A

## 3.7.2. Recommended Operating Conditions

Symbol	Parameter	Pin Name	Min.	Typ.	Max.	Unit
Temperature Ranges and Supply Voltages						
$T_A$	Ambient Temperature Range <sup>1)</sup>		0		70	°C
$V_{SUPA1}$	Analog Audio Supply Voltage	AVDD0/1	3.0 <sup>2)</sup>	3.3	5.5	V
$V_{SUPD}$	Digital Supply Voltage	VDD	2.7	3.3	5.5	V
Relative Supply Voltages						
$V_{SUPA}$	Analog Audio Supply Voltage in relation to the Digital Supply Voltage	AVDD0/1	$V_{SUPD} - 0.25\text{ V}$		5.5 V	
Analog Reference						
$C_{AGNDC1}$	Analog Reference Capacitor	AGNDC	1.0	3.3		μF
$C_{AGNDC2}$	Analog Reference Capacitor	AGNDC		10		nF
Analog Audio Inputs						
$V_{AI}$	Analog Input Voltage AC, SEL_53V = 0	AUXnL/R <sup>3)</sup>		0.35	0.7	$V_{rms}$
$V_{AI}$	Analog Input Voltage AC, SEL_53V = 1	AUXnL/R <sup>3)</sup>		0.525	1.05	$V_{rms}$
Analog Filter Input and Output						
$Z_{AFLO}$	Analog Filter Load Output <sup>4)</sup>	FOUTL/R	7.5		6	kΩ pF
$Z_{AFLI}$	Analog Filter Load Input <sup>4)</sup>	FINL/R	5.0		7.5	kΩ pF
Analog Audio Output						
$Z_{LO}$	Audio Line Output <sup>5)</sup> (680 Ω Series Resistor required)	FINL/R	10		1.0	kΩ nF
$Z_{AOL\_HP}$	Analog Output Load HP (47 Ω Series Resistor required)	OUTL/R		32 400		Ω pF
$Z_{AOL\_SP}$	Analog Output Load SP (bridged)	OUTL/R		32 50		Ω pF
	Analog Output Load SP (Stereo)			16 100		Ω pF
<sup>1)</sup> =standard temperature range, DAC 3550A tested in extended temperature range on request <sup>2)</sup> typically operable down to 2.7 V, without loss in performance <sup>3)</sup> n = 1 or 2 <sup>4)</sup> Please refer to Section 4.2. "Recommended Low-Pass Filters for Analog Outputs" on page 25. <sup>5)</sup> Please refer to Section 4.1. "Line Output Details" on page 25.						

Symbol	Parameter	Pin Name	Min.	Typ.	Max.	Unit
I <sup>2</sup> C Input						
f <sub>I2C1</sub>	I <sup>2</sup> C Clock Frequency, I <sup>2</sup> S active	SCL		400		kHz
f <sub>I2C2</sub>	I <sup>2</sup> C Clock Frequency, I <sup>2</sup> S inactive			100		kHz
Digital Inputs						
V <sub>IH</sub>	Input High Voltage	CLI, WSI, DAI, PORQ, SCL, SDA	0.5× VDD			V
V <sub>IL</sub>	Input Low Voltage				0.2× VDD	
Quartz Characteristics						
F <sub>P</sub>	Load Resonance Frequency at C <sub>1</sub> = 20 pF		13.3	14.725	17	MHz
R <sub>EQ</sub>	Equivalent Series Resistance			12	30	Ω
C <sub>0</sub>	Shunt (parallel) Capacitance			3	5	pF
Load at CLKOUT Output						
C <sub>load</sub>	Capacitance	CLKOUT	0		50	pF
1) =standard temperature range, DAC 3550A tested in extended temperature range on request 2) typically operable down to 2.7 V, without loss in performance 3) n = 1 or 2 4) Please refer to Section 4.2. “Recommended Low-Pass Filters for Analog Outputs” on page 25. 5) Please refer to Section 4.1. “Line Output Details” on page 25.						

# DAC 3550A

## 3.7.3. Characteristics

At  $T_A = 0$  to  $70\text{ }^\circ\text{C}^*$ ,  $V_{\text{SUPD}} = 2.7$  to  $5.5\text{ V}$ ,  $V_{\text{SUPA}} = 3.0$  to  $5.5\text{ V}$ ; typical values at  $T_J = 27\text{ }^\circ\text{C}$ ,  $V_{\text{SUPD}} = V_{\text{SUPA}} = 3.3\text{ V}$ , quartz frequency =  $14.725\text{ MHz}$ , duty cycle =  $50\%$ , positive current flows into the IC

Symbol	Parameter	Pin Name	Min.	Typ.	Max.	Unit	Test Conditions
Digital Supply							
$I_{\text{VDD}}$	Current Consumption	VDD		5		mA	$V_{\text{SUPD}}=3\text{ V}$
$I_{\text{VDD}}$	Current Consumption	VDD		8		mA	$V_{\text{SUPD}}=5\text{ V}$
Digital Input Pin – Leakage							
$I_{\text{I}}$	Input Leakage Current	CLI, WSI, DAI, TESTEN, PORQ, DEECTRL, MCS1/2			$\pm 1$	$\mu\text{A}$	$V_{\text{GND}} \leq V_{\text{I}} \leq V_{\text{SUP}}$
Digital Output Pin – Clock Out							
$V_{\text{OH}}$	Output High Voltage	CLKOUT	$V_{\text{SUPD}} - 0.3$			V	no load at output
$V_{\text{OL}}$	Output Low Voltage				0.3	V	
$I^2\text{C}$ Bus							
$R_{\text{on}}$	Output Impedance	SCL, SDA			60	$\Omega$	$I_{\text{load}} = 5\text{ mA}$ , $V_{\text{SUPD}} = 2.7\text{ V}$
Analog Supply							
$I_{\text{AVDD}}$	Current Consumption Analog Audio, SEL_53V = 0	AVDD0/1		8 1.5	11	mA mA	PWMD = 0, Mute PWMD = 1, Mute
	SEL_53V = 1			11 2	15	mA mA	PWMD = 0, Mute PWMD = 1, Mute
$\text{PSRR}_{\text{AA}}$	Power Supply Rejection Ratio for Analog Audio Output	AVDD0/1, OUTL/R		50		dB	1 kHz sine at $100\text{ mV}_{\text{rms}}$
				20		dB	$\leq 100\text{ kHz}$ sine at $100\text{ mV}_{\text{rms}}$
$\text{PSRR}_{\text{LO}}$	Power Supply Rejection Ratio for Line Output	AVDD0/1, FINL/R		50		dB	1 kHz sine at $100\text{ mV}_{\text{rms}}$
				40		dB	$\leq 100\text{ kHz}$ sine at $100\text{ mV}_{\text{rms}}$
Reference Frequency Generation							
$V_{\text{DCXTI}}$	DC Voltage at Oscillator Pins	XTI/O		$0.5 \cdot V_{\text{SUPA}}$		V	
$C_{\text{LI}}$	Input Capacitance at Oscillator Pin	XTI/O		3		pF	
$V_{\text{xtalout}}$	Voltage Swing at Oscillator Pins, pp	XTI/O	60		100	% $V_{\text{SUPA}}$	
	Oscillator Start-Up Time				50	ms	$V_{\text{DD}}/V_{\text{DD}} \geq 2.5\text{ V}$

\* =standard temperature range, DAC 3550A tested in extended temperature range on request

Symbol	Parameter	Pin Name	Min.	Typ.	Max.	Unit	Test Conditions
Analog Audio							
V <sub>AO</sub>	Analog Output Voltage AC	OUTL/R, FOUTL/R, FINL/R	0.65	0.7	0.75	V <sub>rms</sub>	SEL_53V = 0, R <sub>L</sub> > 5 kΩ, Analog Gain = 0 dB Input = 0 dBFS digital
			1.0	1.05	1.1	V <sub>rms</sub>	SEL_53V = 1
G <sub>AUX</sub>	Gain from Auxiliary Inputs to Line Outputs	AUXnL/R, FINL/R	-0.5	0	0.5	dB	f = 1 kHz, sine wave, R <sub>L</sub> > 5 kΩ 0.5 V <sub>rms</sub> to AUXnL/R
P <sub>HP</sub>	Output Power (Headphone)	OUTL/R		5		mW	SEL_53V = 0, R <sub>L</sub> = 32 Ω, Analog Gain = +3 dB, distortion < 1%, external 47 Ω series resistor required
				12		mW	SEL_53V = 1
P <sub>SP</sub>	Output Power (Speaker)	OUTL/R		120		mW	R <sub>L</sub> = 32 Ω (bridged), Analog Gain = +3 dB, distortion < 10%, SEL_53V = 0, IRPA = 1
				280		mW	SEL_53V = 1
G <sub>AO</sub>	Analog Output Gain Setting Range	OUTL/R	-75		18	dB	
dG <sub>AO1</sub>	Analog Output Gain Step Size	OUTL/R		3.0		dB	Analog Gain: -75 dB...-54 dB
dG <sub>AO2</sub>	Analog Output Gain Step Size	OUTL/R		1.5		dB	Analog Gain: -54 dB...+18 dB
E <sub>GA1</sub>	Analog Output Gain Error	OUTL/R	-2		2	dB	-46.5 dB ≥ Analog Gain ≥ -54 dB
E <sub>GA2</sub>	Analog Output Gain Error	OUTL/R	-1		1	dB	-40.5 dB ≥ Analog Gain ≥ -45 dB
E <sub>GA3</sub>	Analog Output Gain Error	OUTL/R	-0.5		0.5	dB	+18 dB ≥ Analog Gain ≥ -39 dB
E <sub>dGA</sub>	Analog Output Gain Step Size Error	OUTL/R	-0.5		0.5	dB	+18 dB ≥ Analog Gain ≥ -48 dB
SNR <sub>AUX</sub>	Signal-to-Noise Ratio from Analog Input to Line Output	AUXn, FINL/R		98		dB	SEL_53V = 0: input -40 dB below 0.7 V <sub>rms</sub> Analog Gain = 0 dB, BW = 20 Hz...20 kHz unweighted
	Signal-to-Noise Ratio from Analog Input to Headphone Output	AUXn, OUTn		93		dB	

# DAC 3550A

Symbol	Parameter	Pin Name	Min.	Typ.	Max.	Unit	Test Conditions
SNR <sub>1</sub>	Signal-to-Noise Ratio	OUTL/R	89	91		dB	R <sub>L</sub> ≥ 32 Ω (external 47 Ω series resistor required) BW = 20 Hz...0.5 fs unweighted, Analog Gain = 0 dB, Input = -20 dBFS
		FINL/R	90	92		dB	R <sub>L</sub> ≥ 5 kΩ, R <sub>dec</sub> ≥ 612 Ω BW etc. as above 16 bit I <sup>2</sup> S, SEL_53V = 0
				94		dB	32 bit I <sup>2</sup> S, SEL_53V = 0
				96		dB	16 bit I <sup>2</sup> S, SEL_53V = 1
				98		dB	32 bit I <sup>2</sup> S, SEL_53V = 1
				103		dB	32 bit I <sup>2</sup> S, SEL_53V = 1
SNR <sub>2</sub>	Signal-to-Noise Ratio	OUTL/R	58	62		dB	R <sub>L</sub> ≥ 32 Ω (external 47 Ω series resistor required) BW = 20 Hz...0.5 fs unweighted Analog Gain = -40.5 dB, Input = -3 dBFS
Lev <sub>Mute</sub>	Mute Level	OUTL/R		-110		dBV	BW = 20 Hz...22 kHz unweighted, no digital input signal, Analog Gain = Mute
R <sub>D/A</sub>	D/A Pass Band Ripple	OUTL/R, FOUTL/R		-0.1		dB	0...0.446 fs (no external filters used)
A <sub>D/A</sub>	D/A Stop Band Attenuation			40		dB	0.55...7.533 fs (no external filters used)
BW <sub>AUX</sub>	Bandwidth for Auxiliary Inputs	AUXnL/R, FINL/R		760		kHz	(no external filters used)
THD <sub>ALO</sub>	Total Harmonic Distortion from Auxiliary Inputs to Line Outputs	AUXnL/R, FINL/R			0.01	%	BW = 20 Hz...22 kHz, unweighted, R <sub>L</sub> > 5 kΩ Input 1 kHz at 0.5 V <sub>rms</sub> R <sub>dec</sub> ≥ 612 Ω
THD <sub>DLO</sub>	Total Harmonic Distortion (D/A converter to Line Output)	FINL/R			0.01	%	BW = 20 Hz...0.5 fs, unweighted, R <sub>L</sub> > 5 kΩ Input 1 kHz at -3 dBFS R <sub>dec</sub> ≥ 612 Ω
THD <sub>HP</sub>	Total Harmonic Distortion (Headphone)	OUTL/R			0.05	%	BW = 20 Hz...0.5 fs, unweighted, R <sub>L</sub> ≥ 32 Ω (47 Ω series resistor required), Analog Gain = 0 dB, Input 1 kHz at -3 dBFS

Symbol	Parameter	Pin Name	Min.	Typ.	Max.	Unit	Test Conditions
THD <sub>SP</sub>	Total Harmonic Distortion (Speaker)	OUTL/R			0.5	%	BW = 20 Hz...0.5 fs, unweighted, R <sub>L</sub> ≥ 32 Ω (speaker bridged), Analog Gain = 0 dB, Input 1 kHz at -3 dBFS
XTALK <sub>LO</sub>	Cross-Talk Left/Right Channel (Line Output)	AUXnL/R, FOUTL/R, FINL/R	-70	-80		dB	f = 1 kHz, sine wave, R <sub>L</sub> > 7.5 kΩ Analog Gain = 0 dB, Input = -3 dBFS or 0.5 V <sub>rms</sub> to AUXnL/R
XTALK <sub>HP</sub>	Crosstalk Left/Right Channel (Headphone)	OUTL/R	-70	-80		dB	f = 1 kHz, sine wave, OUTL/R: R <sub>L</sub> ≥ 32 Ω (47 Ω series resistor required) Analog Gain = 0 dB, Input = -3 dBFS or 0.5 V <sub>rms</sub> to AUXnL/R
XTALK <sub>2</sub>	Crosstalk between Input Signal Pairs	AUXnL/R	-70	-80		dB	f = 1 kHz, sine wave, FOUTL/R: R <sub>L</sub> > 7.5 kΩ OUTL/R: R <sub>L</sub> ≥ 32 Ω (47 Ω series resistor required) Analog Gain = 0 dB, Input = -3 dBFS and 0.5 V <sub>rms</sub> to AUXnL/R
V <sub>AGNDC</sub>	Analog Reference Voltage	AGNDC		1.5		V	SEL_53V = 0 R <sub>L</sub> >> 10 MΩ, referred to VREF
				2.25		V	SEL_53V = 1 R <sub>L</sub> >> 10 MΩ, referred to VREF

# DAC 3550A

Symbol	Parameter	Pin Name	Min.	Typ.	Max.	Unit	Test Conditions
R <sub>IAUX</sub>	Input Resistance at Input Pins	AUXnL/R	12.1 11.6	15	17.9 19.0	kΩ kΩ	T <sub>J</sub> = 27 °C T <sub>A</sub> = 0 to 70 °C <sup>1)</sup> Input selected, PWMD = 0 i = ± 10 μA, referred to VREF
			24.2 23.3	30	35.8 37.9	kΩ kΩ	T <sub>J</sub> = 27 °C T <sub>A</sub> = 0 to 70 °C <sup>1)</sup> Input not selected i = ± 10 μA, referred to VREF
R <sub>OOUT</sub>	Output Resistance at Output Pins	OUTL/R		700		Ω	T <sub>J</sub> = 27 °C PWMD = 1 i = ± 200 μA, referred to VREF
R <sub>OFLT</sub>	Output Resistance of Filter Pins	FINL		15		kΩ	PWMD = 1, Mute i = ± 10 μA, referred to VREF
		FINR		11.25		kΩ	
V <sub>OffI</sub>	Offset Voltage at Input Pins	AUXnL/R	-20		20	mV	referred to AGNDC
V <sub>OffO</sub>	Offset Voltage at Output Pins	OUTL/R	-10		10	mV	Mute referred to AGNDC
V <sub>OffFO</sub>	Offset Voltage at Filter Output Pins	FOUTL/R	-20		20	mV	PWMD = 0, referred to AGNDC
V <sub>OffFI</sub>	Offset Voltage at Filter Input Pins	FINL/R	-20		20	mV	PWMD = 0, referred to AGNDC
dV <sub>DCPD</sub>	Difference of DC Voltage at Output Pins after Back-end Low Power Sequence	OUTL/R	-10		10	mV	Analog Gain = Mute, PWMD switched from 0 to 1



4. Applications

4.1. Line Output Details

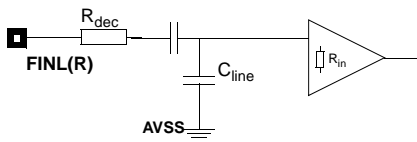

Fig. 4–1: Use of FINL/R as Line Outputs

Table 4–1: Load at FINL/R when used as Line Output for external amplifier

Filter Order	R <sub>dec</sub>	R <sub>in</sub>
1st, 2nd, 3rd	680 Ω	> 10 kΩ
R <sub>dec</sub> : Resistor used for decoupling C <sub>line</sub> from FINL(R) to achieve stability		
C <sub>line</sub> : Capacitive load according to e.g. cable, amplifier		
R <sub>in</sub> : Input resistance of amplifier		

4.2. Recommended Low-Pass Filters for Analog Outputs\*

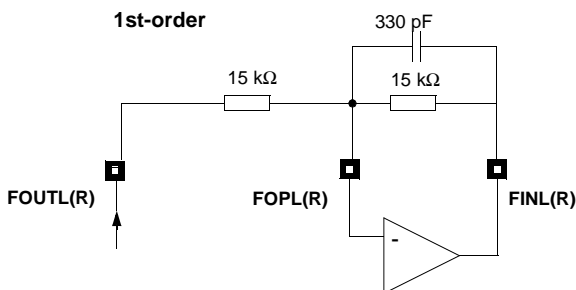

Fig. 4–2: 1st-order low-pass filter

Table 4–2: Attenuation of 1st-order low-pass filter

Frequency	Gain
24 kHz	–2.2 dB
30 kHz	–3.0 dB

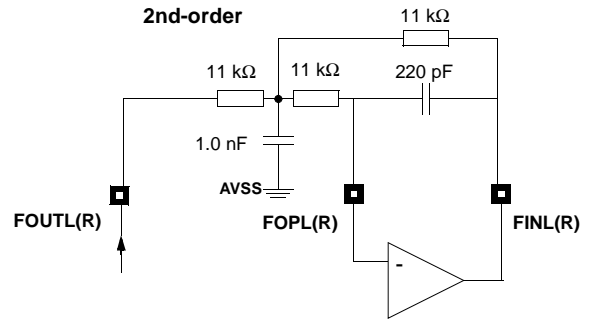

Fig. 4–3: 2nd-order low-pass filter

Table 4–3: Attenuation of 2nd-order low-pass filter

Frequency	Gain
24 kHz	–1.5 dB
30 kHz	–3.0 dB

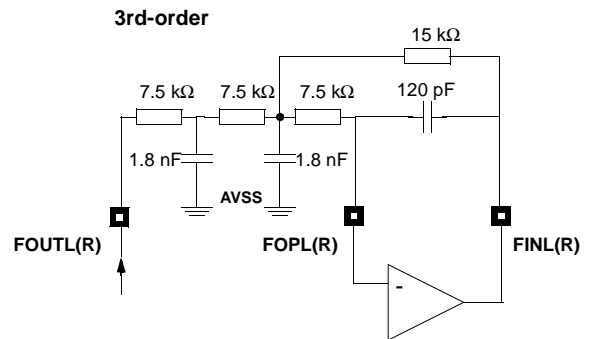

Fig. 4–4: 3rd-order low-pass filter

Table 4–4: Attenuation of 3rd-order low-pass filter

Frequency	Gain
18 kHz	0.17 dB
24 kHz	–0.23 dB
30 kHz	–3.00 dB

\* without deemphasis circuit

## 4.3. Recommendations for Filters and Deemphasis

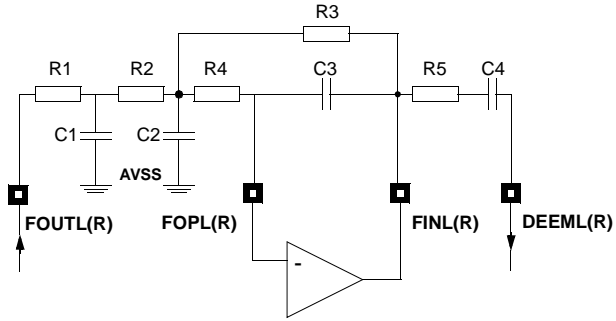

Fig. 4-5: General circuit schematic

Table 4-5: Resistor and Capacitor values

	1st order	2nd order	3rd order
R1 (k $\Omega$ )	0		7.5
C1 (pF)	open		560
R2 (k $\Omega$ )	18	11	7.5
C2 (pF)	open	1000	270
R3 (k $\Omega$ )	18	11	15
C3 (pF)	180	180	82
R4 (k $\Omega$ )	0	11	7.5
R5 (k $\Omega$ )	18	22	22
C4 (nF)	1.8	1.0	1.0

## 4.4. Recommendations for MegaBass Filter without Deemphasis plus 1st-order low-pass

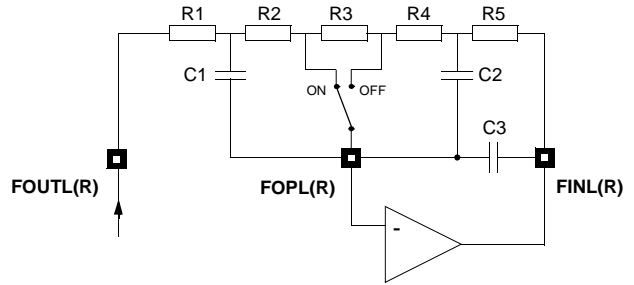

Fig. 4-6: General circuit schematic

Table 4-6: Resistor and Capacitor values

	DC-Gain = 10 dB fc1 = 100 Hz fc2 = 330 Hz
R1 (k $\Omega$ )	13
C1 (nF)	47
R2 (k $\Omega$ )	0
R3 (k $\Omega$ )	15
R4 (k $\Omega$ )	15
R5 (k $\Omega$ )	13
C2 (nF)	47
C3 (pF)	180

#### 4.5. Power-up/down Sequence

In order to get a click-free power-up/down characteristic, it is recommended to use the following sequences:

##### 4.5.1. Power-up Sequence

1. Start VDD from 0 to +3.3 V and start AVDD0/1 from 0 to +3.3 V/+5 V. AVDD should not ramp up faster than VDD.
2. Release PORQ from 0 to AVDD0/1.
3. Send I2C: volume, input select, speaker, ... optional.
4. Start I2S data.

The most important point is: PORQ has to ramp up after AVDD0/1, simply by using a 10-k $\Omega$  pull-up resistor to AVDD0/1 and a 2.2-nF capacitor to ground. No further control on PORQ is needed.

##### 4.5.2. Power-down Sequence

1. Stop I2S data.
2. Send I2C: LOW POWER.
3. Switch VDD, AVDD0/1 to 0.

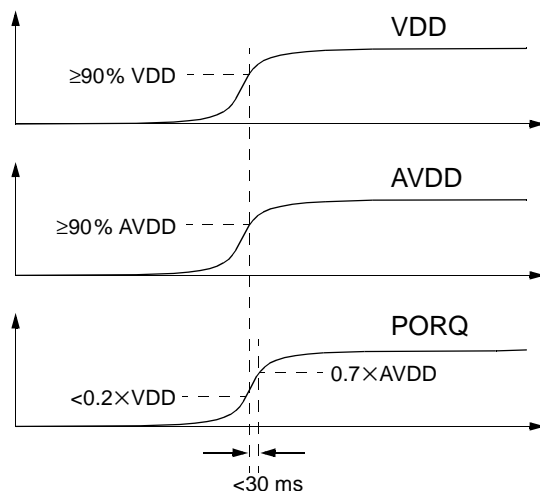

**Fig. 4–7:** Power-up sequence

4.6. Typical Applications

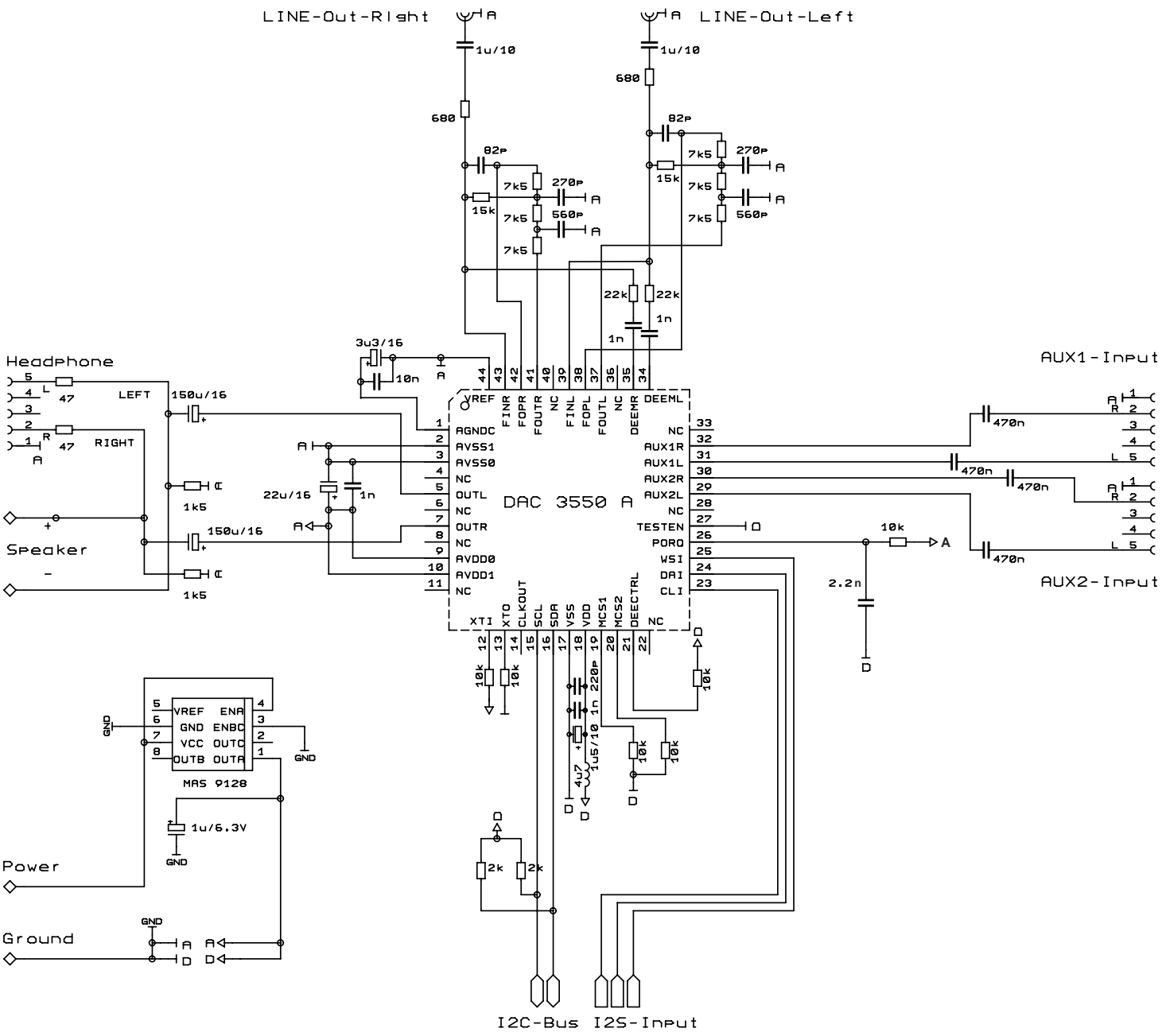

Fig. 4-8: Application circuit schematic 1: Standard application with analog deemphasis. Oscillator not needed.

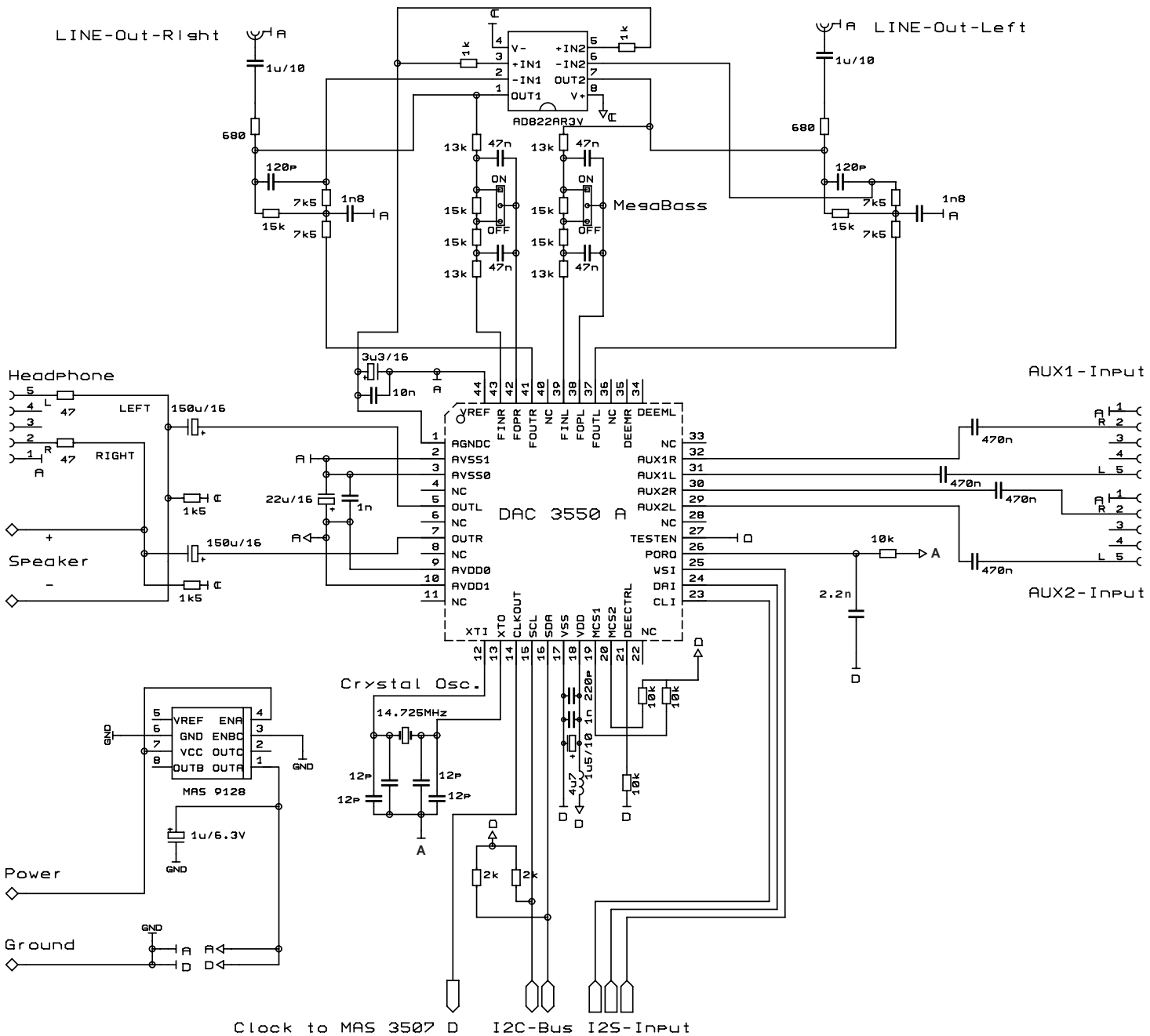
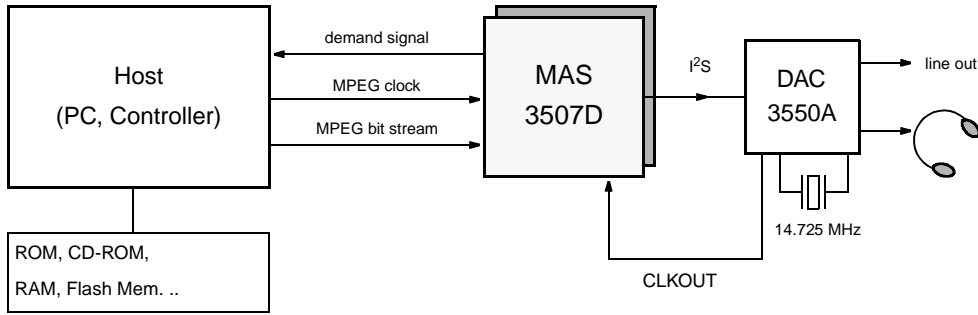
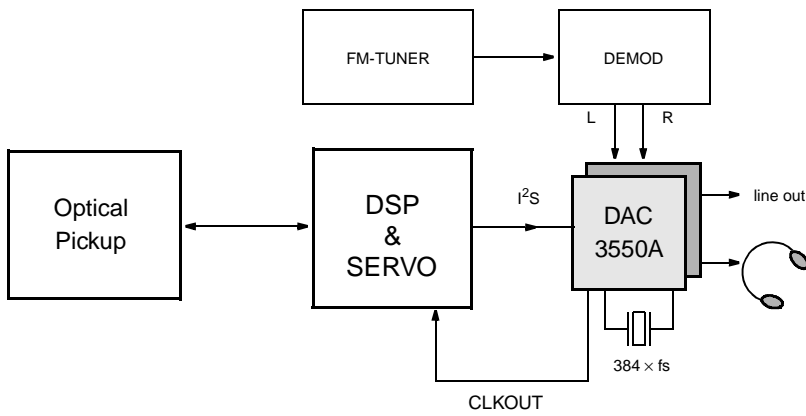

Fig. 4-9: Application circuit schematic 2: MPEG application with analog Megabass and 14.725 MHz crystal

# DAC 3550A



**Fig. 4-10: MPEG Layer-3 Player**



**Fig. 4-11: CD-Player with FM-Radio**

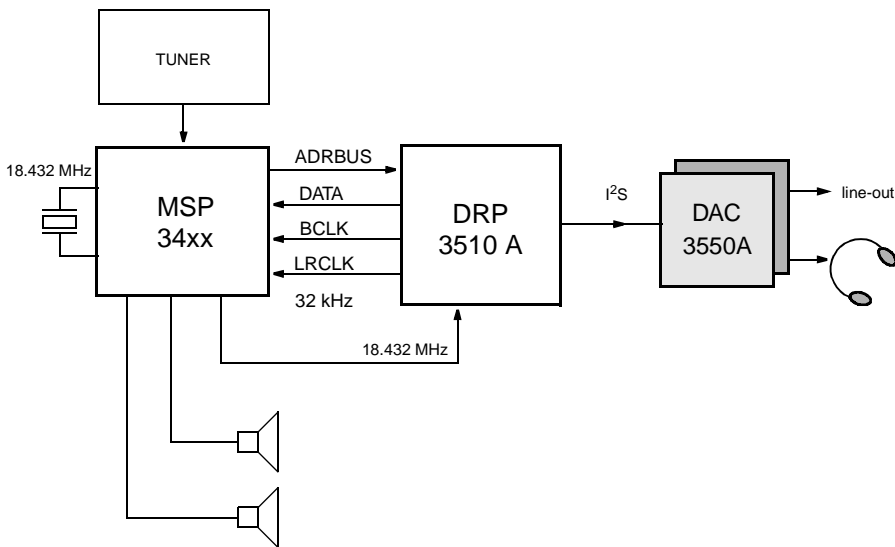

**Fig. 4-12: ADR Receiver**



## 5. Data Sheet History

1. Final data sheet: "DAC 3550A Stereo Audio DAC, Edition July 23, 1999, 6251-467-1DS. First release of the final data sheet.

Micronas GmbH  
Hans-Bunte-Strasse 19  
D-79108 Freiburg (Germany)  
P.O. Box 840  
D-79008 Freiburg (Germany)  
Tel. +49-761-517-0  
Fax +49-761-517-2174  
E-mail: [docservice@micronas.com](mailto:docservice@micronas.com)  
Internet: [www.micronas.com](http://www.micronas.com)

Printed in Germany  
Order No. 6251-467-1DS

All information and data contained in this data sheet are without any commitment, are not to be considered as an offer for conclusion of a contract, nor shall they be construed as to create any liability. Any new issue of this data sheet invalidates previous issues. Product availability and delivery are exclusively subject to our respective order confirmation form; the same applies to orders based on development samples delivered. By this publication, Micronas GmbH does not assume responsibility for patent infringements or other rights of third parties which may result from its use.

Further, Micronas GmbH reserves the right to revise this publication and to make changes to its content, at any time, without obligation to notify any person or entity of such revisions or changes.

No part of this publication may be reproduced, photocopied, stored on a retrieval system, or transmitted without the express written consent of Micronas GmbH.



Preliminary Data Sheet Supplement

<b>Subject:</b>	New Package for DAC 3550A
<b>Data Sheet Concerned:</b>	DAC 3550A 6251-467-1PD, Edition April 23, 1999
<b>Supplement:</b>	No. 2/ 6251-467-1PDS
<b>Edition:</b>	May 18, 1999

**New Package for DAC 3550A: 49-Ball Plastic Ball Grid Array (PBGA49)**

**1. Outline Dimensions**

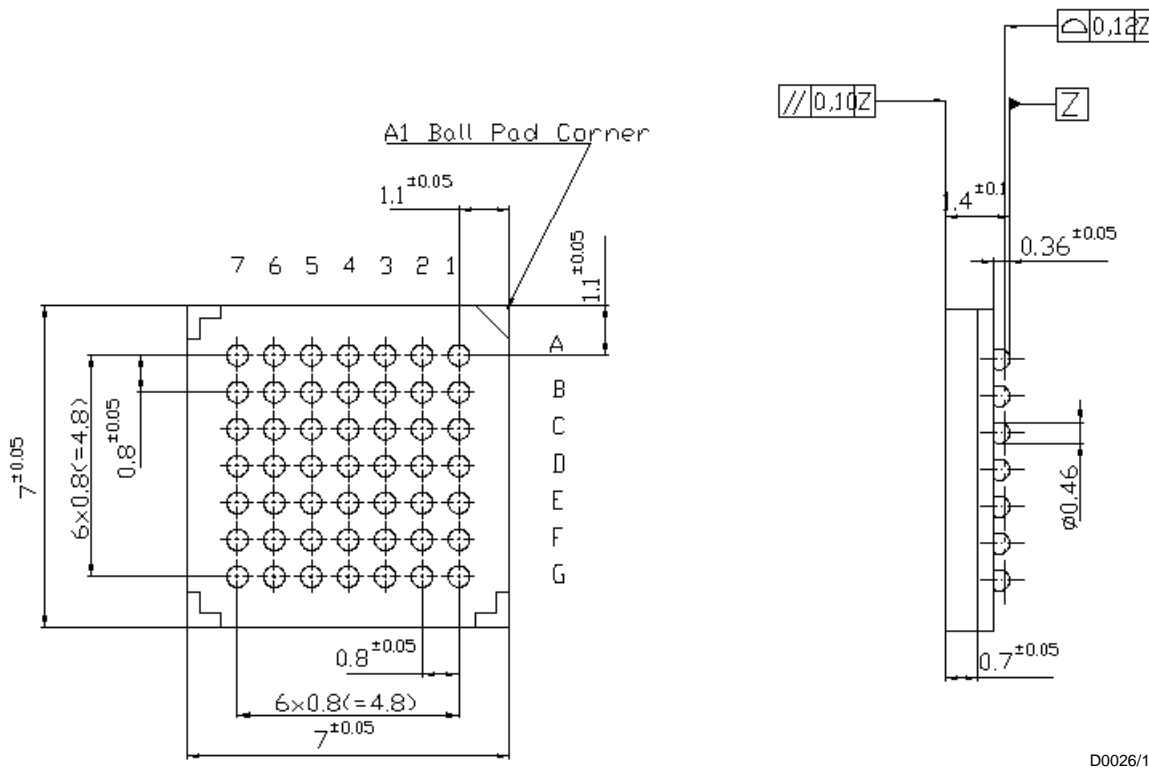

D0026/1E

**Fig. 1:**  
49-Ball Plastic Ball Grid Array  
**(PBGA49)**  
Dimensions in mm

**2. Pin Connections and Short Descriptions**

NC = not connected, leave vacant  
 X = obligatory; connect as described  
 in application circuit diagram

LV = if not used, leave vacant  
 VSS = if not used, connect to VSS  
 VDD = connect to VDD

Unassigned pins must be left vacant.

Pin No. / Pin ID	Pin Name	Type	Connection (If not used)	Short Description	
					PMQFP 44-pin
1	B5	AGNDC	BID	X	Analog reference voltage
2	A6	AVSS1	SUPPLY	X	VSS 1 for audio back-end
3	B4	AVSS0	SUPPLY	X	VSS 0 for audio output amplifiers
4		NC		LV	Not connected
5	C4	OUTL	OUT	LV	Audio output: headphone left or speaker +
6		NC		LV	Not connected
7	A3	OUTR	OUT	LV	Audio output: headphone right or Speaker –
8		NC		LV	Not connected
9	A2	AVDD0	SUPPLY	X	VDD 0 for audio output amplifiers
10	A1	AVDD1	SUPPLY	X	VDD 1 for audio back-end
11		NC		LV	Not connected
12	C3	XTI	IN	X	Quartz oscillator pin 1
13	C2	XTO	BID	X	Quartz oscillator pin 2
14	D2	CLKOUT	OUT	LV	Clock output
15	C1	SCL	BID	LV	I <sup>2</sup> C clock
16	D3	SDA	BID	LV	I <sup>2</sup> C data
17	D1	VSS	SUPPLY	X	Digital VSS
18	E1	VDD	SUPPLY	X	Digital VDD
19	F2	MCS1	IN	X	I <sup>2</sup> C chip sSelect 1
20	F1	MCS2	IN	X	I <sup>2</sup> C chip select 2
21	G1	DEECTRL	IN	VSS	Deemphasis on/off control
22		NC		LV	Not connected
23	E3	CLI		VSS	I <sup>2</sup> S bit clock
24	F3	DAI	IN	VSS	I <sup>2</sup> S data
25	F4	WSI	IN	VSS	I <sup>2</sup> S frame identification
26	G4	PORQ	IN	VDD	Power-on-reset, active-low

Pin No. / Pin ID		Pin Name	Type	Connection (If not used)	Short Description
PMQFP 44-pin	PBGA 49-ball				
27	F5	TESTEN	IN	X	Test enable
28		NC		LV	Not connected
29	G5	AUX2L	IN	LV	AUX2 left input for external analog signals (e.g. tape)
30	F6	AUX2R	IN	LV	AUX2 right input for external analog signals (e.g. tape)
31	G6	AUX1L	IN	LV	AUX1 left input for external analog signals (e.g. FM)
32	G7	AUX1R	IN	LV	AUX1 right input for external analog signals (e.g. FM)
33		NC		LV	Not connected
34	E5	DEEML	OUT	LV	Deemphasis network, left
35	E6	DEEMR	OUT	LV	Deemphasis network, right
36		NC		LV	Not connected
37	F7	FOUTL	OUT	X	Output to left external filter
38	D6	FOPL	BID	X	Filter op amp inverting input, left
39	E7	FINL	IN/OUT	X	Input for FOURL or filter op amp output (line out)
40		NC		LV	Not connected
41	D7	FOUTR	OUT	X	Output to right external filter
42	C6	FOPR	BID	X	Right filter op amp inverting input
43	C7	FINR	IN/OUT	X	Input for FOUTR or filter op amp output (line out)
44	A7	VREF	IN	X	Analog reference ground