

TOSHIBA Bi-CMOS INTEGRATED CIRCUIT SILICON MONOLITHIC

T B 2 1 1 8 F

HIGH SPEED PLL FOR DTS

TB2118F is a high-speed phase-locked loop (PLL) LSI for car audio tuners with a built-in charge pump circuit. All functions are controlled through serial bus lines. The device is used to configure high-performance digital tuning systems.

FEATURES

- Built-in high-speed program divider with built-in prescalers.
 - FM : 30~150 MHz (Pulse swallowing method)
 - AM : 1~40 MHz (Pulse swallowing method)
- Phase comparator outputs are constant current output for both FM and AM. Current values can be switched using serial data. In high-speed mode for large current output seek, the lockup time between FM band edges can be set to approx. 500 μ s by selecting an appropriate VT range and low-pass filter constant.
- RDS supported
N-value data and charge pump output current data (total of 18-bits) can be selected using two registers.
- Built-in low-pass filter op-amps for FM and AM.
- Built-in 20-bit binary counter for counting IF frequency.
- Crystal oscillator can be used 10.25 MHz or 10.35 MHz.
- Two output ports (open-collector output) and two I/O ports (CMOS) supported.
- Package is SSOP 24 pin.

(Note) Pins 1 and 24 are susceptible to surge. Take care when handling.

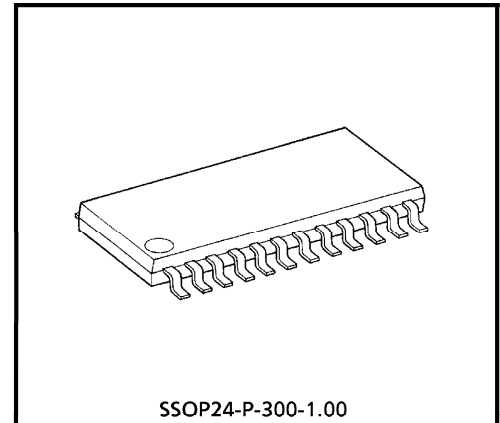

SSOP24-P-300-1.00

Weight : 0.31 g (Typ.)

980910EBA1

- TOSHIBA is continually working to improve the quality and the reliability of its products. Nevertheless, semiconductor devices in general can malfunction or fail due to their inherent electrical sensitivity and vulnerability to physical stress. It is the responsibility of the buyer, when utilizing TOSHIBA products, to observe standards of safety, and to avoid situations in which a malfunction or failure of a TOSHIBA product could cause loss of human life, bodily injury or damage to property. In developing your designs, please ensure that TOSHIBA products are used within specified operating ranges as set forth in the most recent products specifications. Also, please keep in mind the precautions and conditions set forth in the TOSHIBA Semiconductor Reliability Handbook.
- The products described in this document are subject to the foreign exchange and foreign trade laws.
- The information contained herein is presented only as a guide for the applications of our products. No responsibility is assumed by TOSHIBA CORPORATION for any infringements of intellectual property or other rights of the third parties which may result from its use. No license is granted by implication or otherwise under any intellectual property or other rights of TOSHIBA CORPORATION or others.
- The information contained herein is subject to change without notice.

PIN CONNECTION

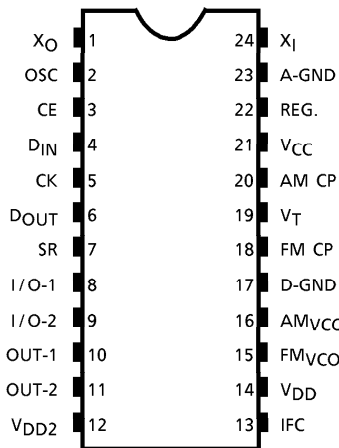

BLOCK DIAGRAM

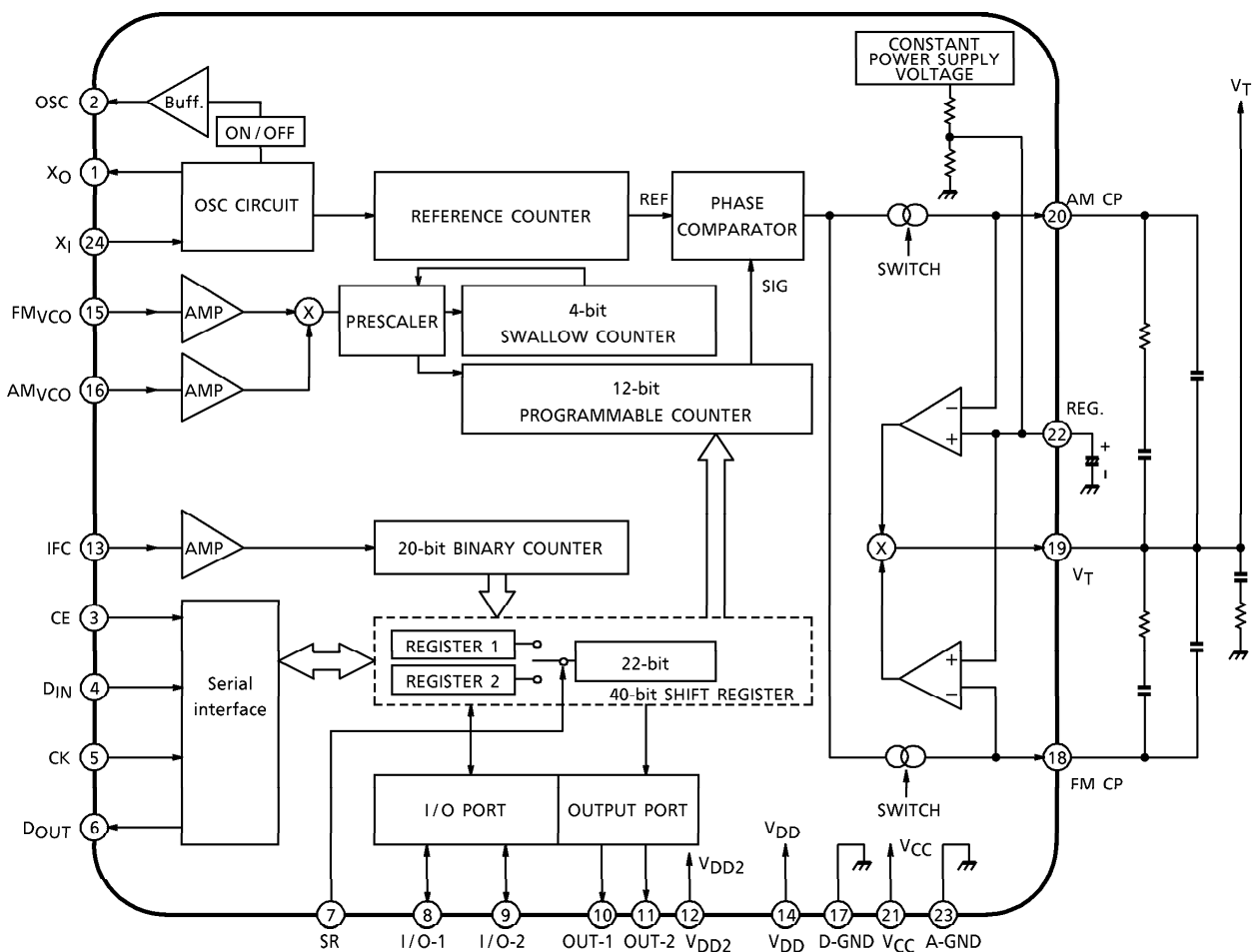

PIN FUNCTION

PIN NO.	SYMBOL	PIN NAME	FUNCTION AND OPERATION	REMARKS
1	X _O	Crystal Oscillator Pins	<ul style="list-style-type: none"> Serial data input : Setting F0 and F1 bits selects the frequency of the crystal oscillator to be connected. 	
24	X _I			
2	OSC	Crystal Oscillator Output Pin	<ul style="list-style-type: none"> Setting the OSC bit outputs the oscillation frequency. 0 = output OFF 1 = output ON 	—
15	FM _{VCO}	FM Band Local Signal Input	<ul style="list-style-type: none"> Serial data input : When AM/FM bit = "0" FM_{VCO} is selected. Input signal is directly transferred to the swallow counter. Input frequency : 30 to 150 MHz Divided frequency : 528 to 65.535 	
16	AM _{VCO}	AM Band Local Signal Input	<ul style="list-style-type: none"> Serial data input : When AM/FM bit = "1" AM_{VCO} is selected. When MODE = "1" AM band is selected (by pulse swallow). Input frequency : 1.0 to 40 MHz Divided frequency : 528 to 65.535 	
13	IFC	IF Signal Input	<ul style="list-style-type: none"> Input frequency : 0.1 to 15 MHz The selected signal is input to a 20-bit general-purpose counter via a gate circuit. 	
3	CE	Chip Enable Input	<p>Serial interface pins.</p> <ul style="list-style-type: none"> Data used for controlling TB2118F are exchanged between controllers. Control data are input via D_{IN} in sync. with clock input via CK. Control data input start/stop is specified using CE. General-purpose counter data are output in sync. with clock input via CK from D_{OUT}. The CK/CE/D_{IN} pin is Schmitt trigger input. 	
5	CK	Clock Input		
4	D _{IN}	Serial Data Input		
6	D _{OUT}	Serial Data Output		

PIN FUNCTION

PIN NO.	SYMBOL	PIN NAME	FUNCTION AND OPERATION	REMARKS
7	SR	Register Control Pin.	<ul style="list-style-type: none"> • Selects register 1 or 2. • "L" = register 1 output • "H" = register 2 output 	—
8	I/O-1	I/O Ports	<ul style="list-style-type: none"> • Input or output is switched in units of bits by serial data input. • CMOS input/CMOS output • At power on, set to input ports. 	
9	I/O-2			
10	OUT-1	Output Ports	<ul style="list-style-type: none"> • Open collector output ports. 	
11	OUT-2			
12	VDD2		<ul style="list-style-type: none"> • Single power supply for reference frequency block • VDD2 = 3.0 to 5.5 V (note that VDD ≥ VDD2) • Due to the crystal high-frequency receive interference characteristic, we recommend an RD setting so that VDD2 = 3.5 V. 	
14	VDD	CMOS Power Pins	<ul style="list-style-type: none"> • Power pins for digital block (digital circuits). • VDD = 4.5 to 5.5 V, D-GND = 0 V 	—
17	D-GND			
21	VCC	Bipolar Power Pins	<ul style="list-style-type: none"> • Power pins for analog block (eg, op-amps, constant-voltage supply) • VCC = 8 to 10 V, A-GND = 0 V 	—
23	A-GND			
22	REG.	Ripple Filter Connecting Pin.	Ripple filter connecting pin for internal constant voltage supply. Insert about 10μF (as high as possible) between this pin and A-GND.	—
19	V _T	Tuning Voltage	<ul style="list-style-type: none"> • Input from the plus terminal of the op-amp is internally biased to 2.5 V. • External crystal for phase correction is required because low gain is set by high through rate. 	

PIN FUNCTION

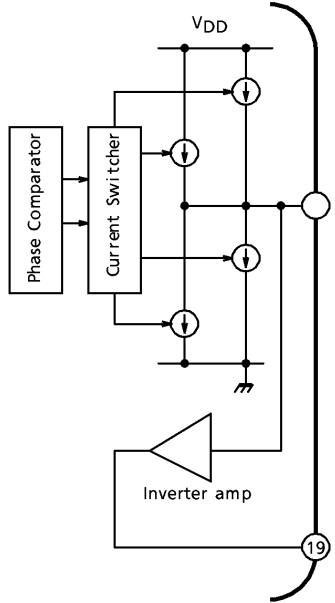
PIN NO.	SYMBOL	PIN NAME	FUNCTION AND OPERATION	REMARKS
20	AM CP	AM Charge Pump Output	<p>Charge pump output for AM</p> <ul style="list-style-type: none"> Serial data input : When AM / FM = "1" error output from the phase comparator is output as constant current. $f_{REF} > f_{SIG}$: \ominus current output $f_{REF} = f_{SIG}$: high impedance $f_{REF} < f_{SIG}$: \oplus current output Serial data : Output current can be switched using CR0 and CR1 bits. Normally (when using AM op-amp), set the OP SEL bit to "1". 	
18	FM CP	FM Charge Pump Output	<p>Charge pump output for FM</p> <ul style="list-style-type: none"> Serial data input : When AM / FM = "0" error output from the phase comparator is output as constant current. $f_{REF} > f_{SIG}$: \ominus current output $f_{REF} = f_{SIG}$: high impedance $f_{REF} < f_{SIG}$: \oplus current output Serial data : Output current can be switched using CR0 and CR1 bits. Normally (when using FM op-amp), set the OP SEL bit to "0". 	

OPERATION

1. Configuration of Control Data (Serial data input/output)

1) Data input mode (Valid data length changes according to the address.)

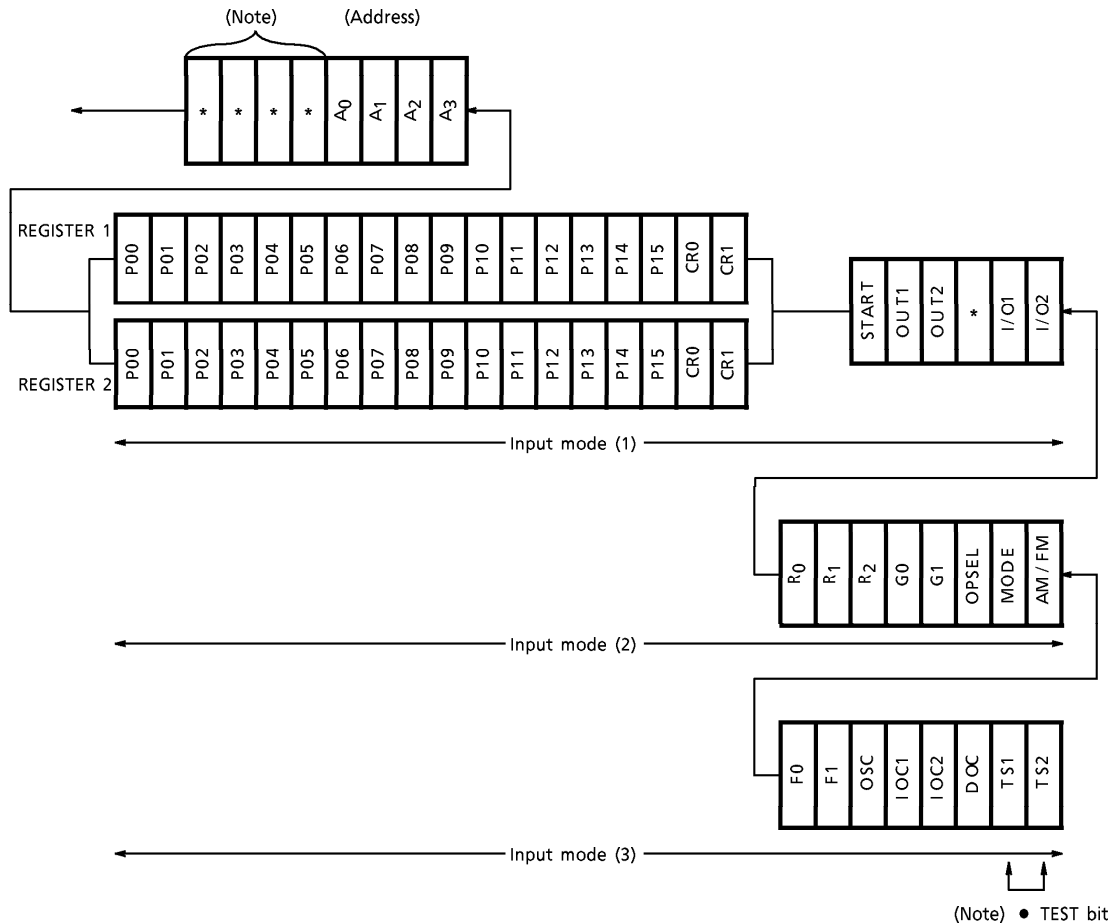

A ₀	A ₁	A ₂	A ₃	INPUT MODE	VALID DATA LENGTH	REMARKS
0	#	0	1	(1)	24 bits	Processes frequency change.
0	#	1	0	(2)	32 bits	Processes band change.
0	#	1	1	(3)	40 bits	Processes power on (initialization).

When "0" is set in bits marked with #, data are loaded to register 1; when "1" is set, to register 2.

- (Note)
- Either "0" or "1" can be set in bits marked with *.
 - TS1 and TS2 are pins for internal testing. At power on, be sure to clear to "0" (data set).

2) Data output mode

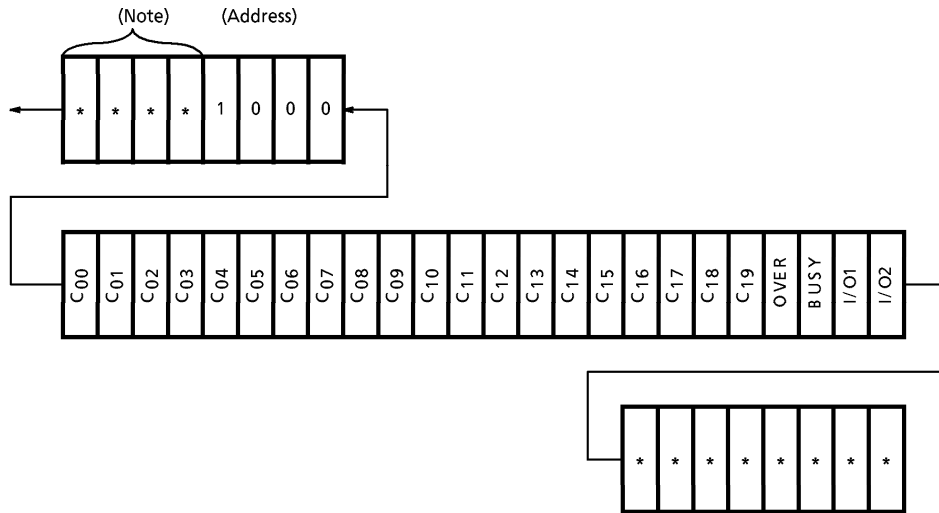

(Note) Either "0" or "1" can be set in bits marked with *.

3) Serial data transfer formats

- Data input mode (At input, D_{OUT} becomes high impedance.)

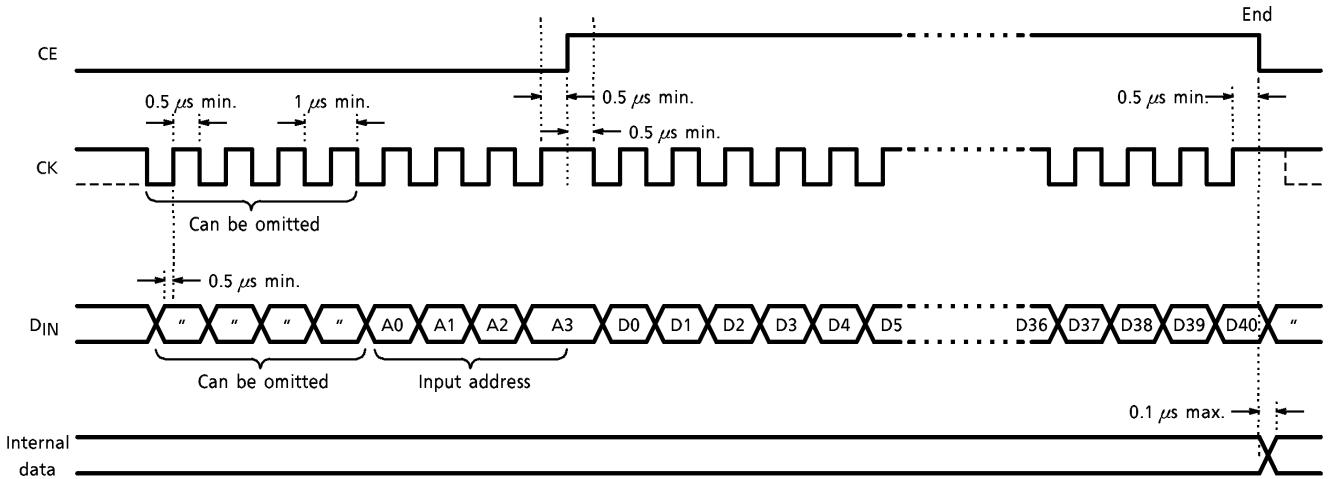

(Note) • When power for TB2118F is fully on, input data after 100 ms or more.

- Until data input starts, set the CE pin to GND to avoid any noise input.

- Data output mode

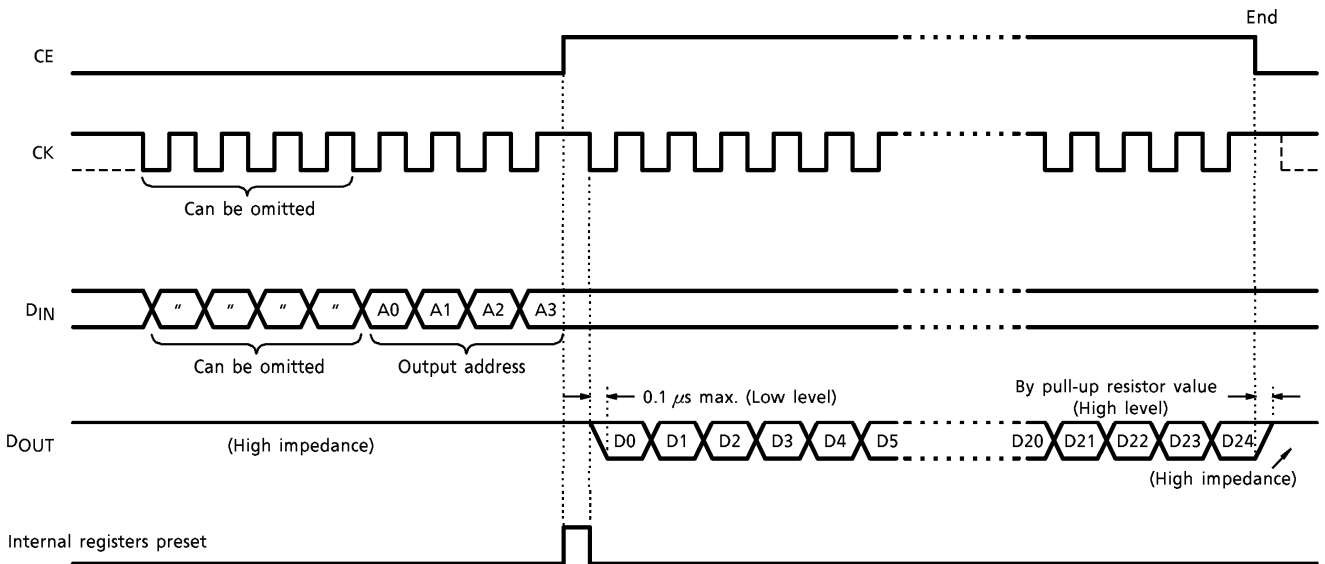

(Note) • Normally, D_{OUT} is high impedance.

- During data output, data output mode is terminated by changing CE = H to L.

2. Setting Reference Frequency-Related (reference divider block) Items

1) Setting crystal oscillator (OSC)

With TB2118F, the two-frequency oscillator shown below can be driven by self-oscillation.

F0 BIT	F1 BIT	INPUT FREQUENCY
0	0	10.25 MHz
0	1	10.35 MHz

(Note) At power on, F0 / F1 = 0.

● Connection example

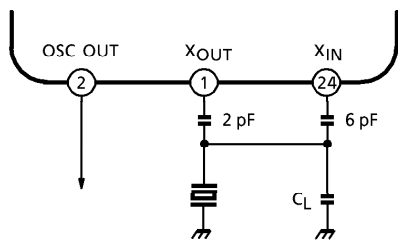

(Note) Use a crystal oscillator with $R_S = 50 \Omega$ and less and $C_L = 12 \text{ pF}$ or less.

2) Setting reference frequency (R_0, R_1, R_2)

R_0	R_1	R_2	10.25 MHz	10.35 MHz
0	0	0	—	—
1	0	0	50 kHz	50 kHz
0	1	0	—	—
1	1	0	—	—
0	0	1	10 kHz	—
1	0	1	—	9 kHz
0	1	1	—	—
1	1	1	1 kHz	—

(Note) Do not select settings where — is entered instead of frequency.

3) OSC output select (OSC) = oscillation frequency is output from the OSC OUT pin.

OSC	OSC OUT PIN
0	Output OFF
1	Output ON

(Note) At power ON, OSC = 0.

3. Setting Programmable Counter Block

1) Circuit configuration

The programmable counter block consists of a 2-modulus prescaler, 4-bit swallow counter, and 12-bit programmable binary counter.

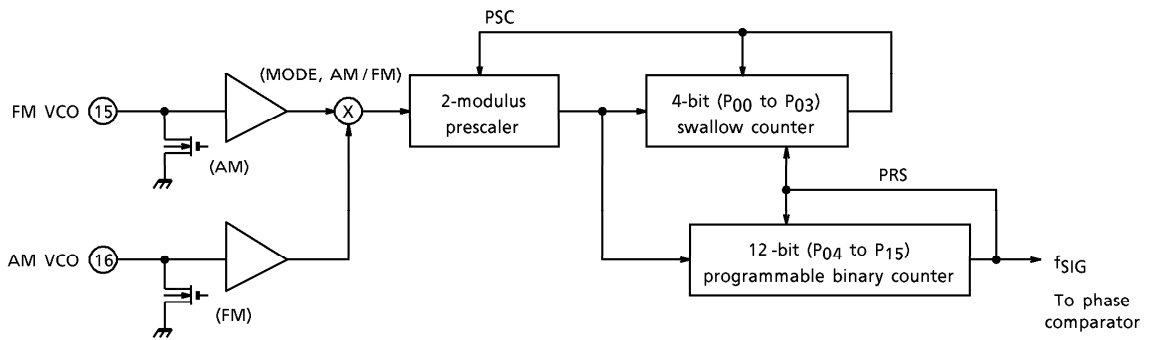

2) Setting input pin/dividing mode (AM / FM, MODE)

AM / FM	MODE	INPUT PIN	INPUT FREQUENCY	DIVIDED FREQUENCY	DIVIDING MODE
0	0	FM _{VCO}	30~150 MHz	528~65.535	By pulse swallow (16-bit)
1	1	AM _{VCO}	1~40 MHz		

3) Setting divided frequency (P₀₀ to P₁₅)

- By pulse swallow (in FW or SW mode), n = 528 to 65.535

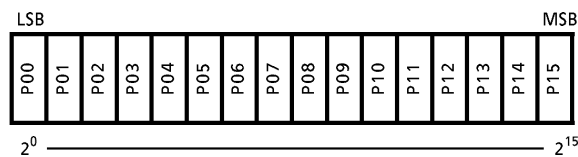

4. Control of Phase Comparator and Charge Pumps

The phase comparator compares the phase difference between the reference frequency signal (f_{REF}) and the programmable counter divisor output (f_{SIG}) and outputs the result. The constant current driver block outputs phase error signals as a current.

1) Setting charge pumps and op-amps (OPSEL)

The OPSEL bit is used to select a charge pump and an op-amp.

OPSEL	CHARGE PUMP (CP) OUTPUT	OP-AMP	AM CP OUTPUT	FM CP OUTPUT
0	DOFM	FM amp	Hz	DO
1	DOAM	AM amp	DO	Hz

Hz = high impedance
DO = tri-state output

2) Setting current value (CRO)

- AM / FM = "1" (AM_{IN} input)

CR1	CR0	AM CP OUT output current
0	0	± 0.3 mA
0	1	± 0.5 mA

- AM / FM = "0" (FM_{IN} input)

CR1	CR0	FM CP OUT output current
0	0	± 250 μ A
1	0	± 5 mA

3) Connection example (The filter circuit is an example for reference. Check and design depending on the desired characteristics for your set.)

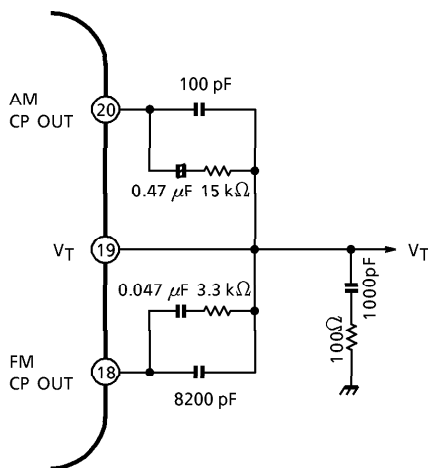

5. Control of General-Purpose Counter Circuit

The general-purpose counter is a 20-bit counter used to measure the intermediate frequency. This is used at auto tuning for detecting a radio station. Setting "1" in the START bit starts counting after counter reset.

1) Circuit configuration

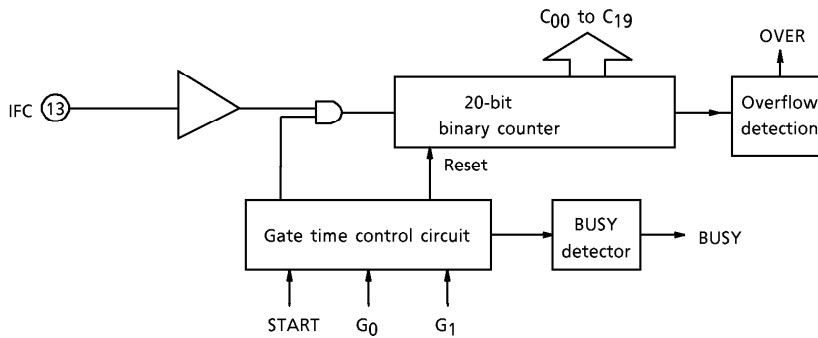

2) Setting IF counter gate time / wait time (G₀, G₁)

G ₀	G ₁	GATE TIME	WAIT TIME
0	0	1 ms	3.3~4.3 ms
1	0	4 ms	
0	1	16 ms	7.3~8.3 ms
1	1	64 ms	

3) Counter output data (C₀₀ to C₁₉)

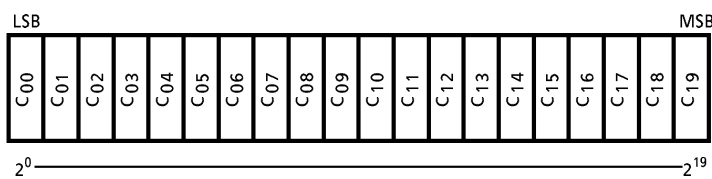

4) Detecting counter operating status

BUSY	COUNTER OPERATING STATUS
0	Counting ended
1	Counting

OVER	COUNTER VALUE
0	$N \leq 2^{20} - 1$
1	$N \geq 2^{20}$ (overflow)

(*) Setting the DOC bit to "1" enables constant output of BUSY state from the D_{OUT} pin.
 Note that at this time, the BUSY status is the inversion of the BUSY bit : BUSY status = 0 (counting) and BUSY status = 1 (counting ended).
 The DOC bit is set to "0" at power on.

5) Counter timing (when PLL data are updated and counting starts)

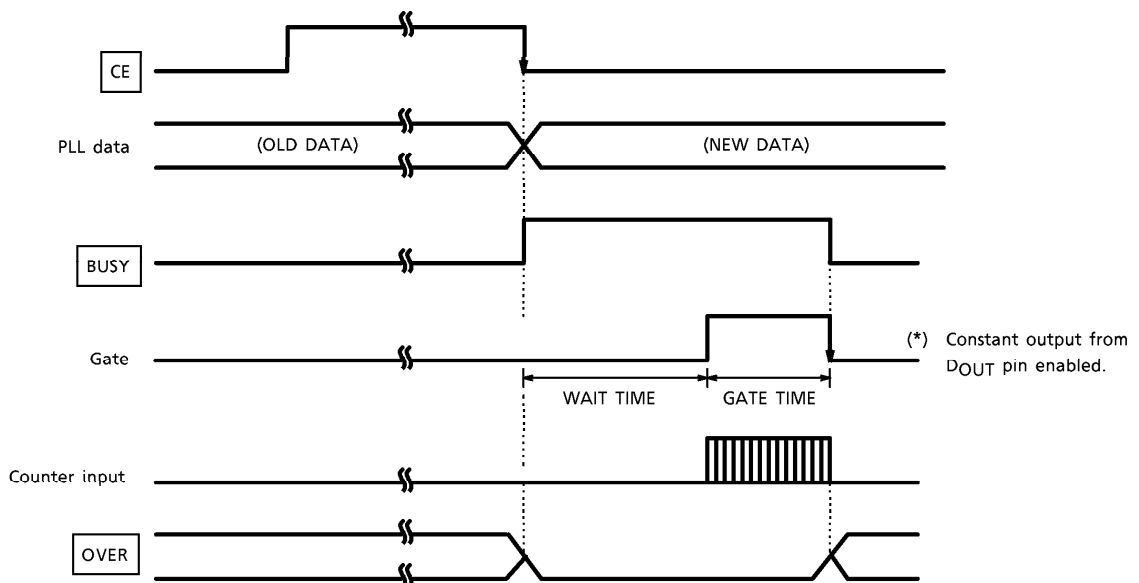

6. Setting General-Purpose I/O Ports

1) Setting output ports (OUT-1, OUT-2)

OUT1, 2	OUTPUT PORT STATUS
0	Driver off (high impedance)
1	Driver on (Low level)

2) Setting I/O control and I/O output ports (I/O1, I/O2, I/OC1, IOC2)

IOC1, 2	I/O PORT SETTING
0	Input port (CMOS input)
1	Output port (CMOS output)

I/O1, 2	OUTPUT PORT STATUS
0	Low-level output
1	High-level output

(Note) Valid only when set to output port.

- At power on, I/O ports are set to input.

3) Reading I/O port data (I/O1, I/O2 : output mode data)

I/O1, 2	INPUT PORT STATUS
0	Low-level input
1	High-level input

(Note) Valid only when set to input port.

7. Others

1) Control (DOC) of serial data output (D_{OUT})

DOC	D _{OUT} OUTPUT STATUS	REMARKS
0	Other than in output mode, high impedance.	—
1	Outputs BUSY status of general-purpose counter (constant output mode).	0 : Counting 1 : Counting ended

- At power on, DOC = 0.

MAXIMUM RATINGS (Ta = 25°C)

CHARACTERISTICS	SYMBOL	RATING	UNIT
Power Supply Voltage (1)	V _{DD}	-0.3~6.0	V
Power Supply Voltage (2)	V _{CC}	-0.3~11.0	V
V _{DD} Input Voltage	V _{IN} (1)	-0.3~V _{DD} + 0.3	V
V _{CC} Input Voltage	V _{IN} (2)	-0.3~V _{CC} + 0.3	V
Applied Voltage On Pins ⑥, ⑩, ⑪	V _{CEO}	12	V
Power Dissipation	P _D	430	mW
Operating Temperature	T _{opr}	-40~85	°C
Storage Temperature	T _{stg}	-65~150	°C

ELECTRICAL CHARACTERISTICS (unless otherwise specified, Ta = 25°C, V_{CC} = 8.5 V, V_{DD} = 5 V, V_{DD2} = 3.5 V, V_{SS} = GND = 0 V)

SUPPLY VOLTAGE AND CURRENT (V_{CC}, V_{DD}, V_{DD2}, A-GND, D-GND)

CHARACTERISTICS	SYMBOL	TEST CIRCUIT	TEST CONDITION	MIN.	TYP.	MAX.	UNIT	
Operating Power Supply Voltage	V _{CC}	—	Ta = -40~85°C	8.0	8.5	10.0	V	
	V _{DD}			4.5	5.0	5.5		
	V _{DD2}			3.0	3.5	5.5		
Operating Power Supply Current	I _{CC}	—	f _{XT} = 10.25 MHz Ta = 25°C FM _{IN} = 150 MHz	—	17.0	25.0	mA	
	I _{DD}			V _{CC} = 10 V max.	—	20.0		29.0
	I _{DD2}			V _{DD} = 5.5 V max. V _{DD2} = 5.5 V max.	—	0.25		1.0

CRYSTAL OSCILLATOR CIRCUIT (X_{TIN}, X_{TOUT})

Crystal Oscillator Frequency	f _{XT}	—	Connect the crystal oscillator to X _{TIN} and X _{TOUT} .	—	10.25	10.35	MHz
Oscillator Output Level	OSCO	1	OSC pin	100	560	—	mV _{rms}

TEST CIRCUIT 1

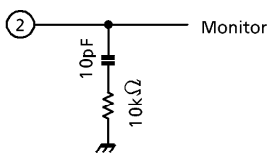

OPERATING FREQUENCY RANGE (FM_{IN}, AM_{IN}, AM / FM IF)

CHARACTERISTICS	SYMBOL	TEST CIR-CUIT	TEST CONDITION	MIN.	TYP.	MAX.	UNIT
FM _{VCO} Operating Frequency	f _{FM}	—	V _{IN} = 0.2 V _{p-p} , sine wave input, capacitive coupling, by pulse swallow	30	~	150	MHz
AM _{VCO} Operating Frequency	f _{AM}	—	V _{IN} = 0.2 V _{p-p} , sine wave input, capacitive coupling, by pulse swallow	1.0	~	40	MHz
IFC Operating Frequency	f _{IF}	—	V _{IN} = 0.2 V _{p-p} , sine wave input, capacitive coupling, IFC pin	0.1	~	15	MHz

INPUT RANGE (FM_{VCO}, AM_{VCO}, IFC)

IFC Input Level	IFC V _{IN}	—	Input Frequency 0.1~15 MHz	0.2	~	V _{DD} - 0.5	V _{p-p}
FM _{VCO} Input Level	FM _{VCO} V _{IN}	—	Input Frequency 30~120 MHz(*)	0.141	~	V _{DD} - 0.5	V _{p-p}
			Input Frequency 120~150 MHz	0.2	~	V _{DD} - 0.5	
AM _{VCO} Input Level	AM _{VCO} V _{IN}	—	Input Frequency 1.0~15 MHz (*)	0.113	~	V _{DD} - 0.5	V _{p-p}
			Input Frequency 15~40 MHz	0.2	~	V _{DD} - 0.5	

(*) Weekly code 9843~.

SERIAL INTERFACE (CE, CK, D_{IN}, D_{OUT}, SR)

Input Voltage	High Level	V _{IH} (1)	—	CE, CK, D _{IN} , SR pins	V _{DD} - 1.5	~	V _{DD}	V	
	Low Level	V _{IL} (1)			0	~	1.5		
Input Current	High Level	I _{IH} (1)	—		V _{IH} = 5 V	—	+ 1.0	μA	
	Low Level	I _{IL} (1)			V _{IL} = 0 V	—	+ 1.0		
Low-level Output Current		I _{OL} (1)	—	D _{OUT} pin	V _{OL} = 0.2 V	0.8	3.0	—	mA
Output Off-leak Current		I _{OFF} (1)	—		V _{OH} = 5 V	- 1.0	—	+ 1.0	μA

OUTPUT PORTS (OUT-1, OUT-2)

Low-level Output Current	I _{OL} (2)	—	V _{OL} = 0.2 V	0.8	3.0	—	mA
Output Off-leak Current	I _{OFF} (2)	—	V _{OH} = 10 V	- 1.0	—	+ 1.0	μA

I/O PORTS (I/O-1, I/O-2)

Input Current	High Level	I_{IH} (2)	—	$V_{IH} = 5\text{ V}$	- 1.0	—	+ 1.0	μA
	Low Level	I_{IL} (2)		$V_{IL} = 0\text{ V}$	- 1.0	—	+ 1.0	
Input Voltage	High Level	V_{IH} (2)	—		$V_{DD} - 1.5$	~	V_{DD}	V
	Low Level	V_{IL} (2)			0	~	1.5	
Output Current	High Level	I_{OH} (1)	—	$V_{OH} = 4.0\text{ V}$	- 5.0	- 7.5	—	mA
	Low Level	I_{OL} (3)		$V_{OL} = 1.0\text{ V}$	3.5	4.5	—	

CHARGE PUMPS (AMCPOUT, FMCP OUT)

CHARACTERISTICS	SYMBOL	TEST CIRCUIT	TEST CONDITION	TEST CONDITION		MIN.	TYP.	MAX.	UNIT
				CR0 BIT	CR1 BIT				
FM Charge Pump Output Current	I_{OFM} (1)	—	DOFM pin	0	0	± 0.20	± 0.25	± 0.4	mA
	I_{OFM} (2)			0	1	± 4.0	± 5.0	± 7.0	
AM Charge Pump Output Current	I_{OAM} (1)	—	DOAM pin	0	0	± 0.2	± 0.3	± 0.45	mA
	I_{OAM} (2)			1	0	± 0.4	± 0.5	± 0.75	

OP-AMPS (V_T)

AM Op-amp Output Current	I_{OL}	—	$V_{IN} = V_{DD}, V_{OUT} = 8.5\text{ V}$	1.0	2.0	—	mA
	I_{OH}		$V_{IN} = GND, V_{OUT} = 0\text{ V}$	- 1.0	- 2.0	—	
FM Op-amp Output Current	I_{OL}	—	$V_{IN} = V_{DD}, V_{OUT} = 8.5\text{ V}$	5.0	9.0	—	mA
	I_{OH}		$V_{IN} = GND, V_{OUT} = 0\text{ V}$	- 5.0	- 9.0	—	
V_T Output Voltage	V_T	—		0.3	~	$V_{CC} - 1.1$	V

APPLICATION CIRCUIT 1

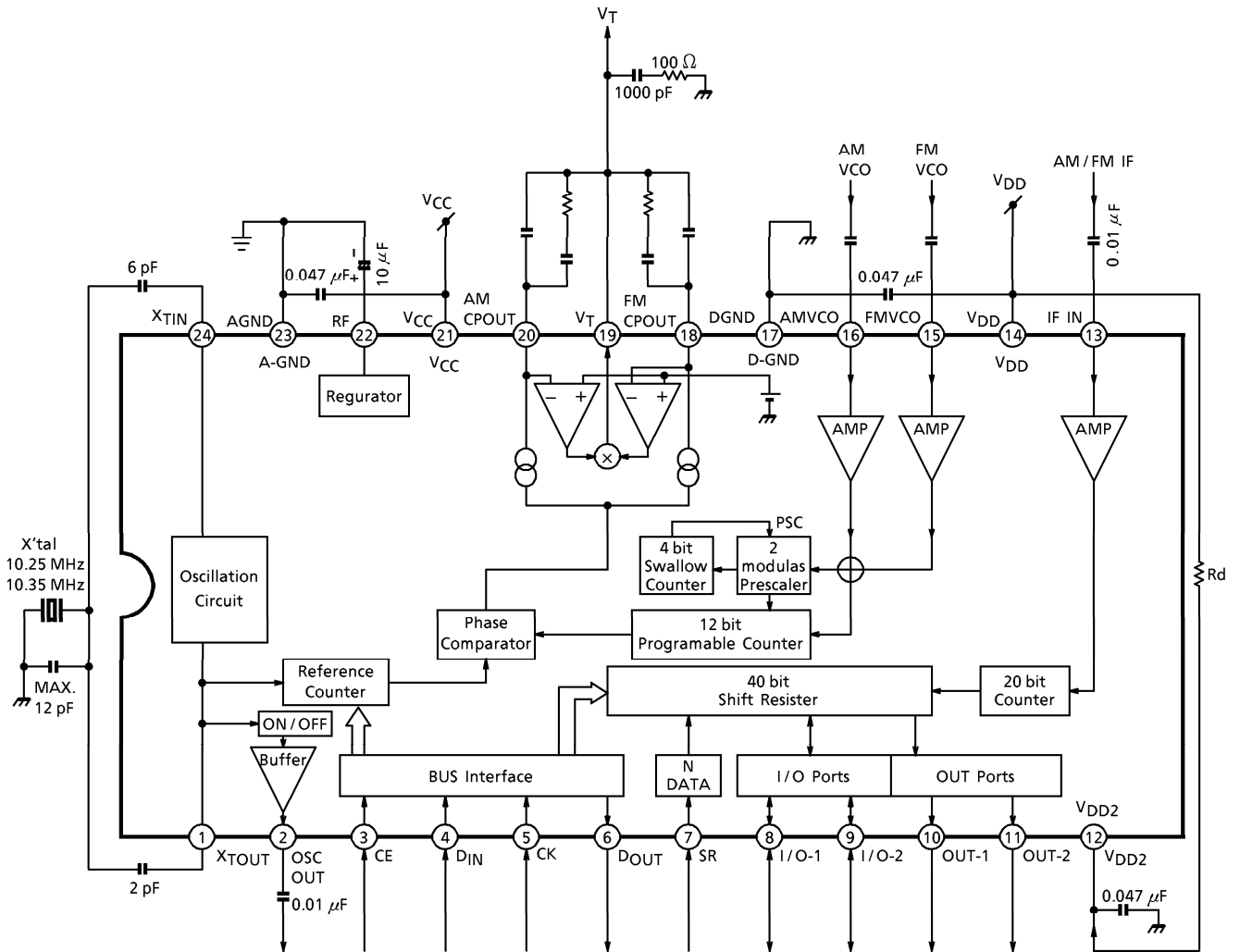

OUTLINE DRAWING
SSOP24-P-300-1.00

Unit : mm

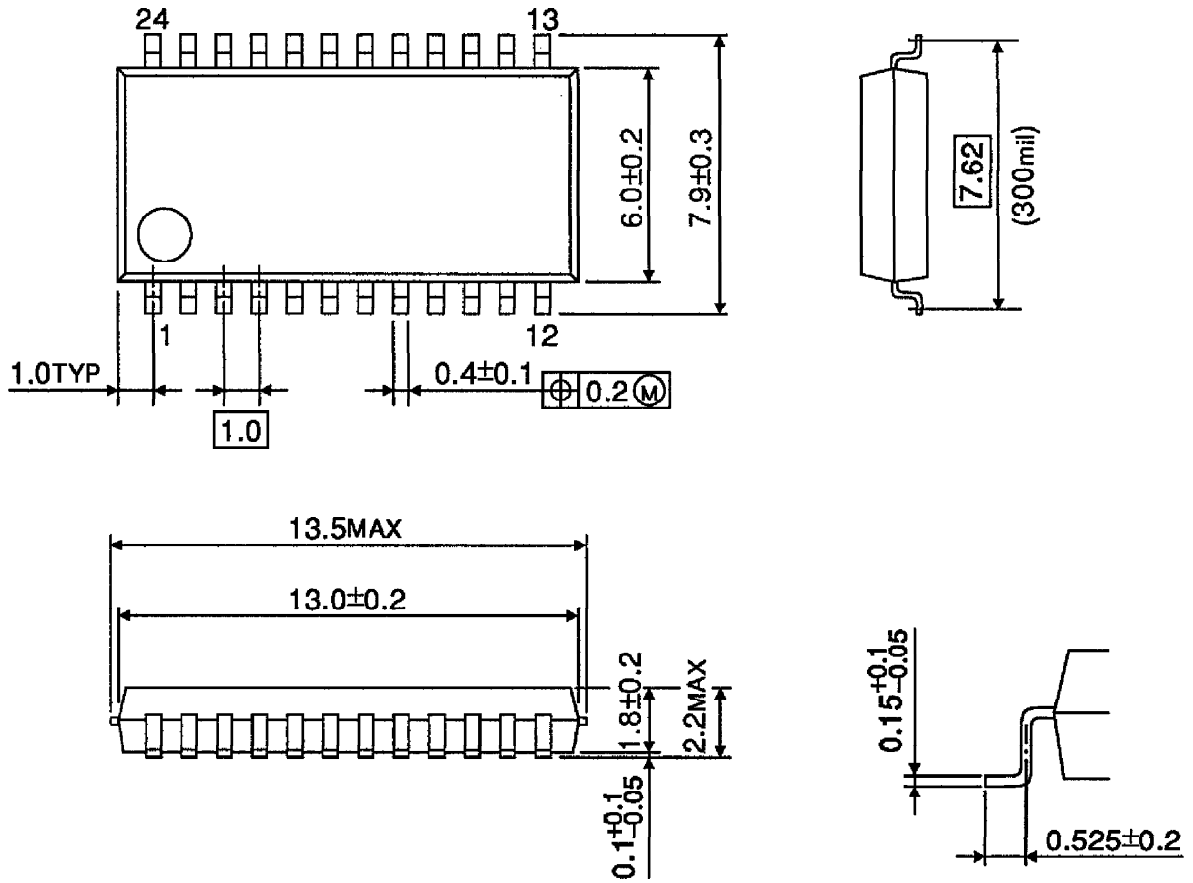

Weight : 0.31 g (Typ.)