



Self Recovering Watchdog

Features

- Self recovering watchdog function: reset goes active after the 1st timeout period, reset goes inactive again after the 2nd timeout period, repeated active reset signal until the system recovers
- Standard timeout period and power-on reset time (100 ms), externally programmable if required
- Unregulated DC monitoring (V_{IN}) with 3 standard or programmable trigger voltages for: power-on reset initialization, advanced power-fail warning (SAVE), reset at power-down (\overline{RES})
- Regulated DC monitoring (V_{DD}): power-on reset initialization enabled only if $V_{DD} \geq 3.5\text{ V}$
- Internal voltage reference
- Works down to 1.6 V supply voltage
- Push-pull or Open drain outputs
- Low current consumption
- Available for normal and extended temperature ranges
- DIP8 and SO8 package

Description

The H6060 is a monolithic low-power CMOS device combining a programmable timer and a series of voltage comparators on the same chip. The device is specially suited for watchdog functions such as microprocessor and supply voltage monitoring. If the μP system malfunctions, the watchdog will recover it by issuing repeated active reset signals. The voltage monitoring part provides double security by combining both the unregulated voltage (V_{IN}) and the regulated voltage (V_{DD}) monitoring simultaneously. The H6060 initializes the power-on reset after V_{IN} reaches V_{SH} (see table 4) and V_{DD} rises above 3.V. If V_{IN} drops below V_{SL} (see table 4), the H6060 gives an advanced warning signal for register saving and if the voltage drops further below V_{RL} (see table 4), \overline{RES} and RES go active. The H6060 functions at any supply voltage down to 1.6 V and is therefore particularly suited for start-up and shut-down control of microprocessor systems.

Applications

- Microprocessor and microcontroller systems
- Point of sales equipment
- Telecom products
- Automotive subsystems

Typical Operating Configuration

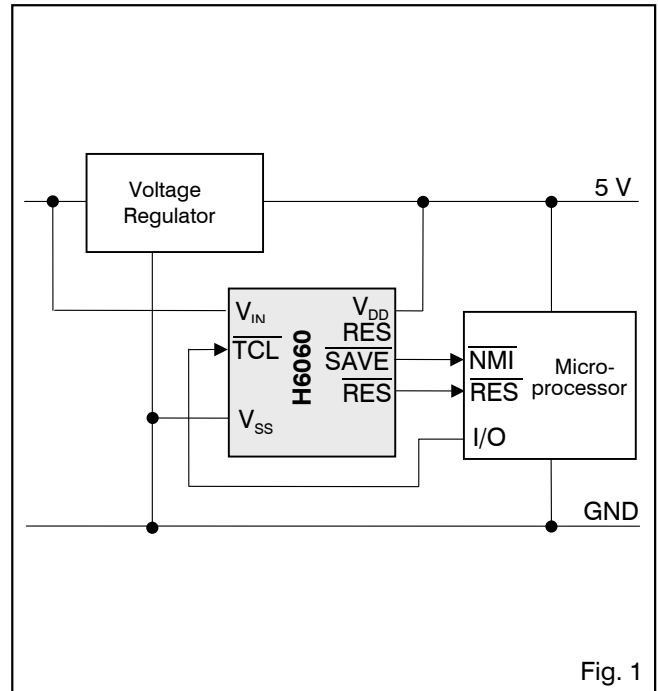

Fig. 1

Pin Assignment

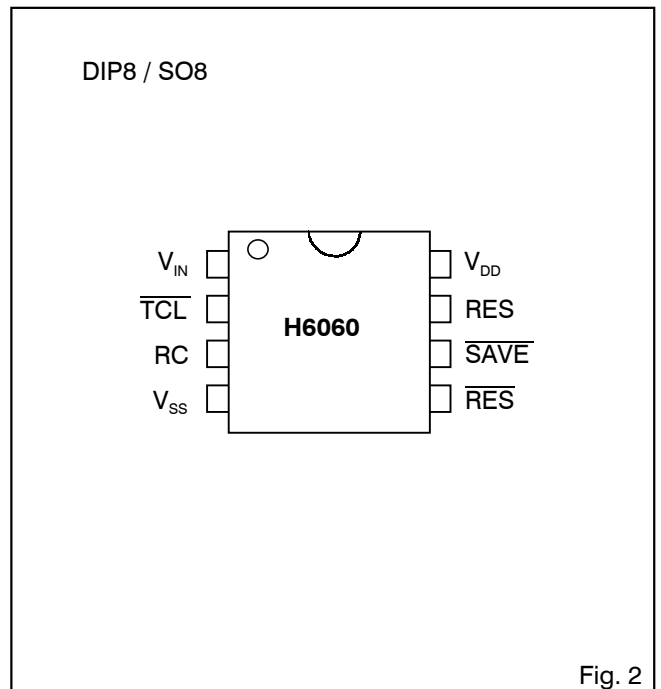

Fig. 2



Absolute Maximum Ratings

Parameter	Symbol	Conditions
Voltage V_{DD} to V_{SS}	V_{DD}	-0.3 to +8 V
Voltage at any pin to V_{SS}	V_{MIN}	-0.3
Voltage at any pin to V_{DD} (except V_{IN})	V_{MAX}	+0.3
Voltage at V_{IN} to V_{SS}	V_{INMAX}	+15 V
Current at any output	I_{MAX}	±10 mA
Storage temperature	T_{STO}	-65...+150 °C

Table 1

Stresses above these listed maximum ratings may cause permanent damage to the device. Exposure beyond specified operating conditions may affect device reliability or cause malfunction.

Handling Procedures

This device has built-in protection against high static voltages or electric fields; however, anti-static

Electrical Characteristics

$V_{DD} = 5.0$ V, $T_A = -40$ to $+85$ °C, unless otherwise specified

Parameter	Symbol	Test Conditions	Min.	Typ.	Max.	Units
V_{DD} activation threshold	V_{ON}	$T_A = 25$ °C	3		3.5	V
V_{DD} deactivation threshold	V_{OFF}	$T_A = 25$ °C		$V_{ON} - 0.3$		V
Supply current	I_{DD}	RC open, TCL at V_{DD} or V_{SS}		80	140	μA
Input V_{IN}, TCL						
Leakage current	I_{IP}	$V_{SS} \leq V_{IP} \leq V_{DD}$; $T_A = 85$ °C		0.005	1	μA
Input current on pin V_{IN}	I_{IN}	Versions 11, 12; $V_{IN} = 10$ V		100	180	μA
TCL input low level	V_{IL}				0.8	V
TCL input high level	V_{IH}		2.4			V
SAVE, RES, RES outputs						
Leakage currents	I_{OLK}	Versions 11, 13, 15; $V_{OUT} = V_{DD}$		0.05	1	μA
Drive currents (all versions)	I_{OL}	$V_{OL} = 0.4$ V	3.2	8		mA
	I_{OL}	$V_{DD} = 3.5$ V; $V_{OL} = 0.4$ V	2			mA
	I_{OL}	$V_{DD} = 1.6$ V; $V_{OL} = 0.4$ V	80			μA
Drive currents (versions 12, 14, 16) ¹⁾	I_{OH}	$V_{OH} = 4.0$ V	3.2	8		mA
	I_{OH}	$V_{DD} = 3.5$ V; $V_{OH} = 2.8$ V	2			mA
	I_{OH}	$V_{DD} = 1.6$ V; $V_{OH} = 1.2$ V	80			μA

¹⁾ Versions: 11, 13, 15 = open drain outputs; 12, 14, 16 = push-pull outputs

Table 3

V_{IN} Surveillance

Voltage thresholds at $T_A = 25$ °C

Version ¹⁾	Comparator Reference	Input Resistance on V_{IN} (R_{VIN})	Threshold			Thresholds Tolerance	Ratio Tolerance ³⁾
			V_{SH}	V_{SL}	V_{RL}		
11, 12	V_{DD}	100kΩ	9.00	8.00	7.00 ²⁾	±5%	±2%
13, 14	V_{DD}	~100MΩ	2.25	2.00	1.75 ²⁾	±5%	±2%
15, 16	Band-gap reference	~100MΩ	2.00	1.95	1.90	±10%	±2%

¹⁾ Versions: 11, 13, 15 = open drain outputs; 12, 14, 16 = push-pull outputs

Table 4

²⁾ at $V_{DD} = 5$ V

³⁾ Threshold ratio tolerance is defined as the tolerance of V_{SH} / V_{SL} and V_{SL} / V_{RL} .

precautions must be taken as for any other CMOS component. Unless otherwise specified, proper operation can only occur when all terminal voltages are kept within the supply voltage range. Unused inputs must always be tied to a defined logic voltage level.

Operating Conditions

Parameter	Symbol	Min.	Typ	Max.	Units
Operating temperature					
Industrial	T_{AI}	-40		+85	°C
Supply voltage	V_{DD}	1.6		5.5	V
Comparator input voltage					
Version 13, 14, 15, 16	V_{IN}	0		V_{DD}	V
Version 11, 12	V_{IN}	0		12	V
RC-oscillator programming (see Fig. 15)					
External capacitance*	C1			1	μF
External resistance	R1	10			kΩ

* Leakage < 1 μA

Table 2



Timing Characteristics

$V_{DD} = 5.0\text{ V}$, $T_A = -40\text{ }^\circ\text{C}$ to $+85\text{ }^\circ\text{C}$, unless otherwise specified

Parameter	Symbol	Test Conditions	Min.	Typ.	Max.	Units
Propagation delays						
TCL to output pins	T_{DIDO}	Excluding debounce time T_{DB}		250	500	ns
V_{IN} to output pins	T_{AIDO}		4	10	μs	
Logic transition times on all output pins	T_{TR}	Load 10 k Ω , 100 pF		30	100	ns
Timeout period	T_{TO}	RC open, unshielded, $T_A = 25\text{ }^\circ\text{C}$	60	100	160	ms
	T_{TO}	RC open, unshielded (not tested)	45		200	ms
T_{TCL} input pulse width	T_{TCL}		150			ns
Power-on reset debounce	T_{DB}			$T_{TO}/64$		ms
V_{IN} low pulse	T_{VINL}	Where debounce time T_{DB} is guaranteed	10			μs

Table 5

Timing Waveforms

Voltage Reaction: V_{DD} Monitoring

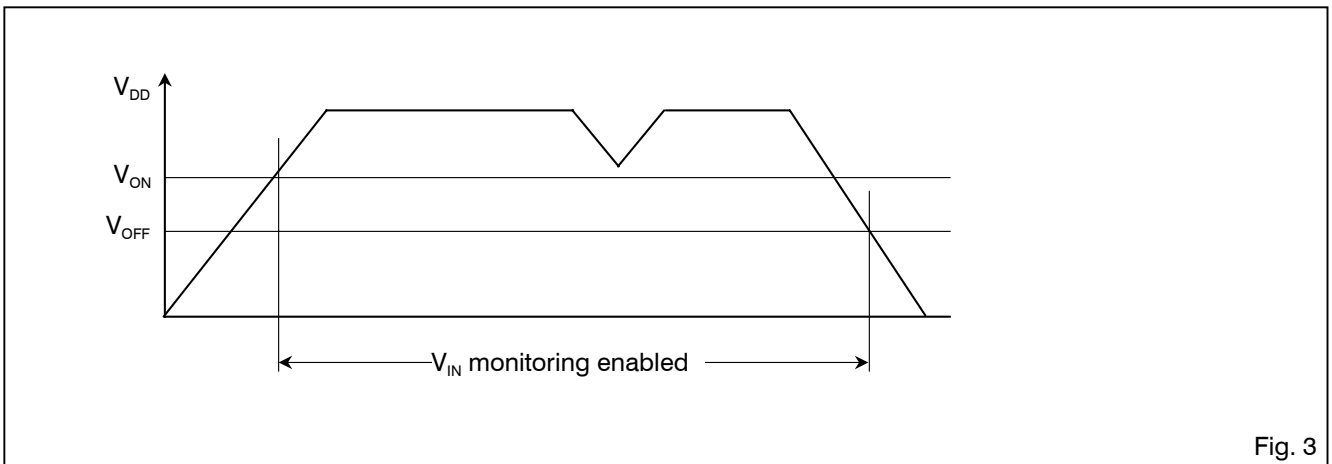

Fig. 3

Voltage Reaction: V_{IN} Monitoring

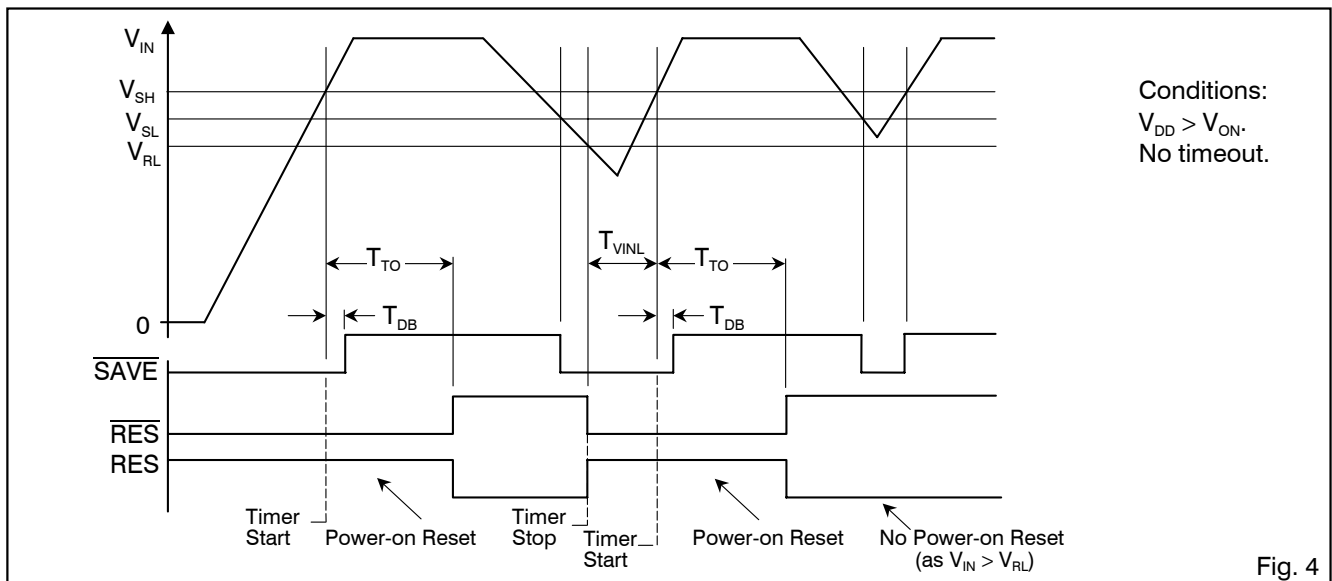
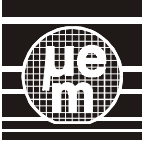
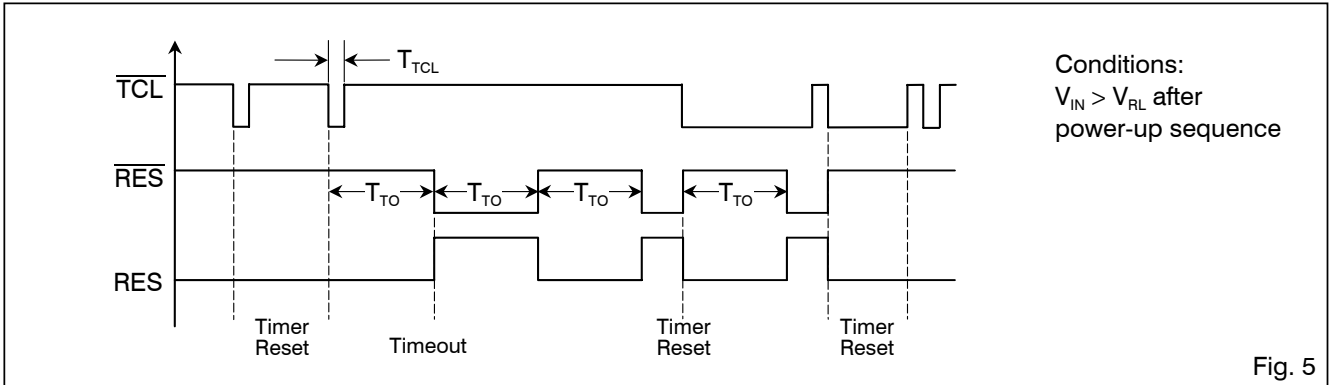

Fig. 4



Timer Reaction



Combined Voltage and Timer Reaction

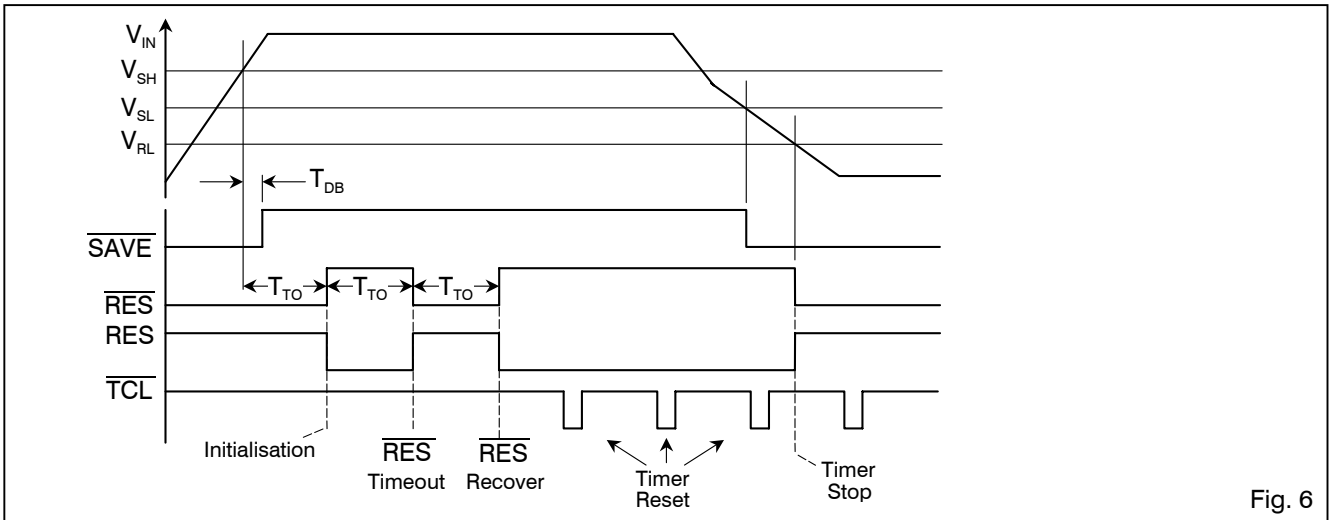

Block Diagram

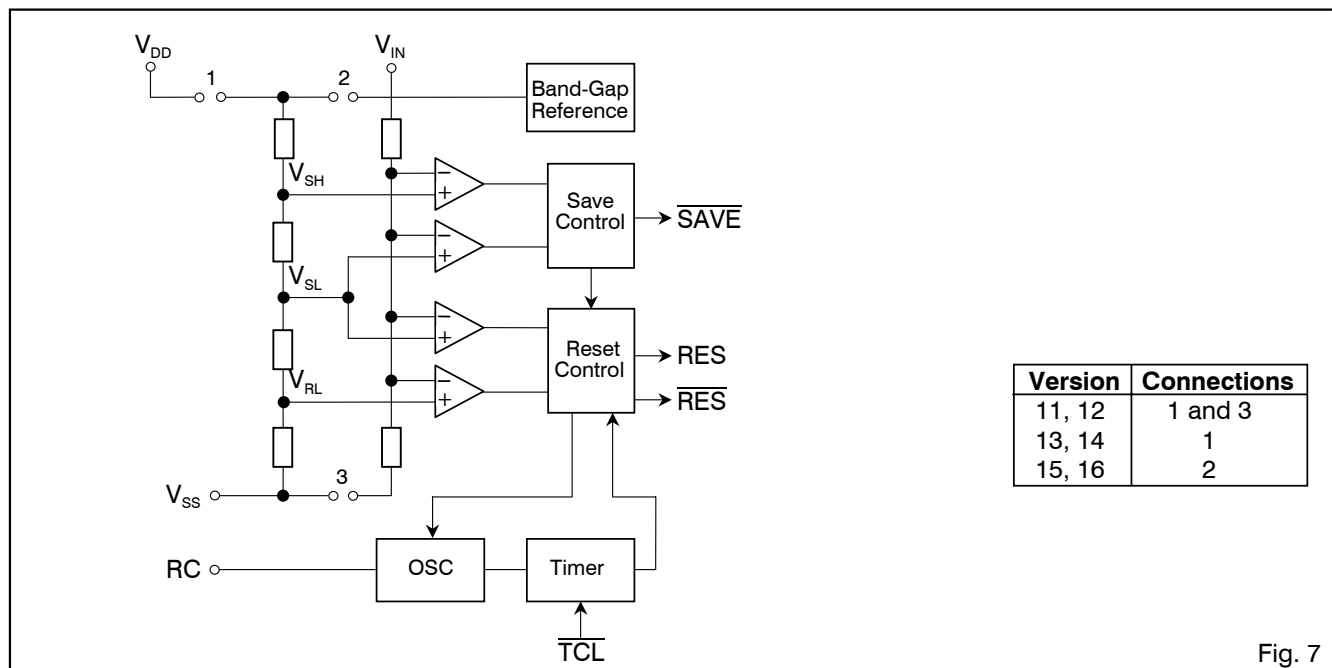



Pin Description

Pin	Name	Function
1	V_{IN}	Voltage sense input
2	\overline{TCL}	Timer clear input signal
3	RC	RC oscillator tuning input
4	V_{SS}	GND terminal
5	\overline{RES}	Active low reset output
6	\overline{SAVE}	Save output
7	RES	Active high reset output
8	V_{DD}	Positive supply voltage terminal

Table 6

Functional Description

Supply Lines

The circuit is powered through the V_{DD} and V_{SS} pins. It monitors both its own V_{DD} supply and a voltage applied to the V_{IN} input.

V_{DD} Monitoring

During power-up the V_{IN} monitoring is disabled and \overline{RES} , RES and \overline{SAVE} stay active low as long as V_{DD} is below V_{ON} (3.5 V). As soon as V_{DD} reaches the V_{ON} level, the state of the outputs depend on the watchdog timer and the voltage at V_{IN} relative to the thresholds (see Fig. 4). If the supply voltage V_{DD} falls back below V_{OFF} ($V_{ON} - 0.3$ V) the watchdog timer and the V_{IN} monitoring are disabled and the outputs \overline{RES} , RES and \overline{SAVE} become active. The V_{DD} line should be free of voltage spikes.

V_{IN} Monitoring

The analog voltage comparators compare the voltage applied to V_{IN} (typically connected to the input of the voltage regulator) with the stabilized supply voltage V_{DD} (versions 11, 12, 13, 14) or with the bandgap voltage (versions 15, 16) (see Fig. 7). At power-up, when V_{DD} reached V_{ON} and V_{IN} reaches the V_{SH} level, the \overline{SAVE} output goes inactive, and the timer starts running, setting \overline{RES} and RES in active after the time T_{TO} (see Fig. 4). If V_{IN} falls below V_{SL} , the \overline{SAVE} output goes active and stays active until V_{IN} rises again above V_{SH} . If V_{IN} falls below the voltage V_{RL} , \overline{RES} and RES will become active and the on-chip timer will stop. When V_{IN} rises again above V_{SH} , the timer will initiate a power-up sequence. The RES and \overline{RES} outputs may however be influenced independently of the voltage V_{IN} by the timer action, see section "Combined Voltage and Timer Action". Monitoring the rough DC side of the regulator, as shown in Fig. 12, is the only way to have advanced warning of power-down. Spikes on V_{IN} should be filtered if they are likely to exceed the value ($V_{SL} - V_{RL}$).

The combination of V_{IN} and V_{DD} monitoring provide high system security: if V_{IN} rises much faster than V_{DD} , then the device starts the power-on sequence only when V_{DD} reached V_{ON} (Fig. 11). Short circuits on the regulated supply voltage can be detected.

Voltage Thresholds on V_{IN}

The H6060 is available with 3 different sets of thresholds:

Version 11, 12: have an internal voltage divider for direct monitoring of the unregulated voltage without external components.

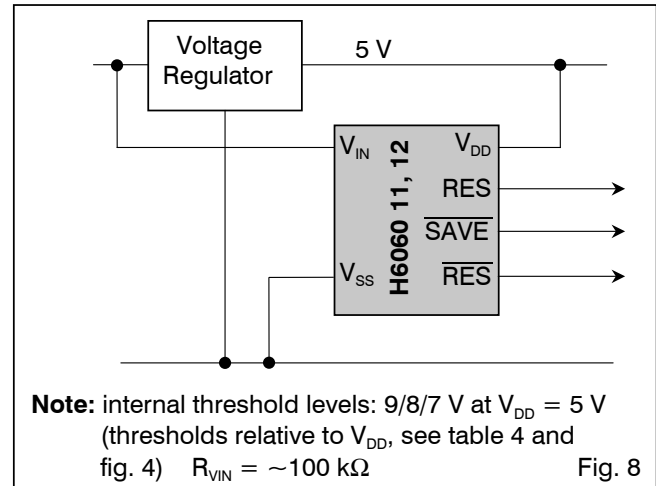

Version 13, 14: monitor the unregulated voltage and are ideal for programming of the V_{IN} voltage thresholds. Fixed resistor values can be used for programming.

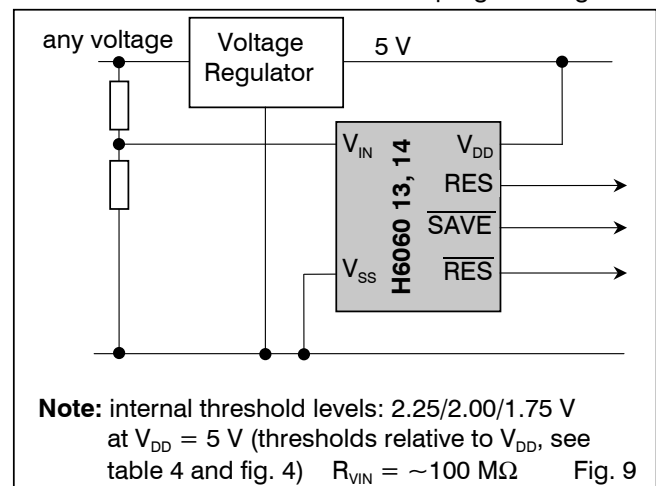

Version 15, 16: monitor the regulated voltage. They are suited to applications where the unregulated voltage is not available. (The tolerance is $\pm 10\%$, see table 4. For tighter tolerances, trimming can be used, see fig. 10).

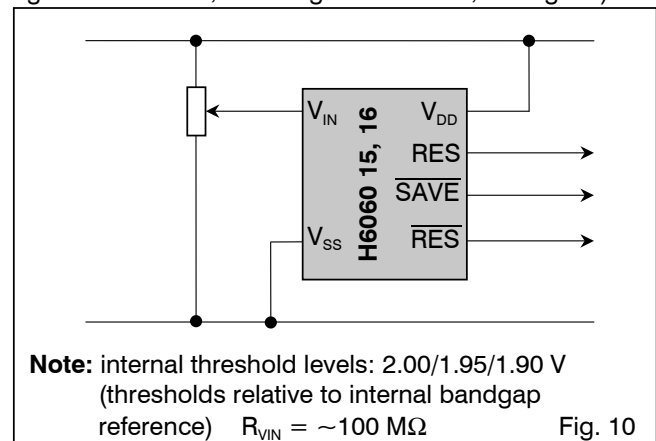



Monitoring of the unregulated voltage requires versions 11, 12, 13 and 14. These versions are based on the principle that V_{DD} rises with V_{IN} on power-up and V_{DD} holds up for a certain time after V_{IN} starts dropping on power-down. The versions 11 and 12 have a 100 k Ω nominal resistance from V_{IN} to V_{SS} (internal voltage divider). The versions 13, 14, 15 and 16 have high impedance V_{IN} inputs (see fig. 7 and table 4) for external threshold voltage programming by a voltage divider on pin V_{IN} . The levels obtained are proportional to the internal levels V_{SH} , V_{SL} and V_{RL} on the chip itself (see Electrical Specifications).

Timer Programming

With pin RC unconnected, the on-chip RC oscillator together with its divider chain give a timeout T_{TO} of typically 100 ms. To program different T_{TO} , an approximation for calculating component values is given by the formula:

$$T_{TO} = \left[0.75 + \frac{(32 + C_1) \cdot 2}{5.5 + \frac{V_{DD} - 1}{R_1}} \right] 8.192$$

$$R_{1min.} = 10 \text{ k}\Omega, C_{1max.} = 1 \mu\text{F}$$

If R_1 is in M Ω and C_1 in pF, T_{TO} will be in ms.

A resistor decreases and a capacitor increases the interval to timeout. Excellent temperature stability of T_{TO} can be achieved by using external components. A precise square wave of period $2 \times T_{TO}$ is generated at the outputs \overline{RES} and RES when \overline{TCL} is tied to either V_{DD} or V_{SS} . The oscillator and watchdog timer start running when both V_{IN} is greater than V_{SH} (see fig. 6) and V_{DD} is

greater than V_{ON} (see fig. 3).

They will remain running while both V_{IN} is greater than V_{RL} and V_{DD} is greater than V_{OFF} (see fig. 3).

Timer Clearing and \overline{RES} /RES Action

A negative edge or a negative pulse at the \overline{TCL} input for longer than 150 ns will reset the timer and set \overline{RES} and RES inactive. If a further \overline{TCL} signal edge or pulse is applied before T_{TO} timeout, \overline{RES} and RES will remain inactive and the timer will again be reset to zero (see fig. 5). If no \overline{TCL} signal is applied before the T_{TO} timeout, \overline{RES} and RES will start to generate square waves of period $2 \times T_{TO}$ starting with the inactive state. The watchdog will remain in this state until the next \overline{TCL} signal appears, or until a fresh power-up sequence.

Combined Voltage and Timer Action

The combination of voltage and timer actions is illustrated by the sequence of events shown in fig. 6. One timeout period after V_{IN} reaches V_{SH} , during power-up, \overline{RES} and RES go inactive. A \overline{TCL} pulse will have no effect until this power-on reset delay is completed. After completing the power-up sequence the watchdog timer starts acting. If no \overline{TCL} pulse occurs, \overline{RES} and RES go active after one timeout period T_{TO} . After each subsequent timeout period, without a timer clear pulse at \overline{TCL} , \overline{RES} and RES change polarity providing square wave signals. A \overline{TCL} pulse clears the watchdog timer and causes \overline{RES} and RES to go inactive. A voltage drop below the V_{RL} level overrides the timer and immediately forces \overline{RES} , RES and \overline{SAVE} active. Any further \overline{TCL} pulse has no effect until the next power-up sequence is completed.

Typical Applications

Microprocessor Watchdog with Power-On Reset and Voltage Monitor

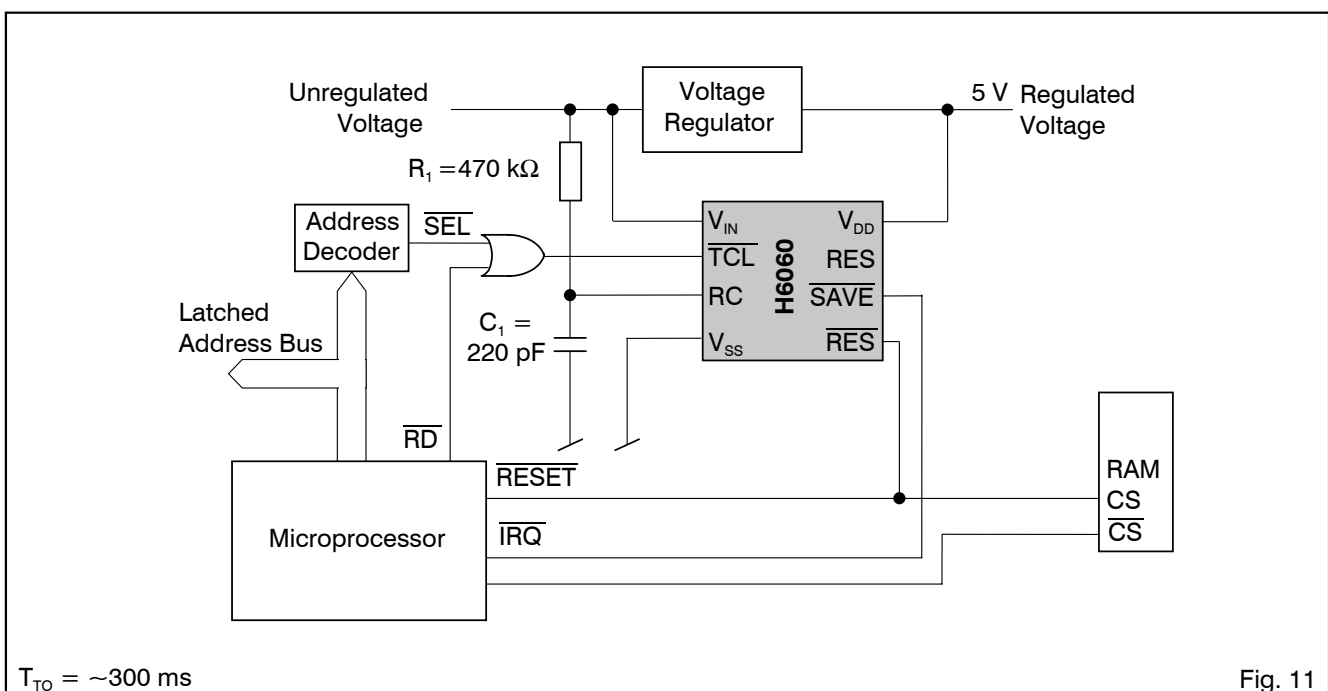
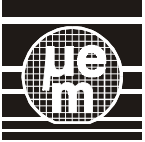
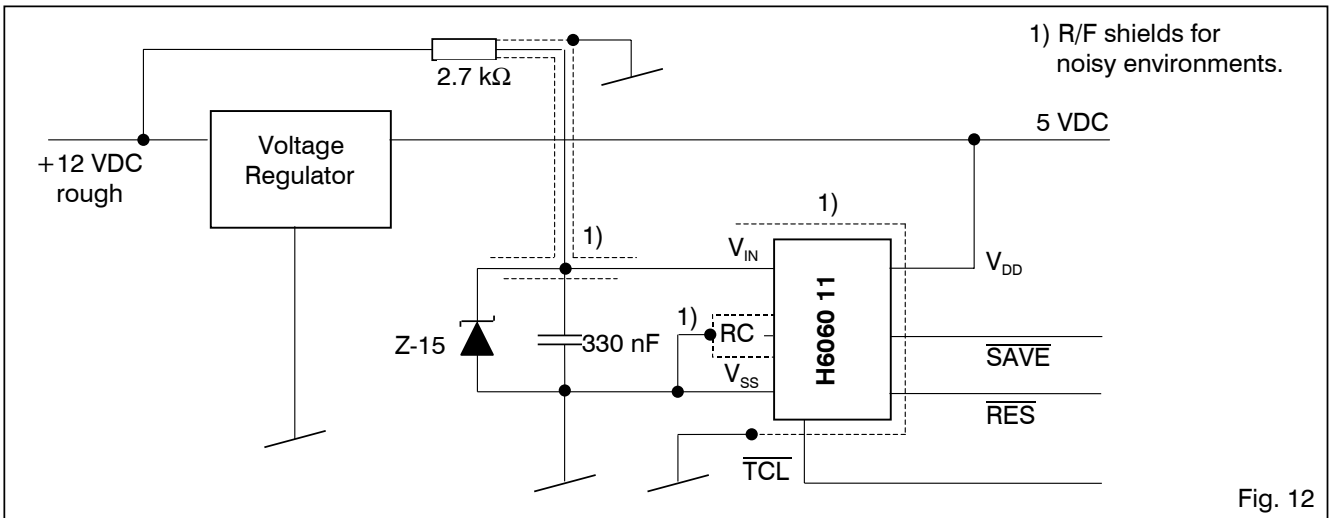

Fig. 11



Voltage Monitor with Spike Suppression



Watchdog and Power-On Reset

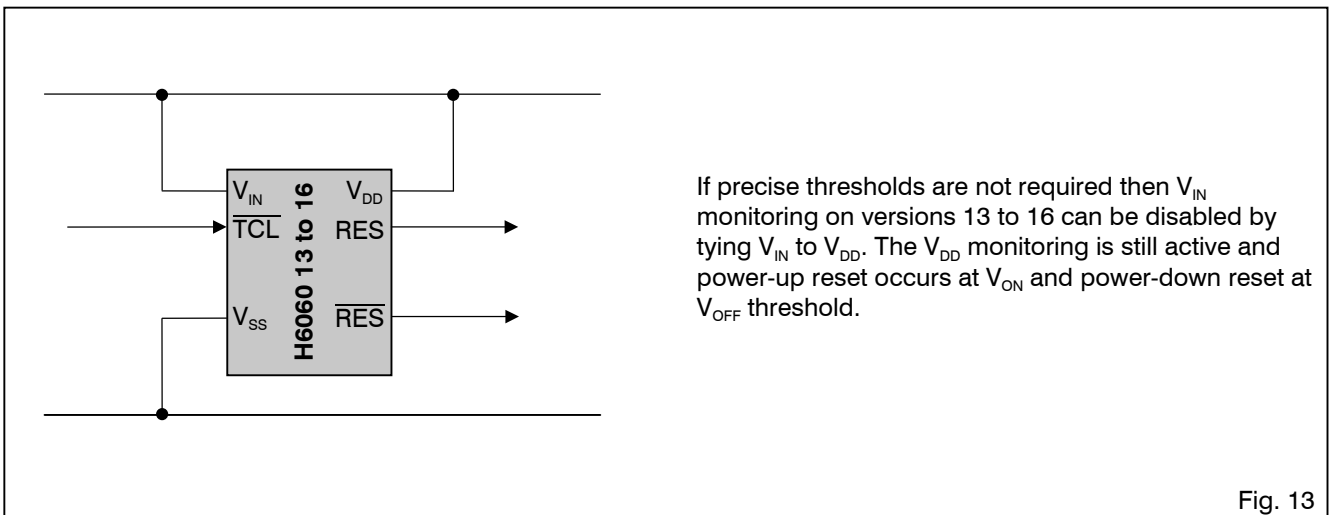

External Programming of RC Oscillator

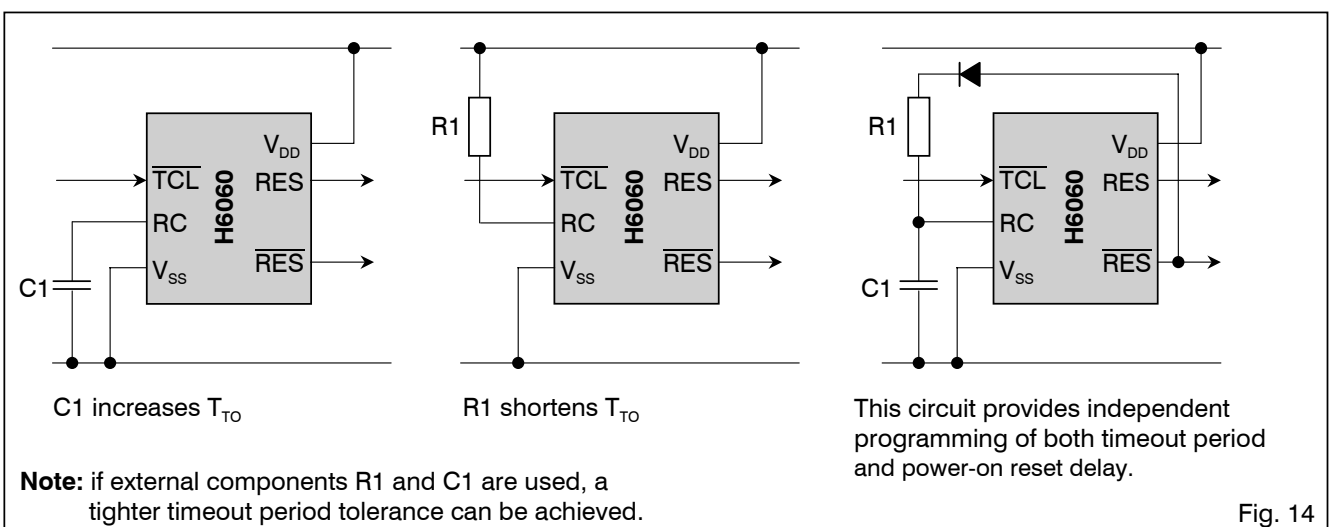



Package Information

Dimensions of 8-Pin SOIC Package

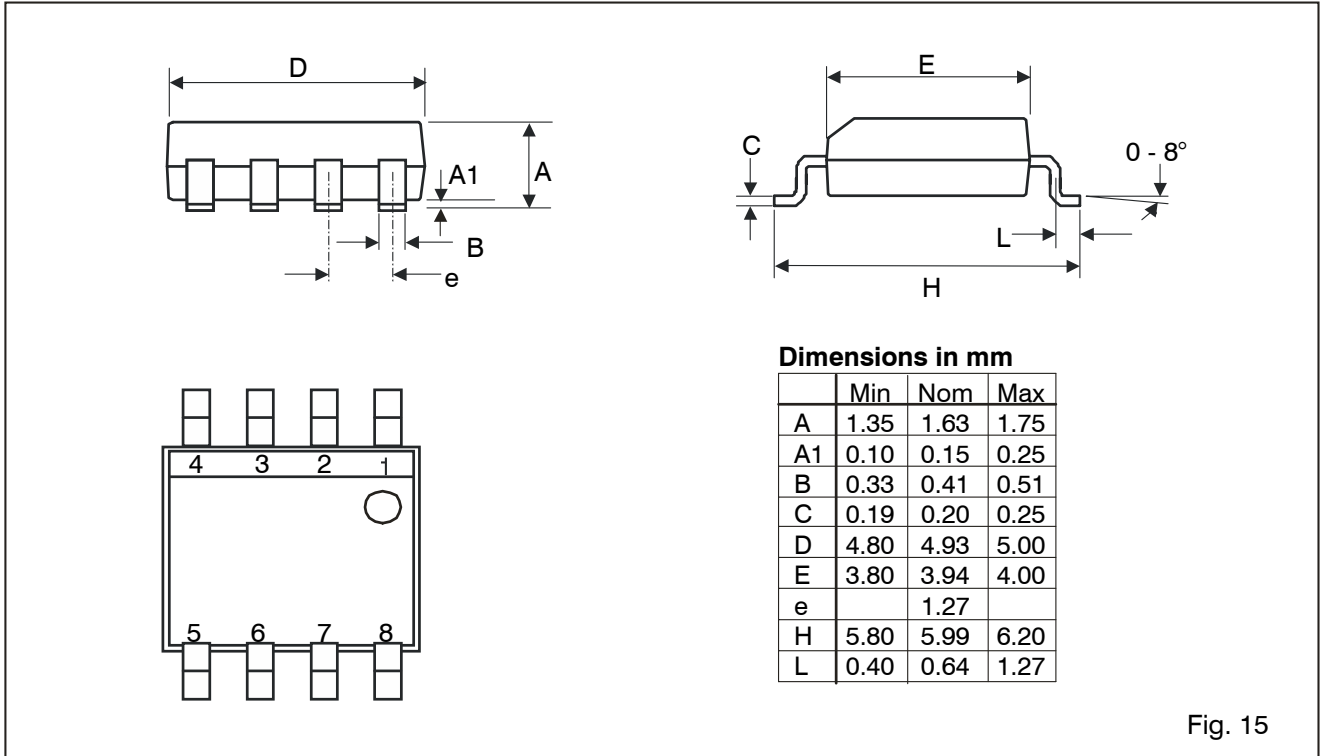

Dimensions of 8-Pin Plastic DIP Package

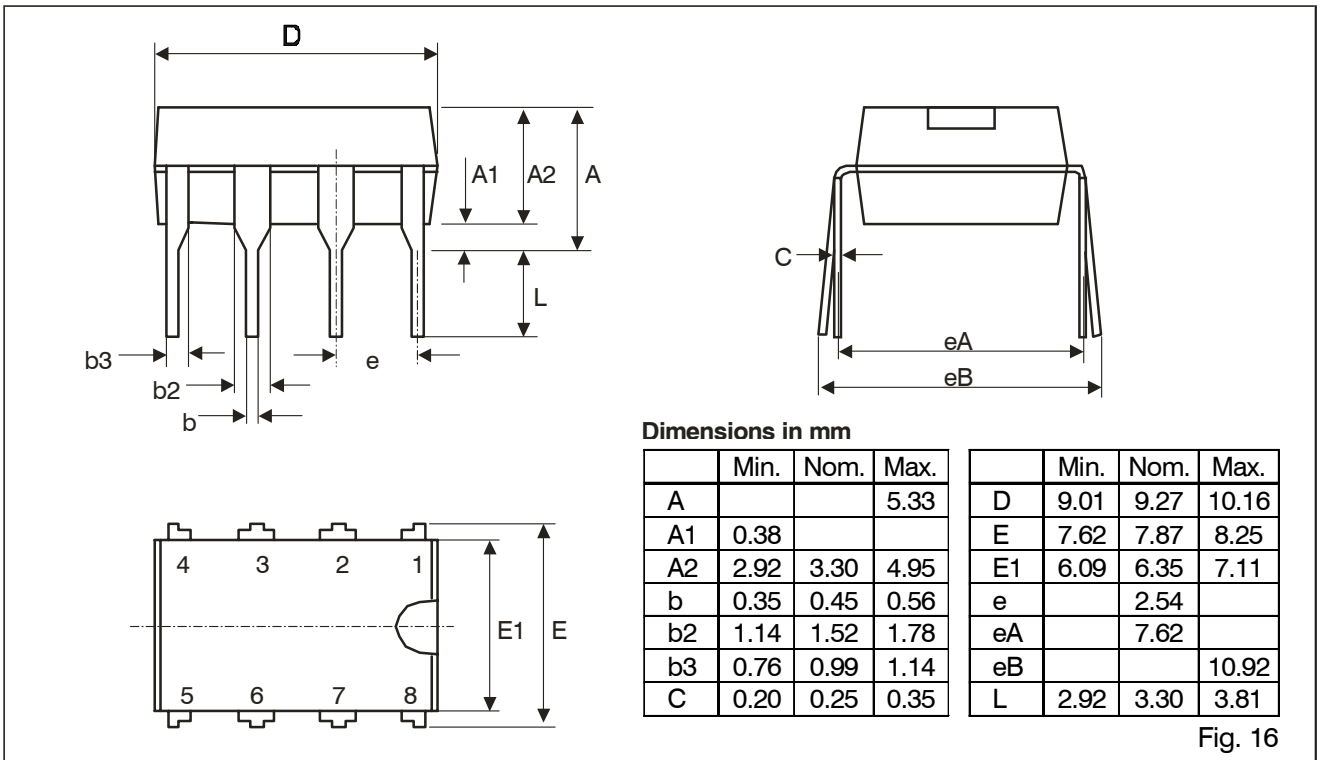



Ordering Information

When ordering please specify complete part number.

Part Number	Version	Threshold (see Table 4)	Output	Package	Delivery Form	Package Marking (first line)	Temperature
H6060V11SO8A *	V11	8.00	Open drain	8-pin SOIC	Stick	606011	-40°C to +85°C
H6060V11SO8B *				Tape&Reel	606011		
H6060V11DL8A *				8-pin plastic DIP	Stick	H606011	
H6060V13SO8A *	V13	2.00		8-pin SOIC	Stick	606013	
H6060V13SO8B *				Tape&Reel	606013		
H6060V13DL8A *				8-pin plastic DIP	Stick	H606013	
H6060V15SO8A	V15	1.95		8-pin SOIC	Stick	606015	
H6060V15SO8B				Tape&Reel	606015		
H6060V15DL8A				8-pin plastic DIP	Stick	H606015	
H6060V12SO8A *	V12	8.00	Push-pull	8-pin SOIC	Stick	606012	
H6060V12SO8B *				Tape&Reel	606012		
H6060V12DL8A *				8-pin plastic DIP	Stick	H606012	
H6060V14SO8A	V14	2.00		8-pin SOIC	Stick	606014	
H6060V14SO8B				Tape&Reel	606014		
H6060V14DL8A				8-pin plastic DIP	Stick	H606014	
H6060V16SO8A	V16	1.95		8-pin SOIC	Stick	606016	
H6060V16SO8B				Tape&Reel	606016		
H6060V16DL8A				8-pin plastic DIP	Stick	H606016	

* = non stock items. Might be available on request and upon minimum order quantity (please contact EM Microelectronic)

EM Microelectronic-Marin SA cannot assume any responsibility for use of any circuitry described other than entirely embodied in an EM Microelectronic-Marin SA product. EM Microelectronic-Marin SA reserves the right to change the circuitry and specifications without notice at any time. You are strongly urged to ensure that the information given has not been superseded by a more up-to-date version.

© 2002 EM-Microelectronic-Marin SA, 03/02, Rev. H/457