

BIPOLAR ANALOG INTEGRATED CIRCUIT

μ PC1652G

SILICON MONOLITHIC BIPOLAR INTEGRATED CIRCUIT

WIDE BAND AMPLIFIER

DESCRIPTION

The μ PC1652G is a silicon monolithic integrated circuit especially designed as a wide band amplifier covering HF band through UHF band.

FEATURES

- Excellent frequency response : 1 200 MHz TYP. @ 3 dB down
- High power gain : 18 dB TYP. @ f = 500 MHz
- Low voltage operation : $V_{CC} = 5$ V
- SOP package

PIN CONNECTIONS

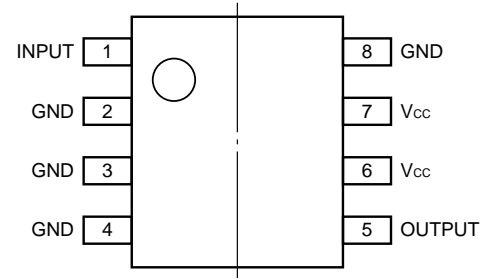

ABSOLUTE MAXIMUM RATINGS ($T_A = +25$ °C)

Supply Voltage	V_{CC}	7	V
Total Power dissipation	P_D	440	mW
Operating Ambient Temperature	T_A	-20 to +75	°C
Storage Temperature	T_{stg}	-40 to +125	°C

EQUIVALENT CIRCUIT

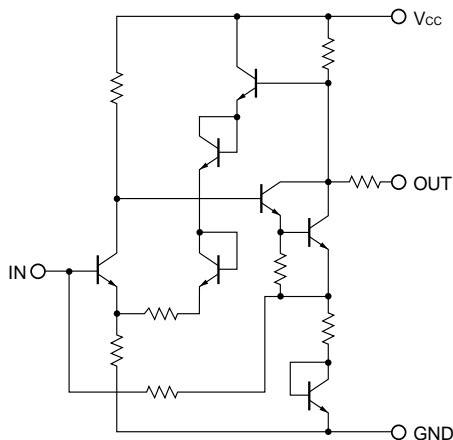

NEC cannot assume any responsibility for any circuits shown or represent that they are free from patent infringement

ELECTRICAL CHARACTERISTICS ($T_A = +25$ °C, $V_{CC} = 5$ V)

CHARACTERISTIC	SYMBOL	MIN.	TYP.	MAX.	UNIT	TEST CONDITIONS
Circuit Current	I_{CC}	15	20	25	mA	No signals
Power Gain	G_P	16	18	20	dB	f = 500 MHz
Noise Figure	NF		5.5	6.5	dB	f = 500 MHz
Band Width	BW	1000	1200		MHz	3 dB down below flat gain
Isolation	I_{SO}	23	26		dB	f = 500 MHz
Input Return Loss	$ S_{11} $	17	20		dB	f = 500 MHz
Output Return Loss	$ S_{22} $	12	15		dB	f = 500 MHz
Maximum Output Level	P_O	3	5		dBm	f = 500 MHz

The information in this document is subject to change without notice. Before using this document, please confirm that this is the latest version.

Not all devices/types available in every country. Please check with local NEC representative for availability and additional information.

TYPICAL CHARACTERISTICS (T_A = +25 °C)

CIRCUIT CURRENT vs. SUPPLY VOLTAGE

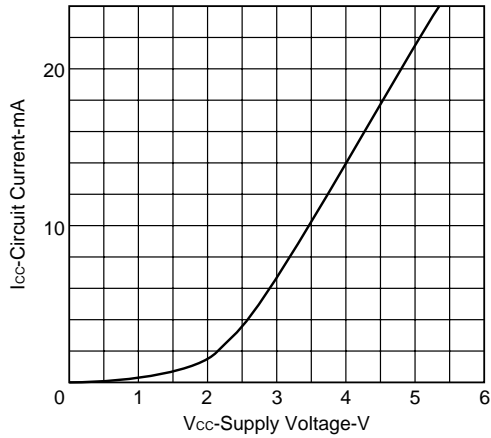

INPUT POWER vs. OUTPUT POWER

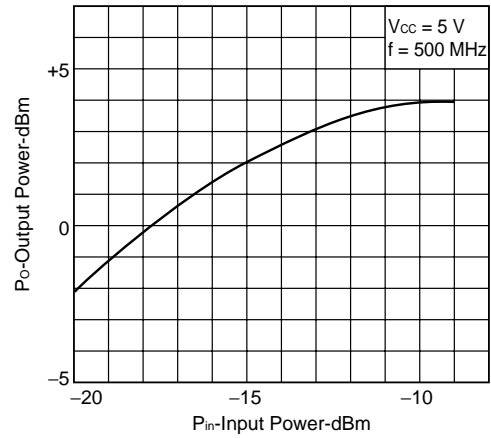

NOISE FIGURE AND POWER GAIN vs. FREQUENCY

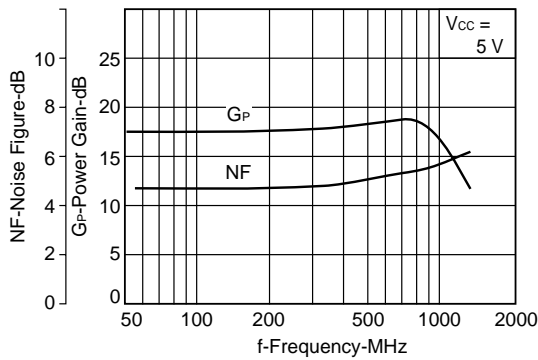

INPUT AND OUTPUT RETURN LOSS vs. FREQUENCY

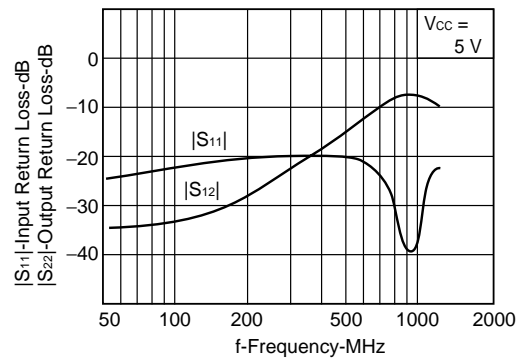

ISOLATION vs. FREQUENCY

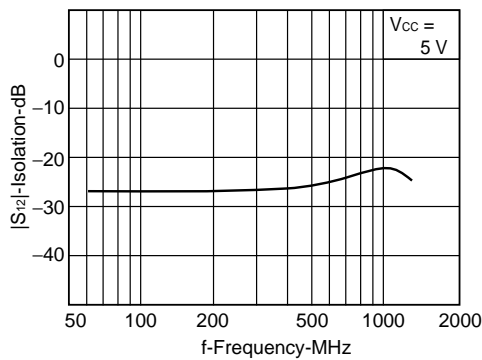

★ PACKAGE DIMENSIONS

8 PIN PLASTIC SOP (225 mil) (UNIT: mm)

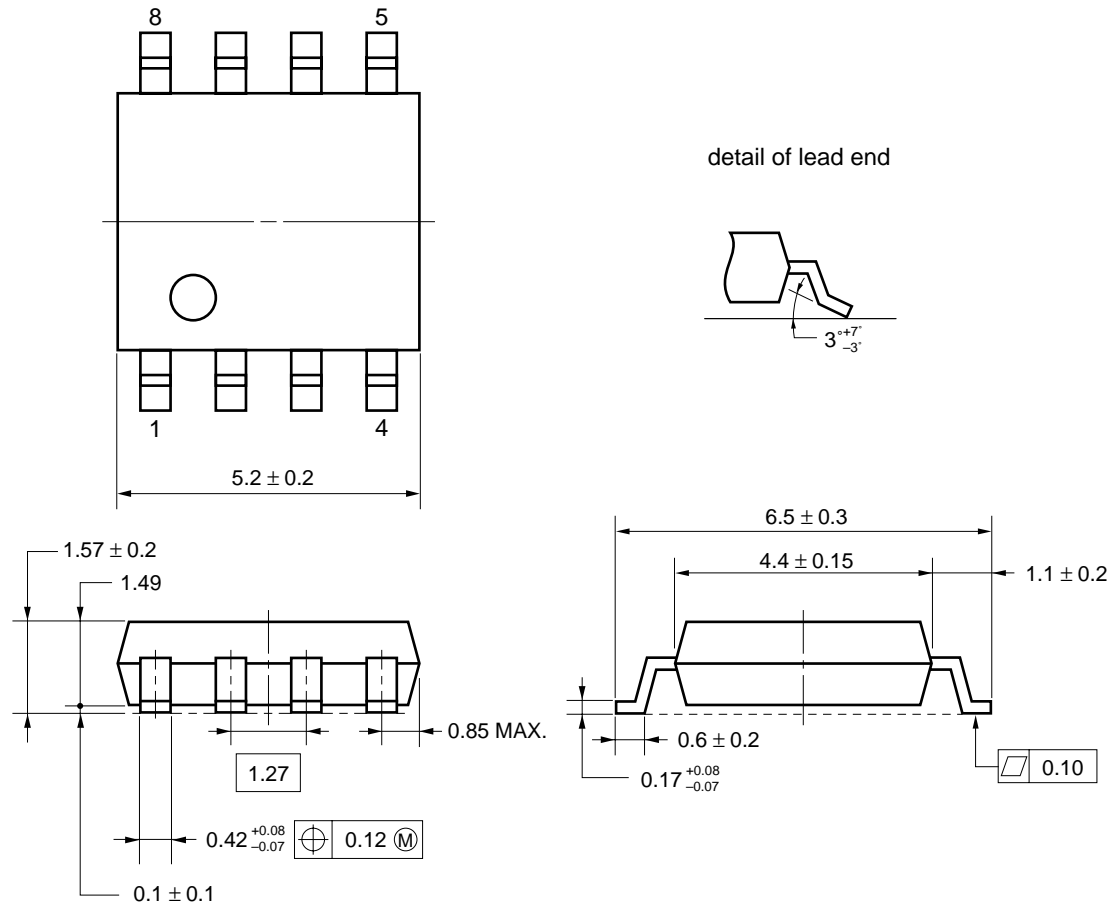

NOTE Each lead centerline is located within 0.12 mm of its true position (T.P.) at maximum material condition.

NOTE ON CORRECT USE

- (1) Observe precautions for handling because of electro-static sensitive devices.
- (2) Form a ground pattern as wide as possible to keep minimum ground impedance (to prevent undesired oscillation).
- (3) Keep the track length of the ground pins as short as possible.
- (4) The bypass capacitor should be attached to the V_{CC} pin.
- (5) The DC cut capacitor must be each attached to the input and output pins.

RECOMMENDED SOLDERING CONDITIONS

This product should be soldered in the following recommended conditions. Other soldering methods and conditions than the recommended conditions are to be consulted with our sales representatives.

μPC1652G

Soldering Method	Soldering Conditions	Recommended Condition Symbol
Infrared ray reflow	Package peak temperature: 235 °C, Hour: within 30 s. (more than 210 °C), Time: 3 times, Limited days: no. ^{Note}	IR35-00-3
VPS	Package peak temperature: 215 °C, Hour: within 40 s. (more than 200 °C), Time: 3 times, Limited days: no. ^{Note}	VP15-00-3
Wave soldering	Soldering tub temperature: less than 260 °C, Hour: within 10 s. Time: 1 time, Limited days: no. ^{Note}	WS60-00-1
Pin part heating	Pin area temperature: less than 300 °C, Hour: within 3 s/pin. Limited days: no. ^{Note}	

Note It is the storage days after opening a dry pack, the storage conditions are 25 °C, less than 65 % RH.

Caution The combined use of soldering method is to be avoided (However, except the pin area heating method).

For details of recommended soldering conditions for surface mounting, refer to information document **SEMICONDUCTOR DEVICE MOUNTING TECHNOLOGY MANUAL (C10535E)**.

[MEMO]

[MEMO]

[MEMO]

- **The information in this document is subject to change without notice. Before using this document, please confirm that this is the latest version.**
 - No part of this document may be copied or reproduced in any form or by any means without the prior written consent of NEC Corporation. NEC Corporation assumes no responsibility for any errors which may appear in this document.
 - NEC Corporation does not assume any liability for infringement of patents, copyrights or other intellectual property rights of third parties by or arising from use of a device described herein or any other liability arising from use of such device. No license, either express, implied or otherwise, is granted under any patents, copyrights or other intellectual property rights of NEC Corporation or others.
 - Descriptions of circuits, software, and other related information in this document are provided for illustrative purposes in semiconductor product operation and application examples. The incorporation of these circuits, software, and information in the design of the customer's equipment shall be done under the full responsibility of the customer. NEC Corporation assumes no responsibility for any losses incurred by the customer or third parties arising from the use of these circuits, software, and information.
 - While NEC Corporation has been making continuous effort to enhance the reliability of its semiconductor devices, the possibility of defects cannot be eliminated entirely. To minimize risks of damage or injury to persons or property arising from a defect in an NEC semiconductor device, customers must incorporate sufficient safety measures in its design, such as redundancy, fire-containment, and anti-failure features.
 - NEC devices are classified into the following three quality grades:
"Standard", "Special", and "Specific". The Specific quality grade applies only to devices developed based on a customer designated "quality assurance program" for a specific application. The recommended applications of a device depend on its quality grade, as indicated below. Customers must check the quality grade of each device before using it in a particular application.
 - Standard: Computers, office equipment, communications equipment, test and measurement equipment, audio and visual equipment, home electronic appliances, machine tools, personal electronic equipment and industrial robots
 - Special: Transportation equipment (automobiles, trains, ships, etc.), traffic control systems, anti-disaster systems, anti-crime systems, safety equipment and medical equipment (not specifically designed for life support)
 - Specific: Aircraft, aerospace equipment, submersible repeaters, nuclear reactor control systems, life support systems or medical equipment for life support, etc.
- The quality grade of NEC devices is "Standard" unless otherwise specified in NEC's Data Sheets or Data Books. If customers intend to use NEC devices for applications other than those specified for Standard quality grade, they should contact an NEC sales representative in advance.