



M65849BFP

SINGLE CHIP SURROUND PROCESSOR

DESCRIPTION

The M65849BFP is a CMOS IC built-in Digital circuit and mixing amplifiers. It is suitable for adding effects to Mini Stereo, CD-Radio Cassette and TV. This COMS IC can be used dolby surround.

FEATURES

- Built-in digital delay , mixing amplifiers, input output selector achieve a surround system with a single chip .
- Delay volume , feedback volume Built-in
- ADM digital delay , 16kbit SRAM Built-in
- Selection of delay time in a range between 9.2msec and 196.6msec 8 increments.
- 32 pin SSOP package (32P2U-B)
- Built-in automatic reset circuit activated with power on
- 5V single power supply

RECOMMENDED OPERATING CONDITION

- Supply voltage range..... $V_{cc}=4.5 \sim 5.5V$
- Rated supply voltage..... $V_{cc}=5V$

PIN CONFIGURATION

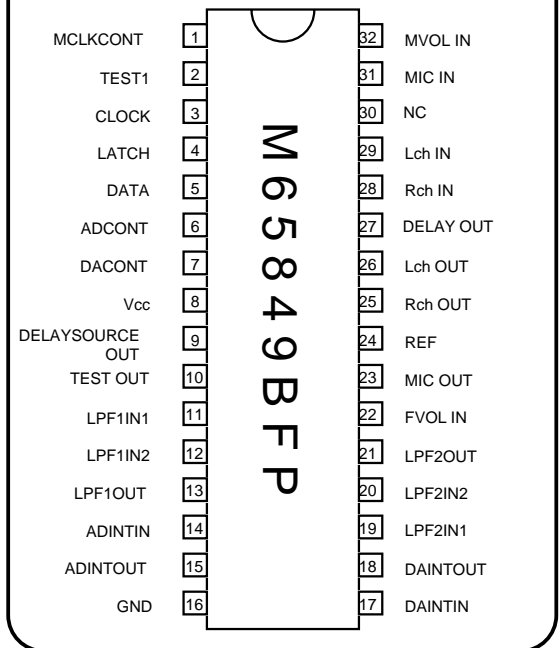

SYSTEM CONFIGURATION

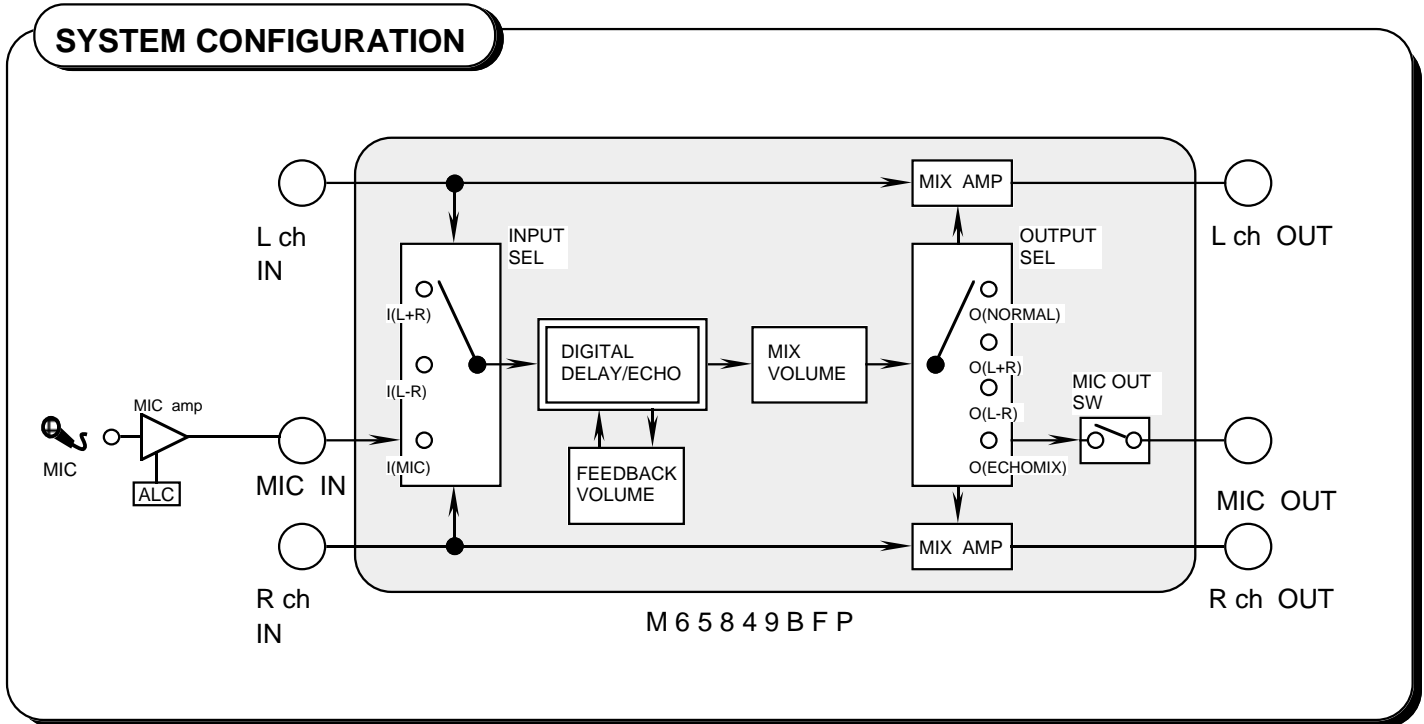



M65849BFP

SINGLE CHIP SURROUND PROCESSOR

Block Diagram

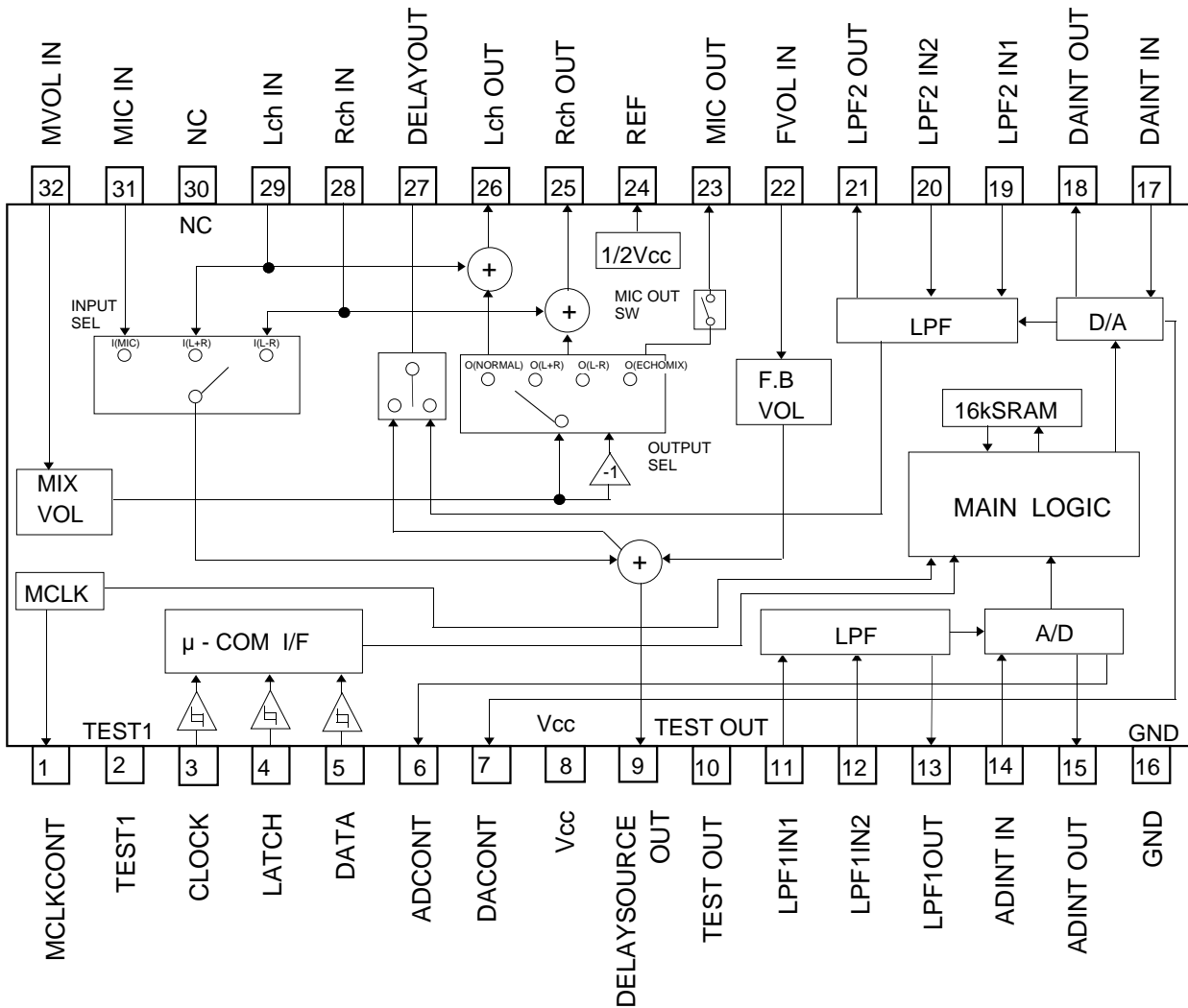

:Schmitt Trigger Buffer

NC :Nonconnect(This terminal can use relay terminal)



SINGLE CHIP SURROUND PROCESSOR

Pin Description

No.	Symbol	Name	I/O	Function
1	MCLKCONT	Oscillator Input	I	Controls built-in clock generation circuit with external R
2	TEST1	Test pin	I	Test mode change "H" Normal / "L" Test (Be sure connect to Vcc at Normal mode)
3	CLOCK	CLOCK	I	Clock input via serial bus
4	LATCH	LATCH	I	Latch input via serial bus
5	DATA	DATA	I	Data input via serial bus
6	AD CONT	A/D Control	—	Decide the time constant of A/D
7	DA CONT	D/A Control	—	Decide the time constant of D/A
8	Vcc	Power Supply	—	
9	DELAYSOURCE OUT	Delay source output	O	(L+R) or (L-R) or (MIC) signal Output
10	TEST OUT	Test output	O	Memory /Mute /Sampling Data Output (Test mode) (Be sure to open at Normal mode)
11	LPF1 IN 1	Low Pass Filter 1 Input 1	I	Prefilter placed before A/D convertor for digital delay
12	LPF1 IN 2	Low Pass Filter 1 Input 2	I	
13	LPF1 OUT	Low Pass Filter 1 Output	O	
14	AD INT IN	A/D Integrator Input	I	To form D/A convertor Integrator by connecting external capacitor
15	AD INT OUT	A/D Integrator Output	O	
16	GND	GND	—	



SINGLE CHIP SURROUND PROCESSOR

No.	Symbol	Name	I/O	Function
17	DAINT IN	D/A Integrator Input	I	Form Integrator With External C
18	DAINT OUT	D/A Integrator Output	O	
19	LPF 2 IN 1	Low Pass Filter 2 Input1	I	Form Low Pass Filter With External C,R
20	LPF 2 IN 2	Low Pass Filter 2 Input 2	I	
21	LPF 2 OUT	Low Pass Filter 2 Output	O	
22	FVOL IN	Feedback Volume Input	I	Feedback Volume Input
23	MIC OUT	Microphone Output	O	Microphone Output
24	REF	Reference	—	1/2 Vcc Output , Connect External C
25	Rch OUT	Rch Output	O	Rch Mixing Output
26	Lch OUT	Lch Output	O	Lch Mixing Output
27	DELAYOUT	DELAY Output	O	Delay Signal Output
28	Rch IN	Rch Input	I	Rch Input
29	Lch IN	Lch Input	I	Lch Input
30	NC	Nonconnect	—	This terminal can use relay terminal for external
31	MIC IN	Microphone Input	I	Microphone Input
32	MVOL IN	Mix Volume Input	—	Mix Volume Input



M65849BFP

SINGLE CHIP SURROUND PROCESSOR

Operation Mode Settings.

Operation mode is controlled by the 16-bit serial data inputted in accordance with the following timing.

- The (DATA is reading at the rising edge of the CLOCK and the last 16-bits are loaded at the rising edge of the LATCH.

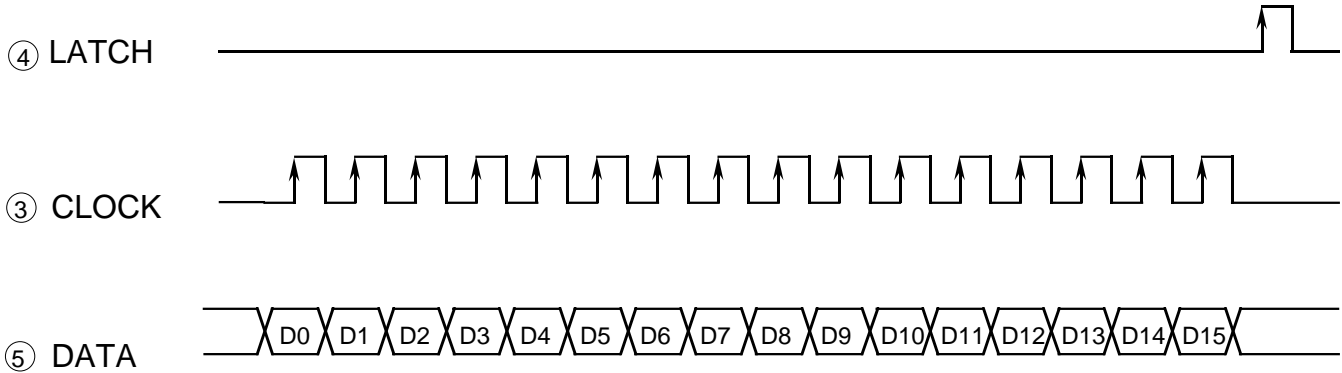

Data No.	Control Block	Control Explanation
D0	DELAY TIME	There are 8 kinds of Delay Time which are from 9.2ms to 196.6ms.
D1		
D2		
D3	INPUT SELECTOR	This is the input selector which selects (CLOCKOFF),(L+R), (L-R) or(MIC).
D4		
D5	OUTPUT SELECTOR	This is the output selector which selects (L+R),(L-R), (ECHOMIX) or (NORMAL).
D6		
D7	MICOUT SW	This is the ON/OFF switch for the Microphone signal.
D8	MIX VOL	There are 8 kinds of ATT. level which are from +3dB to -15dB,-∞dB(3dB step).
D9		
D10		
D11	FEED BACK V _{cc}	There are 8 kinds of ATT. level which are from -3dB to -15dB,-∞dB(2dB step).
D12		
D13		
D14	ADDRESS	D14=(L),D15=(H)DATA Load,the others cancel.
D15		



SINGLE CHIP SURROUND PROCESSOR

Description of Control

Delay Time Control

CONTROL DATA			DELAY TIME	The Cut Off Frequency of LPF
D0	D1	D2		
L	L	L	9.2msec	7.3kHz
H	L	L	15.4msec	
L	H	L	21.5msec	
H	H	L	28.7msec	
L	L	H	49.2msec	3.1kHz
H	L	H	98.3msec	
L	H	H	147.5msec	
H	H	H	196.6msec	

Input Selector Control

Control Data		INPUT SELECTOR
D3	D4	
L	L	I(L+R)
H	L	I(L-R)
L	H	I(MIC)
H	H	I(CLKOFF)

Output Selector Control

Control Data		OUTPUT SELECTOR
D5	D6	
L	L	O(L+R)
H	L	O(L-R)
L	H	O(ECHOMIX)
H	H	O(NORMAL)



M65849BFP

SINGLE CHIP SURROUND PROCESSOR

Microphone Output Switch Control

Control Data		MICOUT SWITCH
D7		
L		SW OFF
H		SW ON

Feedback volume Control

Control Data			FEEDBACK VOLUME
D11	D12	D13	
L	L	L	-3dB
H	L	L	-5dB
L	H	L	-7dB
H	H	L	-9dB
L	L	H	-11dB
H	L	H	-13dB
L	H	H	-15dB
H	H	H	-∞

Mix volume Control

Control Data			MIX VOLUME
D8	D9	D10	
L	L	L	+3dB
H	L	L	0dB
L	H	L	-3dB
H	H	L	-6dB
L	L	H	-9dB
H	L	H	-12dB
L	H	H	-15dB
H	H	H	-∞

Address Control

Control Data		ADDRESS
D14	D15	
L	L	DATA CANCEL
H	L	
L	H	DATA LOAD
H	H	DATA CANCEL

M65849BFP

SINGLE CHIP SURROUND PROCESSOR

Construction of Diagram

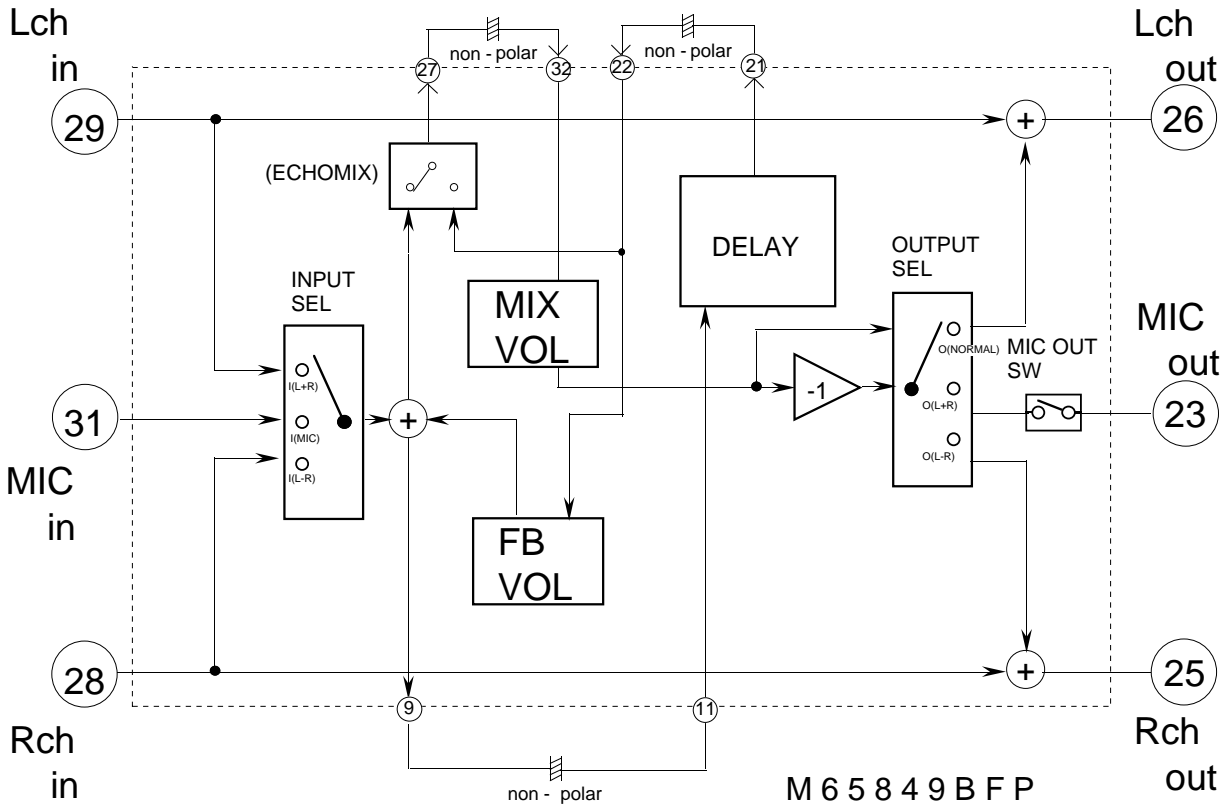

•DELAY TIME

There are 8 kinds of Delay Time which are from 9.6ms to 196.6ms.

•FEEDBACK VOLUME

There are 8 kinds of ATT. level which are from -3dB to -15dB, -∞dB.

•MIX VOLUME

There are 8 kinds of ATT. level which are from +3dB to -15dB, -∞dB.

•INPUT SELECTOR

This is the input selector which selects (CLOCKOFF),(L+R),(L-R)or (MIC).

•OUTPUT SELECTOR

This is the output selector which selects (L+R),(L-R),(ECHOMIX), (NORMAL).

•MIC SWITCH

This is the ON/OFF switch for the Microphone signal.



M65849BFP

SINGLE CHIP SURROUND PROCESSOR

The Power On Reset

When the IC is supplied Vcc, the reset circuit is on and after about 120ms (Vcc=5V C ^{*1} (24) =47μF) the reset circuit is off automatically.

The conditions are as follows.

D0	D1	D2	D3	D4	D5	D6	D7	D8	D9	D10	D11	D12	D13	D14	D15
L	L	L	L	H	L	L	L	H	H	H	H	H	H	L	H
9.2ms			I(L+R)	NORMAL	MICSW OFF	-		-		DATA LOAD					

*1 The Reset Time

The reset time depends on the external C of (24) pin and the time can be calculated as follows.

Ex.) The Reset Time (mS)=2.5 x c (mS)
In The Case Of c=47μF

The Reset Time=2.5 x 47=117.5 (mS)

Clock oscillator circuit

This IC incorporates a current control type clock oscillator circuit in it, thus providing circuit configuration just by connecting an Rc for current control pin ① (MCLKCONT).

Fully internal clock supply prevents occurrence of undesired radiation without affecting any external circuit.

The oscillator frequency fck is following.

$$f_{ck}=4\text{MHz}(R_c=22\text{k} \)$$

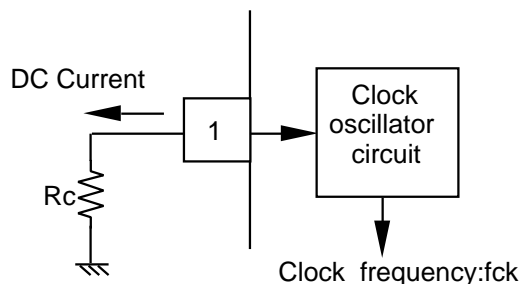

SINGLE CHIP SURROUND PROCESSOR

The Auto Muting

The auto muting is active upon the power-on and the changing delay time for rejecting the shock noise.

•Upon Power-on

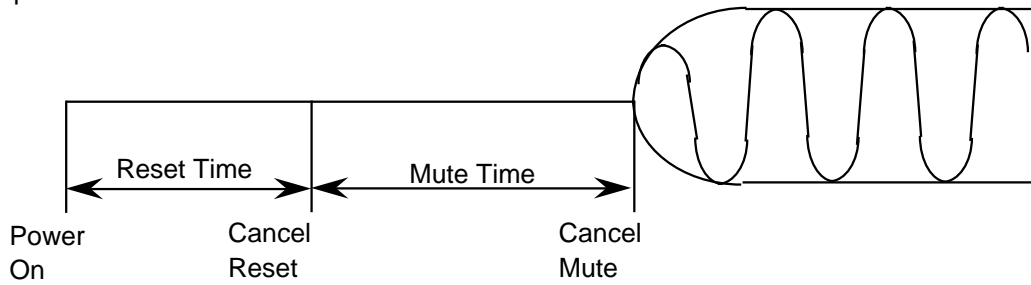

•Upon Changing Delay Time

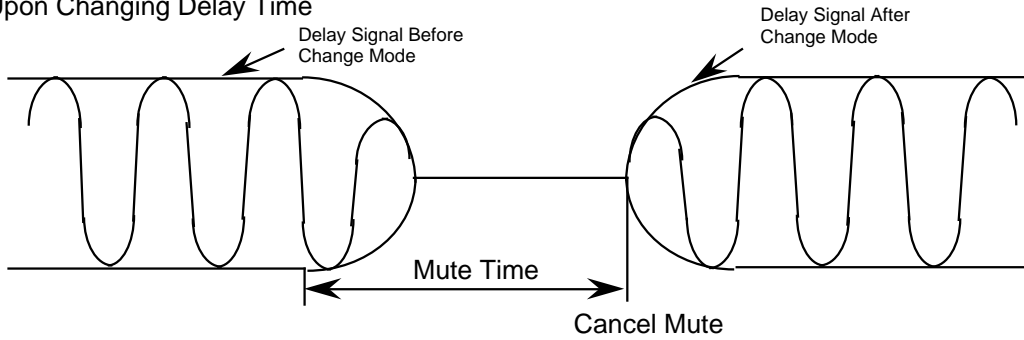

The Mute Time is set by Delay Time as follows.

DELAY TIME	MUTE TIME
	Typ.
9.2 ~ 196.6 ms	410 ms



M65849BFP

SINGLE CHIP SURROUND PROCESSOR

The LPF Of The Input & Output Stage Of The Digital Delay

The circuit of the LPF is as follows.

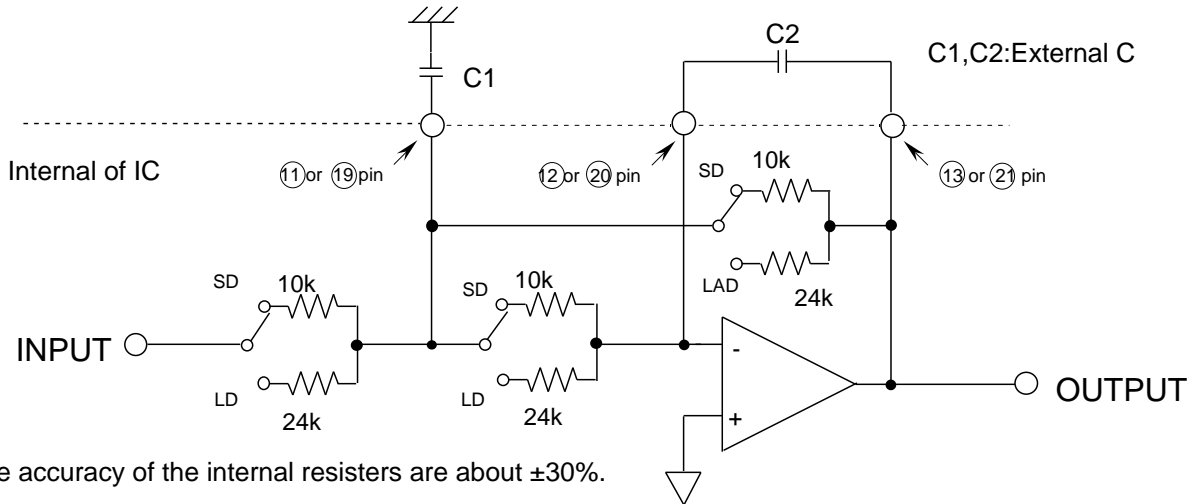

The accuracy of the internal resistors are about $\pm 30\%$.

DELAY TIME	S W
9.2 ~ 49.2 ms	SD (SHORT DELAY)
98.3 ~ 196.6 ms	LD (LONG DELAY)

* The cut off frequency is calculated by the following formulas.

•Surround

$$f_c = \frac{1}{2\pi \times 10k \times \sqrt{C1 \times C2}}$$

•Echo

$$f_c = \frac{1}{2\pi \times 24k \times \sqrt{C1 \times C2}}$$

The quality factor (Q) is as follows under the conditions of both Short Delay & Long Delay.

$$Q = \frac{1}{3} \sqrt{\frac{C1}{C2}}$$

At all the cut off frequency is decided by the external C.

We recommend $C1=0.0047\mu F$ and $C2=0.001\mu F$.

Under this condition, f_c and Q are as follows.

Surround $f_c=7.3kHz$ $Q=0.72$

Echo $f_c=3.1kHz$

* The Cut Off Frequency of LPF means the cut off frequency of the each stage (A/D & D/A) and doesn't mean the total cut off frequency.



M65849BFP

SINGLE CHIP SURROUND PROCESSOR

Absolute Maximum Ratings

No.	Parameter	Conditions	Ratings	Units
V _{cc}	Supply voltage		6.5	V
I _{cc}	Circuit Current		50	mA
P _d	Power dissipation		325	mW
T _{opr}	Operating Temperature		-20 ~ +75	°C
T _{stg}	Storage temperature		-40 ~ +125	°C

Recommended Operating Conditions

No.	Parameter	conditions	Limits			Units
			Min.	Typ.	Max.	
V _{cc}	Supply Voltage		4.5	5.0	5.5	V
V _{IH}	High Input Voltage	③ ④ ⑤	2.4	—	V _{cc}	V
V _{IL}	Low Input Voltage	③ ④ ⑤	0	—	0.8	V
f _{ck}	CLOCK Frequency		3	4	5	MHz

Thermal Derating

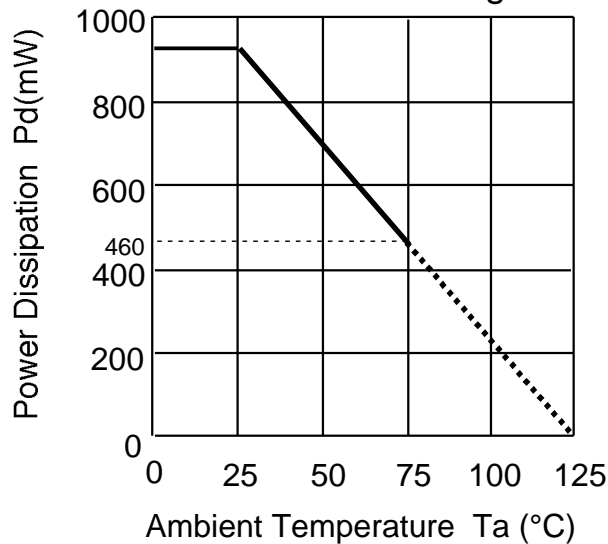



M65849BFP

SINGLE CHIP SURROUND PROCESSOR

Electrical Characteristics

(Ta=25°C, Vcc=5V, f=1kHz, Vi=200mVrms, fck=4MHz Unless Otherwise Noted)

	Symbol	Parameter	Conditions	Limits			Units
				Min.	Typ.	Max.	
Total	Icc	Circuit Current	No Signal	—	32	70	mA
Digital Delay	Td	Delay Time	Refer to Delay time Control	7.8	9.2	10.6	ms
				13.1	15.4	17.7	
				18.3	21.5	24.7	
				24.5	28.7	33.0	
				41.8	49.2	56.6	
				83.6	98.3	113.0	
				125.4	147.5	169.6	
				167.1	196.6	226.1	
	Gv	Voltage Gain		-3	0	3	dB
	THD	Output Distortion	Td = 9.2ms 30kHz LPF	—	0.3	0.6	%
			Td = 15.4ms 30kHz LPF	—	0.3	0.6	
			Td = 21.5ms 30kHz LPF	—	0.3	0.6	
			Td = 28.7ms 30kHz LPF	—	0.5	1.0	
			Td = 49.2ms 30kHz LPF	—	0.7	1.4	
			Td = 98.3ms 30kHz LPF	—	1.0	2.0	
Td = 147.5ms 30kHz LPF			—	1.5	3.0		
Td = 196.6ms 30kHz LPF			—	2.0	4.0		
Vo max	Maximum Output Voltage	30kHz LPF THD = 10 %	0.7	1.0	—	Vrms	
No	Output Noise Voltage	Td = 9.2ms Rg=620 Vi = 0mVrms JIS-A	—	-92	-80	dBV	
		Td = 15.4ms Rg=620 Vi = 0mVrms JIS-A	—	-92	-80		
		Td = 21.5ms Rg=620 Vi = 0mVrms JIS-A	—	-92	-80		
		Td = 28.7ms Rg=620 Vi = 0mVrms JIS-A	—	-90	-75		
		Td = 49.2ms Rg=620 Vi = 0mVrms JIS-A	—	-90	-75		
		Td = 98.3ms Rg=620 Vi = 0mVrms JIS-A	—	-87	-72		
		Td = 147.5ms Rg=620 Vi = 0mVrms JIS-A	—	-82	-70		
		Td = 196.6ms Rg=620 Vi = 0mVrms JIS-A	—	-77	-62		

M65849BFP



SINGLE CHIP SURROUND PROCESSOR

(Ta=25°C, Vcc=5V, f=1kHz, Vi=200mVrms, fck=4MHz Unless Otherwise Noted)

	No.	Parameter	Conditions	Limits			Units
				Min.	Typ.	Max.	
MIX VOLUME FEEDBACK VOLUME	Gv	Voltage Gain	Volume max	FB VOL -6 Mix VOL 0	-3 3	0 6	dB
	ATTMAX	Maximum ATT.	Volume min JIS-A	—	-70	-60	
	THD	Output Distortion	Volume max 30kHz LPF RL=47k	—	0.15	0.30	%
	Vomax	Maximum Output Voltage	Volume max 30kHz LPF THD=10% RL=47k	1.1	1.4	—	Vrms
	No	Output Noise Voltage	Volume max JIS-A Rg=620	—	-98	-90	dBV
	Voff	Offset Voltage	Mix Volume +3dB-0dB voltage (3dB,0dB)	—	—	±1.6	mV
LINE AMPLIFIER	Gv	Voltage Gain		-3	0	3	dB
	THD	Output Distortion	30kHz LPF	—	0.01	0.03	%
	Vomax	Maximum Output Voltage	30kHz LPF RL = 10k THD=10 %	1.2	1.8	—	Vrms
	No	Output Noise Voltage	DELAYOFF MODE JIS-A Rg=620	—	-98	-90	dBV
	CS	Channel Separation	DMIXSW OFF LchIN RchOUT f=400Hz JIS-A	—	-90	-60	dB
	Zi	Input Impedance		21	30	—	k



SINGLE CHIP SURROUND PROCESSOR

The Application Example

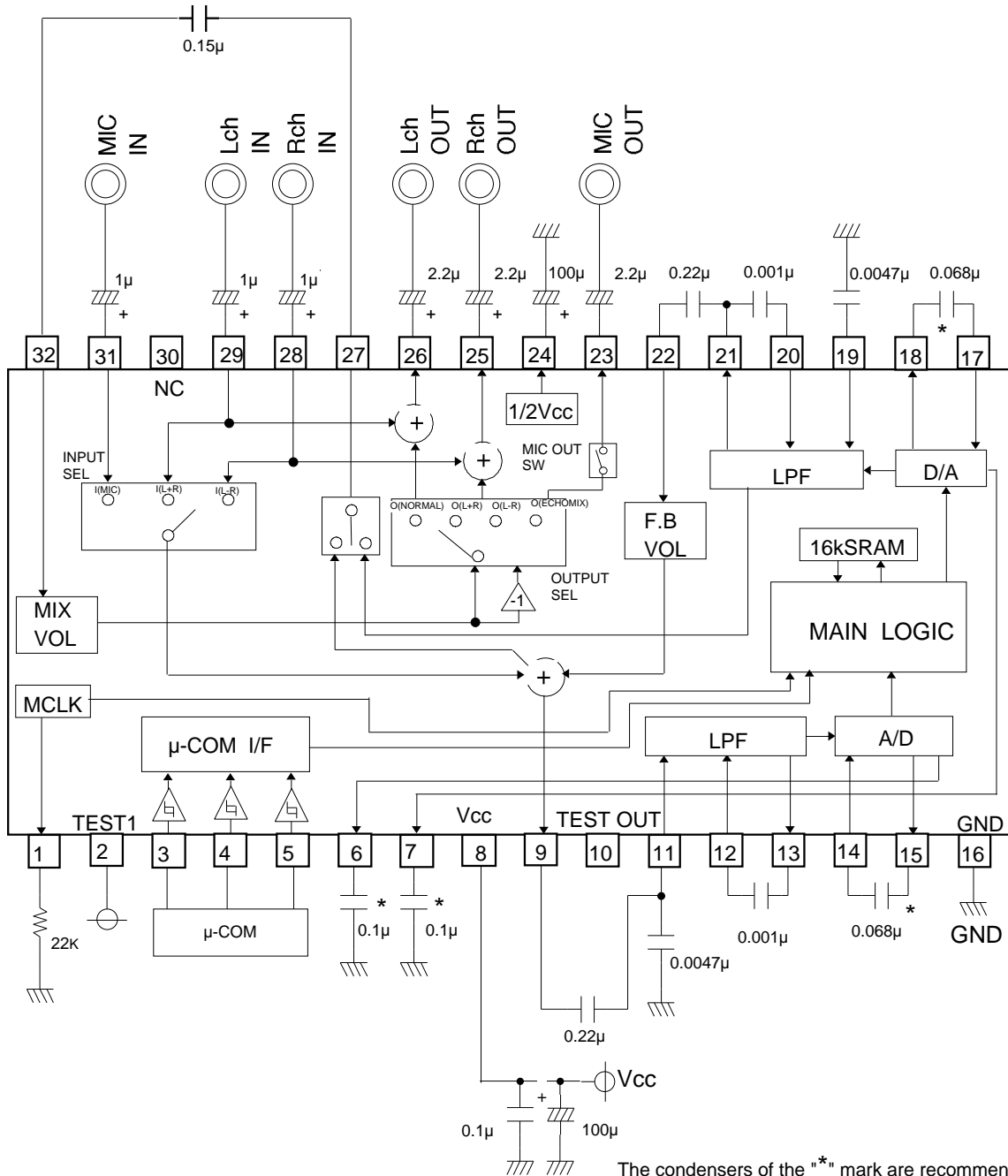

The condensers of the "*" mark are recommended less than ±5% relative accuracy.

Units: Resistor:
Condenser:F