



LC87F72C8A

8-Bit Single Chip Microcontroller with 128 KB Flash Memory and 2048-Byte RAM On Chip

Preliminary

Overview

The LC87F72C8A is an 8 bit single chip microcontroller with the following on-chip functional blocks :

- CPU: operable at a minimum bus cycle time of 100 ns
- 128K bytes flash ROM (on-board rewritable)
- On-chip RAM: 2048 bytes
- LCD controller / driver
- 16 bit timer / counter (can be divided into two 8 bit timers)
- 16 bit timer / PWM (can be divided into two 8 bit timers)
- Timer for use as date / time clock
- Synchronous serial I/O port (with automatic block transmit / receive function)
- Asynchronous / synchronous serial I/O port
- 12-channel \times 8-bit AD converter
- Small signal detector
- 14-source 10-vectored interrupt system

All of the above functions are fabricated on a single chip.

Features

(1) Flash ROM

- Single 5V power supply, on-board writable
- Block erase in 128 byte units
- 131072 \times bits (LC87F72C8A)

(2) Random Access Memory (RAM): 2048 \times 9 bits (LC87F72C8A)

*Flash memory products are manufactured and sold by SANYO Electric Co., Ltd. under license from Silicon Storage Technology, Inc. (USA).

■ Any and all SANYO products described or contained herein do not have specifications that can handle applications that require extremely high levels of reliability, such as life-support systems, aircraft's control systems, or other applications whose failure can be reasonably expected to result in serious physical and/or material damage. Consult with your SANYO representative nearest you before using any SANYO products described or contained herein in such applications.

■ SANYO assumes no responsibility for equipment failures that result from using products at values that exceed, even momentarily, rated values (such as maximum ratings, operating condition ranges, or other parameters) listed in products specifications of any and all SANYO products described or contained herein.

SANYO Electric Co.,Ltd. Semiconductor Company

TOKYO OFFICE Tokyo Bldg., 1-10, 1 Chome, Ueno, Taito-ku, TOKYO, 110-8534 JAPAN

(3) Minimum Bus Cycle Time: 100 ns (10 MHz)

Note: The bus cycle time indicates ROM read time.

(4) Minimum Instruction Cycle Time: 300 ns (10MHz)

(5) Ports

- Input/output ports

Data direction programmable for each bit individually : 26 (P1n, P30-P35, P70-P73, P8n)

Data direction programmable in nibble units : 8 (P0n)

(When N-channel open drain output is selected, data can be input in bit units.)

- Input ports : 2 (XT1,XT2)

- LCD ports

Segment output : 48 (S00-S47)

Common output : 4 (COM0-COM3)

Bias terminals for LCD driver 3 (V1-V3)

Other functions

Input/output ports : 48(PAn,PBn,PCn,PDn,PEn,PFn)

Input ports : 7 (PLn)

- Oscillator pins : 2 (CF1,CF2)

- Reset pin : 1 (RES)

- Power supply : 6 (VSS1-3,VDD1-3)

(6) LCD controller

- Seven display modes are available (static, 1/2, 1/3, 1/4 duty × 1/2, 1/3 bias)

- Segment output and common output can be switched to general purpose input/output ports.

(7) Small signal detection (MIC signals etc)

- Counts pulses with the level which is greater than a preset value

- 2 bit counter

(8) Timers

- Timer 0: 16 bit timer / counter with capture register

Mode 0: 2 channel 8-bit timer with programmable 8 bit prescaler and 8 bit capture register

Mode 1: 8 bit timer with 8 bit programmable prescaler and 8 bit capture register + 8 bit

Counter with 8-bit capture register

Mode 2: 16 bit timer with 8 bit programmable prescaler and 16 bit capture register

Mode 3: 16 bit counter with 16 bit capture register

- Timer 1: PWM / 16 bit timer with toggle output function

Mode 0: 2 channel 8 bit timer (with toggle output)

Mode 1: 2 channel 8 bit PWM

Mode 2: 16 bit timer (with toggle output) Toggle output from lower 8 bits is also possible.

Mode 3: 16 bit timer (with toggle output) Lower order 8 bits can be used as PWM.

- Base Timer

1) The clock signal can be selected from any of the following :

Sub-clock (32.768kHz crystal oscillator), system clock, and prescaler output from timer 0

2) Interrupts of five different time intervals are possible.

(9) Serial-interface

- SIO 0: 8 bit synchronous serial interface
 - 1) LSB first / MSB first is selectable
 - 2) Internal 8 bit baud-rate generator (fastest clock period 4 / 3 Tcyc)
 - 3) Consecutive automatic data communication (1-256 bits)
- SIO 1: 8 bit asynchronous / synchronous serial interface
 - Mode 0: Synchronous 8 bit serial IO (2-wire or 3-wire, transmit clock 2–512 Tcyc)
 - Mode 1: Asynchronous serial IO (half duplex, 8 data bits, 1 stop bit, baud rate 8–2048Tcyc)
 - Mode 2: Bus mode 1 (start bit, 8 data bits, transmit clock 2–512 Tcyc)
 - Mode 3: Bus mode 2 (start detection, 8 data bits, stop detection)

(10) AD converter

- 8 bits × 12 channels

(11) Remote control receiver circuit (connected to P73 / INT3 / T0IN terminal)

- Noise rejection function (noise rejection filter's time constant can be selected from 1 / 32 / 128 Tcyc)

(12) Watchdog timer

- The watching time period is determined by an external RC.
- Watchdog timer can produce interrupt or system reset

(13) Interrupts: 14 sources, 10 vectors

- 1) Three priority (low, high and highest) multiple interrupts are supported. During interrupt handling, an equal or lower priority interrupt request is postponed.
- 2) If interrupt requests to two or more vector addresses occur at once, the higher priority interrupt takes precedence. In the case of equal priority levels, the vector with the lowest address takes precedence.

No.	Vector	Selectable Level	Interrupt signal
1	00003H	X or L	INT0
2	0000BH	X or L	INT1
3	00013H	H or L	INT2/T0L
4	0001BH	H or L	INT3/Base timer
5	00023H	H or L	T0H
6	0002BH	H or L	T1L/T1H
7	00033H	H or L	SIO0
8	0003BH	H or L	SIO1
9	00043H	H or L	ADC/MIC
10	0004BH	H or L	Port 0

- Priority Level: X>H>L
- For equal priority levels, vector with lowest address takes precedence.

(14) Subroutine stack levels: 1024 levels max. Stack is located in RAM.

(15) Multiplication and division

- 16 bit × 8 bit (executed in 5 cycles)
- 24 bit × 16 bit (12 cycles)
- 16 bit ÷ 8 bit (8 cycles)
- 24 bit ÷ 16 bit (12 cycles)

(16) Oscillation circuits

- On-chip RC oscillation for system clock use.
- CF oscillation for system clock use. (Rf built in, Rd external)
- Crystal oscillation low speed system clock use. (Rf built in, Rd external)

(17) Standby function

- HALT mode

HALT mode is used to reduce power consumption. During the HALT mode, program execution is stopped but peripheral circuits keep operating (some parts of serial transfer operation stop.)

- 1) Oscillation circuits are not stopped automatically.
- 2) Released by the system reset or interrupts.

-HOLD mode

HOLD mode is used to reduce power consumption. Program execution and peripheral circuits are stopped.

- 1) CF, RC and crystal oscillation circuits stop automatically.
- 2) Released by any of the following conditions.
 1. Low level input to the reset pin
 2. Specified level input to one of INT0, INT1, INT2
 3. Port 0 interrupt

-X'tal HOLD mode

X'tal HOLD mode is used to reduce power consumption. Program execution is stopped.

All peripheral circuits except the base timer are stopped.

- 1) CF and RC oscillation circuits stop automatically.
- 2) Crystal oscillator operation is kept in its state at HOLD mode inception.
- 3) Released by any of the following conditions
 1. Low level input to the reset pin
 2. Specified level input to one of INT0, INT1, INT2
 3. Port 0 interrupt
 4. Base-timer interrupt

(18) Package

- QIP100E
- SQFP100

(19) Development tools

- Evaluation chip: LC876096
- Emulator: EVA62S + ECB876500 (Evaluation chip board) + SUB877200 + POD100QFP or POD100SQFP (Type B)

(20) Same package and pin assignment as mask ROM version.

- 1) LC877200 series options can be set using flash ROM data. Thus the board used for mass production can be used for debugging and evaluation without modifications.
- 2) If the program for the mask ROM version is used, the usable ROM/RAM capacity is the same as the mask ROM version.

LC87F72C8A

Pin Assignment

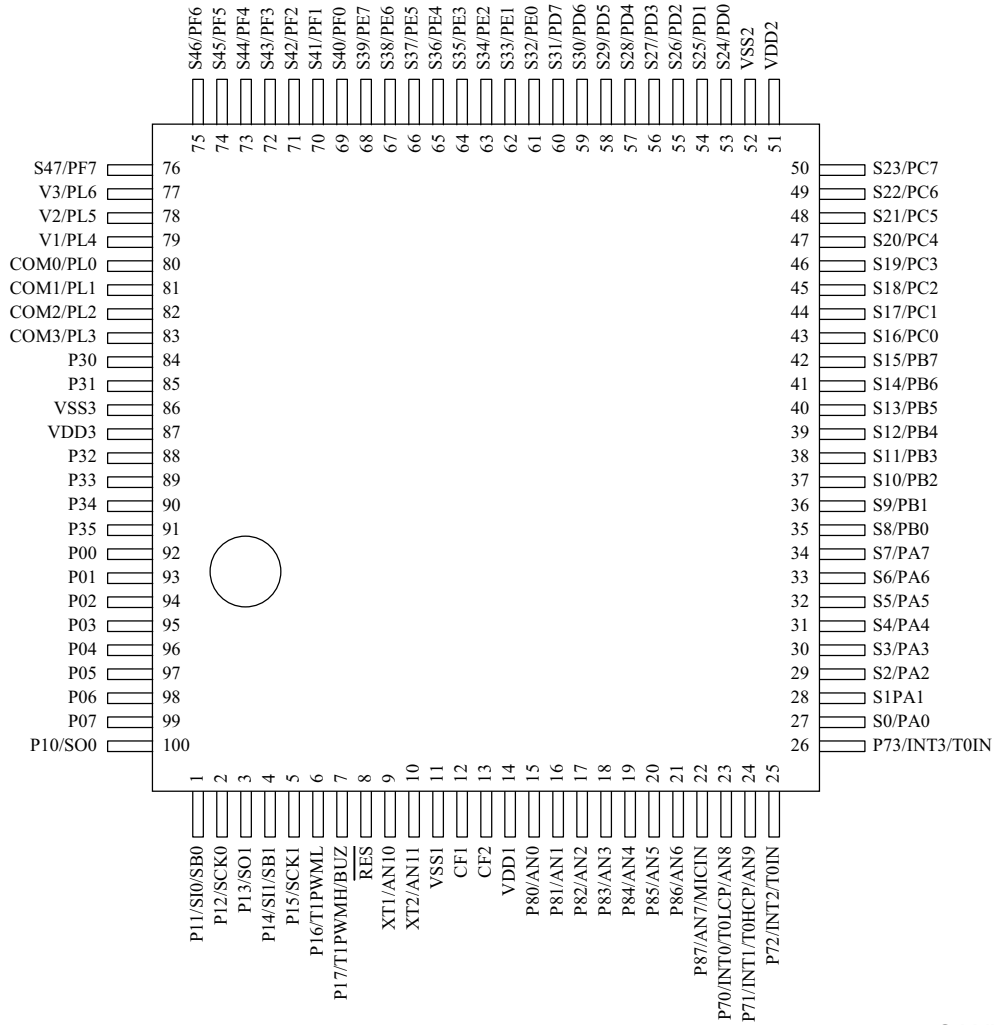

SANYO : SQFP-100

Package Dimension

(unit : mm)

3181B

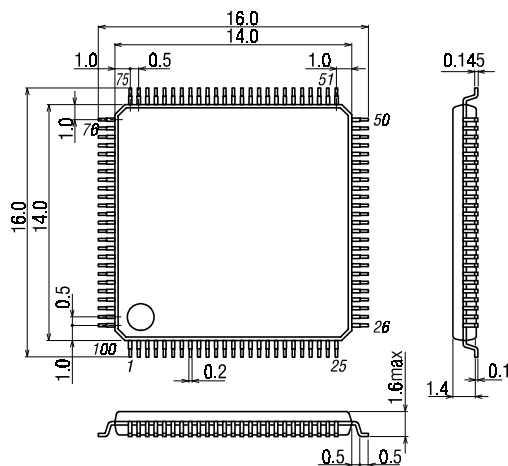

SANYO : SQFP-100

System Block Diagram

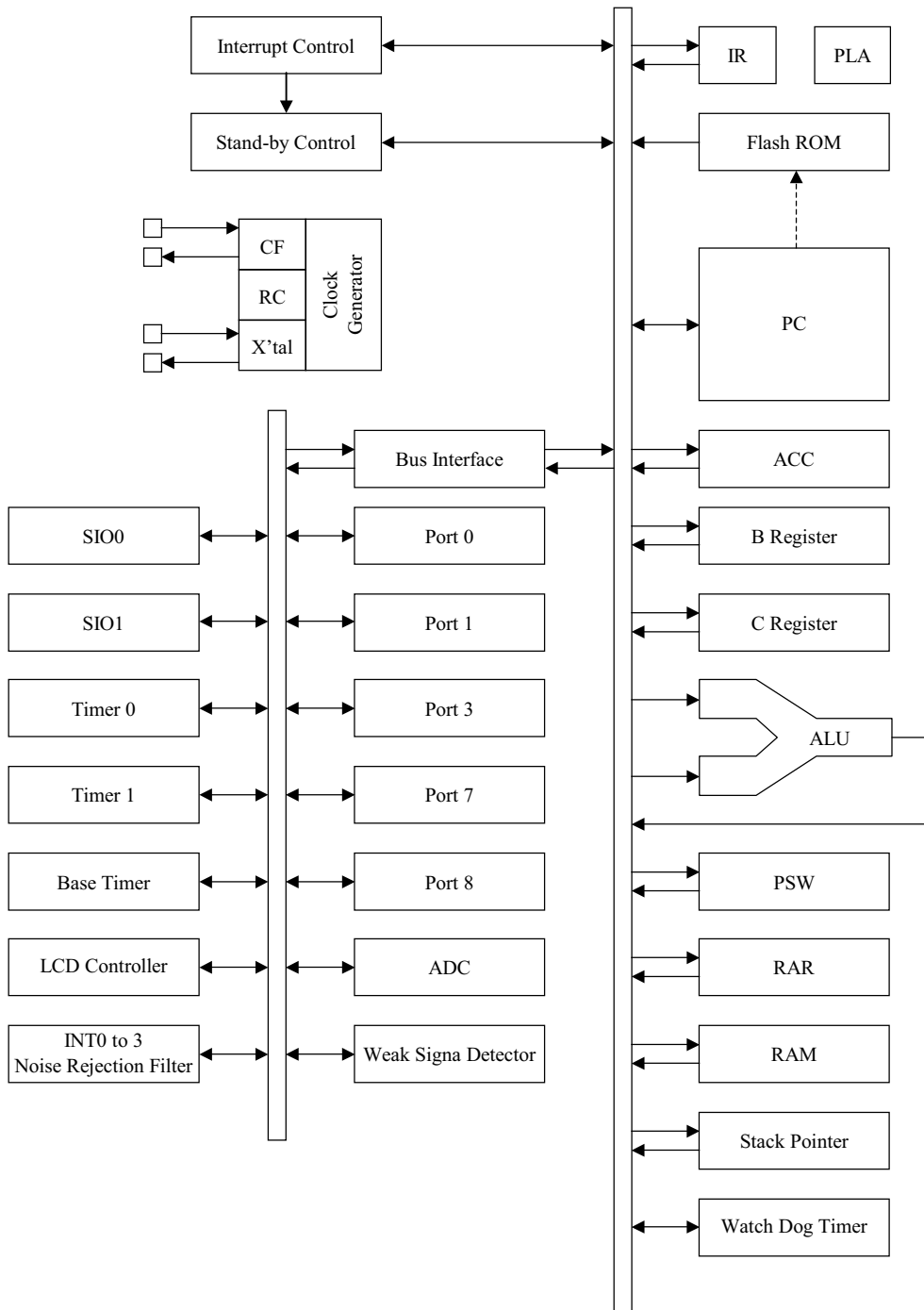

Pin Assignment

Pin name	I/O	Function	Option																														
VSS1 VSS2 VSS3	-	<ul style="list-style-type: none"> Power supply (-) 	No																														
VDD1 VDD2 VDD3	-	<ul style="list-style-type: none"> Power supply (+) 	No																														
PORT0 P00 to P07	I/O	<ul style="list-style-type: none"> 8bit input/output port Data direction programmable in nibble units Use of pull-up resistor can be specified in nibble units Input for HOLD release Input for port 0 interrupt 	Yes																														
PORT1 P10 to P17	I/O	<ul style="list-style-type: none"> 8bit input/output port Data direction programmable for each bit Use of pull-up resistor can be specified for each bit individually Other pin functions <ul style="list-style-type: none"> P10 SIO0 data output P11 SIO0 data input or bus input/output P12 SIO0 clock input/output P13 SIO1 data output P14 SIO1 data input or bus input/output P15 SIO1 clock input/output P16: Timer 1 PWML output P17: Timer 1 PWMH output/Buzzer output 	Yes																														
PORT3 P30 to P35	I/O	<ul style="list-style-type: none"> 6bit Input/output port Data direction can be specified for each bit Use of pull-up resistor can be specified for each bit individually 	Yes																														
PORT7 P70 to P73	I/O	<ul style="list-style-type: none"> 4bit Input/output port Data direction can be specified for each bit Use of pull-up resistor can be specified for each bit individually Other functions <ul style="list-style-type: none"> P70: INT0 input/HOLD release input/Timer0L capture input/output for watchdog timer P71: INT1 input/HOLD release input/Timer0H capture input P72: INT2 input/HOLD release input/timer 0 event input/Timer0L capture input P73: INT3 input(noise rejection filter attached)/timer 0 event input/Timer0H capture input AD input port: AN8(P70), AN9(P71) Interrupt detection selection <table border="1" style="margin-left: 20px;"> <thead> <tr> <th></th> <th>Rising</th> <th>Falling</th> <th>Rising and falling</th> <th>H level</th> <th>L level</th> </tr> </thead> <tbody> <tr> <td>INT0</td> <td>Yes</td> <td>Yes</td> <td>No</td> <td>Yes</td> <td>Yes</td> </tr> <tr> <td>INT1</td> <td>Yes</td> <td>Yes</td> <td>No</td> <td>Yes</td> <td>Yes</td> </tr> <tr> <td>INT2</td> <td>Yes</td> <td>Yes</td> <td>Yes</td> <td>No</td> <td>No</td> </tr> <tr> <td>INT3</td> <td>Yes</td> <td>Yes</td> <td>Yes</td> <td>No</td> <td>No</td> </tr> </tbody> </table> 		Rising	Falling	Rising and falling	H level	L level	INT0	Yes	Yes	No	Yes	Yes	INT1	Yes	Yes	No	Yes	Yes	INT2	Yes	Yes	Yes	No	No	INT3	Yes	Yes	Yes	No	No	No
	Rising	Falling	Rising and falling	H level	L level																												
INT0	Yes	Yes	No	Yes	Yes																												
INT1	Yes	Yes	No	Yes	Yes																												
INT2	Yes	Yes	Yes	No	No																												
INT3	Yes	Yes	Yes	No	No																												

LC87F72C8A

Pin name	I/O	Function description	Option
PORT8 P80 to P87	I/O	<ul style="list-style-type: none"> • 8bit Input/output port • Input/output can be specified for each bit individually • Other functions: AD input port: AN0 to AN7 Small signal detector input port: MICIN(P87) 	No
S0/PA0 to S7/PA7	I/O	<ul style="list-style-type: none"> • Segment output for LCD • Can be used as general purpose input/output port (PA) 	No
S8/PB0 to S15/PB7	I/O	<ul style="list-style-type: none"> • Segment output for LCD • Can be used as general purpose input/output port (PB) 	No
S16/PC0 to S23/PC7	I/O	<ul style="list-style-type: none"> • Segment output for LCD • Can be used as general purpose input/output port (PC) 	No
S24 /PD0to S31/PD7	I/O	<ul style="list-style-type: none"> • Segment output for LCD • Can be used as general purpose input/output port (PD) 	No
S32/PE0 to S39/PE7	I/O	<ul style="list-style-type: none"> • Segment output for LCD • Can be used as general purpose input/output port (PE) 	No
S40/PF0 to S47/PF7	I/O	<ul style="list-style-type: none"> • Segment output for LCD • Can be used as general purpose input/output port (PF) 	No
COM0/PL0 to COM3/PL3	I/O	<ul style="list-style-type: none"> • Common output for LCD • Can be used as general purpose input port (PL) 	No
V1/PL4 to V3/PL6	I/O	<ul style="list-style-type: none"> • LCD output bias power supply • Can be used as general purpose input port (PL) 	No
$\overline{\text{RES}}$	I	Reset terminal	No
XT1	I	<ul style="list-style-type: none"> • Input for 32.768kHz crystal oscillation • Other functions: General purpose input port AD input port: AN10 • When not in use, connect to VDD1 	No
XT2	I/O	<ul style="list-style-type: none"> • Output for 32.768kHz crystal oscillation • Other functions: General purpose input port AD input port: AN11 • When not in use, set to oscillation mode and leave open 	No
CF1	I	Input terminal for ceramic oscillator	No
CF2	O	Output terminal for ceramic oscillator	No

Port Configuration

Port form and pull-up resistor options are shown in the following table.

Port status can be read even when port is set to output mode.

Terminal	Option applies to:	Options	Output Form	Pull-up resistor
P00 to P07	each bit	1	CMOS	Programmable (Note 1)
		2	Nch-open drain	None
P10 to P17	each bit	1	CMOS	Programmable
		2	Nch-open drain	Programmable
P30 to P35	each bit	1	CMOS	Programmable
		2	Nch-open drain	None
P70	–	None	Nch-open drain	Programmable
P71 to P73	–	None	CMOS	Programmable
P80 to P87	–	None	Nch-open drain	None
S0/PA0 to S47/PF7	–	None	CMOS	Programmable
COM0/PL0 to COM3/PL3	–	None	Input only	None
V1/PL4 to V3/PL6	–	None	Input only	None
XT1	–	None	Input only	None
XT2	–	None	Output for 32.768kHz crystal oscillation	None

Note 1 Attachment of Port0 programmable pull-up resistors is controllable in nibble units (P00-03, P04-07).

* Note 1: Connect as follows to reduce noise on VDD.

VSS1, VSS2 and VSS3 must be connected together and grounded.

*Note 2 : The power supply for the internal memory is VDD1 but it uses the VDD2 as the power supply for ports. When the VDD2 is not backed up, the port level does not become “H” even if the port latch is in the “H” level. Therefore, when the VDD2 is not backed up and the port latch is “H” level, the port level is unstable in the HOLD mode, and the back up time becomes shorter because the through current runs from VDD to GND in the input buffer. If VDD2 is not backed up, output “L” by the program or pull the port to “L” by the external circuit in the HOLD mode so that the port level becomes “L” level and unnecessary current consumption is prevented.

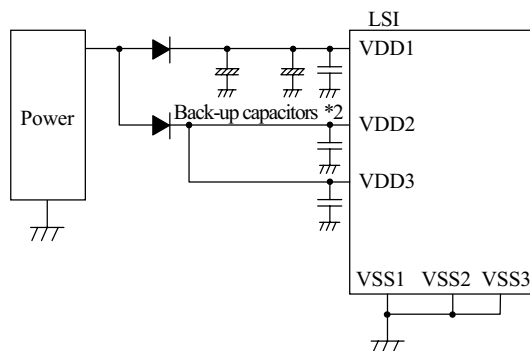

LC87F72C8A

1. Absolute Maximum Ratings at Ta=25°C and VSS1=VSS2=VSS3=0V

Parameter	Symbol	Pins	Conditions	Ratings			unit	
				VDD[V]	min.	typ.		max.
Supply voltage	VDDMAX	VDD1,VDD2,VDD3	VDD1=VDD2 =VDD3		-0.3		+6.5	V
Supply voltage for LCD	VLCD	V1/PL4, V2/PL5, V3/PL6	VDD1=VDD2 =VDD3		-0.3		VDD	
Input voltage	VI	Port L XT1,XT2,CF1, \overline{RES}			-0.3		VDD+0.3	
Input/Output voltage	VI0(1)	• Port0, 1, 3, 7, 8 • Port A, B, C, D, E, F			-0.3		VDD+0.3	
High level output current	Peak output current	IOPH(1)	Port 0, 1, 3	• CMOS output selected • Current at each pin		-10		mA
		IOPH(2)	Port 71,72,73	Current at each pin		-3		
		IOPH(3)	Port A, B, C, D, E, F	Current at each pin		-5		
	Total output current	Σ IOAH(1)	Port 0, 1, 32, 33, 34, 35	Total of all pins		-40		
		Σ IOAH(2)	Port 30, 31	Total of all pins		-10		
		Σ IOAH(3)	Port 7	Total of all pins		-5		
		Σ IOAH(4)	Port A, B, C	Total of all pins		-25		
Σ IOAH(5)	Port D, E, F	Total of all pins		-25				
Low level output current	Peak output current	IOPL(1)	Port 0, 1, 32-35	Current at each pin			20	
		IOPL(2)	Port 30, 31	Current at each pin			30	
		IOPL(3)	Port 7,8	Current at each pin			5	
		IOPL(4)	Port A, B,C, D, E, F	Current at each pin			15	
	Total output current	Σ IOAL(1)	Port 0, 1, 32, 33, 34, 35	Total of all pins			60	
		Σ IOAL(2)	Port 30, 31	Total of all pins			60	
		Σ IOAL(3)	Port 7,8	Total of all pins			20	
Σ IOAL(4)	Port A,B,C	Total of all pins			40			
Σ IOAL(5)	Port D, E, F	Total of all pins			40			
Maximum power consumption	Pdmax	QIP100E	Ta = -20 to +70°C				500	mW
		SQFP100					400	
Operating temperature range	Topg				-20		70	°C
Storage temperature range	Tstg				-55		125	

LC87F72C8A

2. Recommended Operating Range at Ta=-20°C to +70°C, VSS1=VSS2=VSS3=0V

Parameter	Symbol	Pins	Conditions	Ratings			unit	
				VDD[V]	min.	typ.		max.
Operating supply voltage range	VDD(1)	VDD1=VDD2=VDD3	0.294μs ≤ tCYC ≤ 200μs		4.5		5.5	V
	VDD(2)		0.735μs ≤ tCYC ≤ 200μs		3.0		5.5	
Supply voltage range in Hold mode	VHD	VDD1	Keep RAM and register data in HOLD mode.		2.0		5.5	
Input high voltage	VIH(1)	• Port 0, 3, 8 • Port A,B,C,D,E,F,L	Output disable	3.0–5.5	0.3VDD +0.7		VDD	
	VIH(2)	• Port 1 • Port 71,72,73 • P70 port input/interrupt	Output disable	3.0–5.5	0.3VDD +0.7		VDD	
	VIH(3)	P87 small signal input	Output disable	3.0–5.5	0.75VDD		VDD	
	VIH(4)	Port 70 Watchdog timer	Output disable	3.0–5.5	0.9VDD		VDD	
	VIH(5)	XT1, XT2, CF1, RES		3.0–5.5	0.75VDD		VDD	
Input low voltage	VIL(1)	• Port 0, 3, 8 • Port A,B,C,D,E,F,L	Output disable	3.0–5.5	VSS		0.15VDD +0.4	
	VIL(2)	• Port 1 • Port 71,72,73 • P70 port input/interrupt	Output disable	3.0–5.5	VSS		0.1VDD +0.4	
	VIL(3)	Port 87 small signal input	Output disable	3.0–5.5	VSS		0.25VDD	
	VIL(4)	Port 70 Watchdog timer	Output disable	3.0–5.5	VSS		0.8VDD -1.0	
	VIL(5)	XT1,XT2,CF1, RES		3.0–5.5	VSS		0.25VDD	
Operation cycle time	tCYC			4.5–5.5	0.294		200	μs
				3.0–5.5	0.735		200	
External system clock frequency	FEXCF(1)	CF1	• CF2 open • system clock divider :1/1	4.5–5.5	0.1		10	MHz
			• external clock DUTY = 50 ± 5%	3.0–5.5	0.1		4	
			• CF2 open • system clock divider :1/2	4.5–5.5	0.2		20	
				3.0–5.5	0.2		8	

Continued/

LC87F72C8A

Parameter	Symbol	Pins	Conditions	Ratings			unit	
				VDD[V]	min.	typ.		max.
Oscillation frequency range (Note 1)	FmCF(1)	CF1, CF2	10MHz ceramic resonator oscillation Refer to figure 1	4.5–5.5		10		MHz
	FmCF(2)	CF1, CF2	4MHz ceramic resonator oscillation Refer to figure 1	3.0–5.5		4		
	FmRC		RC oscillation	3.0–5.5	0.3	1.0	2.0	
	FsX'tal	XT1, XT2	32.768kHz crystal resonator oscillation Refer to figure 2	3.0–5.5		32.768		kHz

(Note 1) The parts value of oscillation circuit is shown in table 1 and table 2.

LC87F72C8A

3. Electrical Characteristics at Ta=-20°C to +70°C, VSS1=VSS2=VSS3=0V

Parameter	Symbol	Pins	Conditions	Ratings			unit	
				VDD[V]	min.	typ.		max.
High level input current	IIH(1)	• Port 0,1,3,7,8 • Port A,B,C,D,E,F,L	• Output disabled • Pull-up resistor OFF. • VIN=VDD (including OFF state leak current of the output Tr.)	3.0-5.5			1	μA
	IIH(2)	\overline{RES}	VIN=VDD	3.0-5.5			1	
	IIH(3)	XT1,XT2	When configured as an input port VIN=VDD	3.0-5.5			1	
	IIH(4)	CF1	VIN=VDD	3.0-5.5			15	
	IIH(5)	P87/AN7/MICIN small signal input	VIN=V _{BIS} +0.5V (V _{BIS} : Bias voltage)	3.0-5.5	4.2	8.5	15	
Low level input current	IIL(1)	• Port 0,1,3,7,8 • Port A,B,C,D,E,F,L	• Output disabled • Pull-up resistor OFF. • VIN=VSS (including OFF state leak current of the output Tr.)	3.0-5.5	-1			
	IIL(2)	\overline{RES}	VIN=VSS	3.0-5.5	-1			
	IIL(3)	XT1,XT2	When configured as an input port VIN=VSS	3.0-5.5	-1			
	IIL(4)	CF1	VIN=VSS	3.0-5.5	-15			
	IIL(5)	P87/AN7/MICIN small signal input	VIN=V _{BIS} -0.5V (V _{BIS} : Bias voltage)	3.0-5.5	-15	-8.5	-4.2	
High level output voltage	VOH(1)	Port 0,1,3: CMOS output option	IOH=-1.0mA	4.5-5.5	VDD-1			V
	VOH(2)		IOH=-0.1mA	3.0-5.5	VDD-0.5			
	VOH(3)	Port 7	IOH=-0.4mA	3.0-5.5	VDD-1			
	VOH(4)	Port A,B,C,D,E,F	IOH=-1.0mA	4.5-5.5	VDD-1			
	VOH(5)		IOH=-0.1mA	3.0-5.5	VDD-0.5			
Low level output voltage	VOL(1)	Port 0,1,3	IOL=10mA	4.5-5.5			1.5	
	VOL(2)		IOL=1.6mA	3.0-5.5			0.4	
	VOL(3)	Port 30,31	IOL=30mA	4.5-5.5			1.5	
	VOL(4)	Port 7,8	IOL=1mA	4.5-5.5			0.4	
	VOL(5)		IOL=0.5mA	3.0-5.5			0.4	
	VOL(6)	Port A,B,C,D,E,F	IOL=8mA	4.5-5.5			1.5	
	VOL(7)		IOL=1.4mA	3.0-5.5			0.4	
LCD output voltage regulation	VODLS	S0-S47	I0=0mA VLCD, 2/3VLCD, 1/3VLCD level output Refer to figure 8	3.0-5.5	0		± 0.2	
	VODLC	COM0-COM3	I0=0mA VLCD, 2/3VLCD, 1/2VLCD 1/3VLCD level output Refer to figure 8	3.0-5.5	0		± 0.2	

Continued/

LC87F72C8A

Parameter	Symbol	Pins	Conditions	Ratings			unit	
				VDD[V]	min.	typ.		max.
LCD bias resistor	RLCD(1)	Resistance per one bias resistor	Refer to figure 8	3.0–5.5		60		kΩ
	RLCD(2)	<ul style="list-style-type: none"> • Resistance per one bias resistor • 1/2R mode 	Refer to figure 8	3.0–5.5		30		
Resistance of pull-up MOS Tr.	Rpu	<ul style="list-style-type: none"> • Port 0,1,3,7 • Port A,B,C,D,E,F 	VOH=0.9VDD	4.5–5.5	15	40	70	kΩ
				3.0–5.5	25	70	150	
Hysteresis voltage	VHIS(1)	<ul style="list-style-type: none"> • Port 1,7 • $\overline{\text{RES}}$ 		3.0–5.5		0.1VDD		V
	VHIS(2)	Port 87 small signal input		3.0–5.5		0.1VDD		
Pin capacitance	CP	All pins	<ul style="list-style-type: none"> • All Other Terminals Connected To VSS. • $F=1\text{MHz}$ • $T_a=25^\circ\text{C}$ 	3.0–5.5		10		pF
Input sensitivity	Vsen	Port 87 small signal input		3.0–5.5	0.12VDD			Vpp

4. Serial Input/Output Characteristics at Ta=-20°C to +70°C, VSS1=VSS2=VSS3=0V

Parameter	Symbol	Pins	Conditions	Ratings			unit				
				VDD[V]	min.	typ.		max.			
Serial clock	Input clock	Cycle time	tSCK(1)	SCK0(P12)	Refer to figure 6	3.0-5.5	4/3		tCYC		
		Low level pulse width	tSCKL(1)				2/3				
			tSCKLA(1)				2/3				
		High level pulse width	tSCKH(1)				2/3				
			tSCKHA(1)				3				
		Output clock	Cycle time				tSCK(2)	SCK1(P15)		Refer to figure 6	3.0-5.5
	Low level pulse width		tSCKL(2)	1							
			tSCKH(2)	1							
	Output clock	Input clock	Cycle time	tSCK(3)	SCK0(P12)	• CMOS output • Refer to figure 6	3.0-5.5	4/3	tSCK		
			Low level pulse width	tSCKL(3)						1/2	
				tSCKLA(2)						3/4	
		High level pulse width	tSCKH(3)					1/2			
tSCKHA(2)				2							
Output clock	Cycle time	tSCK(4)	SCK1(P15)	• CMOS output • Refer to figure 6	3.0-5.5	2		tCYC			
	Low level pulse width	tSCKL(4)					1/2		tSCK		
		tSCKH(4)					1/2				
Serial input	Data set-up time	tsDI	SI0(P10), SI1(P13), SB0(P11), SB1(P14)	• Measured with respect to SI0CLK leading edge. • Refer to figure 6	4.5-5.5	0.03		μs			
					3.0-5.5	0.1					
	Data hold time	thDI			4.5-5.5	0.03					
					3.0-5.5	0.1					
Serial output	Output delay time	tdDO	SO0(P12), SO1(P15), SB0(P11), SB1(P14)	• When Port is open drain: Time delay from SIOCLK trailing edge to the SO data change • Refer to figure 6	4.5-5.5			1/3 tCYC +0.05			
					3.0-5.5			1/3 tCYC +0.25			

LC87F72C8A

5. Pulse Input Conditions at Ta=-20°C to +70°C, VSS1=VSS2=VSS3=0V

Parameter	Symbol	Pins	Conditions	Ratings			unit	
				VDD[V]	min.	typ.		max.
High/low level pulse width	tPIH(1) tPIL(1)	INT0(P70), INT1(P71), INT2(P72)	<ul style="list-style-type: none"> Condition that interrupt is accepted Condition that event input to timer 0 is accepted 	3.0-5.5	1			tCYC
	tPIH(2) tPIL(2)	INT3(P73) (Noise rejection ratio is 1/1.)	<ul style="list-style-type: none"> Condition that interrupt is accepted Condition that event input to timer 0 is accepted 	3.0-5.5	2			
	tPIH(3) tPIL(3)	INT3(P73) (Noise rejection ratio is 1/32.)	<ul style="list-style-type: none"> Condition that interrupt is accepted Condition that event input to timer 0 is accepted 	3.0-5.5	64			
	tPIH(4) tPIL(4)	INT3(P73) (Noise rejection ratio is 1/128.)	<ul style="list-style-type: none"> Condition that interrupt is accepted Condition that event input to timer 0 is accepted 	3.0-5.5	256			
	tPIL(5) tPIL(5)	MICIN(P87)	<ul style="list-style-type: none"> Condition that signal is accepted to small signal detection counter. 	3.0-5.5	1			
	tPIL(6)	$\overline{\text{RES}}$	<ul style="list-style-type: none"> Condition that reset is accepted 	3.0-5.5	200			

6. AD converter Characteristics at Ta=-20°C to +70°C, VSS1=VSS2=VSS3=0V

Parameter	Symbol	Pins	Conditions	Ratings			unit	
				VDD[V]	min.	typ.		max.
Resolution	N	AN0(P80)		3.0-5.5		8		bit
Absolute precision	ET	-AN7(P87)	(Note2)	3.0-5.5			±1.5	LSB
Conversion time	TCAD	AN8(P70) AN9(P71) AN10(XT1) AN11(XT2)	AD conversion time = 32 × tCYC (ADCR2=0) (Note 3)	4.0-5.5	15.62 (tCYC=0.488μs)		97.92 (tCYC=3.06μs)	μs
				3.0-5.5	23.52 (tCYC=0.735μs)		97.92 (tCYC=3.06μs)	
			AD conversion time = 64 × tCYC (ADCR2=1) (Note 3)	4.5-5.5	18.82 (tCYC=0.294μs)		97.92 (tCYC=1.53μs)	
				3.0-5.5	47.04 (tCYC=0.735μs)		97.92 (tCYC=1.53μs)	
Analog input voltage range	VAIN			3.0-5.5	VSS		VDD	V
Analog port input current	IAINH		VAIN=VDD	3.0-5.5			1	μA
	IAINL		VAIN=VSS	3.0-5.5	-1			

(Note 2) Absolute precision does not include quantizing error (±1/2 LSB).

(Note 3) Conversion time means time from executing AD conversion instruction to loading complete digital value to register.

7. Current Consumption Characteristics at Ta=-20°C to +70°C, VSS1=VSS2=VSS3=0V

Parameter	Symbol	Pins	Conditions	Ratings			unit	
				VDD[V]	min.	typ.		max
Current consumption during normal operation (Note 4)	IDDOP(1)	VDD1= VDD2= VDD3	<ul style="list-style-type: none"> • FmCF=10MHz Ceramic resonator oscillation • FsX'tal=32.768kHz crystal oscillation • System clock: CF 10MHz oscillation • Internal RC oscillation stopped. • Divider : 1/1 	4.5-5.5		18	35	mA
	IDDOP(2)		<ul style="list-style-type: none"> • CF1=20MHz external clock • FsX'tal=32.768kHz crystal oscillation • System clock: CF1 oscillation • Internal RC oscillation stopped. • Divider :1/2 	4.5-5.5		19	36	
	IDDOP(3)		<ul style="list-style-type: none"> • FmCF=4MHz Ceramic resonator oscillation • FsX'tal=32.768kHz crystal oscillation • System clock: CF 4MHz oscillation • Internal RC oscillation stopped. • Divider :1/1 	4.5-5.5		10	22	
	IDDOP(4)		<ul style="list-style-type: none"> • FmCF=0Hz (No oscillation) • FsX'tal=32.768kHz crystal oscillation • System clock: RC oscillation • Divider :1/2 	3.0-4.5		5.5	14	
	IDDOP(5)		<ul style="list-style-type: none"> • FmCF=0Hz (No oscillation) • FsX'tal=32.768kHz crystal oscillation • System clock: RC oscillation • Divider :1/2 	4.5-5.5		6	15	
	IDDOP(6)		<ul style="list-style-type: none"> • FmCF=0Hz (No oscillation) • FsX'tal=32.768kHz crystal oscillation • System clock: RC oscillation • Divider :1/2 	3.0-4.5		3	12	
	IDDOP(7)		<ul style="list-style-type: none"> • FmCF=0Hz (No oscillation) • FsX'tal=32.768kHz crystal oscillation • System clock: 32.768kHz • Internal RC oscillation stopped. • Divider :1/2 	4.5-5.5		4.5	14	
	IDDOP(8)		<ul style="list-style-type: none"> • FmCF=0Hz (No oscillation) • FsX'tal=32.768kHz crystal oscillation • System clock: 32.768kHz • Internal RC oscillation stopped. • Divider :1/2 	3.0-4.5		2	9	

Continued/

Parameter	Symbol	Pins	Conditions	Ratings			unit	
				VDD[V]	min.	typ.		max.
Current consumption during HALT mode (Note 4)	IDDHALT(1)	VDD1= VDD2= VDD3	HALT mode • FmCF=10MHz Ceramic resonator oscillation • FsX'tal=32.768kHz crystal oscillation • System clock : CF 10MHz oscillation • Internal RC oscillation stopped. • Divider: 1/1	4.5-5.5		6	12	mA
	IDDHALT(2)		HALT mode • CF1=20MHz external clock • FsX'tal=32.768kHz crystal oscillation • System clock : CF1 oscillation • Internal RC oscillation stopped. • Divider :1/2	4.5-5.5		7	13	
	IDDHALT(3)		HALT mode • FmCF=4MHz Ceramic resonator oscillation • FsX'tal=32.768kHz crystal oscillation	4.5-5.5		2.5	6	
	IDDHALT(4)		• System clock : CF 4MHz oscillation • Internal RC oscillation stopped. • Divider: 1/1	3.0-4.5		1.5	5	
	IDDHALT(5)		HALT mode • FmCF=0Hz (Oscillation stop) • FsX'tal=32.768kHz crystal oscillation	4.5-5.5		600	1600	μA
	IDDHALT(6)		• System clock : RC oscillation • Divider: 1/2	3.0-4.5		300	1300	
	IDDHALT(7)		HALT mode • FmCF=0Hz (Oscillation stop) • FsX'tal=32.768kHz crystal oscillation	4.5-5.5		25	100	
	IDDHALT(8)		• System clock : 32.768kHz • Internal RC oscillation stopped. • Divider: 1/2	3.0-4.5		12	60	

Continued/

LC87F72C8A

Parameter	Symbol	Pins	Conditions	Ratings			unit	
				VDD[V]	min.	typ.		max.
Current consumption during HOLD mode	IDDHOLD(1)	VDD1	HOLD mode • CF1=VDD or open (when using external clock)	4.5–5.5		0.015	25	μA
	IDDHOLD(2)			3.0–4.5		0.015	20	
Current consumption during Date/time clock HOLD mode	IDDHOLD(3)	VDD1	Date/time clock HOLD mode • CF1=VDD or open (when using external clock) • FmX'tal=32.768kHz crystal oscillation	4.5–5.5		20	100	
	IDDHOLD(4)			3.0–4.5		8	55	

(Note 4) The currents through the output transistors and the pull-up MOS transistors are ignored.

8. F-ROM Write Characteristics at Ta=+10 to +55°C, VSSI=VSS2=VSS3=0V

Parameter	Symbol	Pins	Conditions	Ratings			unit	
				VDD[V]	min.	typ.		max.
On board write current	IDDF(1)	VDD1	• 128-byte write • Including erase current	4.5–5.5		30	65	mA
Write cycle time	tFW(1)		• 128-byte write • Including erase current • Not including time to prepare 128-byte data	4.5–5.5		6.3	9	mS

Main system clock oscillation circuit characteristics

The characteristics in the table bellow is based on the following conditions:

1. Use the standard evaluation board SANYO has provided.
2. Use the peripheral parts with indicated value externally.
3. The peripheral parts value is a recommended value of oscillator manufacturer

Table 1. Main system clock oscillation circuit characteristics using ceramic resonator

Frequency	Manufacturer	Oscillator	Circuit parameters			Operating supply voltage range	Oscillation stabilizing time		Notes
			C1	C2	Rd1		typ	max	
10MHz	Murata	CSA10.0MTZ	33pF	33pF	470Ω	4.5 – 5.5V	0.09ms	0.4ms	
		CST10.0MTW	(30pF)	(30pF)	470Ω	4.5 – 5.5V	0.09ms	0.4ms	Built in C1,C2
4MHz	Murata	CSA4.00MG	33pF	33pF	680Ω	3.0 – 5.5V	0.07ms	0.2ms	
		CST4.00MGW	(30pF)	(30pF)	680Ω	3.0 – 5.5V	0.07ms	0.2ms	Built in C1,C2

The oscillation stabilizing time is a period until the oscillation becomes stable after VDD becomes higher than minimum operating voltage. (Refer to Figure4)

Subsystem clock oscillation circuit characteristics

The characteristics in the table bellow is based on the following conditions:

1. Use the standard evaluation board SANYO has provided.
2. Use the peripheral parts with indicated value externally.
3. The peripheral parts value is a recommended value of oscillator manufacturer

Table 2. Subsystem clock oscillation circuit characteristics using crystal oscillator

Frequency	Manufacturer	Oscillator	Circuit parameters				Operating supply voltage range	Oscillation stabilizing time		Notes
			C3	C4	Rf	Rd2		typ	max	
32.768MHz	Seiko EPSON	C-002RX	18pF	18pF	OPEN	390kΩ	3.0 – 5.5V	1.0s	3.0s	
		MC-306								

The oscillation stabilizing time is a period until the oscillation becomes stable after executing the instruction which starts the sub-clock oscillation or after releasing the HOLD mode. (Refer to Figure4)

(Notes) • Since the circuit pattern affects the oscillation frequency, place the oscillation-related parts as close to the oscillation pins as possible with the shortest possible pattern length.

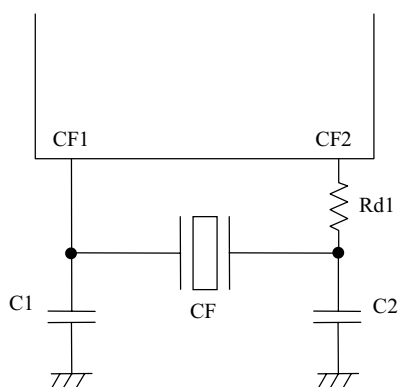

Figure 1 Ceramic oscillation circuit

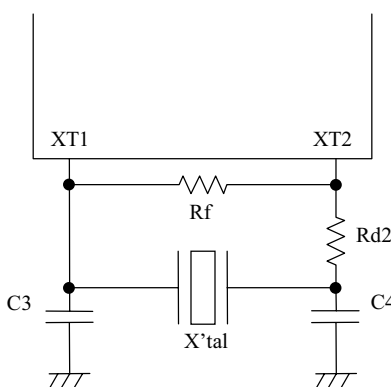

Figure 2 Crystal oscillation circuit

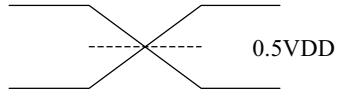

Figure 3 AC timing measurement point

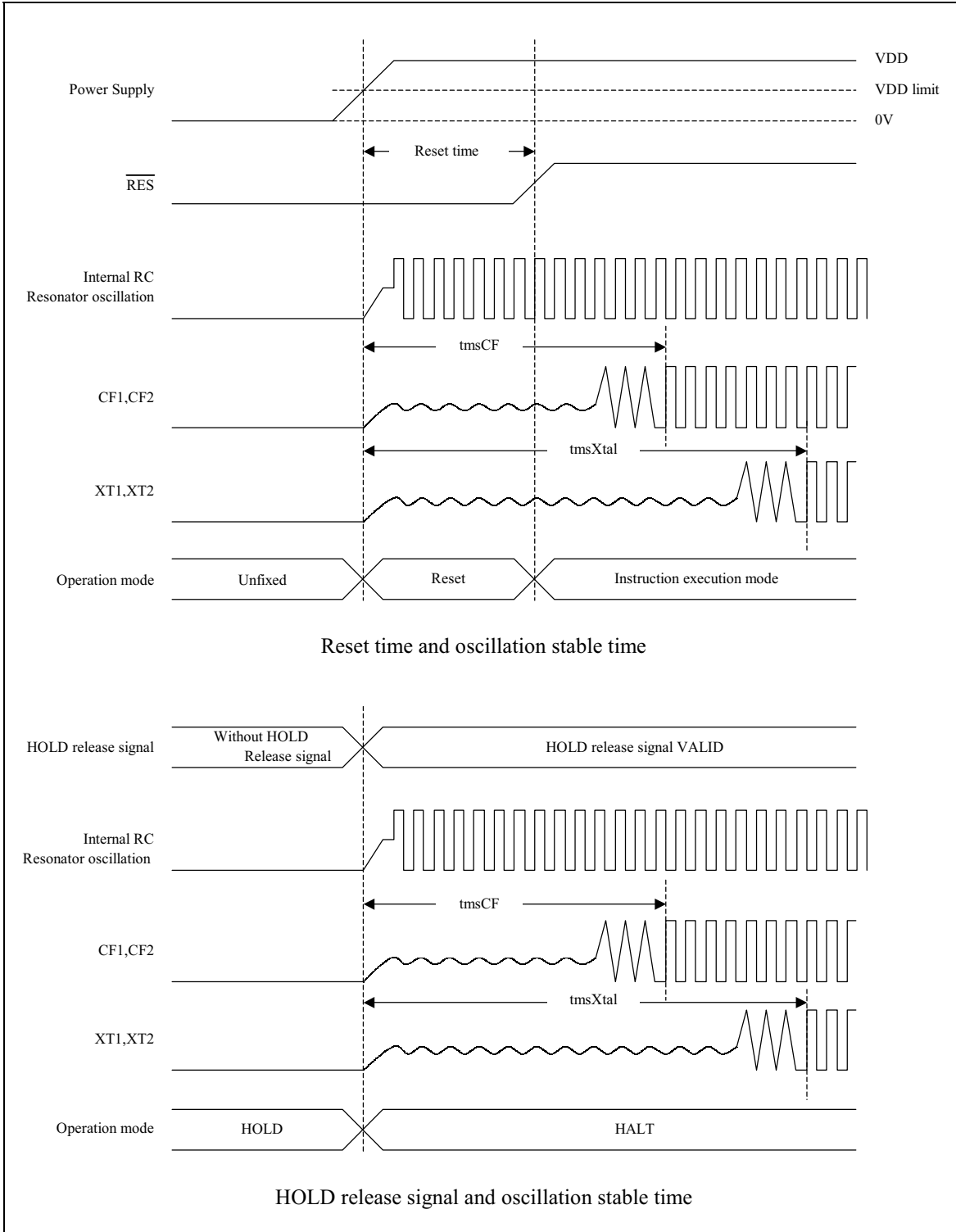
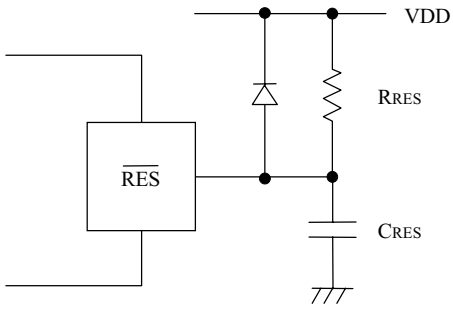

Figure 4 Oscillation stabilizing time



(Note)
 Select CRES and RRES value to assure that at least 200μs reset time is generated after the VDD becomes higher than the minimum operating voltage.

Figure 5 Reset circuit

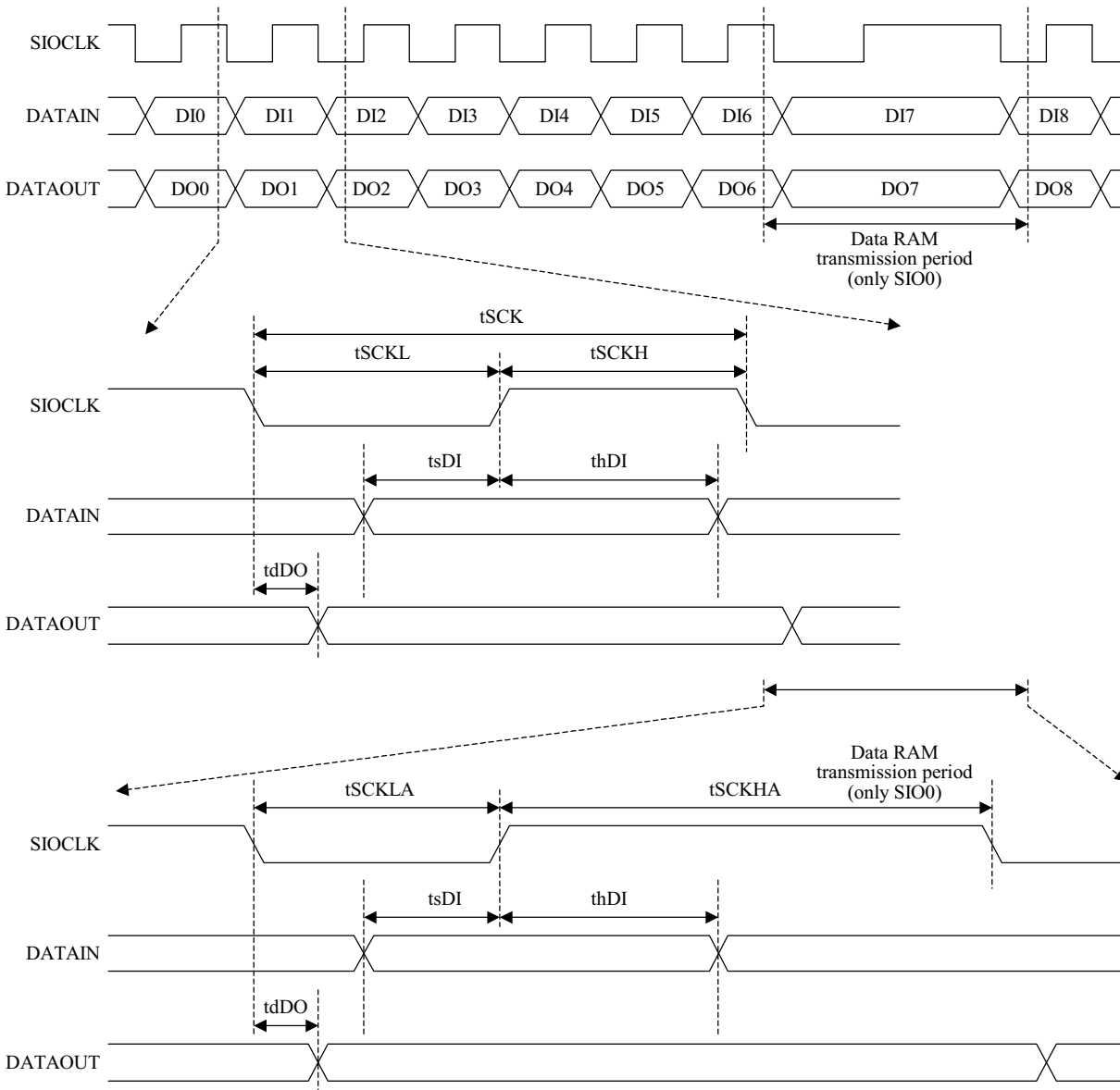

Figure 6 Serial input / output wave form

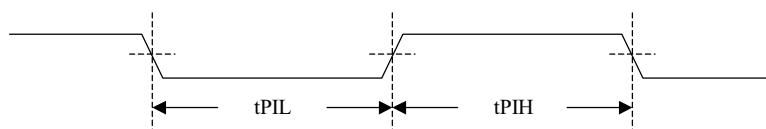

Figure 7 Pulse input timing

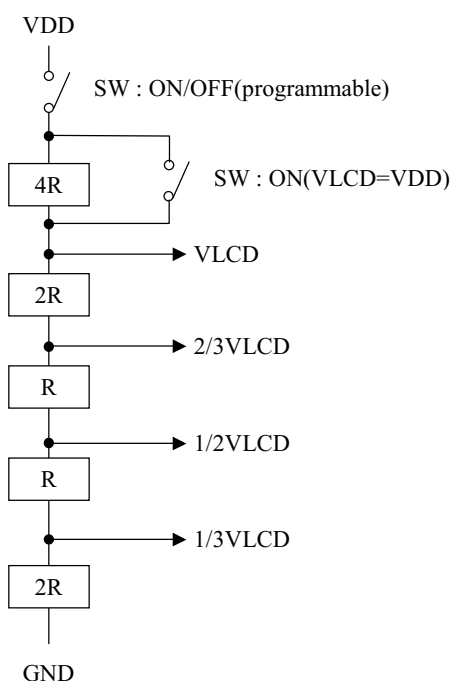

Figure 8 LCD bias resistor

- Specifications of any and all SANYO products described or contained herein stipulate the performance, characteristics, and functions of the described products in the independent state, and are not guarantees of the performance, characteristics, and functions of the described products as mounted in the customer's products or equipment. To verify symptoms and states that cannot be evaluated in an independent device, the customer should always evaluate and test devices mounted in the customer's products or equipment.
- SANYO Electric Co., Ltd. strives to supply high-quality high-reliability products. However, any and all semiconductor products fail with some probability. It is possible that these probabilistic failures could give rise to accidents or events that could endanger human lives, that could give rise to smoke or fire, or that could cause damage to other property. When designing equipment, adopt safety measures so that these kinds of accidents or events cannot occur. Such measures include but are not limited to protective circuits and error prevention circuits for safe design, redundant design, and structural design.
- In the event that any or all SANYO products (including technical data, services) described or contained herein are controlled under any of applicable local export control laws and regulations, such products must not be exported without obtaining the export license from the authorities concerned in accordance with the above law.
- No part of this publication may be reproduced or transmitted in any form or by any means, electronic or mechanical, including photocopying and recording, or any information storage or retrieval system, or otherwise, without the prior written permission of SANYO Electric Co., Ltd.
- Any and all information described or contained herein are subject to change without notice due to product/technology improvement, etc. When designing equipment, refer to the "Delivery Specification" for the SANYO product that you intend to use.
- Information (including circuit diagrams and circuit parameters) herein is for example only; it is not guaranteed for volume production. SANYO believes information herein is accurate and reliable, but no guarantees are made or implied regarding its use or any infringements of intellectual property rights or other rights of third parties.

This catalog provides information as of April, 2002. Specifications and information herein are subject to change without notice.