



H7805AE

H7805BE

3-TERMINAL POSITIVE VOLTAGE REGULATOR

Description

The H7805_E series of three-terminal positive regulators are available in the TO-220AB package. These regulators can provide local on-card regulation, eliminating the distribution problems associated with single point regulation. Each employs internal current limiting, thermal shut-down and safe operating area protection, making it essentially indestructible. If adequate heat sinking is provided, they can deliver over 1A output current. Although designed primarily as fixed voltage regulators, these devices can be used with external components to obtain adjustable voltages and currents. H7805_E is characterized for operation from 0°C to +125°C, and if operating temperature is always high, please refer to the power dissipation curve.

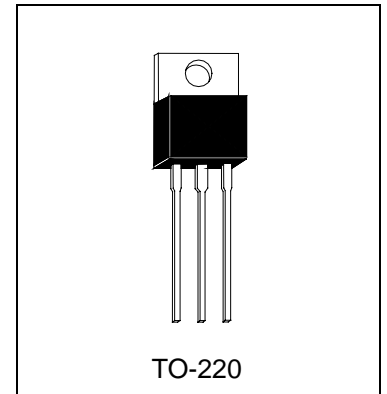

Absolute Maximum Ratings (Ta=25°C)

- Input Voltage..... 35 V
- Total Power Dissipation..... Internally limited
- Operating Temperature Range 0 °C to +125 °C
- Maximum Junction Temperature..... 125 °C
- Storage Temperature Range..... -55 °C to +150 °C
- Lead Temperature (Soldering 10S)..... 230 °C

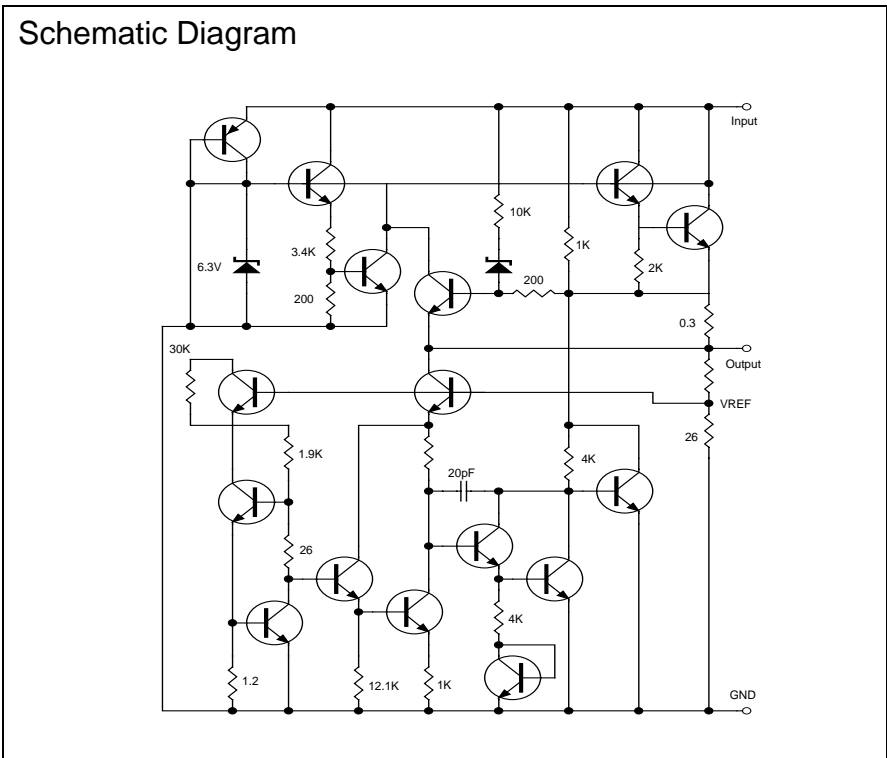
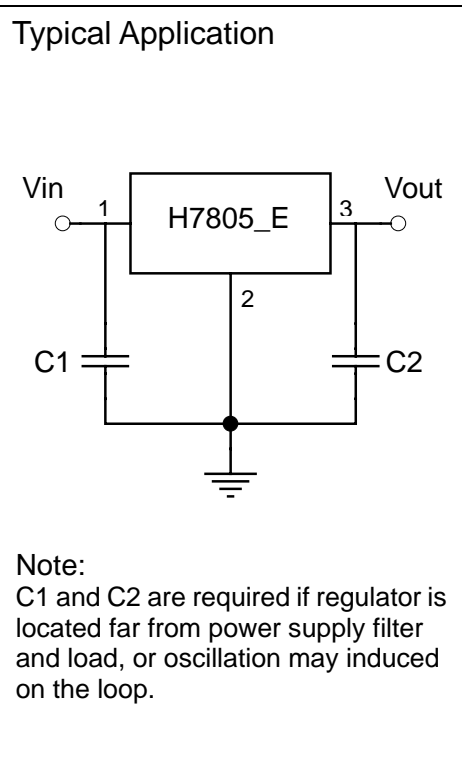



Electrical Characteristics

Vin=10V, Io=500mA, 0°C≤Tj≤125°C (unless otherwise noted)

Symbol	Parameter	Conditions	H7805AE			Units
			Min	Typ	Max	
Vo	Output Voltage	Tj=25°C	4.85	5	5.15	V
		PD≤15W, 5mA≤Io≤1A	4.85	5	5.15	
ΔVo	Line Regulation	Tj=25°C, 7V≤Vin≤25V	-	4	50	mV
		Tj=25°C, 8V≤Vin≤25V	-	1.6	25	
ΔVo	Load Regulation	5mA≤Io≤1.5A	-	-	100	mV
		250mA≤Io≤750mA	-	-	50	
IQ	Quiescent Current	Io≤1A, Tj=25°C	-	5.5	8	mA
ΔIQ	Quiescent Current Change	5mA≤Io≤1A	-	-	0.5	mA
		7V≤Vin≤25V	-	-	1.3	
Vn	Output Noise Voltage	Ta=25°C, 10Hz≤f≤100KHz	-	40	200	uV
RR	Ripple Rejection	8V≤Vin≤18V, f=120Hz	-	68	-	dB
VD	Dropout Voltage	Tj=25°C, Io=1A	-	2	-	V
Isc	Short Circuit Current	Tj=25°C	-	1.5	-	A
Ipk	Peak Output Current	Tj=25°C	1.7	-	-	A
ΔVo / ΔT	Average Tc of Vout	0°C≤Tj≤+125°C, Io=5mA	-	-0.8	-	mV/°C

Symbol	Parameter	Conditions	H7805BE			Units
			Min	Typ	Max	
Vo	Output Voltage	Tj=25°C	4.8	5	5.2	V
		PD≤15W, 5mA≤Io≤1A	4.75	5	5.25	
ΔVo	Line Regulation	Tj=25°C, 7V≤Vin≤25V	-	4	100	mV
		Tj=25°C, 8V≤Vin≤25V	-	1.6	50	
ΔVo	Load Regulation	5mA≤Io≤1.5A	-	-	100	mV
		250mA≤Io≤750mA	-	-	50	
IQ	Quiescent Current	Io≤1A, Tj=25°C	-	5.5	8	mA
ΔIQ	Quiescent Current Change	5mA≤Io≤1A	-	-	0.5	mA
		7V≤Vin≤25V	-	-	1.3	
Vn	Output Noise Voltage	Ta=25°C, 10Hz≤f≤100KHz	-	100	300	uV
RR	Ripple Rejection	8V≤Vin≤18V, f=120Hz	62	73	-	dB
VD	Dropout Voltage	Tj=25°C, Io=1A	-	2.5	-	V
Isc	Short Circuit Current	Tj=25°C	-	1.5	-	A
Ipk	Peak Output Current	Tj=25°C	1.7	-	-	A
ΔVo / ΔT	Average Tc of Vout	0°C≤Tj≤+125°C, Io=5mA	-	-0.8	-	mV/°C



TO-220AB Dimension

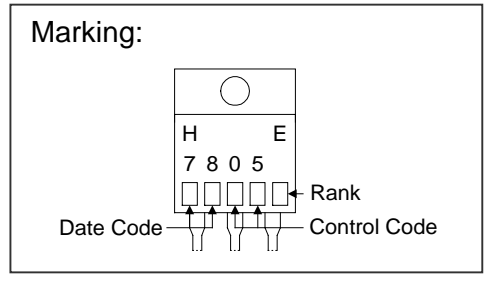
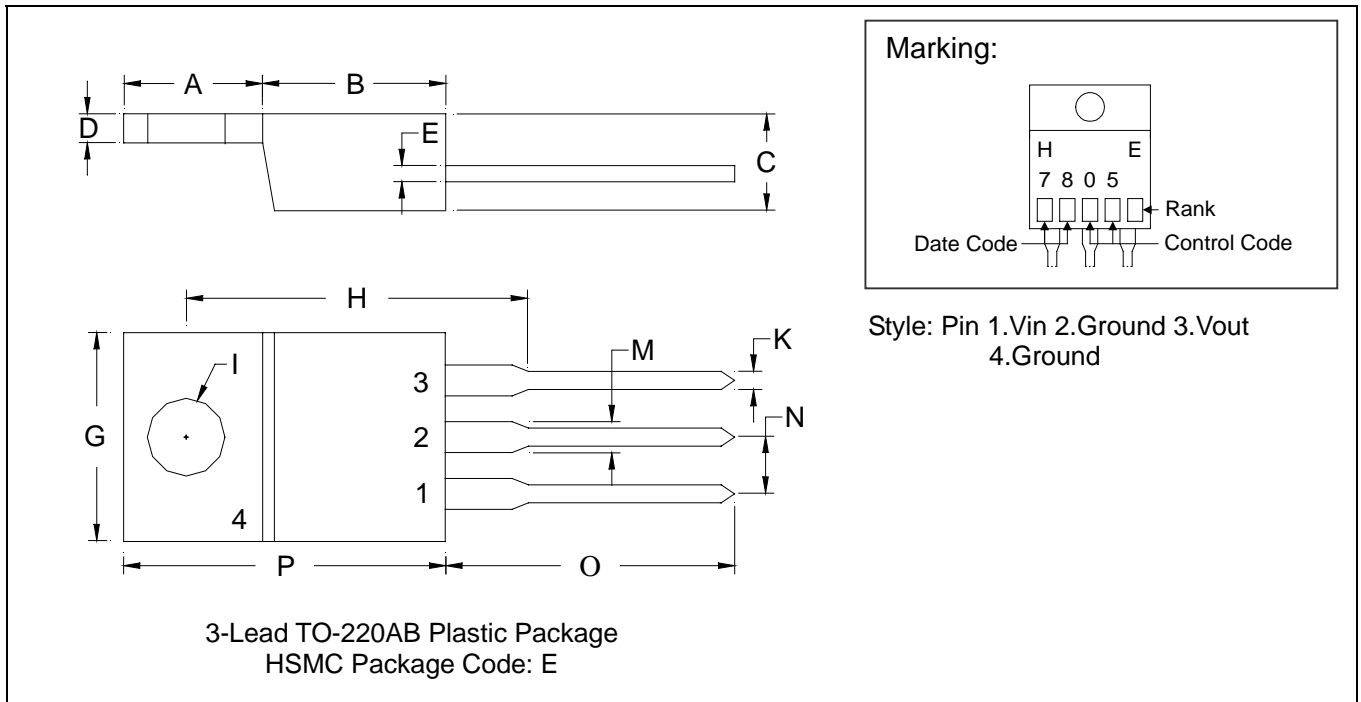

Style: Pin 1.Vin 2.Ground 3.Vout
 4.Ground

*: Typical

DIM	Inches		Millimeters		DIM	Inches		Millimeters	
	Min.	Max.	Min.	Max.		Min.	Max.	Min.	Max.
A	0.2197	0.2949	5.58	7.49	I	-	*0.1508	-	*3.83
B	0.3299	0.3504	8.38	8.90	K	0.0295	0.0374	0.75	0.95
C	0.1732	0.185	4.40	4.70	M	0.0449	0.0551	1.14	1.40
D	0.0453	0.0547	1.15	1.39	N	-	*0.1000	-	*2.54
E	0.0138	0.0236	0.35	0.60	O	0.5000	0.5618	12.70	14.27
G	0.3803	0.4047	9.66	10.28	P	0.5701	0.6248	14.48	15.87
H	-	*0.6398	-	*16.25					

Notes: 1.Dimension and tolerance based on our Spec. dated Sep. 07,1997.
 2.Controlling dimension: millimeters.
 3.Maximum lead thickness includes lead finish thickness, and minimum lead thickness is the minimum thickness of base material.
 4.If there is any question with packing specification or packing method, please contact your local HSMC sales office.

Material:

- Lead: 42 Alloy ; solder plating
- Mold Compound: Epoxy resin family, flammability solid burning class: UL94V-0

Important Notice:

- All rights are reserved. Reproduction in whole or in part is prohibited without the prior written approval of HSMC.
- HSMC reserves the right to make changes to its products without notice.
- **HSMC semiconductor products are not warranted to be suitable for use in Life-Support Applications, or systems.**
- HSMC assumes no liability for any consequence of customer product design, infringement of patents, or application assistance.

Head Office And Factory:

- **Head Office** (Hi-Sincerity Microelectronics Corp.): 10F.,No. 61, Sec. 2, Chung-Shan N. Rd. Taipei Taiwan R.O.C.
 Tel: 886-2-25212056 Fax: 886-2-25632712, 25368454
- **Factory 1:** No. 38, Kuang Fu S. Rd., Fu-Kou Hsin-Chu Industrial Park Hsin-Chu Taiwan. R.O.C
 Tel: 886-3-5983621~5 Fax: 886-3-5982931