

# DATA SHEET

**TDA9183**

**Integrated NTSC comb filter**

Objective specification  
Supersedes data of 2000 Nov 22  
File under Integrated Circuits, IC02

2000 Nov 30

## Integrated NTSC comb filter

## TDA9183

### FEATURES

- One-chip NTSC adaptive comb filter
- Cross luminance reduction
- Cross colour reduction
- No chroma trap, therefore sharper vertical luminance transients
- Analog discrete-time signal processing, therefore no quantization noise
- Anti-aliasing and reconstruction filters are included
- Input switch selects between two Y/CVBS inputs
- Output switch selects between combed CVBS and an external Y/C source
- $f_{SC}$  as well as  $2 \times f_{SC}$  colour subcarrier signal may be applied
- Alignment free
- Few external components
- Low power.

### GENERAL DESCRIPTION

The TDA9183 is an adaptive NTSC comb filter with two internal delay lines, filters, clock control and input clamps. The NTSC M video standard is supported.

Two CVBS input signals can be selected by means of an input switch.

The selected CVBS input signal is filtered to obtain a combed luminance output signal and a combed chrominance output signal. Switched capacitor circuit techniques are used, requiring an internal clock, locked on to the colour subcarrier frequency.

The colour subcarrier frequency as well as twice the colour subcarrier frequency may be applied to the IC.

In addition to the comb filter the circuit contains an output switch so that a selection can be made between the combed CVBS signal and an external Y/C signal.

The IC is available in a DIP16 and SO16 package. The supply voltage is 5 V.

### QUICK REFERENCE DATA

SYMBOL	PARAMETER	MIN.	TYP.	MAX.	UNIT
$V_{CCA}$	analog supply voltage	4.5	5.0	5.5	V
$I_{CCA}$	analog supply current	–	25	–	mA
$V_{DDD}$	digital supply voltage	4.5	5.0	5.5	V
$I_{DDD}$	digital supply current	–	10	–	mA
$V_{i(Y/CVBS)(p-p)}$	luminance or CVBS input signal voltage (peak-to-peak value)	0.7	1.0	1.4	V
$V_{i(CIN)(p-p)}$	chrominance input signal voltage (peak-to-peak value)	–	0.7	1.0	V
$V_{i(FSC)(p-p)}$	colour subcarrier input signal voltage (peak-to-peak value)	100	200	400	mV
$V_{o(Y/CVBS)(p-p)}$	luminance or CVBS output signal voltage (peak-to-peak value)	0.6	1.0	1.54	V
$V_{o(CIN)(p-p)}$	chrominance output signal voltage (peak-to-peak value)	–	0.7	1.1	V

### ORDERING INFORMATION

TYPE NUMBER	PACKAGE		
	NAME	DESCRIPTION	VERSION
TDA9183P	DIP16	plastic dual in-line package; 16 leads (300 mil); long body	SOT38-4
TDA9183T	SO16	plastic small outline package; 16 leads; body width 7.5 mm	SOT162-1

Integrated NTSC comb filter

TDA9183

BLOCK DIAGRAM

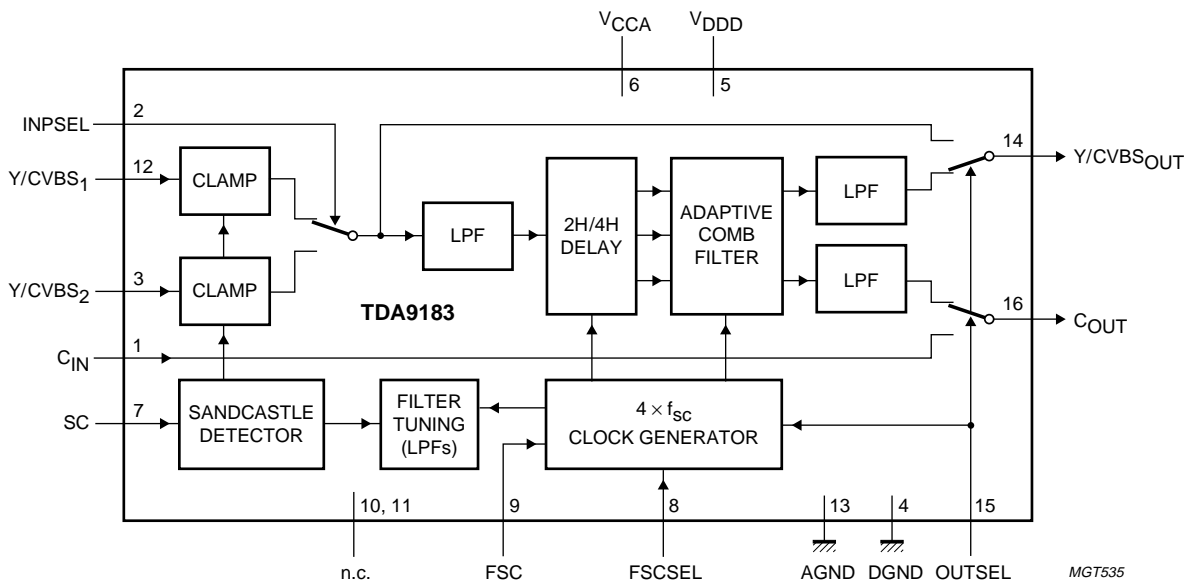

MGT535

Fig.1 Block diagram.

Integrated NTSC comb filter

TDA9183

PINNING

SYMBOL	PIN	DESCRIPTION
C <sub>IN</sub>	1	chrominance signal input
INPSEL	2	input switch select input
Y/CVBS <sub>2</sub>	3	luminance or CVBS signal 2 input
DGND	4	digital ground
V <sub>DDD</sub>	5	digital supply voltage
V <sub>CCA</sub>	6	analog supply voltage
SC	7	sandcastle signal input
FSCSEL	8	colour subcarrier select input
FSC	9	colour subcarrier signal input
n.c.	10	not connected
n.c.	11	not connected
Y/CVBS <sub>1</sub>	12	luminance or CVBS signal 1 input
AGND	13	analog ground (signal reference)
Y/CVBS <sub>OUT</sub>	14	luminance or CVBS signal output
OUTSEL	15	output switch select input
C <sub>OUT</sub>	16	chrominance signal output

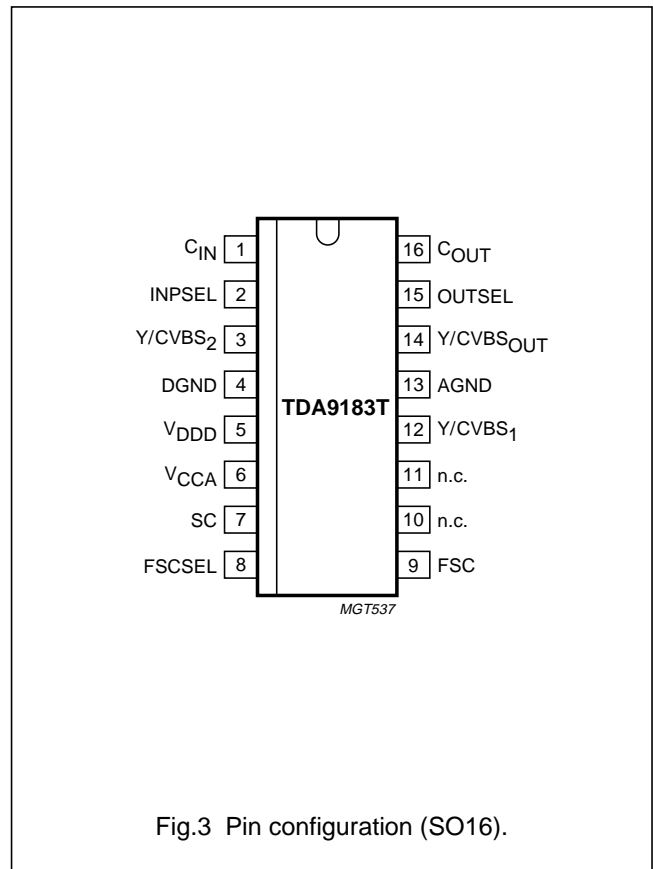
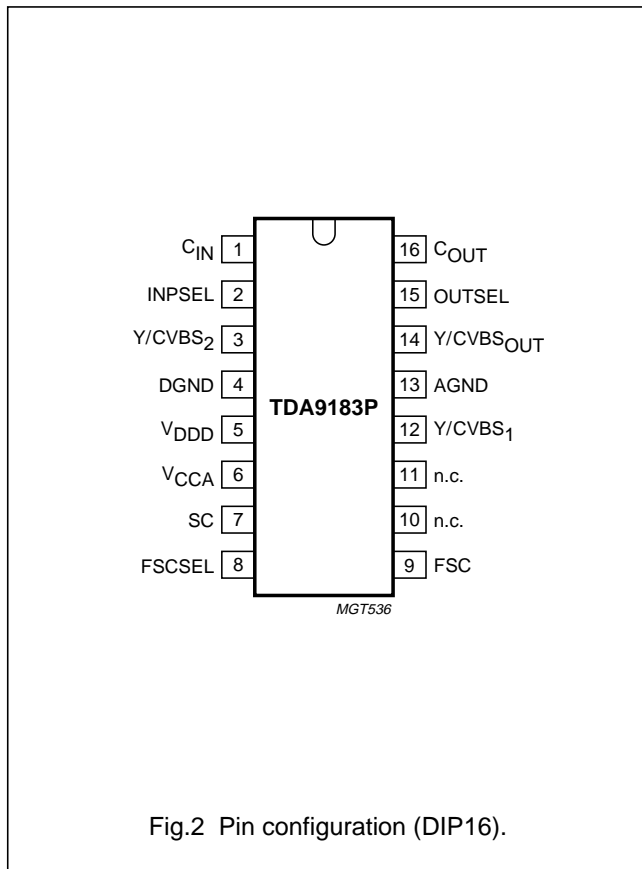

## Integrated NTSC comb filter

TDA9183

### FUNCTIONAL DESCRIPTION

#### Input configuration

The Y/CVBS<sub>1</sub> and Y/CVBS<sub>2</sub> input signals are clamped by means of an internally generated clamp pulse which is derived from the sandcastle input signal (pin SC). If no sandcastle signal is available, a clamp pulse signal may be applied to pin SC. External clamp capacitors are needed.

The buffered and clamped Y/CVBS<sub>1</sub> and Y/CVBS<sub>2</sub> signals are then applied to the input switch. The input switch select signal (INPSEL) determines whether Y/CVBS<sub>1</sub> or Y/CVBS<sub>2</sub> is passed through to the anti-alias low-pass filter. This 3rd-order low-pass filter is optimized for best performance with respect to step response and clock suppression. The filtered signal is sampled at a clock frequency of four times the colour subcarrier frequency ( $f_{SC}$ ).

A colour subcarrier frequency signal is applied to pin FSC. The colour subcarrier select input signal (FSCSEL) indicates whether the colour subcarrier frequency ( $f_{SC}$ ) or twice the colour subcarrier frequency ( $2 \times f_{SC}$ ) is being applied at the FSC input. An external coupling capacitor is needed for the colour subcarrier input signal.

#### Comb filter

The sampled CVBS signal is applied to two delay lines. One delay line delays the signal over 1H (1H = one line-time).

The direct and delayed signals are applied to an adaptive comb filter. The adaptive comb filter performs band-pass filtering around the colour subcarrier frequency and compares the contents of adjacent lines. In this way the combing of signals with different information is prevented and artifacts such as hanging dots are avoided.

Both the combed chrominance and the combed luminance signal are passed through a reconstruction low-pass filter to obtain continuous-time signals. These low-pass filters are 3rd-order, optimized for best performance with respect to step response and clock suppression. The reconstructed signals are applied to the output switches.

#### Output configuration

The luminance output switch selects between the reconstructed combed luminance signal and one of the buffered and clamped input signals Y/CVBS<sub>1</sub> or Y/CVBS<sub>2</sub>. The chrominance output switch selects between the reconstructed combed chrominance signal and the chrominance input signal ( $C_{IN}$ ). An external coupling capacitor is needed for  $C_{IN}$ . The selected signals are applied to the outputs Y/CVBS<sub>OUT</sub> and  $C_{OUT}$  respectively via a buffer stage. The output switch signal (OUTSEL) determines whether the output switches select the internal combed signals or the external Y/C signals.

#### Clock generation and filter tuning

The clock generator is driven by a Phase-Locked Loop (PLL) circuit which generates a reference frequency of four times the colour subcarrier frequency. This PLL circuit is phase-locked to the colour subcarrier input signal (FSC). Several internal clock signals are derived from the  $4 \times f_{SC}$  reference.

The filter tuning ensures the automatic alignment of the anti-alias and the reconstruction low-pass filters. A  $4 \times f_{SC}$  clock signal is used as a reference for the alignment. The tuning takes place each line during the line blanking and is initiated by means of an internally generated signal which is derived from the sandcastle input signal.

If the output switches select external Y/C signals the oscillator of the PLL circuit is stopped regardless of the FSC input and no internal clock signals are generated. The filter tuning is also stopped.

Integrated NTSC comb filter

TDA9183

Mode definitions

Table 1 General mode definitions; note 1

PIN OUTSEL	MODE
LOW	COMB
HIGH	YC

Note

1. If the OUTSEL pin is left open-circuit, the pin is pulled LOW by means of an internal pull-down resistor to analog ground (AGND). Thus the COMB mode can also be selected by not connecting the OUTSEL pin.

Table 2 Y/CVBS<sub>OUT</sub> output signal definitions

MODE	Y/CVBS <sub>OUT</sub> OUTPUT SIGNAL
COMB	comb filtered luminance signal
YC	Y/CVBS <sub>1</sub> or Y/CVBS <sub>2</sub> signal

Table 3 C<sub>OUT</sub> output signal definitions

MODE	C <sub>OUT</sub> OUTPUT SIGNAL
COMB	comb filtered chrominance signal
YC	C <sub>IN</sub> signal

Table 4 Input switch mode definitions; note 1

PIN INPSEL	INPUT SWITCH MODE
LOW	Y/CVBS <sub>1</sub> input selected
HIGH	Y/CVBS <sub>2</sub> input selected

Note

1. If the INPSEL pin is left open-circuit, the pin is pulled LOW by means of an internal pull-down resistor to analog ground (AGND). Thus the Y/CVBS<sub>1</sub> input can also be selected by not connecting the INPSEL pin.

Table 5 FSC mode definitions; note 1

PIN FSCSEL	FSC INPUT SIGNAL FREQUENCY
LOW	f <sub>SC</sub>
HIGH	2 × f <sub>SC</sub>

Note

1. If the FSCSEL pin is left open-circuit, the pin is pulled LOW by means of an internal pull-down resistor to analog ground (AGND). Thus the f<sub>SC</sub> mode can also be selected by not connecting the FSCSEL pin.

## Integrated NTSC comb filter

TDA9183

**LIMITING VALUES**

In accordance with the Absolute Maximum Rating System (IEC 60134).

SYMBOL	PARAMETER	CONDITIONS	MIN.	MAX.	UNIT
$V_{DDD}$	digital supply voltage		–	5.5	V
$V_{CCA}$	analog supply voltage		–	5.5	V
$V_{i(prot)(th)}$	input voltage protection threshold		–0.3	$V_{DD} + 0.3$	V
$T_{stg}$	storage temperature		–25	+150	°C
$T_{amb}$	ambient temperature		–25	+70	°C
$T_{sol}$	soldering temperature	for 5 s	–	260	°C
$T_j$	junction temperature		–	150	°C
$V_{es}$	electrostatic handling voltage	HBM; all pins, except pins 5 and 6; notes 1, 2 and 3	–3000	+3000	V
		MM; all pins, except pins 5 and 6; notes 1, 4 and 5	–300	+300	V

**Notes**

- All pins are protected against ESD by means of internal clamping diodes.
- Human Body Model (HBM):  $R = 1.5 \text{ k}\Omega$ ;  $C = 100 \text{ pF}$ .
- Pins 5 ( $V_{DDD}$ ) and 6 ( $V_{CCA}$ ): HBM:  $-1500 \text{ V} < V_{es} < +1500 \text{ V}$ .
- Machine Model (MM):  $R = 0 \text{ }\Omega$ ;  $C = 200 \text{ pF}$ .
- Pins 5 ( $V_{DDD}$ ) and 6 ( $V_{CCA}$ ): MM:  $-150 \text{ V} < V_{es} < +150 \text{ V}$ .

**THERMAL CHARACTERISTICS**

SYMBOL	PARAMETER	CONDITIONS	VALUE	UNIT
$R_{th(j-a)}$	thermal resistance from junction to ambient	in free air		
	TDA9183P		75	K/W
	TDA9183T		95	K/W

**QUALITY SPECIFICATION**

In accordance with "SNW-FQ-611E".

**Latch-up**

At an ambient temperature of 70 °C all pins meet the following specification:

- $I_{trigger} \geq 100 \text{ mA}$  or  $V_{trigger} \geq 1.5V_{DD(max)}$
- $I_{trigger} \leq -100 \text{ mA}$  or  $V_{trigger} \leq -0.5V_{DD(max)}$

## Integrated NTSC comb filter

TDA9183

**CHARACTERISTICS**

$V_{CCA} = V_{DDD} = 5\text{ V}$ ;  $T_{amb} = 25\text{ °C}$ ; input signal  $Y/CVBS_1 = 1\text{ V}$  (p-p); input signal  $Y/CVBS_2 = 1\text{ V}$  (p-p); input signal  $C_{IN} = 0.7\text{ V}$  (p-p); input signal FSC = 200 mV (p-p) sine wave at  $f_{SC}$ ; input signal SC = 5 V (p-p) sandcastle signal; test signal: 100% white 75% amplitude FCC colour bar; source impedance for  $Y/CVBS_1$  and  $Y/CVBS_2 = 75\ \Omega$ ; coupled with 10 nF; source impedance for  $C_{IN}$  and FSC =  $75\ \Omega$ ; coupled with 100 nF; load impedance for  $CVBS/Y_{OUT}$  and  $C_{OUT} = 15\text{ pF}$  to analog ground (pin AGND); all voltages are related to analog ground (pin AGND); unless otherwise specified.

SYMBOL	PARAMETER	CONDITIONS	MIN.	TYP.	MAX.	UNIT
<b>Supplies</b>						
$V_{CCA}$	analog supply voltage		4.5	5.0	5.5	V
$I_{CCA}$	analog supply current		–	25	–	mA
$V_{DDD}$	digital supply voltage		4.5	5.0	5.5	V
$I_{DDD}$	digital supply current		–	10	–	mA
P	power dissipation		–	175	–	mW
<b>Luminance or CVBS input 1 and 2; pins <math>Y/CVBS_1</math> and <math>Y/CVBS_2</math></b>						
$V_{i(Y/CVBS)(p-p)}$	luminance or CVBS input voltage (peak-to-peak value)	including sync	0.7	1.0	1.4	V
$t_{clamp(Y/CVBS)}$	clamp time constant		–	20	–	lines
$I_{i(Y/CVBS)}$	input current	during clamping	–10	0	+10	$\mu\text{A}$
		during active video	–10	0	+10	nA
<b>Chrominance input; pin <math>C_{IN}</math></b>						
$V_{i(CIN)(p-p)}$	chrominance input voltage (peak-to-peak value)		–	0.7	1.0	V
$R_{i(CIN)}$	input resistance		30	–	–	k $\Omega$
<b>Colour subcarrier input; pin FSC</b>						
$V_{i(FSC)(p-p)}$	subcarrier input voltage (peak-to-peak value)		100	200	400	mV
D	duty cycle	square wave	40	50	60	%
$R_{i(FSC)}$	input resistance		30	–	–	k $\Omega$
<b>Sandcastle input; pin SC</b>						
$V_{i(SC)}$	sandcastle input voltage	no clamping	–	–	3.3	V
		clamping	3.7	–	–	V
$t_W$	pulse width	clamping; note 1	2.6	–	–	$\mu\text{s}$
$t_{W(rep)}$	input pulse rising edge position	with respect to the end of line blanking; note 1	–	–	–2.6	$\mu\text{s}$
$R_{i(SC)}$	input resistance		1	–	–	M $\Omega$
$C_{i(SC)}$	input capacitance		–	–	2	pF
<b>Input switch select input; pin INPSEL</b>						
$V_{IL}$	LOW-level input voltage	$Y/CVBS_1$ selected	–	–	0.5	V
$V_{IH}$	HIGH-level input voltage	$Y/CVBS_2$ selected	2.0	–	–	V
$R_{i(INPSEL)}$	input resistance		100	–	–	k $\Omega$
$C_{i(INPSEL)}$	input capacitance		–	–	2	pF



## Integrated NTSC comb filter

TDA9183

SYMBOL	PARAMETER	CONDITIONS	MIN.	TYP.	MAX.	UNIT
<b>Output switch select input; pin OUTSEL</b>						
V <sub>IL</sub>	LOW-level input voltage	COMB mode	–	–	0.5	V
V <sub>IH</sub>	HIGH-level input voltage	YC mode	2.0	–	–	V
R <sub>i(OUTSEL)</sub>	input resistance		100	–	–	kΩ
C <sub>i(OUTSEL)</sub>	input capacitance		–	–	2	pF
<b>Colour subcarrier select input; pin FSCSEL</b>						
V <sub>IL</sub>	LOW-level input voltage	f <sub>SC</sub> at FSC input; note 2	–	–	0.5	V
V <sub>IH</sub>	HIGH-level input voltage	2 × f <sub>SC</sub> at FSC input	2.0	–	–	V
R <sub>i(FSCSEL)</sub>	input resistance		100	–	–	kΩ
C <sub>i(FSCSEL)</sub>	input capacitance		–	–	2	pF
<b>Luminance output; pin Y/CVBS<sub>OUT</sub></b>						
V <sub>o(Y/CVBSOUT)(p-p)</sub>	luminance output signal (peak-to-peak value)	including sync	0.6	1.0	1.54	V
E <sub>G(Y)</sub>	luminance gain error		–1	0	+1	dB
B <sub>–3dB(Y)</sub>	–3 dB luminance bandwidth	COMB mode	5	–	–	MHz
		YC mode	10	–	–	MHz
t <sub>d(proc)(Y)</sub>	luminance processing delay	COMB mode; note 3	–	800	–	ns
		YC mode	–	15	–	ns
V <sub>clamp</sub>	voltage level during clamping		–	1.5	–	V
E <sub>bl</sub>	black level error	during blanking; note 4	–10	0	+10	mV
S/N	luminance signal-to-noise ratio (1 V/V <sub>rms</sub> noise)	unweighted; 200 kHz to 5 MHz	56	–	–	dB
α <sub>ct</sub>	crosstalk between different inputs	0 to 5 MHz	–	–	–50	dB
f <sub>clk(res)(Y)</sub>	residues of clock frequencies in the luminance signal (V <sub>rms</sub> /1 V)	COMB mode; note 2				
		f = 4 × f <sub>SC</sub>	–	–	–30	dB
		f = 2 × f <sub>SC</sub>	–	–	–30	dB
		f = 1.33 × f <sub>SC</sub>	–	–	–30	dB
FSC <sub>res(YC)</sub>	FSC residue in YC mode (V <sub>rms</sub> /1 V)	f = f <sub>SC</sub> ; f <sub>SC</sub> at FSC input; note 2	–	–	–60	dB
		f = 2 × f <sub>SC</sub> ; 2 × f <sub>SC</sub> at FSC input	–	–	–60	dB
α <sub>ct</sub>	crosstalk suppression at vertical transient black ↔ multi-burst (1 V/V (p-p))	vertical transition active video ↔ vertical blanking; note 5 and Fig.5	26	–	–	dB

## Integrated NTSC comb filter

TDA9183

SYMBOL	PARAMETER	CONDITIONS	MIN.	TYP.	MAX.	UNIT
SUP <sub>comb(Y)</sub>	suppression (comb depth) with respect to luminance band-pass nearest to f <sub>SC</sub>	COMB mode; note 2 and Fig.6				
		f = f <sub>SC</sub>	30	–	–	dB
		$f = \frac{227.5 - 59}{227.5} \times f_{SC}$	–	10	–	dB
		$f = \frac{227.5 + 59}{227.5} \times f_{SC}$	–	10	–	dB
R <sub>o</sub>	output resistance		–	–	500	Ω
Z <sub>L</sub>	load impedance		–	–	15	pF
<b>Chrominance output; pin C<sub>OUT</sub></b>						
V <sub>o(COUT)(p-p)</sub>	chrominance output signal (peak-to-peak value)		–	0.7	1.1	V
E <sub>G(chrom)</sub>	chrominance gain error		–1	0	+1	dB
B <sub>–3dB(chrom)</sub>	–3 dB chrominance bandwidth	COMB mode; around f <sub>SC</sub> ; note 2	1.5	–	–	MHz
		YC mode; base-band	10	–	–	MHz
Δt <sub>(proc)(Y)</sub>	difference with luminance processing delay		–	0	20	ns
V <sub>DC</sub>	DC voltage level		–	1.5	–	V
S/N <sub>chrom</sub>	chrominance signal-to-noise ratio (0.7 V/V <sub>rms</sub> noise)	unweighted; f <sub>SC</sub> ± 0.3f <sub>SC</sub> ; note 2	56	–	–	dB
α <sub>ct</sub>	crosstalk between different inputs	0 to 5 MHz	–	–	–50	dB
f <sub>clk(res)(chrom)</sub>	residues of clock frequencies in the chrominance signal (V <sub>rms</sub> /0.7 V)	COMB mode; note 2				
		f = 4 × f <sub>SC</sub>	–	–	–30	dB
		f = 2 × f <sub>SC</sub>	–	–	–30	dB
		f = 1.33 × f <sub>SC</sub>	–	–	–40	dB
FSC <sub>res(YC)</sub>	FSC residue in YC mode (V <sub>rms</sub> /0.7 V)	f = f <sub>SC</sub> ; f <sub>SC</sub> at FSC input	–	–	–60	dB
		f = 2 × f <sub>SC</sub> ; 2 × f <sub>SC</sub> at FSC input; note 2	–	–	–60	dB
α <sub>ct</sub>	crosstalk suppression at vertical transient no-colour ↔ colour [0.7 V/V (p-p)]	vertical transition active video ↔ vertical blanking; note 6 and Fig.5	26	–	–	dB

Integrated NTSC comb filter

TDA9183

SYMBOL	PARAMETER	CONDITIONS	MIN.	TYP.	MAX.	UNIT
SUP <sub>comb(chrom)</sub>	suppression (comb depth) with respect to chrominance band pass at $f = f_{SC}$	COMB mode; note 2 and Fig.7 $f = \frac{227}{227.5} \times f_{SC}$	30	–	–	dB
		$f = \frac{227 - 59}{227.5} \times f_{SC}$	30	–	–	dB
		$f = \frac{227 + 59}{227.5} \times f_{SC}$	30	–	–	dB
R <sub>o</sub>	output resistance		–	–	500	Ω
Z <sub>L</sub>	load impedance		–	–	15	pF

Notes

1. The pulse should fall inside the line-blanking interval, after the rising edge of the synchronizing pulse.
2.  $f_{SC}$  = colour subcarrier frequency;  $f_{SC} = 3.579545$  MHz for the NTSC M system.
3. With respect to 227.5 colour subcarrier periods (equals 63.556 μs) due to 1H delay in the comb filter.
4. With respect to the voltage level during clamping.
5. Test signal for NTSC M: 100% amplitude FCC multi-burst (see Fig.4).
6. Test signal for NTSC M: 100% white 75% amplitude FCC colour bar.

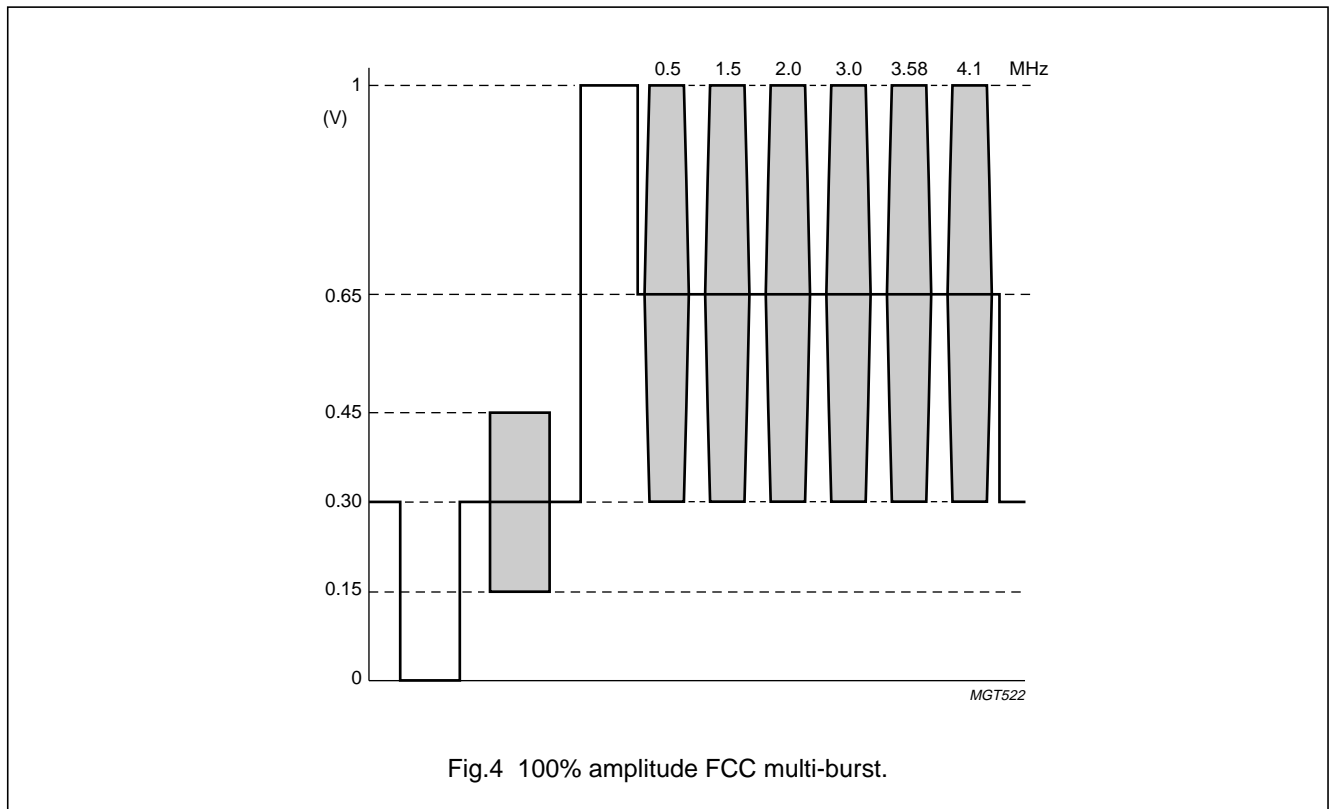

Fig.4 100% amplitude FCC multi-burst.

Integrated NTSC comb filter

TDA9183

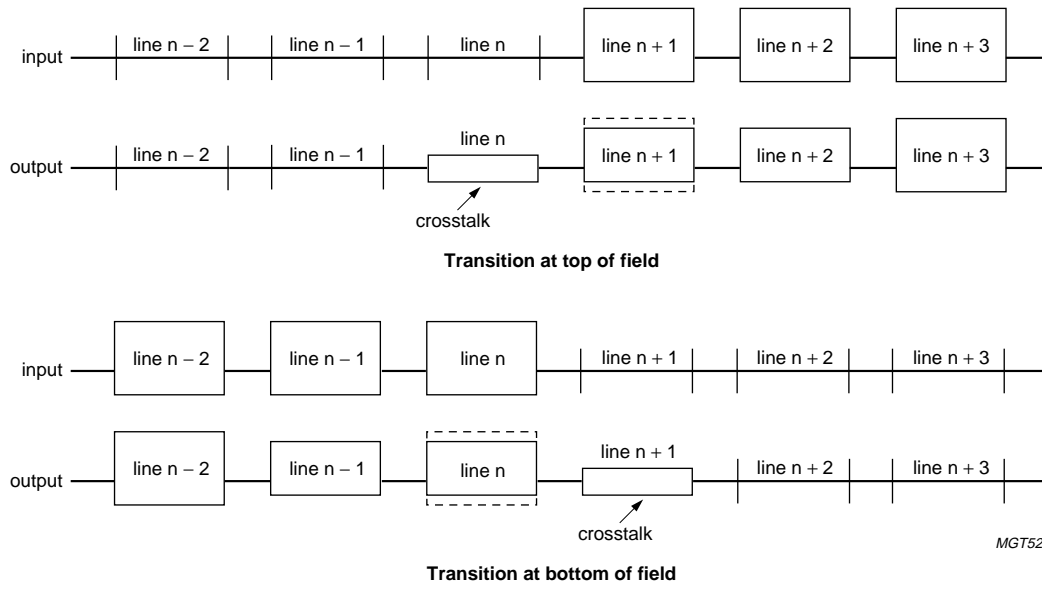

Fig.5 Vertical transitions active video  $\leftrightarrow$  vertical blanking from line to line (NTSC system).

Integrated NTSC comb filter

TDA9183

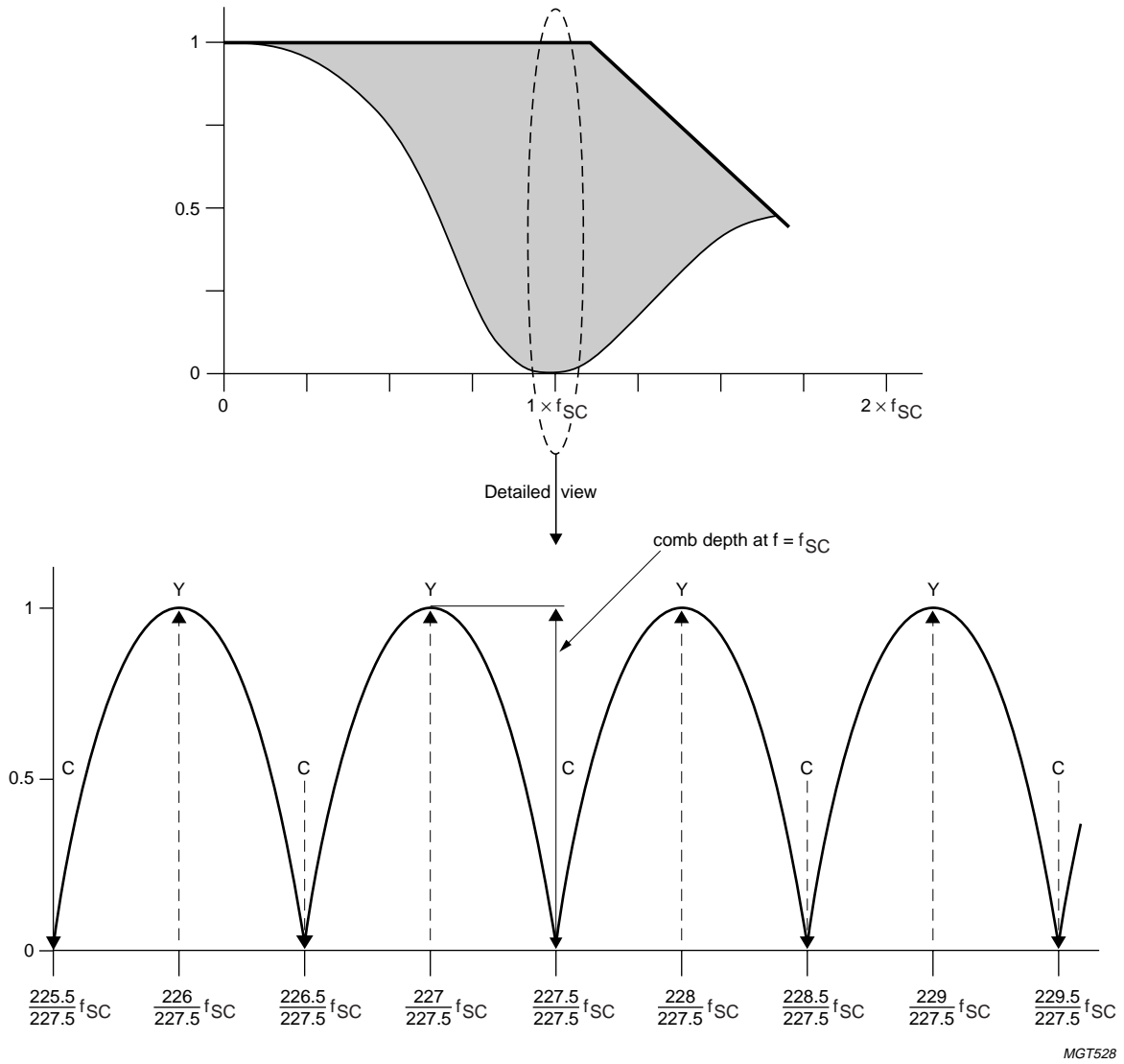

Fig.6 Luminance transfer characteristic (NTSC M system).

Integrated NTSC comb filter

TDA9183

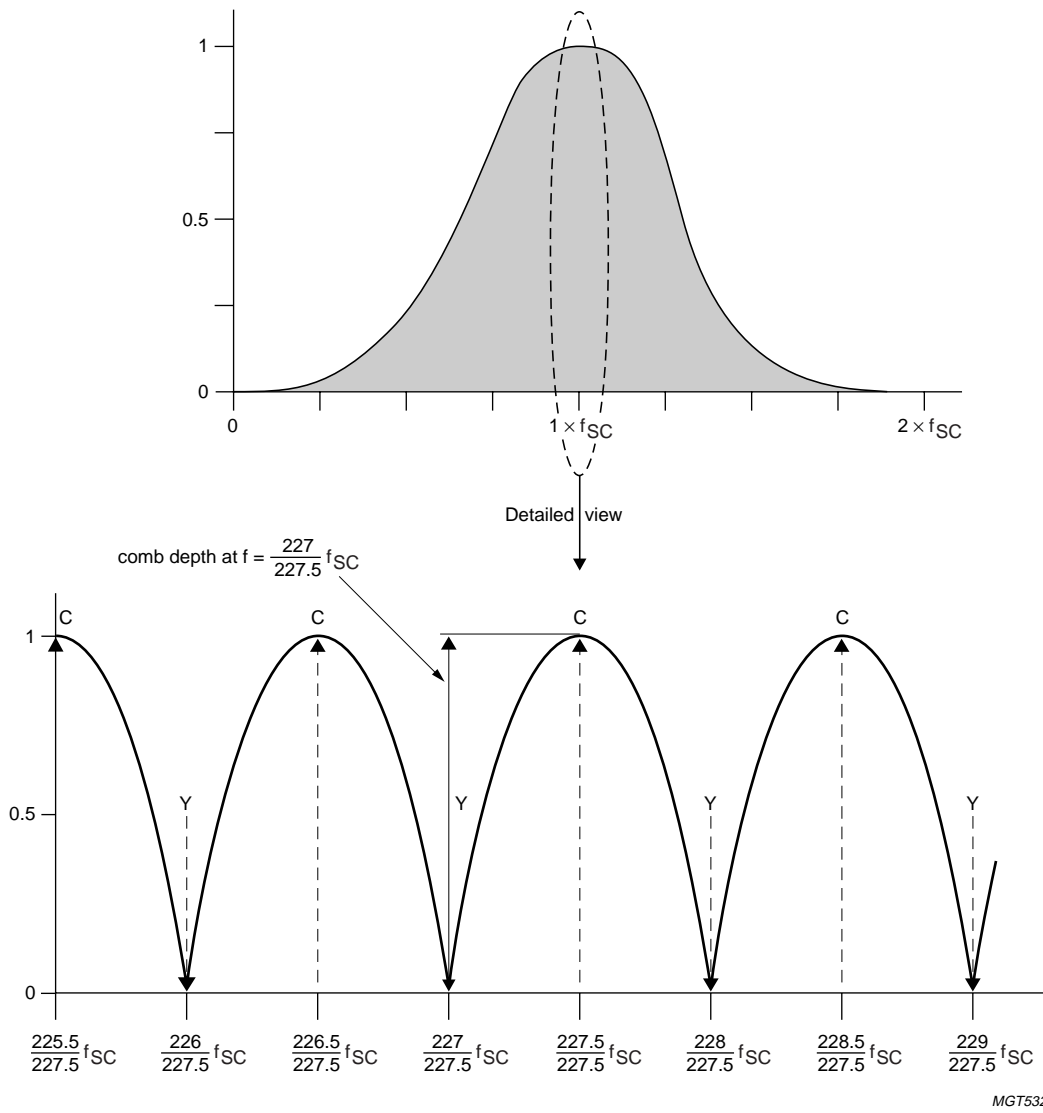

Fig.7 Chrominance transfer characteristic (NTSC M system).

Integrated NTSC comb filter

TDA9183

APPLICATION INFORMATION

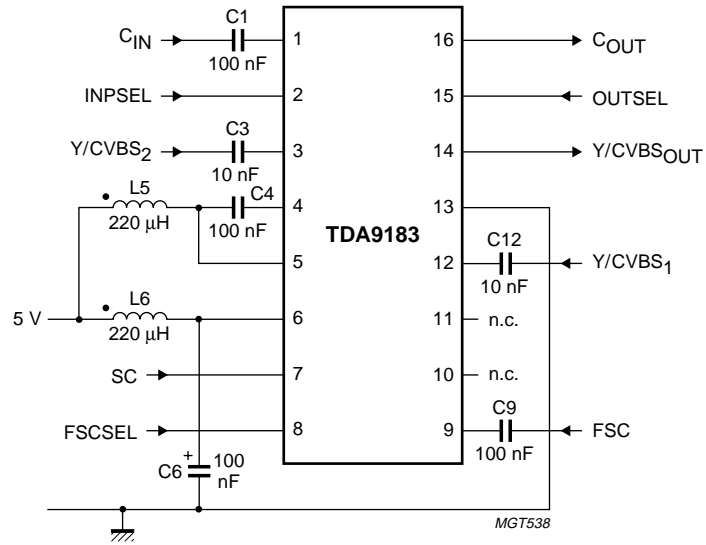

Fig.8 Application diagram.

Integrated NTSC comb filter

TDA9183

PACKAGE OUTLINES

DIP16: plastic dual in-line package; 16 leads (300 mil)

SOT38-4

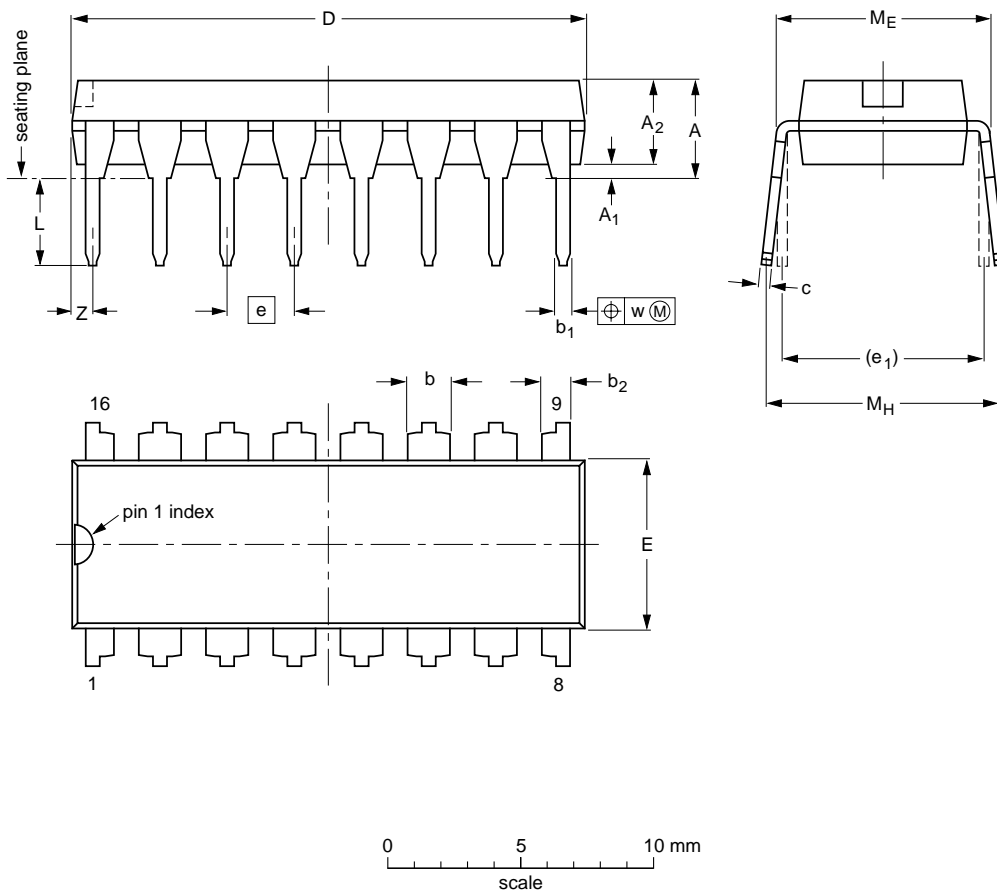

DIMENSIONS (inch dimensions are derived from the original mm dimensions)

UNIT	A max.	A <sub>1</sub> min.	A <sub>2</sub> max.	b	b <sub>1</sub>	b <sub>2</sub>	c	D <sup>(1)</sup>	E <sup>(1)</sup>	e	e <sub>1</sub>	L	M <sub>E</sub>	M <sub>H</sub>	w	Z <sup>(1)</sup> max.
mm	4.2	0.51	3.2	1.73 1.30	0.53 0.38	1.25 0.85	0.36 0.23	19.50 18.55	6.48 6.20	2.54	7.62	3.60 3.05	8.25 7.80	10.0 8.3	0.254	0.76
inches	0.17	0.020	0.13	0.068 0.051	0.021 0.015	0.049 0.033	0.014 0.009	0.77 0.73	0.26 0.24	0.10	0.30	0.14 0.12	0.32 0.31	0.39 0.33	0.01	0.030

Note

1. Plastic or metal protrusions of 0.25 mm maximum per side are not included.

OUTLINE VERSION	REFERENCES				EUROPEAN PROJECTION	ISSUE DATE
	IEC	JEDEC	EIAJ			
SOT38-4						92-11-17 95-01-14



Integrated NTSC comb filter

TDA9183

SO16: plastic small outline package; 16 leads; body width 7.5 mm

SOT162-1

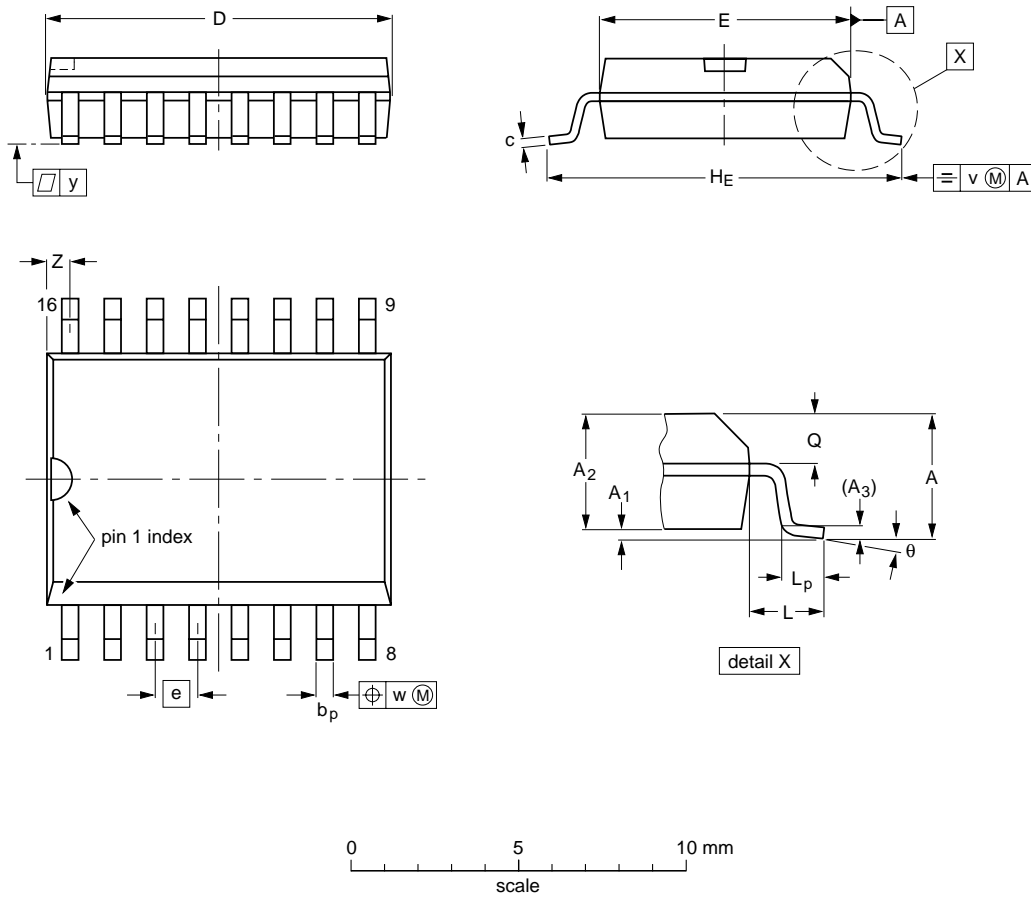

DIMENSIONS (inch dimensions are derived from the original mm dimensions)

UNIT	A max.	A <sub>1</sub>	A <sub>2</sub>	A <sub>3</sub>	b <sub>p</sub>	c	D <sup>(1)</sup>	E <sup>(1)</sup>	e	H <sub>E</sub>	L	L <sub>p</sub>	Q	v	w	y	z <sup>(1)</sup>	θ
mm	2.65	0.30 0.10	2.45 2.25	0.25	0.49 0.36	0.32 0.23	10.5 10.1	7.6 7.4	1.27	10.65 10.00	1.4	1.1 0.4	1.1 1.0	0.25	0.25	0.1	0.9 0.4	8° 0°
inches	0.10	0.012 0.004	0.096 0.089	0.01	0.019 0.014	0.013 0.009	0.41 0.40	0.30 0.29	0.050	0.419 0.394	0.055	0.043 0.016	0.043 0.039	0.01	0.01	0.004	0.035 0.016	

Note

1. Plastic or metal protrusions of 0.15 mm maximum per side are not included.

OUTLINE VERSION	REFERENCES				EUROPEAN PROJECTION	ISSUE DATE
	IEC	JEDEC	EIAJ			
SOT162-1	075E03	MS-013				97-05-22 99-12-27

## Integrated NTSC comb filter

TDA9183

### SOLDERING

#### Introduction

This text gives a very brief insight to a complex technology. A more in-depth account of soldering ICs can be found in our *"Data Handbook IC26; Integrated Circuit Packages"* (document order number 9398 652 90011).

There is no soldering method that is ideal for all IC packages. Wave soldering is often preferred when through-hole and surface mount components are mixed on one printed-circuit board. Wave soldering can still be used for certain surface mount ICs, but it is not suitable for fine pitch SMDs. In these situations reflow soldering is recommended.

#### Through-hole mount packages

##### SOLDERING BY DIPPING OR BY SOLDER WAVE

The maximum permissible temperature of the solder is 260 °C; solder at this temperature must not be in contact with the joints for more than 5 seconds. The total contact time of successive solder waves must not exceed 5 seconds.

The device may be mounted up to the seating plane, but the temperature of the plastic body must not exceed the specified maximum storage temperature ( $T_{stg(max)}$ ). If the printed-circuit board has been pre-heated, forced cooling may be necessary immediately after soldering to keep the temperature within the permissible limit.

##### MANUAL SOLDERING

Apply the soldering iron (24 V or less) to the lead(s) of the package, either below the seating plane or not more than 2 mm above it. If the temperature of the soldering iron bit is less than 300 °C it may remain in contact for up to 10 seconds. If the bit temperature is between 300 and 400 °C, contact may be up to 5 seconds.

#### Surface mount packages

##### REFLOW SOLDERING

Reflow soldering requires solder paste (a suspension of fine solder particles, flux and binding agent) to be applied to the printed-circuit board by screen printing, stencilling or pressure-syringe dispensing before package placement.

Several methods exist for reflowing; for example, convection or convection/infrared heating in a conveyor type oven. Throughput times (preheating, soldering and cooling) vary between 100 and 200 seconds depending on heating method.

Typical reflow peak temperatures range from 215 to 250 °C. The top-surface temperature of the packages should preferably be kept below 220 °C for thick/large packages, and below 235 °C for small/thin packages.

##### WAVE SOLDERING

Conventional single wave soldering is not recommended for surface mount devices (SMDs) or printed-circuit boards with a high component density, as solder bridging and non-wetting can present major problems.

To overcome these problems the double-wave soldering method was specifically developed.

If wave soldering is used the following conditions must be observed for optimal results:

- Use a double-wave soldering method comprising a turbulent wave with high upward pressure followed by a smooth laminar wave.
- For packages with leads on two sides and a pitch (e):
  - larger than or equal to 1.27 mm, the footprint longitudinal axis is **preferred** to be parallel to the transport direction of the printed-circuit board;
  - smaller than 1.27 mm, the footprint longitudinal axis **must** be parallel to the transport direction of the printed-circuit board.

The footprint must incorporate solder thieves at the downstream end.

- For packages with leads on four sides, the footprint must be placed at a 45° angle to the transport direction of the printed-circuit board. The footprint must incorporate solder thieves downstream and at the side corners.

During placement and before soldering, the package must be fixed with a droplet of adhesive. The adhesive can be applied by screen printing, pin transfer or syringe dispensing. The package can be soldered after the adhesive is cured.

Typical dwell time is 4 seconds at 250 °C.

A mildly-activated flux will eliminate the need for removal of corrosive residues in most applications.

##### MANUAL SOLDERING

Fix the component by first soldering two diagonally-opposite end leads. Use a low voltage (24 V or less) soldering iron applied to the flat part of the lead. Contact time must be limited to 10 seconds at up to 300 °C. When using a dedicated tool, all other leads can be soldered in one operation within 2 to 5 seconds between 270 and 320 °C.

## Integrated NTSC comb filter

TDA9183

## Suitability of IC packages for wave, reflow and dipping soldering methods

MOUNTING	PACKAGE	SOLDERING METHOD		
		WAVE	REFLOW <sup>(1)</sup>	DIPPING
Through-hole mount	DBS, DIP, HDIP, SDIP, SIL	suitable <sup>(2)</sup>	–	suitable
Surface mount	BGA, LFBGA, SQFP, TFBGA	not suitable	suitable	–
	HBCC, HLQFP, HSQFP, HSOP, HTQFP, HTSSOP, SMS	not suitable <sup>(3)</sup>	suitable	–
	PLCC <sup>(4)</sup> , SO, SOJ	suitable	suitable	–
	LQFP, QFP, TQFP	not recommended <sup>(4)(5)</sup>	suitable	–
	SSOP, TSSOP, VSO	not recommended <sup>(6)</sup>	suitable	–

## Notes

- All surface mount (SMD) packages are moisture sensitive. Depending upon the moisture content, the maximum temperature (with respect to time) and body size of the package, there is a risk that internal or external package cracks may occur due to vaporization of the moisture in them (the so called popcorn effect). For details, refer to the Drypack information in the “*Data Handbook IC26; Integrated Circuit Packages; Section: Packing Methods*”.
- For SDIP packages, the longitudinal axis must be parallel to the transport direction of the printed-circuit board.
- These packages are not suitable for wave soldering as a solder joint between the printed-circuit board and heatsink (at bottom version) can not be achieved, and as solder may stick to the heatsink (on top version).
- If wave soldering is considered, then the package must be placed at a 45° angle to the solder wave direction. The package footprint must incorporate solder thieves downstream and at the side corners.
- Wave soldering is only suitable for LQFP, QFP and TQFP packages with a pitch (e) equal to or larger than 0.8 mm; it is definitely not suitable for packages with a pitch (e) equal to or smaller than 0.65 mm.
- Wave soldering is only suitable for SSOP and TSSOP packages with a pitch (e) equal to or larger than 0.65 mm; it is definitely not suitable for packages with a pitch (e) equal to or smaller than 0.5 mm.

## Integrated NTSC comb filter

TDA9183

## DATA SHEET STATUS

DATA SHEET STATUS	PRODUCT STATUS	DEFINITIONS <sup>(1)</sup>
Objective specification	Development	This data sheet contains the design target or goal specifications for product development. Specification may change in any manner without notice.
Preliminary specification	Qualification	This data sheet contains preliminary data, and supplementary data will be published at a later date. Philips Semiconductors reserves the right to make changes at any time without notice in order to improve design and supply the best possible product.
Product specification	Production	This data sheet contains final specifications. Philips Semiconductors reserves the right to make changes at any time without notice in order to improve design and supply the best possible product.

## Note

1. Please consult the most recently issued data sheet before initiating or completing a design.

## DEFINITIONS

**Short-form specification** — The data in a short-form specification is extracted from a full data sheet with the same type number and title. For detailed information see the relevant data sheet or data handbook.

**Limiting values definition** — Limiting values given are in accordance with the Absolute Maximum Rating System (IEC 60134). Stress above one or more of the limiting values may cause permanent damage to the device. These are stress ratings only and operation of the device at these or at any other conditions above those given in the Characteristics sections of the specification is not implied. Exposure to limiting values for extended periods may affect device reliability.

**Application information** — Applications that are described herein for any of these products are for illustrative purposes only. Philips Semiconductors make no representation or warranty that such applications will be suitable for the specified use without further testing or modification.

## DISCLAIMERS

**Life support applications** — These products are not designed for use in life support appliances, devices, or systems where malfunction of these products can reasonably be expected to result in personal injury. Philips Semiconductors customers using or selling these products for use in such applications do so at their own risk and agree to fully indemnify Philips Semiconductors for any damages resulting from such application.

**Right to make changes** — Philips Semiconductors reserves the right to make changes, without notice, in the products, including circuits, standard cells, and/or software, described or contained herein in order to improve design and/or performance. Philips Semiconductors assumes no responsibility or liability for the use of any of these products, conveys no licence or title under any patent, copyright, or mask work right to these products, and makes no representations or warranties that these products are free from patent, copyright, or mask work right infringement, unless otherwise specified.

Integrated NTSC comb filter

TDA9183

---

**NOTES**

Integrated NTSC comb filter

TDA9183

---

**NOTES**

Integrated NTSC comb filter

TDA9183

---

**NOTES**

# Philips Semiconductors – a worldwide company

**Argentina:** see South America

**Australia:** 3 Figtree Drive, HOMEBUSH, NSW 2140,  
Tel. +61 2 9704 8141, Fax. +61 2 9704 8139

**Austria:** Computerstr. 6, A-1101 WIEN, P.O. Box 213,  
Tel. +43 1 60 101 1248, Fax. +43 1 60 101 1210

**Belarus:** Hotel Minsk Business Center, Bld. 3, r. 1211, Volodarski Str. 6,  
220050 MINSK, Tel. +375 172 20 0733, Fax. +375 172 20 0773

**Belgium:** see The Netherlands

**Brazil:** see South America

**Bulgaria:** Philips Bulgaria Ltd., Energoproject, 15th floor,  
51 James Bourchier Blvd., 1407 SOFIA,  
Tel. +359 2 68 9211, Fax. +359 2 68 9102

**Canada:** PHILIPS SEMICONDUCTORS/COMPONENTS,  
Tel. +1 800 234 7381, Fax. +1 800 943 0087

**China/Hong Kong:** 501 Hong Kong Industrial Technology Centre,  
72 Tat Chee Avenue, Kowloon Tong, HONG KONG,  
Tel. +852 2319 7888, Fax. +852 2319 7700

**Colombia:** see South America

**Czech Republic:** see Austria

**Denmark:** Sydhavnsgade 23, 1780 COPENHAGEN V,  
Tel. +45 33 29 3333, Fax. +45 33 29 3905

**Finland:** Sinikalliontie 3, FIN-02630 ESPOO,  
Tel. +358 9 615 800, Fax. +358 9 6158 0920

**France:** 51 Rue Carnot, BP317, 92156 SURESNES Cedex,  
Tel. +33 1 4099 6161, Fax. +33 1 4099 6427

**Germany:** Hammerbrookstraße 69, D-20097 HAMBURG,  
Tel. +49 40 2353 60, Fax. +49 40 2353 6300

**Hungary:** see Austria

**India:** Philips INDIA Ltd, Band Box Building, 2nd floor,  
254-D, Dr. Annie Besant Road, Worli, MUMBAI 400 025,  
Tel. +91 22 493 8541, Fax. +91 22 493 0966

**Indonesia:** PT Philips Development Corporation, Semiconductors Division,  
Gedung Philips, Jl. Buncit Raya Kav.99-100, JAKARTA 12510,  
Tel. +62 21 794 0040 ext. 2501, Fax. +62 21 794 0080

**Ireland:** Newstead, Clonskeagh, DUBLIN 14,  
Tel. +353 1 7640 000, Fax. +353 1 7640 200

**Israel:** RAPAC Electronics, 7 Kehilat Saloniki St, PO Box 18053,  
TEL AVIV 61180, Tel. +972 3 645 0444, Fax. +972 3 649 1007

**Italy:** PHILIPS SEMICONDUCTORS, Via Casati, 23 - 20052 MONZA (MI),  
Tel. +39 039 203 6838, Fax +39 039 203 6800

**Japan:** Philips Bldg 13-37, Kohnan 2-chome, Minato-ku,  
TOKYO 108-8507, Tel. +81 3 3740 5130, Fax. +81 3 3740 5057

**Korea:** Philips House, 260-199 Itaewon-dong, Yongsan-ku, SEOUL,  
Tel. +82 2 709 1412, Fax. +82 2 709 1415

**Malaysia:** No. 76 Jalan Universiti, 46200 PETALING JAYA, SELANGOR,  
Tel. +60 3 750 5214, Fax. +60 3 757 4880

**Mexico:** 5900 Gateway East, Suite 200, EL PASO, TEXAS 79905,  
Tel. +9-5 800 234 7381, Fax +9-5 800 943 0087

**Middle East:** see Italy

**Netherlands:** Postbus 90050, 5600 PB EINDHOVEN, Bldg. VB,  
Tel. +31 40 27 82785, Fax. +31 40 27 88399

**New Zealand:** 2 Wagener Place, C.P.O. Box 1041, AUCKLAND,  
Tel. +64 9 849 4160, Fax. +64 9 849 7811

**Norway:** Box 1, Manglerud 0612, OSLO,  
Tel. +47 22 74 8000, Fax. +47 22 74 8341

**Pakistan:** see Singapore

**Philippines:** Philips Semiconductors Philippines Inc.,  
106 Valero St. Salcedo Village, P.O. Box 2108 MCC, MAKATI,  
Metro MANILA, Tel. +63 2 816 6380, Fax. +63 2 817 3474

**Poland:** Al.Jerozolimskie 195 B, 02-222 WARSAW,  
Tel. +48 22 5710 000, Fax. +48 22 5710 001

**Portugal:** see Spain

**Romania:** see Italy

**Russia:** Philips Russia, Ul. Usatcheva 35A, 119048 MOSCOW,  
Tel. +7 095 755 6918, Fax. +7 095 755 6919

**Singapore:** Lorong 1, Toa Payoh, SINGAPORE 319762,  
Tel. +65 350 2538, Fax. +65 251 6500

**Slovakia:** see Austria

**Slovenia:** see Italy

**South Africa:** S.A. PHILIPS Pty Ltd., 195-215 Main Road Martindale,  
2092 JOHANNESBURG, P.O. Box 58088 Newville 2114,  
Tel. +27 11 471 5401, Fax. +27 11 471 5398

**South America:** Al. Vicente Pinzon, 173, 6th floor,  
04547-130 SÃO PAULO, SP, Brazil,  
Tel. +55 11 821 2333, Fax. +55 11 821 2382

**Spain:** Balmes 22, 08007 BARCELONA,  
Tel. +34 93 301 6312, Fax. +34 93 301 4107

**Sweden:** Kottbygatan 7, Akalla, S-16485 STOCKHOLM,  
Tel. +46 8 5985 2000, Fax. +46 8 5985 2745

**Switzerland:** Allmendstrasse 140, CH-8027 ZÜRICH,  
Tel. +41 1 488 2741 Fax. +41 1 488 3263

**Taiwan:** Philips Semiconductors, 5F, No. 96, Chien Kuo N. Rd., Sec. 1,  
TAIPEI, Taiwan Tel. +886 2 2134 2451, Fax. +886 2 2134 2874

**Thailand:** PHILIPS ELECTRONICS (THAILAND) Ltd.,  
60/14 MOO 11, Bangna Trad Road KM. 3, Bagna, BANGKOK 10260,  
Tel. +66 2 361 7910, Fax. +66 2 398 3447

**Turkey:** Yukari Dudullu, Org. San. Blg., 2.Cad. Nr. 28 81260 Umraniye,  
ISTANBUL, Tel. +90 216 522 1500, Fax. +90 216 522 1813

**Ukraine:** PHILIPS UKRAINE, 4 Patrice Lumumba str., Building B, Floor 7,  
252042 KIEV, Tel. +380 44 264 2776, Fax. +380 44 268 0461

**United Kingdom:** Philips Semiconductors Ltd., 276 Bath Road, Hayes,  
MIDDLESEX UB3 5BX, Tel. +44 208 730 5000, Fax. +44 208 754 8421

**United States:** 811 East Arques Avenue, SUNNYVALE, CA 94088-3409,  
Tel. +1 800 234 7381, Fax. +1 800 943 0087

**Uruguay:** see South America

**Vietnam:** see Singapore

**Yugoslavia:** PHILIPS, Trg N. Pasica 5/v, 11000 BEOGRAD,  
Tel. +381 11 3341 299, Fax.+381 11 3342 553

**For all other countries apply to:** Philips Semiconductors,  
Marketing Communications, Building BE-p, P.O. Box 218, 5600 MD EINDHOVEN,  
The Netherlands, Fax. +31 40 27 24825

**Internet:** <http://www.semiconductors.philips.com>

© Philips Electronics N.V. 2000

SCA 70

All rights are reserved. Reproduction in whole or in part is prohibited without the prior written consent of the copyright owner.

The information presented in this document does not form part of any quotation or contract, is believed to be accurate and reliable and may be changed without notice. No liability will be accepted by the publisher for any consequence of its use. Publication thereof does not convey nor imply any license under patent- or other industrial or intellectual property rights.

Printed in The Netherlands

753504/25/02/pp24

Date of release: 2000 Nov 30

Document order number: 9397 750 07804

*Let's make things better.*

**Philips  
Semiconductors**



**PHILIPS**