

TD62705P, TD62705F, TD62706P, TD62706F

6CH HIGH-VOLTAGE SOURCE DRIVER

The TD62705P, TD62705F and TD62706P, TD62706F are comprised of six source current transistor array. These drivers are specifically designed for fluorescent display applications. For proper operation, the substrate (SUB) must be connected to the most negative voltage.

FEATURES

- High output voltage : $V_{CC} - V_{OUT} = 60V$ (Min.)
- Output current (single output) : $I_{OUT} = -50mA$ (Max.)
- Input compatible with various types of logic
 TD62705P, TD62705F $R_{IN} = 47k\Omega$: 6~25V PMOS, CMOS
 TD62706P, TD62706F $R_{IN} = 10k\Omega$: TTL, 5V CMOS
- Package type-P : DIP-16 pin
- Package type-F : SOP-16 pin

PIN CONNECTION (TOP VIEW)

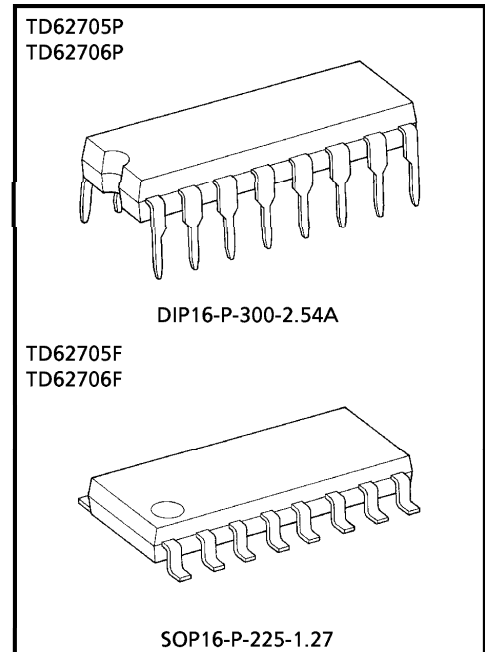
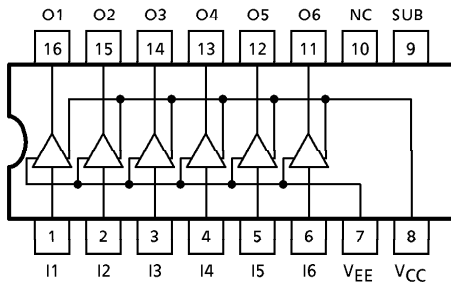

Weight
 DIP16-P-300-2.54A : 1.11g (Typ.)
 SOP16-P-225-1.27 : 0.16g (Typ.)

SCHEMATICS (EACH DRIVER)

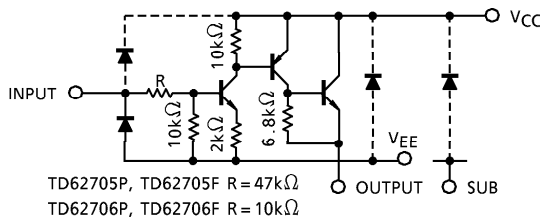

(Note) The input and output parasitic diodes cannot be used as clamp diodes.

961001EBA2

● TOSHIBA is continually working to improve the quality and the reliability of its products. Nevertheless, semiconductor devices in general can malfunction or fail due to their inherent electrical sensitivity and vulnerability to physical stress. It is the responsibility of the buyer, when utilizing TOSHIBA products, to observe standards of safety, and to avoid situations in which a malfunction or failure of a TOSHIBA product could cause loss of human life, bodily injury or damage to property. In developing your designs, please ensure that TOSHIBA products are used within specified operating ranges as set forth in the most recent products specifications. Also, please keep in mind the precautions and conditions set forth in the TOSHIBA Semiconductor Reliability Handbook.

● The products described in this document are subject to foreign exchange and foreign trade control laws.

● The information contained herein is presented only as a guide for the applications of our products. No responsibility is assumed by TOSHIBA CORPORATION for any infringements of intellectual property or other rights of the third parties which may result from its use. No license is granted by implication or otherwise under any intellectual property or other rights of TOSHIBA CORPORATION or others.

● The information contained herein is subject to change without notice.

MAXIMUM RATINGS (Ta = 25°C)

CHARACTERISTIC	SYMBOL	RATING	UNIT	
Supply Voltage	V _{CC-V_{EE}}	30	V	
	V _{CC-V_{SUB}}	60		
Output Voltage	V _{CC-V_{OUT}}	- 60	V	
Input Voltage	V _{IN-V_{EE}}	V _{CC - V_{EE}}	V	
Output Current	I _{OUT}	- 50	mA / ch	
Input Current	I _{IN}	± 10	mA	
Power Dissipation	P F	P _D (Note 2)	1.0	W
			0.625 (Note 1)	
Operating Temperature	T _{opr}	- 40~85	°C	
Storage Temperature	T _{stg}	- 55~150	°C	

(Note 1) On Glass Epoxy PCB (30 × 30 × 1.6mm Cu 50%)

(Note 2) Delated above 25°C in the proportion of 8.0mw/°C (P Type), 5.0mw/°C (F Type).

RECOMMENDED OPERATING CONDITIONS (Ta = - 40~85°C)

CHARACTERISTIC	SYMBOL	CONDITION	MIN.	TYP.	MAX.	UNIT	
Supply Voltage	TD62705P TD62705F	V _{CC}	V _{EE} = 0V	6.0	—	25	V
				4.5	—	25	
	TD62706P TD62706F	V _{SUB}	V _{CC} = 0V	V _{OUT}	—	- 55	V
Output Voltage	V _{OUT}	V _{CC} = 0V	0	—	- 55	V	
Output Current	I _{OUT}	—	0	—	- 40	mA / ch	
Input Voltage	TD62705P TD62705F	V _{IN}	V _{EE} = 0V, V _{CC} = 25V	0	—	25	V
				0	—	7	
Power Dissipation	P	P _D	—	—	0.36	W	
	F		On PCB (Note)	—	—		0.325

(Note) On Glass Epoxy PCB (30 × 30 × 1.6mm, Cu 50%)

ELECTRICAL CHARACTERISTICS (Ta = 25°C)

CHARACTERISTIC		SYMBOL	TEST CIR-CUIT	TEST CONDITION	MIN.	TYP.	MAX.	UNIT	
Input Voltage	"H" Level	TD62705P	V _{IH}	1	V _{EE} = 0V	6.0	—	—	V
		TD62705F			V _{EE} = 0V	2.2	—	—	
	"L" Level	TD62705P	V _{IL}	1	V _{EE} = 0V	—	—	2.2	
		TD62706P TD62706F			V _{EE} = 0V	—	—	0.8	
Input Current	"H" Level	TD62705P	I _{IH}	2	V _{EE} = 0V, V _{IN} = 6.0V	—	0.11	0.16	mA
		TD62705F			V _{EE} = 0V, V _{IN} = 2.4V	—	0.12	0.18	
	"L" Level	I _{IL}	2	V _{EE} = V _{IN} = 0V, V _{CC} = 25V	—	—	± 1	μA	
Output Leakage Current		I _{CEX}	3	V _{EE} = 0V, V _{CC} = 25V V _{IN} = V _{IL} MAX. I _{OUT} = - 30V	—	—	- 100	μA	
Collector-Emitter Saturation Voltage		V _{CE (sat)}	4	V _{EE} = 0V, V _{CC} = V _{CC} MIN. V _{IN} = V _{IH} MIN. I _{OUT} = - 40mA	—	—	V _{CC} - 2.5	V	
Supply Current (Output On)	TD62705P	I _{CC}	1	V _{EE} = 0V, V _{CC} = 25V V _{IN} = V _{IN} MAX. I _{OUT} = 0mA	—	—	32	mA	
	TD62706P TD62706F				—	—	25		
Turn-On Delay		t _{ON}	5	R _L = 1.4kΩ, C _L = 15pF	—	0.2	—	μs	
Turn-Off Delay		t _{OFF}			—	1.5	—	μs	

TEST CIRCUIT

1. V_{IH} , V_{IL} , I_{CC}

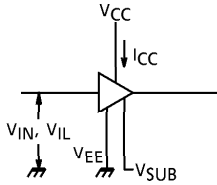

2. I_{IH} , I_{IL}

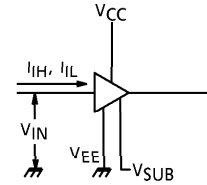

3. I_{CEX}

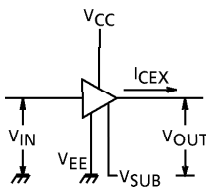

4. $V_{CE(sat)}$

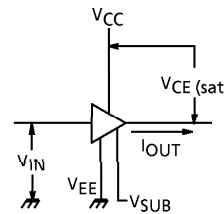

5. t_{ON} , t_{OFF}

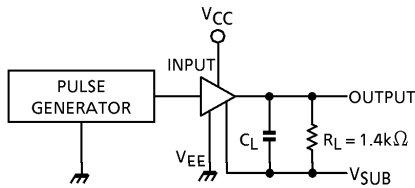

$C_L = 15\text{pF}$
(Includes probe and jig capacitance)

INPUT CONDITION

TYPE NAME	V_{IN}	V_{CC}	V_{SUB}
TD62705P, TD62705F	0-9V	25V	-30
TD62706P, TD62706F	0-3V	25V	-30

V_{IN} : Pulse Width $50\mu\text{s}$
Duty Cycle 50%
 $t_r \leq 5\text{ns}$
 $t_f \leq 10\text{ns}$

PRECAUTIONS for USING

Utmost care is necessary in the design of the output line, V_{CC} and GND (SUB, V_{EE}) line since IC may be destroyed due to short-circuit between outputs, air contamination fault, or fault by improper grounding.

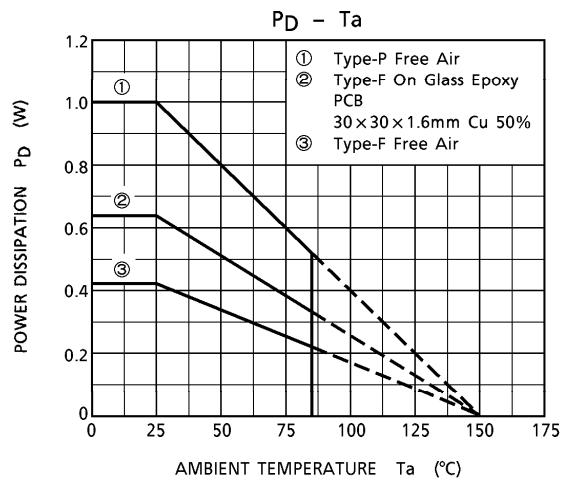
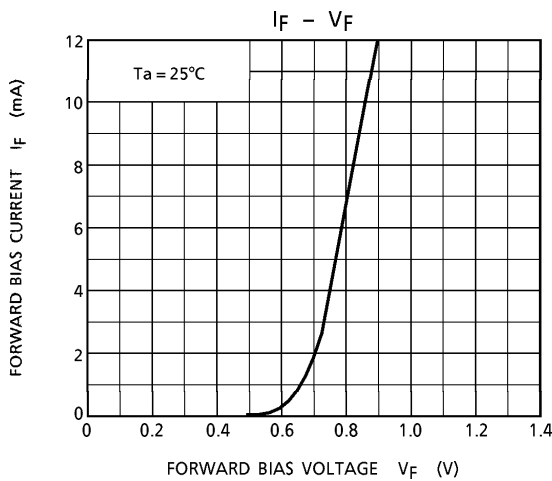
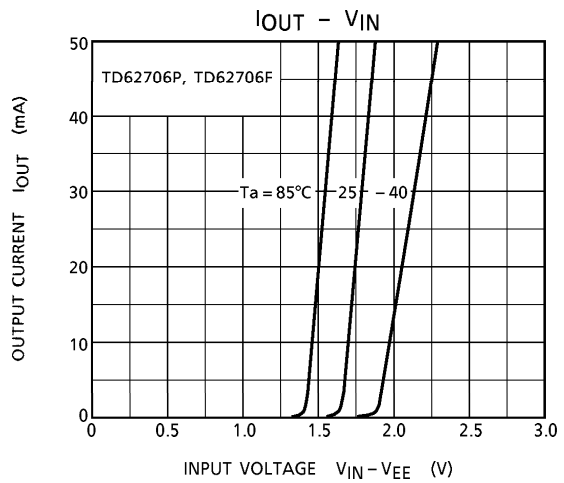
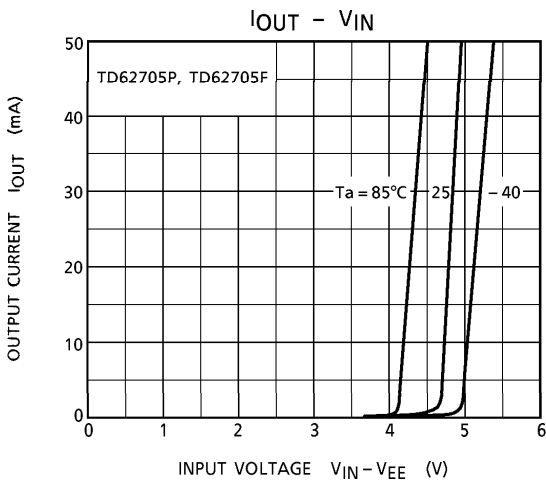
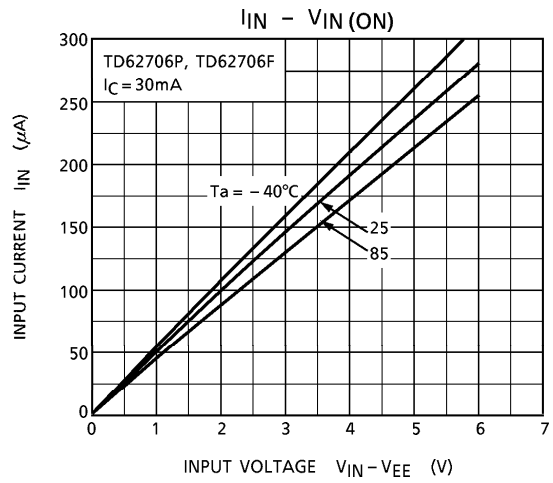
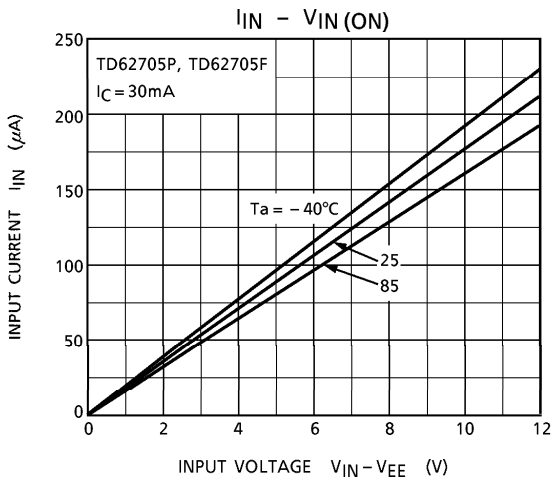

OUTLINE DRAWING
DIP16-P-300-2.54A

Unit : mm

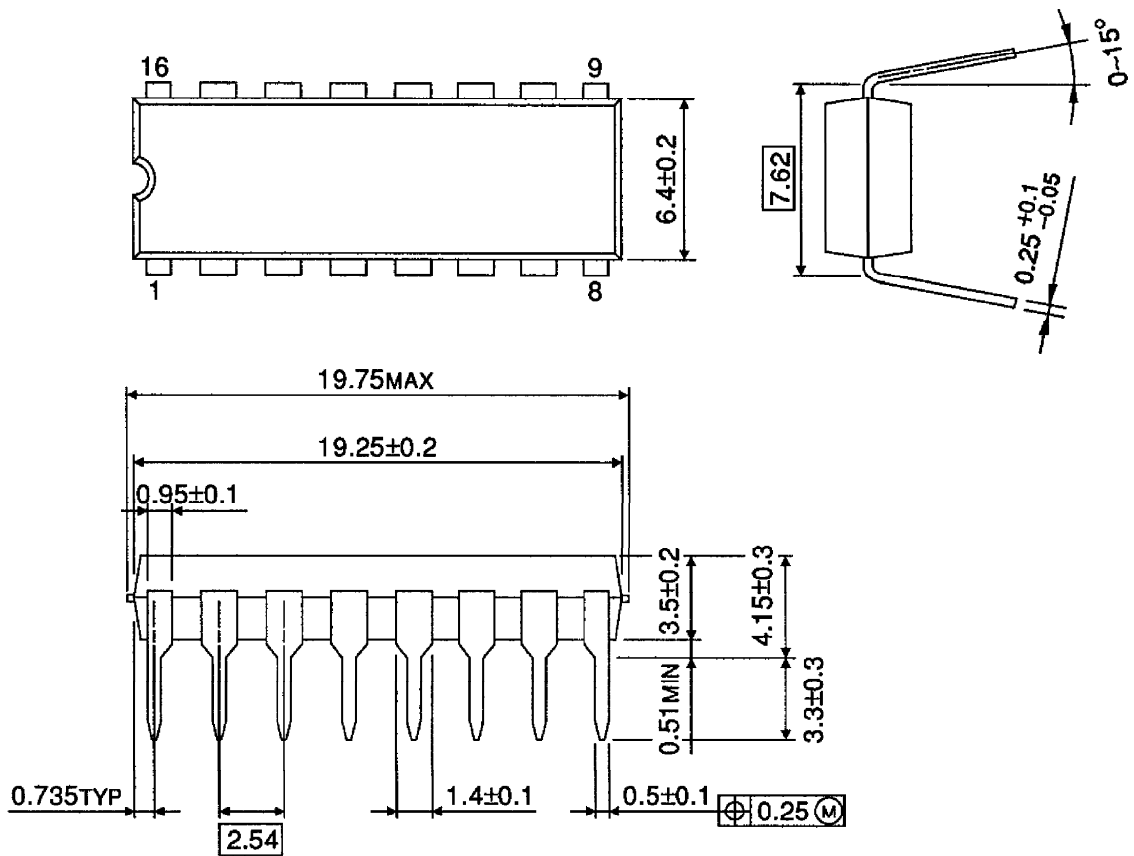

Weight : 1.11g (Typ.)

OUTLINE DRAWING
SOP16-P-225-1.27

Unit : mm

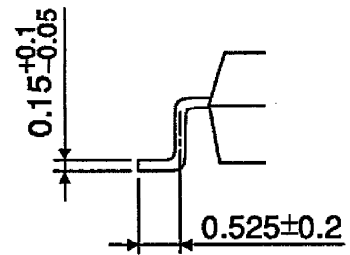
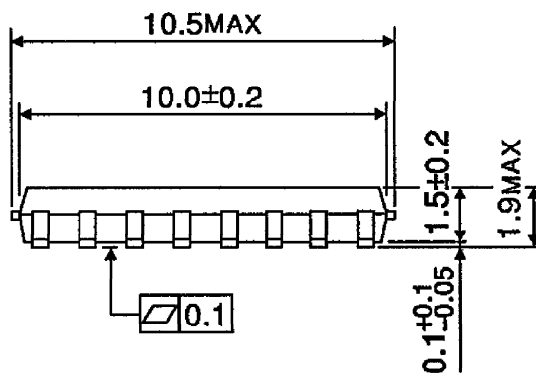
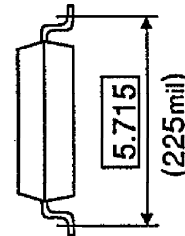
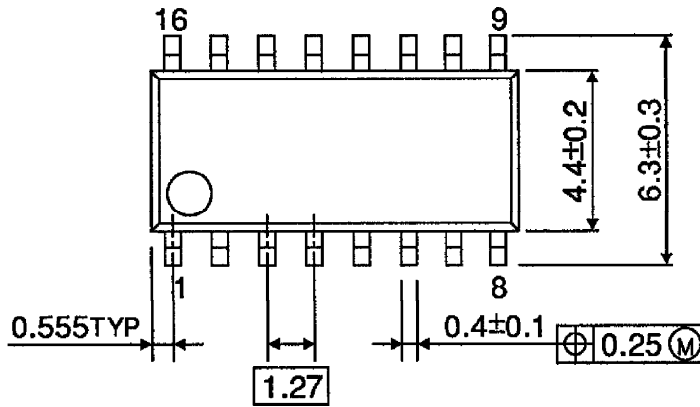

Weight : 0.16g (Typ.)