

PHOTO REFLECTOR WITH LENS

■ GENERAL DESCRIPTION

The NJL5165KL is small photo reflector of Deep Focal Distance and High Resolution. The NJL5165KL is composed of infrared LED, high sensitive Si-photo transistor and high resoluitive lens.

■ FEATURES

- Super minimature type.
- Detectable from near zero to 10 mm.
- High output current, high S/N ratio.
- Built-in visible light cut-off filter.

■ APPLICATIONS

- Detection of separated Rotational and moving product(various motors, audio controllers, CD plate, LD plate, etc.).
- Paper Detection of Facsimil & Copy machine.
- Paper Edge Detection
- Bar code reader. Card reader.

■ ABSOLUTE MAXIMUM RATINGS (Ta=25°C)

PARAMETER	SYMBOL	RATINGS	UNIT
Emitter			
Continous Forward Current	IF	50	mA
Pulse Forward Current	IFP	500(Note1)	mA
Continous Reverse Voltage	VR	6	V
Power Dissipation	PD	75	mW
Detector			
Collector-Emitter Voltage	VCEO	25	V
Emitter-Collector Voltage	VECO	6	V
Collector Current	IC	20	mA
Collector Power Dissipation	PC	75	mW
Coupled			
Total Power Dissipation	Ptot	100	mW
Operating Temperature	Topr	-20~+70	°C
Storage Temperature	Tstg	-30~+75	°C
Soldering Temperature	Tsol	260(Note2)	°C

(Note1):Pulsewidth ≤ 10μs, Duty Ratio 0.01

(Note2):5 sec, more than 1.5mm from body

■ ELECTRO-OPTICAL CHARACTERISTICS (Ta=25°C)

PARAMETER	SYMBOL	TEST CONDITION	MIN.	TYP.	MAX.	UNIT
Emitter						
Forward Voltage	VF	IF=15mA	—	—	1.5	V
Reverse Current	IR	VR=6V	—	—	1.0	μA
Capacitance	Ct	VR=0V, f=1MHz	—	25	—	pF
Detector						
Dark Current	ICEO	VCE=20V	—	—	100	nA
Collector-Emitter Voltage	VCEO	IC=100μA	25	—	—	V
Emitter-Collector Current	IECO	VECO=6V	—	—	100	μA
Coupled						
Output Current	IO	IF=15mA, VCE=5V, d=4.0mm	1000	—	5000	μA
Operating Dark Current	ICEOD	IF=15mA, VCE=5V	—	—	100	μA
Outpiut Current/Operating Dark Current	S/N	IF=15mA, VCE=5V, d=4.0mm	50	—	—	—
Rise time	tr	IF=15mA, VCE=5V, d=4.0mm, RL=1kΩ	—	20	—	μs
Fall Time	tr	IF=15mA, VCE=5V, d=4.0mm, RL=1kΩ	—	20	—	μs
peak output Distance	dlopeak	IF=15mA, VCE=5V	—	4.0	—	mm

■ OUTLINE(typ.) Unit:mm

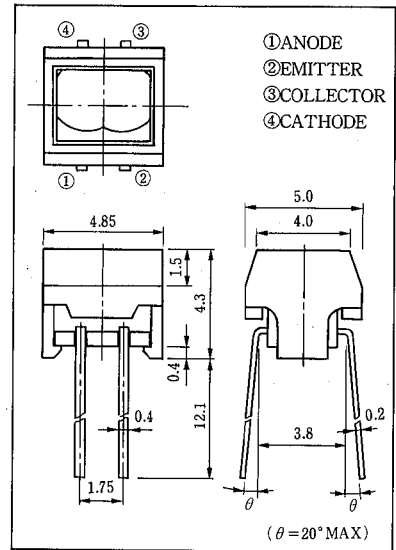

■ MEASURING SPECIFICATION FOR OUTPUT CURRENT

The output current can be measured when reflected at Aluminum Evaporation Surface

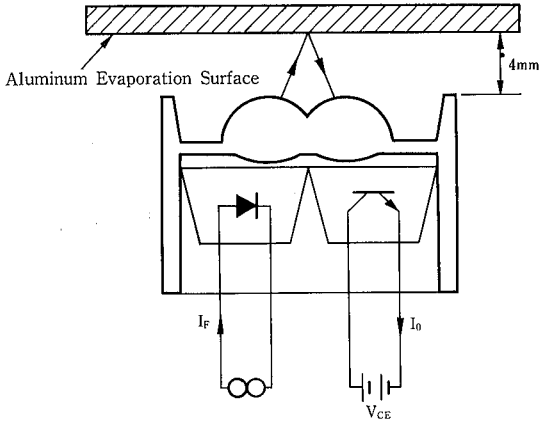

■ MEASURING CIRCUIT FOR OPERATING DARK CURRENT

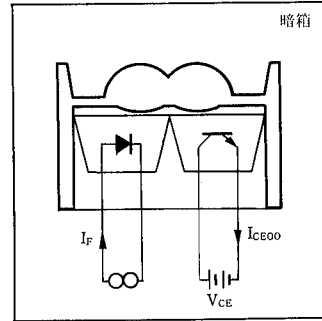

■ MEASURING CIRCUIT FOR RESPONSE TIME

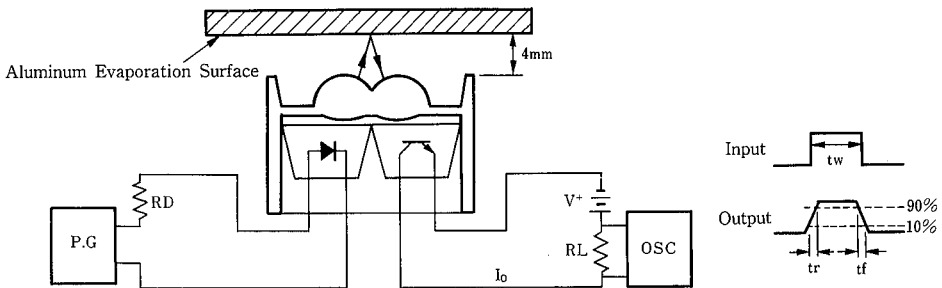

■ MAXIMUM RATING CURVES

Power Dissipation vs. Temperature

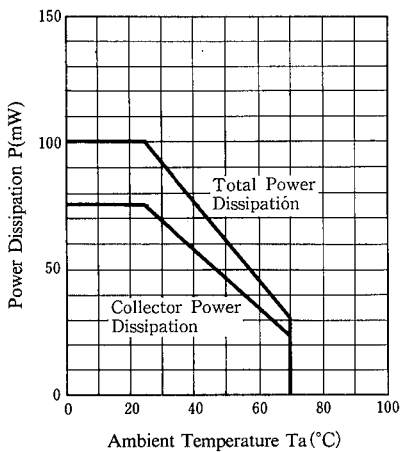

Forward Current vs. Temperature

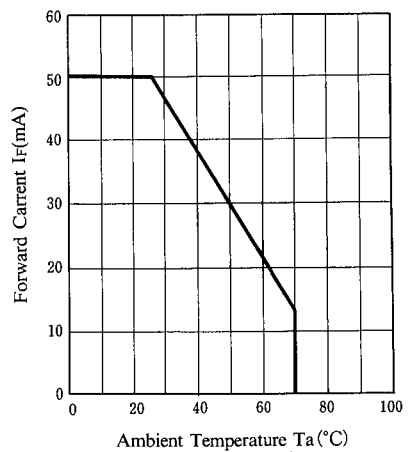

2

Pulse Forward Current vs. Duty Ratio

($T_a=25^\circ\text{C}$, $t_w=10\mu\text{s}$ max.)

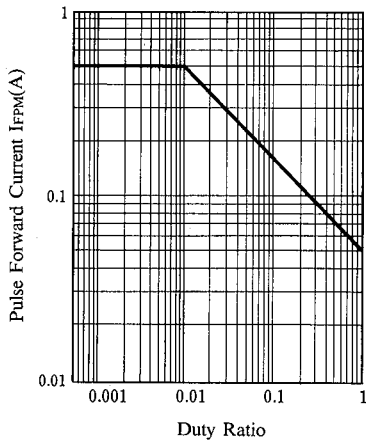

Pulse Width vs. Forward Current

($T_a=25^\circ\text{C}$, Duty Ratio 0.01 max.)

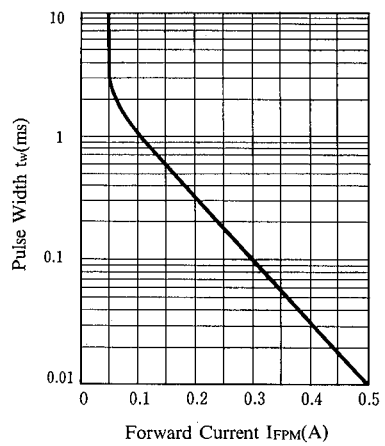

■ **TYPICAL CHARACTERISTICS**

Forward Current vs. Forward Voltage

($T_a=75, 50, 25, 0, -25^\circ\text{C}$)

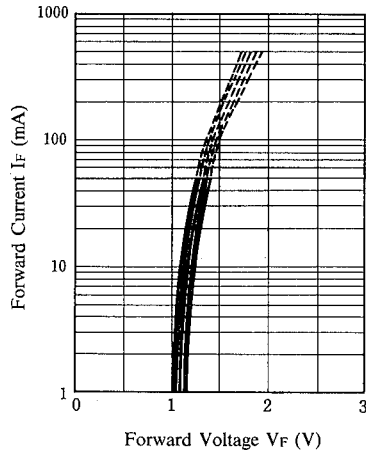

Dark Current vs. Temperature

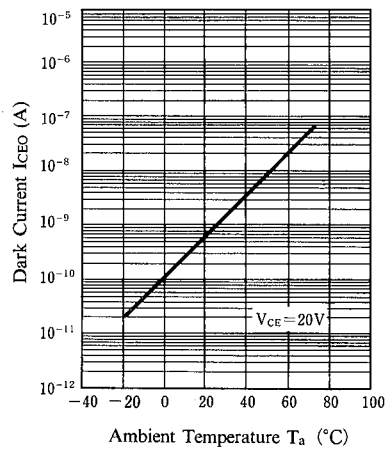

Output Current vs. Forward Current

Forward Current ($T_a=25^\circ\text{C}$)

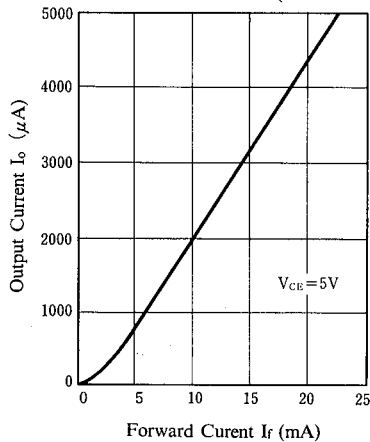

Output Current vs. Temperature

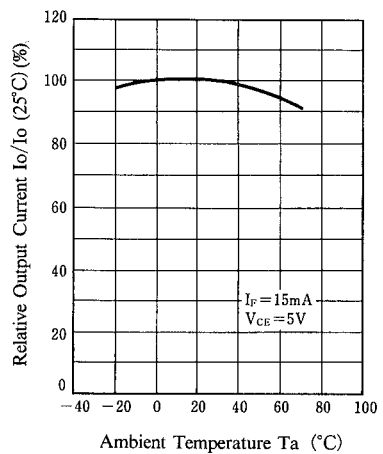

Operating Dark Current vs. Temperature

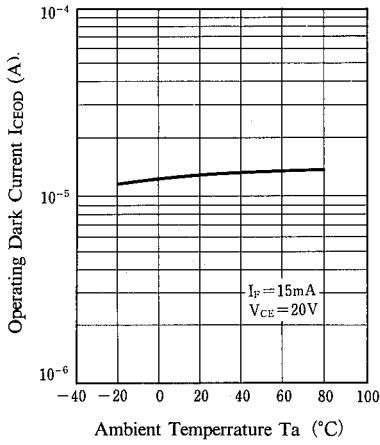

Output Characteristics (Ta=25°C)

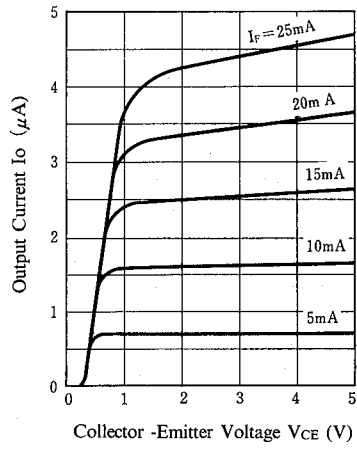

Vce Saturation (Ta=25°C)

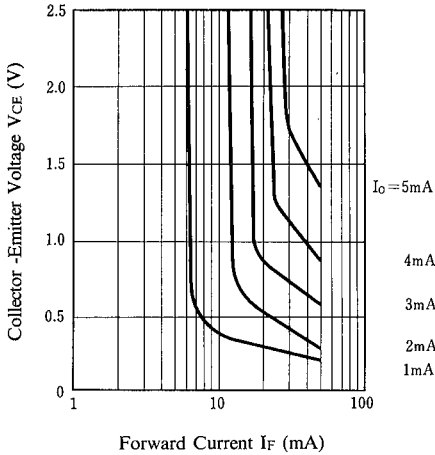

Spectral Response (Ta=25°C)

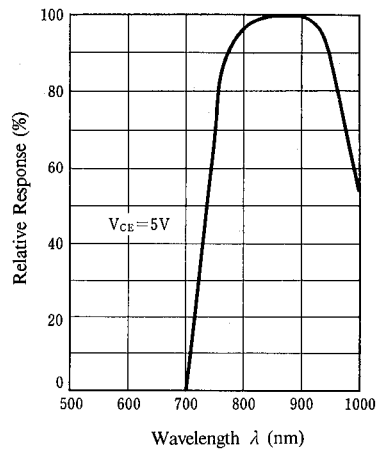

Output Current vs. Distance (Ta=25°C)

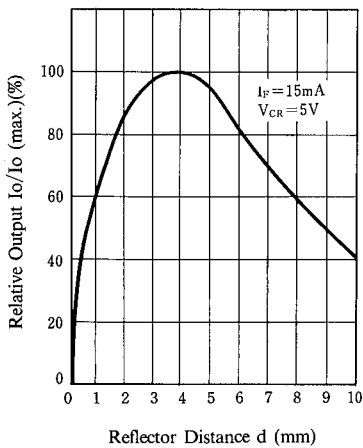

Output Current vs. Edge Distance (Ta=25°C)

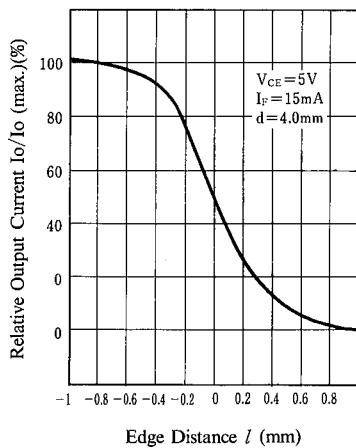

■ MEASURING SPECIFICATION FOR EDGE RESPONSE

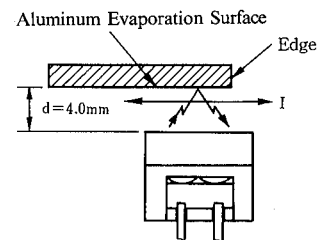

PRECAUTION FOR HANDLING

1. Soldering

1) Avoid the reflow method and the solder to touch the body of the device during wave soldering. This is to prevent changes in optical characteristics of the device.

2) Recommended in Soldering

Temperature	Time Lead	Soldering Position
260°C maximum	less than 5 seconds	At least 1.5mm from body

3) Soldering is recommended to be done in as short period of the time as possible by controlling the temperature of the soldering iron or by the iron of less than 15 watts.

4) The resin gets softened right after soldered, so, the following care has to be taken.

- Not to contact the lens surface to anything
- Not to dip the device into water or any solvents

5) It is recommended not to solder when the leads or between the lead get pulled, depressed or twisted.

6) In the case of using rosin flux, be careful to avoid contact with the lens surface. If the lens is covered with the flux, the specified characteristics cannot be achieved.

2. Post Solder Cleaning

1) Not to dip the plastic part of the device. Dip just the leads when the organic solvent is used for cleaning flux.

2) Not to use any other than solvent specified by the manufacture to avoid impact on the optical characteristics.

3) Since the lens are made of acryl type material, avoid to keep the device in the solvent or keep it in vapor of the solvent even during the mounting or using.

3. Attention in handling

1) Avoid dust and any other foreign materials(flux, paint, bonding material, etc) on the lens surface.

2) Never to apply reverse voltage(V_{EC}) of more than 6V on the photo transistor when measuring the characteristics or adjusting the system. If applied, it causes to lower the sensitivity.

3) When mounting, special care has to be taken on the mounting position and tilting of the device because it is very important to place the device to the optimum position to the object.

4) The use of the device without the holder or the use of the device re-placed the holder eliminates warranty of the product.

5) Avoid the evaluation or use in liquid because the lens is not completely sealed.

4. Storage

The leads are silver plated and they are discolored if the device is left open to the air for long after taken out of the envelope. It causes deterioration of soldering characteristics. Mount the device as short as possible after opening the envelope.

MEMO

[CAUTION]

The specifications on this databook are only given for information, without any guarantee as regards either mistakes or omissions. The application circuits in this databook are described only to show representative usages of the product and not intended for the guarantee or permission of any right including the industrial rights.