

MC68EZ328

MC68EZ328 (DragonBall™ EZ) Integrated Portable System Processor Product Brief

The second member of the DragonBall family, the MC68EZ328 (shown in Figure 1), inherits the display capability of the original DragonBall processor but features a more flexible LCD controller with a streamlined list of peripherals placed in a smaller package. This processor is mainly targeted for portable consumer products which require less peripherals and a more flexible LCD controller. By providing 3.3V, fully static operation in efficient 100 TQFP and 144 MAPBGA packages, the MC68EZ328 delivers cost-effective performance to satisfy the extensive requirements of today's portable consumer market.

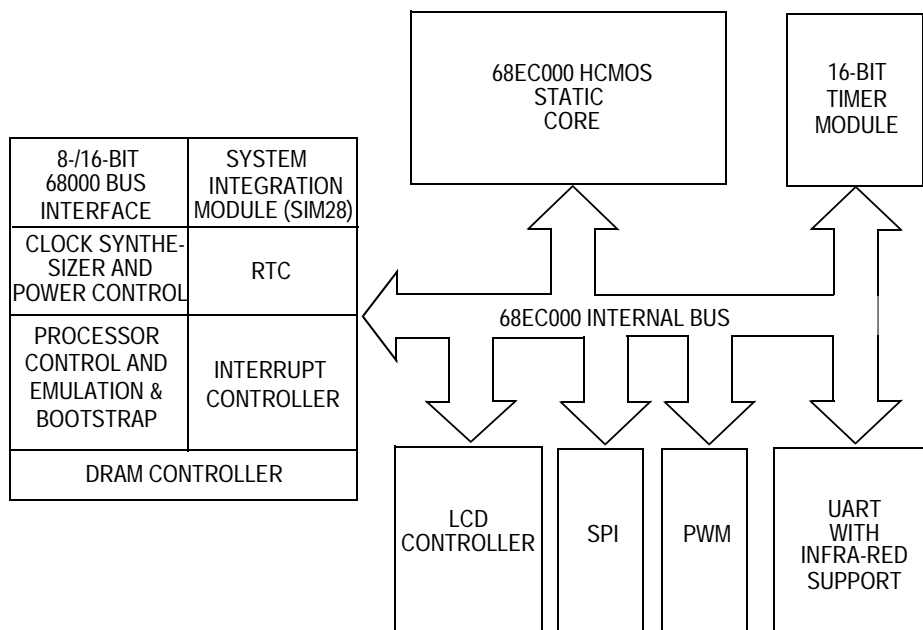

Figure 1. MC68EZ328 Block Diagram

1 Key Features

The primary features of the MC68EZ328 are as follows:

- Static 68EC000 Core Processor—Identical to MC68EC000 Microprocessor
 - Full compatibility with MC68000 and MC68EC000
 - 32-Bit internal address bus
 - 24-Bit external address bus capable of addressing maximum 4 x 16MB blocks with chip selects CSA, CSB and 4 x 4 MB blocks with chip selects CSC, CSD
 - 16-Bit on-chip data bus for MC68000 bus operations
 - Static design allows processor clock to be stopped to provide power savings
 - 2.7 MIPS Performance at 16.58 MHz processor clock and 3.25 MIPS Performance at 20 MHz processor clock
 - External M68000 Bus interface with selectable bus sizing for 8-bit and 16-bit data ports
- System Integration Module (SIM28-EZ), incorporating many functions typically related to external array logic, such as:
 - System configuration, programmable address mapping
 - Glueless interface to SRAM, EPROM, FLASH memory
 - 8 programmable chip selects with wait state generation logic
 - 4 programmable interrupt I/O and with keyboard interrupt capability
 - 5 general purpose, programmable edge/level/polarity interrupt IRQ
 - Other programmable I/O, multiplexed with peripheral functions up to 47 parallel I/O
 - Programmable interrupt vector response for on-chip peripheral modules
 - Low-power mode control
- DRAM Controller
 - Support $\overline{\text{CAS}}$ -before- $\overline{\text{RAS}}$ refresh cycles and self-refresh mode DRAM
 - Support 8 bit / 16 bit port DRAM
 - EDO or Automatic Fast Page Mode for LCDC access
 - Programmable refresh rate
 - Support up to 2 banks of DRAM/EDO DRAM
 - Programmable column address size
- UART
 - Support IrDA physical layer protocol up to 115.2kbps
 - 8 Bytes FIFO on Tx and 12 Bytes FIFO on Rx
- Serial Peripheral Interface Port
 - 16 bit programmable SPI to support external peripherals
 - Master mode support
- 16-Bit General Purpose Counter / Timer
 - Automatic interrupt generation
 - 60-ns resolution at 16.58-MHz system clock

- Timer Input/Output pin
- Real Time Clock / Sampling Timer
 - Separate power supply for the RTC
 - One programmable alarm
 - Capable to count up to 512 days
 - Sampling Timer with selectable frequency (4Hz, 8Hz, 16Hz, 32Hz, 64Hz, 128Hz, 256Hz, 512Hz); generate interrupt for digitizer sampling, or keyboard debouncing
- LCD Controller
 - Software programmable screen size (up to 640*512) to support single (Non-Split) monochrome panels
 - Capable of direct driving popular LCD drivers/modules from Motorola, Sharp, Hitachi, Toshiba etc.
 - Supports b/w, 4-grey and 16-grey level display
 - Utilize system memory as display memory
 - LCD contrast control using 8-bit PWM
- Pulse Width Modulation (PWM) Module
 - 8 bit resolution
 - 5 Byte FIFO provide more flexibility on performance
 - Sound and melody generation
- Built-in Emulation Function
 - Dedicated memory space for Emulator Debug Monitor with Chip Select
 - Dedicated interrupt (Interrupt Level 7) for ICE
 - One address signal comparator and one control signal comparator with masking to support single or multiple Hardware Execution Breakpoint
 - One breakpoint instruction insertion unit
- Bootstrap Mode Function
 - Allows user to initialize system and download program/data to system memory through UART
 - Accept execution command to run program stored in system memory
 - Provide an 8-byte long Instruction Buffer for 68000 instruction storage and execution
- Power Management
 - Fully static HCMOS technology
 - Programmable clock synthesizer using 32.768 kHz/38.4 kHz crystal for full frequency control
 - Low power stop capabilities
 - Modules can be individually shut-down
 - Lowest power mode control
- Operation from DC To 16.58 MHz (processor clock)
- Operating voltage of (3.3 +/- 10%) V
- Compact 100-Lead and 144-Pin MAPBGA TQFP packages

2 System Integration Module

The MC68EZ328 system integration module (SIM28-EZ) consists of several functions that control the system start-up, initialization, configuration, and the external bus with a minimum of external devices. The memory interface allows the user to interface gluelessly with the widely available SRAM and EPROM as well as FLASH memory. With the assistance of chip-select logic, wait states can be programmable. The interrupt controller accepts and resolves the priority from internal modules and external generated interrupts. It also handles the masking and wake-up selection control for power control. The low-power logic can be used to control the CPU power dissipation by altering the frequency or stopping the CPU. In addition, the SIM28-EZ is capable of configuring the pin to allow the user to select either dedicated I/O or parallel I/O. This feature help to increase the number of available I/O ports by reclaiming when the dedicated function is not used.

2.1 System Configuration

The MC68EZ328 system configuration logic consists of a system control register (SCR) which allows the user to configure operation of the following major functions:

- System Status and Control Logic
- Bus Error Generation Control
- Protect module control registers from access by user programs

2.2 VCO/PLL Clock Synthesizer

The clock synthesizer can operate with either an external crystal or an external oscillator for reference, using the internal phase-locked loop (PLL) and voltage-controlled oscillator (VCO), or an external clock can directly drive the clock signal at the operating frequency.

2.3 Chip Select Logic

The MC68EZ328 provides eight programmable general purpose chip-select signals. For a given chip-select block, the user may choose whether the chip-select allows read-only, or both read and write accesses, whether a \overline{DTACK} is automatically generated for this chip-select, and after how many wait states (from zero to six) the \overline{DTACK} will be generated.

2.4 External Bus Interface

The external bus interface handles the transfer of information between the internal 68EC000 core and the memory, peripherals, or other processing elements in the external address space. It consists of a 16 bit 68000 bus interface for internal and a 8 bit interface to outside.

2.5 Interrupt Controller

The interrupt controller accepts and prioritizes both internal and external interrupt requests and generates a vector number during the CPU interrupt acknowledge cycle. Interrupt nesting is also provided so that an

interrupt service routine of a lower priority interrupt may be suspended by a higher priority interrupt request. The on-chip interrupt controller has the following major features:

- Prioritized Interrupt Sources (Internal and External)
- A Fully Nested Interrupt Environment
- Programmable Vector Generation
- Interrupt Masking
- Wake-up interrupt Masking

2.6 Parallel General-Purpose I/O Ports

The MC68EZ328 supports up to 54-bit general-purpose I/O ports, which can be configured as general-purpose I/O pins or as dedicated peripheral interface pins of the on-chip modules. Each port pin can be independently programmed as general-purpose I/O pin, while other pins related to the same on-chip peripheral can be used as dedicated pins. Even all the pins for a particular peripheral are configured as general-purpose I/O, the peripheral will still operate normally, although this is only useful in the case of the RTC and timer modules.

2.7 Low-Power Stop Logic

Various options for power-saving are available: turning off unused peripherals, reducing processor clock speed, disabling the processor altogether, or a combination of these.

A wake-up from low-power mode can be achieved by causing an interrupt at the interrupt controller logic which runs throughout the period of processor low-power. Selectable interrupt will cause a wake-up of the 68EC000 core. The on-chip peripherals can initiate a wake-up; for example, the timer can be set to wake up after a certain elapsed time, or number of external events.

3 DRAM Controller

In order to provide more flexibility for system designers, the MC68EZ328 support a glueless interface to 8-bit or 16 bit DRAM. This DRAM controller supports up to two banks of DRAM/EDO DRAM with each bank up to 512kx8, 256kx16, 1Mx16, or 8Mx8. In addition, CAS-before-RAS refresh cycles and Self-Refresh mode DRAM are also supported.

4 UART and Infra-red Communication Support

The UART supports standard asynchronous serial communications at normal baud rates and is compatible with IrDA 1.0 Physical Communication Protocol with up to 115.2 Kbps.

5 Serial Peripheral Interface (SPI)

The serial peripheral interface is a master mode, high-speed synchronous serial port for communicating to external devices such as A/D converters and non-volatile RAMs. The interface is a 3 or 4 wire system depending on unidirectional or bidirectional communication mode. This SPIM provides the clock for data transfer and will function as a master-mode device.

6 Timer

The MC68EZ328 processor contains a general-purpose 16 bit timer with a programmable prescaler. This timer also has input capture capability with programmable trigger edge and output compare. The resolution is 240 ns when the system clock is 16.58 MHz.

7 Real Time Clock

The Real Time Clock in MC68EZ328 is driven by a 32.768kHz/38.4kHz Crystal which is the same as the Clock Synthesizer clock source. It also provides interrupt for alarm. RTC also provides sampling capability. Users can select from a predefined frequency and an interrupt will be generated accordingly. This sampling timer can be used for digitizer sampling, or keyboard debouncing.

8 LCD Controller

The LCD controller for the MC68EZ328 is similar to the original DragonBall LCD controller but has more flexibility on grey level palette support and smaller screen size. Specific features are as follows:

- Interfaces with Monochrome STN modules
- Up to 4 Levels of Gray Scale out of 16 Palettes through Frame Rate Control
- Utilize system RAM for display memory
- Screen Refresh through DMA
- Configurable Screen Size up to 640*512
- LCD Contrast Control using 8-bit PWM

9 Pulse Width Modulation (PWM)

The pulse-width modulator (PWM) of the MC68EZ328 is optimized to generate high-quality sound from stored sample audio images. This PWM has 8 bit resolution and contains a 5 byte FIFO which can minimize interrupt overhead. A maskable interrupt is generated whenever there are 1 or 0 byte in the FIFO, the software can then write either 4 byte samples or 2 two words sample into the FIFO, which can enhance performance for audio applications.

10 Built-in Emulation Function

The In-Circuit Emulation Module (ICEM) provides on-chip emulation functions for the MC68EZ328. It is designed for low-cost emulator with only four signals to interface. More detailed information will be provided from external emulator vendors.

Motorola reserves the right to make changes without further notice to any products herein. Motorola makes no warranty, representation or guarantee regarding the suitability of its products for any particular purpose, nor does Motorola assume any liability arising out of the application or use of any product or circuit, and specifically disclaims any and all liability, including without limitation consequential or incidental damages. "Typical" parameters which may be provided in Motorola data sheets and/or specifications can and do vary in different applications and actual performance may vary over time. All operating parameters, including "Typicals" must be validated for each customer application by customer's technical experts. Motorola does not convey any license under its patent rights nor the rights of others. Motorola products are not designed, intended, or authorized for use as components in systems intended for surgical implant into the body, or other applications intended to support life, or for any other application in which the failure of the Motorola product could create a situation where personal injury or death may occur. Should Buyer purchase or use Motorola products for any such unintended or unauthorized application, Buyer shall indemnify and hold Motorola and its officers, employees, subsidiaries, affiliates, and distributors harmless against all claims, costs, damages, and expenses, and reasonable attorney fees arising out of, directly or indirectly, any claim of personal injury or death associated with such unintended or unauthorized use, even if such claim alleges that Motorola was negligent regarding the design or manufacture of the part. Motorola, Inc. is an Equal Opportunity/Affirmative Action Employer. MOTOROLA and the Stylized M Logo are registered in the US Patent & Trademark Office. All other product or service names are the property of their respective owners.
© Motorola, Inc. 2001.

How to reach us:

USA/EUROPE/Locations Not Listed: Motorola Literature Distribution; P.O. Box 5405, Denver, Colorado, 80217.
1-303-675-2140 or 1-800-441-2447

JAPAN: Motorola Japan Ltd.; SPS, Technical Information Center, 3-20-1, Minami-Azabu, Minato-ku,
Tokyo 106-8573 Japan. 81-3-3440-3569

ASIA/PACIFIC: Motorola Semiconductors H.K. Ltd., Silicon Harbour Centre, 2 Dai King Street,
Tai Po Industrial Estate, Tai Po, N.T., Hong Kong. 852-26668334

Technical Information Center: 1-800-521-6274

HOME PAGE: <http://www.motorola.com/semiconductors/>



MOTOROLA

MC68EZ328P/D