

HIGH-PERFORMANCE PRODUCTS

Description

The SK10/100EL14W is a 1:5 Clock Distribution Chip designed specifically for low skew clock distribution applications. This device is fully compatible with MC100EL14 and MC100LVEL14.

The device can be driven by either differential or single-ended ECL/PECL input signals. The SK10/100EL14W provides a V_{BB} output for either single-ended use or DC bias for AC coupling to the device. V_{BB} is an output pin and should be used as a bias for the EL14W as its current sink/source capability is limited. Whenever used, V_{BB} should be bypassed to VCC via a 0.01 μ F capacitor.

The EL14W features a multiplexed clock input to allow for the distribution of a lower speed scan or test clock along with the high speed system clock. When LOW (or left open and pulled LOW by the input pulldown resistor) the SEL pin will select the differential clock input. The Common Enable pin (EN*) is synchronous so that the outputs will only be enabled/disabled when they are already in the LOW state. This avoids the chance of generating a runt clock pulse when the device is enabled/disabled as can happen with an asynchronous control. The internal flip-flops are clocked on the falling edge of the input clock; therefore, all associated specification limits are referenced to the negative edge of the clock input.

Functional Block Diagram

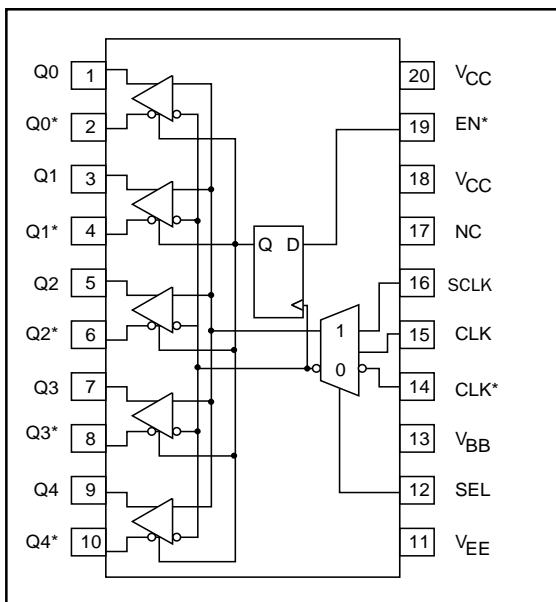

Features

- Extended Supply Voltage Range: ($V_{EE} = -5.5V$ to $-3.0V$, $V_{CC} = 0V$) or ($V_{CC} = +3.0V$ to $+5.5V$, $V_{EE}=0V$)
- High Bandwidth Output Transition
- Max. 50 ps Output-to-Output Skew (Typ. 30 ps)
- V_{BB} Output
- Synchronous Enable/Disable
- Multiplexed Clock Input
- 75 K Ω Internal Input Pulldown Resistors
- New Differential Input Common Mode Range
- Fully Compatible with MC100EL14 and MC100LVEL14
- ESD Protection of >4000 V
- Industrial Temperature Range: $-40^{\circ}C$ to $+85^{\circ}C$
- Available in 20-Pin SOIC (150 mils) Package

Pin Descriptions

Pin	Function
CLK, CLK*	Differential Clock Inputs
SCLK	Scan Clock Input
EN*	Sync Enable
SEL	Clock Select Input
V_{BB}	Reference Output Voltage
Q0-Q4, Q0*-Q4*	Differential Clock Outputs

Function Table

CLK	SCLK	SEL	EN*	Q
L	X	L	L	L
H	X	L	L	H
X	L	H	L	L
X	H	H	L	H
X	X	X	H	L*

* On next negative transition of CLK or SCLK

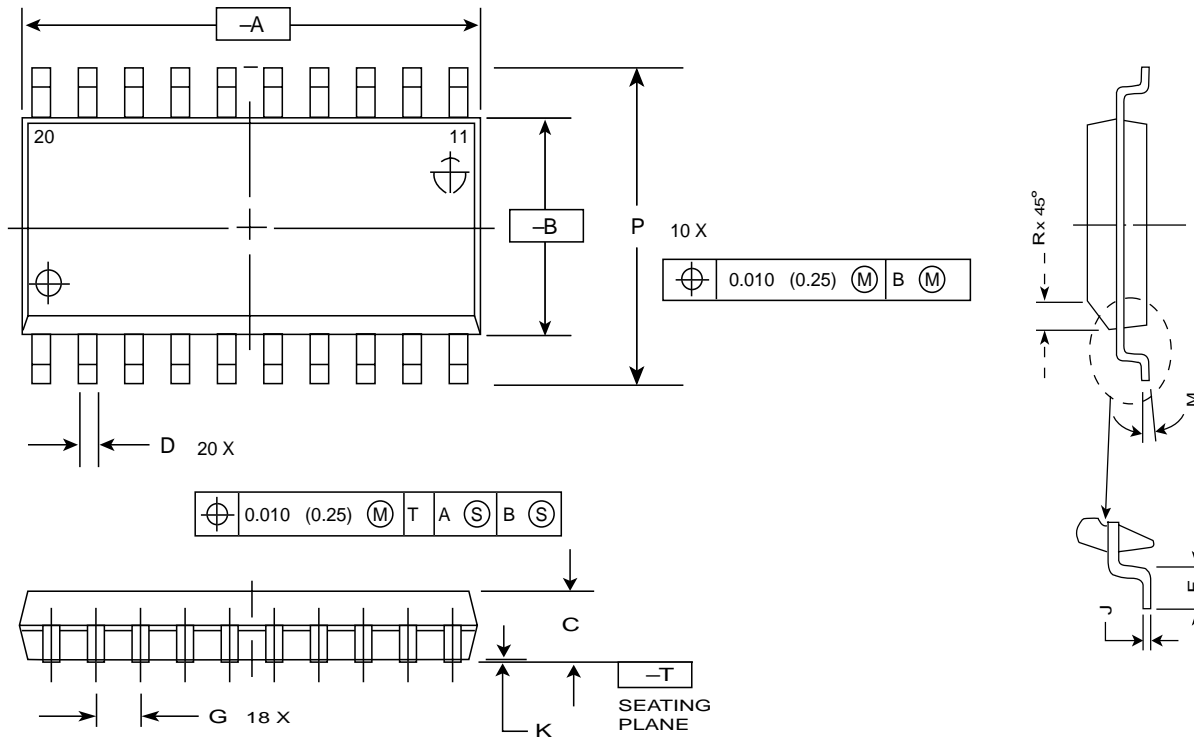
20 Pin SOIC Package

Millimeters

DIM	MILLIMETERS	
	MIN	MAX
A	1.35	1.75
A1	0.10	0.25
B	0.33	0.51
C	0.19	0.25
D	4.80	5.00
E	3.80	4.00
e	1.27 BSC	
H	5.80	6.20
h	0.25	0.50
L	0.40	1.27
θ	0°	8°

NOTES:

1. Dimensions and tolerances per ANSI Y14.5M, 1982.
2. Controlling dimension: millimeter.
3. Dimensions A and B do not include mold protrusion.
4. Maximum mold protrusion 0.150 (0.006) per side.
5. Dimension D does not include Dambar protrusion. Allowable Dambar protrusion shall be 0.13 (0.005) total in excess of d dimension at maximum material condition.

HIGH-PERFORMANCE PRODUCTS
DC Characteristics
SK10/100EL14W DC Electrical Characteristics (Notes 1, 2)
 $(V_{CC} - V_{EE} = +3.0V \text{ to } +5.5V ; V_{OUT} \text{ loaded } 50\Omega \text{ to } V_{CC} - 2.0V)$

Symbol	Characteristic	TA = -40°C			TA = 0°C			TA = +25°C			TA = +85°C			Unit
		Min	Typ	Max	Min	Typ	Max	Min	Typ	Max	Min	Typ	Max	
I _{EE}	Power Supply current 10EL 100EL	22	28	38	23	30	39	24	30	40	25	32	42	mA mA
		22	28	38	23	30	40	24	31	41	27	34	46	
V _{BB}	Output Reference Voltage ³ 10EL 100EL	-1.43		-1.30	-1.38		-1.27	-1.35		-1.25	-1.31		-1.19	V V
		-1.38		-1.26	-1.38		-1.26	-1.38		-1.26	-1.38		-1.26	
I _{IN}	Input Current (Diff) (SE)	-150		150	-150		150	-150		150	-150		150	μA μA
				150			150			150			150	

AC Characteristics
SK10/100EL14W AC Electrical Characteristics
 $(V_{CC} - V_{EE} = +3.0V \text{ to } +5.5V ; V_{OUT} \text{ loaded } 50\Omega \text{ to } V_{CC} - 2.0V)$

Symbol	Characteristic	TA = -40°C		TA = 0°C		TA = +25°C		TA = +85°C		Unit
		Min	Max	Min	Max	Min	Max	Min	Max	
t _{PLH}	Propagation Delay CLK to Q (Diff)	630	755	650	785	660	805	695	860	Ps
t _{PHL}	CLK to Q (SE)	555	710	570	740	580	760	605	815	Ps
	SCLK to Q	520	765	550	780	570	790	620	830	Ps
t _{skew}	Part-to-Part Skew Within Device Skew ⁴		200		200		200		200	ps ps
			50		50		50		50	
t _S	Setup Time EN*	0		0		0		0		ps
t _H	Hold Time EN*	0		0		0		0		ps
V _{PP}	Minimum Input Swing CLK ⁵	150	1000	150	1000	150	1000	150	1000	mV
V _{CMR}	Common Mode Range ⁶ V _{PP} < 500 mV V _{PP} > 500 mV	VEE+1.3	VCC-0.4	VEE+1.3	VCC-0.4	VEE+1.3	VCC-0.4	VEE+1.3	VCC-0.4	V V
		VEE+1.5	VCC-0.4	VEE+1.5	VCC-0.4	VEE+1.5	VCC-0.4	VEE+1.5	VCC-0.4	
t _r , t _f	Output Rise/Fall Times (20% to 80%) Q0-Q4, Q0*-Q4*	205	355	215	370	220	380	240	410	ps

HIGH-PERFORMANCE PRODUCTS
AC Characteristics (continued)
Notes:

1. 10EL circuits are designed to meet the DC specifications shown in the table after thermal equilibrium has been established. The circuit is in a test socket or mounted on a printed circuit board and transverse airflow greater than 500 lfpm is maintained. Outputs are terminated through a 50Ω resistor to VCC -2.0V.
2. 100K circuits are designed to meet the DC specification shown in the table where transverse airflow greater than 500 lfpm is maintained.
3. Voltages are referenced to VCC = 0V.
4. Skews are specified for identical LOW-to-HIGH or HIGH-to-LOW transitions.
5. Minimum input swing for which AC parameters guaranteed.
6. CMR range is referenced to the most positive side of the differential input signal. Normal operation is obtained if the high level falls within the specified range and the peak-to-peak voltage lies between $V_{PP(\min)}$ and 1V. The lower end of the CMR range varies 1:1 with VEE and is equal to VEE + 1.3V for $V_{PP} < 500$ mV, and VEE + 1.5 for $V_{PP} > 500$ mV.
7. For standard ECL DC specifications, refer to the ECL Logic Family Standard DC Specifications Data Sheet.
8. For part ordering descriptions, see HPP Part Ordering Information Data Sheet.

Ordering Information

Ordering Code	Package ID	Temperature Range
SK10EL14WD	20-SOIC	Industrial
SK10EL14WDT	20-SOIC	Industrial
SK100EL14WD	20-SOIC	Industrial
SK100EL14WDT	20-SOIC	Industrial
SK10EL14WU	Die	
SK100EL14WU	Die	

Contact Information

Division Headquarters
 10021 Willow Creek Road
 San Diego, CA 92131
 Phone: (858) 695-1808
 FAX: (858) 695-2633

Semtech Corporation
High-Performance Products Division

Marketing Group
 1111 Comstock Street
 Santa Clara, CA 95054
 Phone: (408) 566-8776
 FAX: (408) 727-8994