

March 11, 1998

TEL:805-498-2111 FAX:805-498-3804 WEB:http://www.semtech.com

DESCRIPTION

The SC1151 voltage mode controller contains most of the circuitry necessary to implement a DC/DC converter for powering advanced microprocessors such as Klamath, both in single and multiple processor configurations.

The SC1151 features an integrated 5 bit D/A converter, pulse by pulse current limiting, integrated power good signaling, logic compatible shutdown and on-board over voltage protection (OVP).

The SC1151 operates at a fixed frequency of 200kHz, providing an optimum compromise between size, efficiency and cost in the intended application areas.

The integrated D/A converter provides programmability of output voltage from 2.0V to 3.5V in 100mV increments and 1.80V to 2.05V in 50mV increments with no external components.

The SC1151 provides an OVP output which can be used to trigger a crowbar circuit for true over voltage protection.

FEATURES

- 85% efficiency
- 5 bit DAC for output programmability
- On chip power good and OVP functions
- Designed for Intel Klamath VRM8.1 requirements

APPLICATIONS

- Klamath microprocessor supplies
- Klamath VRM modules
- 1.8V to 3.5V microprocessor supplies
- Programmable power supplies

ORDERING INFORMATION

DEVICE ⁽¹⁾	PACKAGE	TEMP RANGE (T _J)
SC1151CS	SO-16	0° to 125°C

Note:

(1) Add suffix 'TR' for tape and reel.

BLOCK DIAGRAM

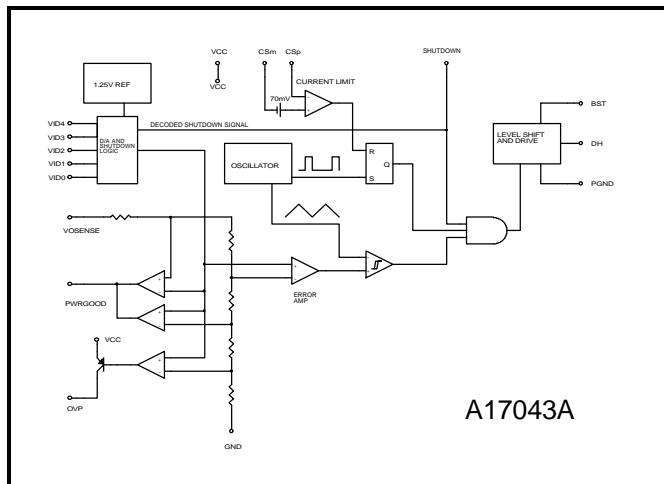

PIN CONFIGURATION

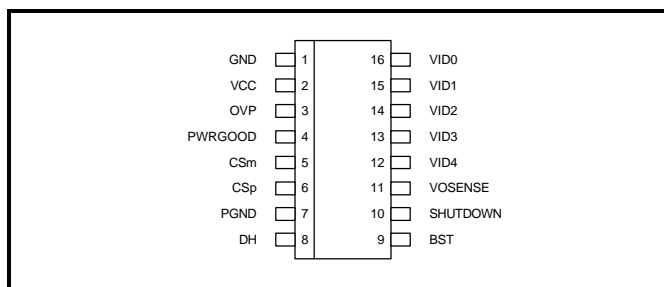

ABSOLUTE MAXIMUM RATINGS

Parameter	Symbol	Maximum	Units
V _{CC} to GND	V _{IN}	-0.3 to 7	V
PGND to GND		± 1	V
BST to GND		-0.3 to 15	V
Operating Temperature Range	T _A	0 to 70	°C
Storage Temperature Range	T _{STG}	-65 to +150	°C
Lead Temperature (Soldering) 10 sec	T _{LEAD}	300	°C

March 11, 1998

ELECTRICAL CHARACTERISTICS

 Unless specified: $V_{CC} = 4.75V$ to $5.25V$; $GND = PGND = 0V$; $V_{OSENSE} = V_O$; $0mV < (CSp-CSm) < 60mV$; $T_A = 25^\circ C$

PARAMETER	CONDITIONS	VID	MIN	TYP	MAX	UNITS
		43210				
Output Voltage ⁽²⁾	$I_O = 2A$ in Application circuit 16935F	00101	1.782	1.800	1.818	V
		00100	1.832	1.850	1.868	
		00011	1.881	1.900	1.919	
		00010	1.931	1.950	1.969	
		00001	1.980	2.000	2.020	
		00000	2.030	2.050	2.070	
		11111	1.980	2.000	2.020	
		11110	2.079	2.100	2.121	
		11101	2.178	2.200	2.222	
		11100	2.277	2.300	2.323	
		11011	2.376	2.400	2.424	
		11010	2.475	2.500	2.525	
		11001	2.574	2.600	2.626	
		11000	2.673	2.700	2.727	
		10111	2.772	2.800	2.828	
		10110	2.871	2.900	2.929	
		10101	2.970	3.000	3.030	
		10100	3.069	3.100	3.131	
		10011	3.168	3.200	3.232	
		10010	3.267	3.300	3.333	
10001	3.366	3.400	3.434			
10000	3.465	3.500	3.535			
Load Regulation	$I_O = 0.3A$ to $13A^{(1)}$	xxxxx		1		%
Line Regulation		xxxxx		0.5		%
UV Lockout		xxxxx			4.2	V
Current Limit Voltage		xxxxx	60	70	80	mV
Oscillator Frequency		xxxxx	180	200	220	kHz
Oscillator Max Duty Cycle		xxxxx	90	95		%
DH Sink/Source Current	BST - DH = 4.5V, DH - PGND = 2V	xxxxx	1			A
Output Voltage Tempco		xxxxx		65		ppm/ $^\circ C$

NOTES:

(1) Low output currents, below the continuous conduction threshold will cause an increase in output voltage beyond the load regulation limit. For Application circuit 16935F see the regulation curve on sheet 5.

(2) All VID codes not specifically listed here are invalid and cause shutdown exactly as if the shutdown pin had been asserted. xxxxx refers to any valid VID code.

March 11, 1998

PIN DESCRIPTION

Pin #	Pin Name	Pin Function
1	GND	Small Signal Analog and Digital Ground
2	V _{CC}	Chip Supply Voltage
3	OVP	High Signal out if V _O >setpoint + 20%
4	PWRGOOD ⁽¹⁾	Open collector logic output, high if V _O within 10% of setpoint
5	CS _m	Current Sense Input (negative)
6	CS _p	Current Sense Input (positive)
7	PGND	Power Ground
8	DH	High Side Driver Output
9	BST	V _{CC} for High Side Driver
10	SHUTDOWN ⁽¹⁾	Logic low shuts down the converter
11	V _{OSENSE}	Top end of internal feedback chain
12	VID4 ⁽¹⁾	Programming Input (MSB)
13	VID3 ⁽¹⁾	Programming Input
14	VID2 ⁽¹⁾	Programming Input
15	VID1 ⁽¹⁾	Programming Input
16	VID0 ⁽¹⁾	Programming Input (LSB)

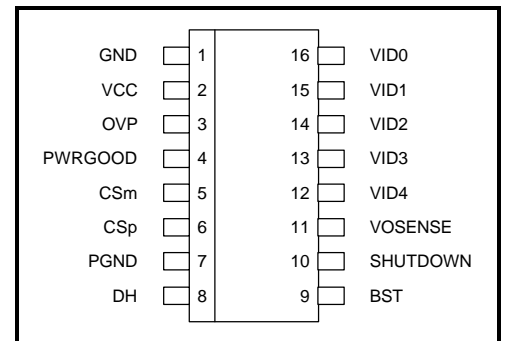
NOTE:

(1) All logic level inputs and outputs are open collector TTL compatible

March 11, 1998

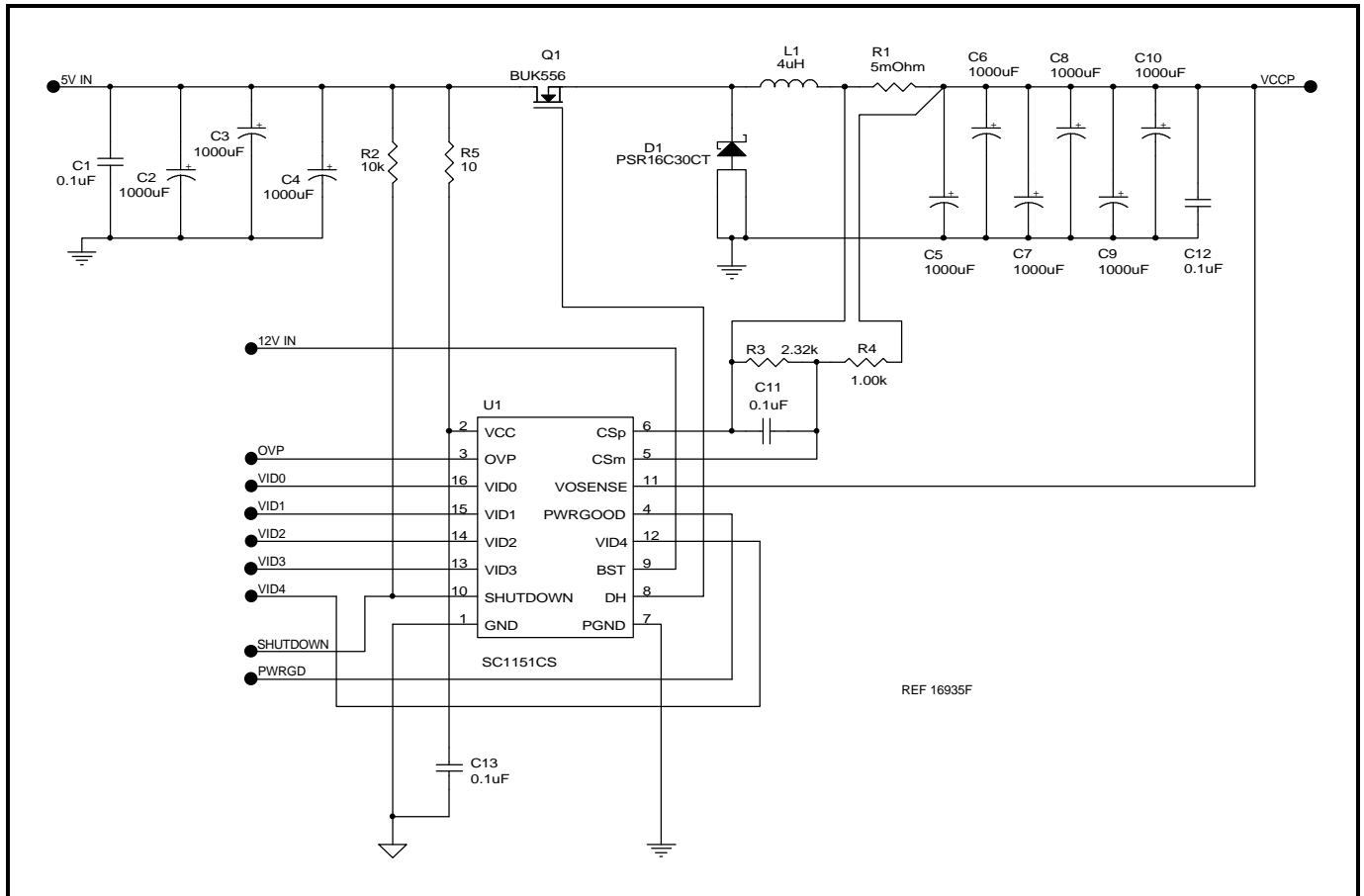
APPLICATION CIRCUIT

MATERIALS LIST

Quantity	Reference	Part/Description	Vendor	Notes
4	C1,C11-C13	0.1 μ F Ceramic	Various	
9	C2-C10	1000 μ F/6.3V	SANYO	MV-GX or equiv. Low ESR
1	D1	PSR16C30CT	PHOTRON	
1	L1	4 μ H		8 Turns 16AWG on MICROMETALS T50-52D core
1	Q1	BUK556	PHILIPS	Logic level FET, \leq 22m Ω , 30V
1	R1	5m Ω	IRC	OAR-1 Series
1	R2	10k Ω , 5%, 1/8W	Various	
1	R3	2.32k Ω , 1%, 1/8W	Various	
1	R4	1k Ω , 1%, 1/8W	Various	
1	R5	10 Ω , 5%, 1/8W	Various	
1	U1	SC1151CS	SEMTECH	

March 11, 1998

CHARACTERISTIC CURVES

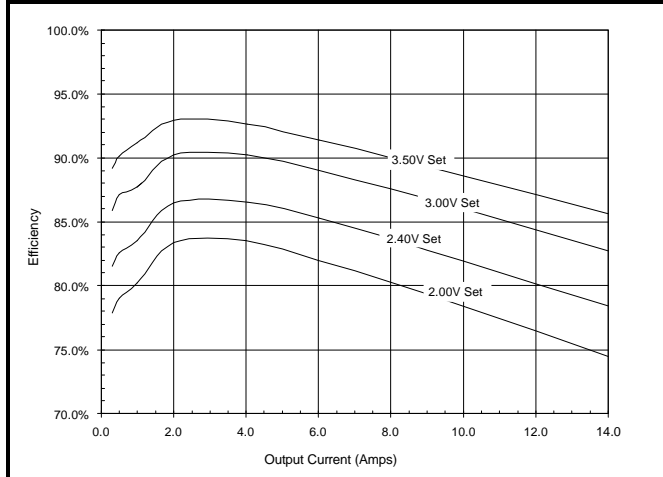
SC1151 Efficiency in Application circuit 16935F



Application circuit 16935F Ripple, 3.1V, 10A out

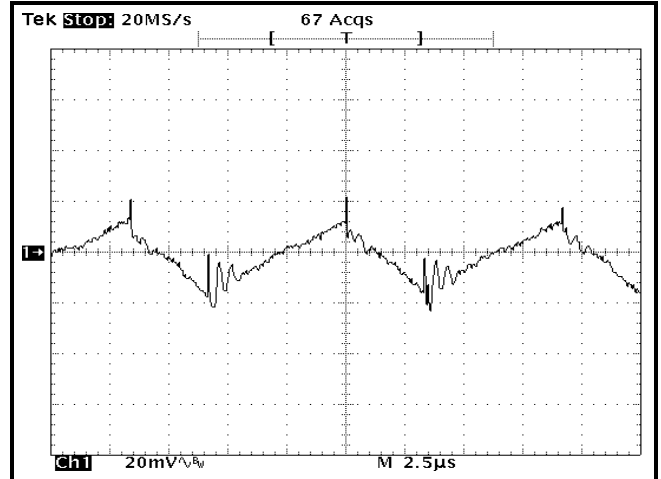

Application circuit 16935F Transient Response, 3.1V, 0.3A to 10A

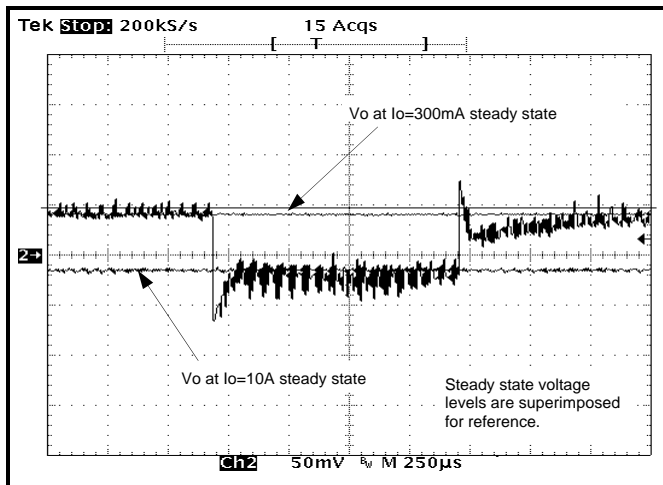

SC1151 Regulation in Application circuit 16935F

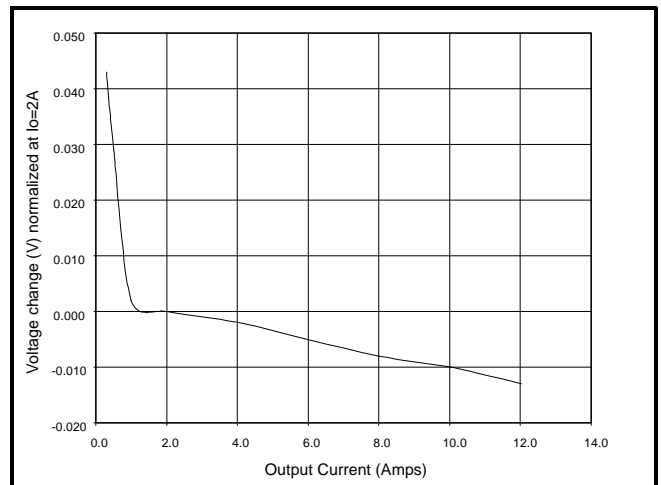

March 11, 1998

OUTLINE DRAWING SO-16

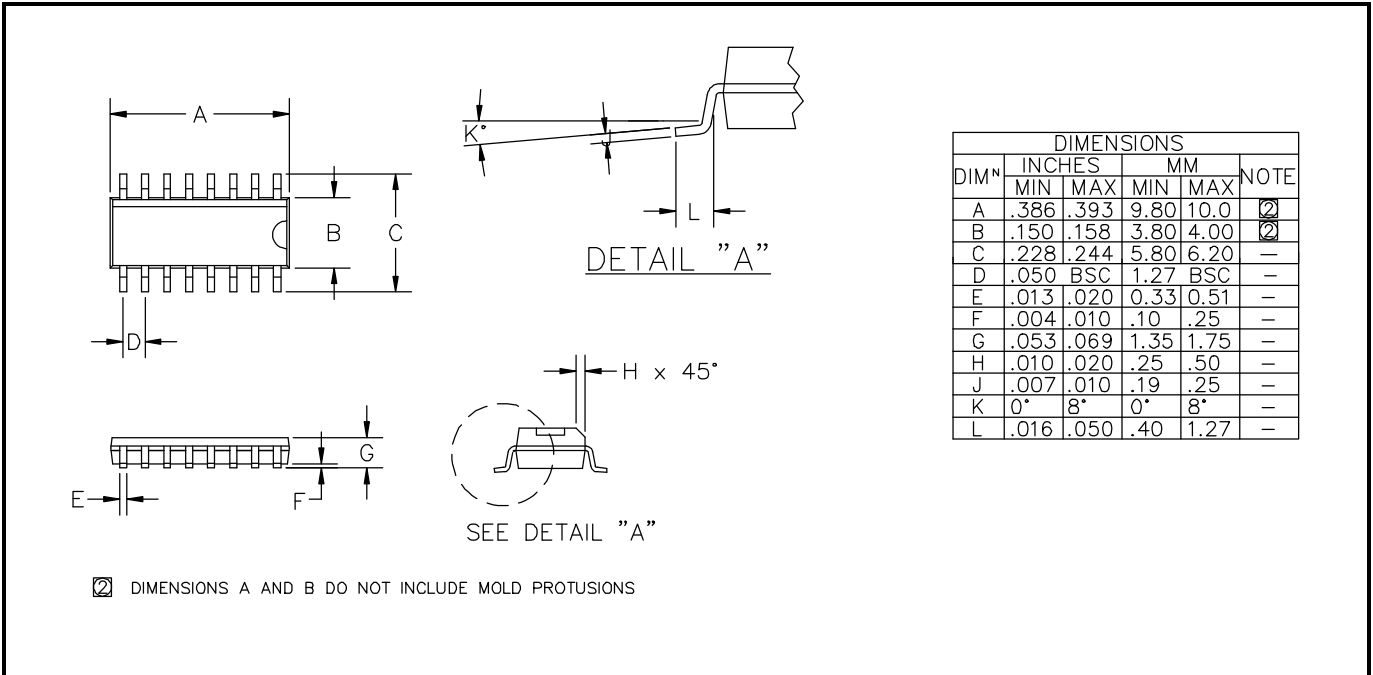

LAND PATTERN SO-16

