



DATA SHEET

SB3020CT~SB3060CT

SCHOTTKY BARRIER RECTIFIERS

VOLTAGE- 20 to 60 Volts CURRENT - 30.0 Ampere



Reconfgnized File #E228882

Unit: inch (mm)

TO-3P

FEATURES

- Plastic package has Underwriters Laboratory Flammability Classification 94V-O. Flame Retardant Epoxy Molding Compound.
- Exceeds environmental standards of MIL-S-19500/228
- Low power loss, high efficiency.
- Low forwrd vltge, high current capability
- High surge capacity.
- For use in low voltage,high frequency inverters free wheeling , and polarity protection applications.

MECHANICAL DATA

Case: TO-3P Molded plastic

Terminals: Solder plated, solderable per MIL-STD-202, Method 208

Polarity: As marked.

Standard packaging: Any

Weight: 0.2 ounces, 5.6grams.

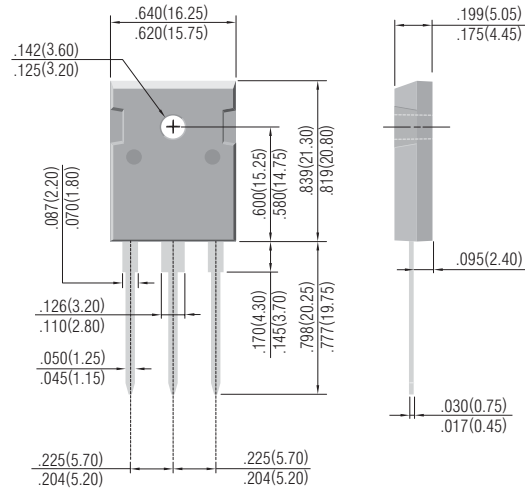

MAXIMUM RATINGS AND ELECTRICAL CHARACTERISTICS

Ratings at 25°C ambient temperature unless otherwise specified.

Single phase, half wave, 60 Hz, resistive or inductive load.

For capacitive load, derate current by 20%

	SYMBOLS	SB3020CT	SB3030CT	SB3040CT	SB3050CT	SB3060CT	UNIT
Maximum Recurrent Peak Reverse Voltage	V_{RRM}	20.0	30.0	40.0	50.0	60.0	V
Maximum RMS Voltage	V_{RMS}	14.0	21.0	28.0	35.0	42.0	V
Maximum DC Blocking Voltage	V_{DC}	20.0	30.0	40.0	50.0	60.0	V
Maximum Average Forward Rectified Current at $T_c=90^\circ\text{C}$	$I(AV)$	30					A
Peak Forward Surge Current, 8.3 ms single half sine-wave superimposed on rated load (JEDEC method)	I_{FSM}	275					A
Maximum Instantaneous Forward Voltage at 15.0A per element	V_F	0.55		0.75			V
Maximum DC Reverse Current (Note 1) $T_a=25^\circ\text{C}$ at Rated DC Blocking Voltage $T_a=100^\circ\text{C}$	I_R	0.5 75.0					mA
Typical Thermal Resistance Note	$R_{\theta JC}$	1.5					$^\circ\text{C/W}$
Operating and Storage Temperature Range T_J	T_J	-50 to +125					$^\circ\text{C}$

NOTES:

1. Thermal Resistance Junction to Ambient .



RATING AND CHARACTERISTIC CURVES

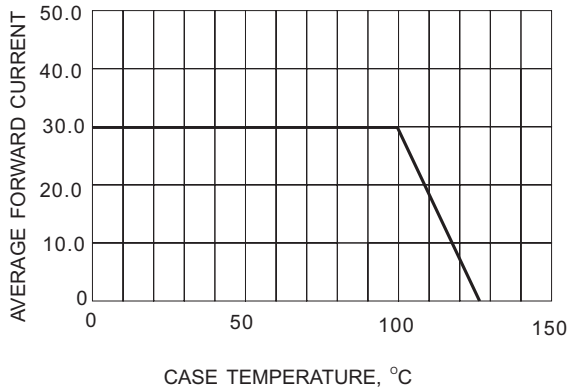

Fig.1- FORWARD CURRENT DERATING CURVE

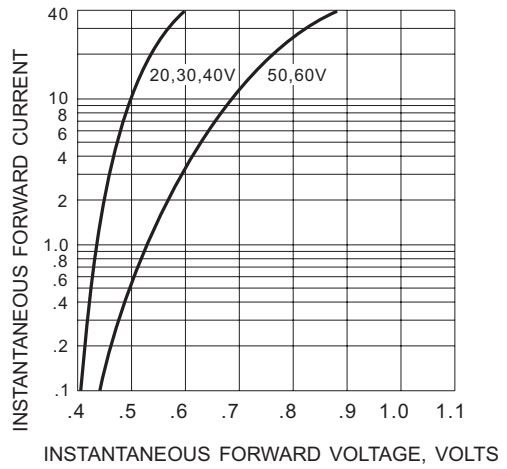

Fig.2- TYPICAL INSTANTANEOUS FORWARD CHARACTERISTIC

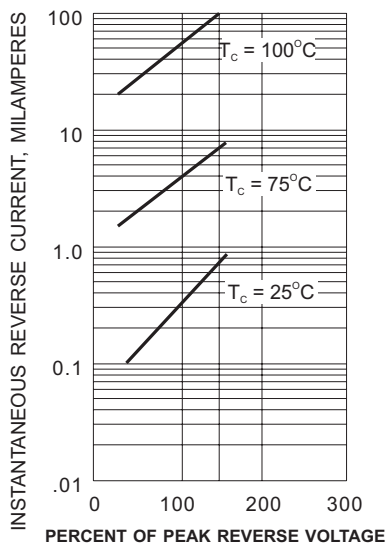

Fig.3- TYPICAL REVERSE CHARACTERISTIC

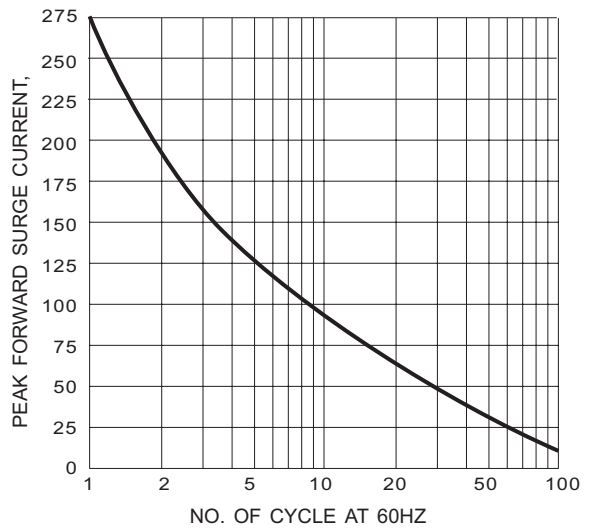

Fig.4- MAXIMUM NON-REPETITIVE SURGE CURRENT

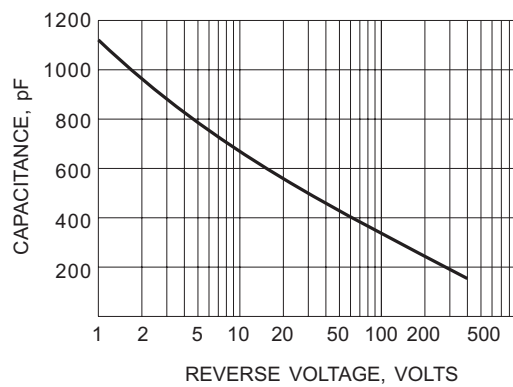

Fig.5- TYPICAL JUNCTION CAPACITANCE