

ASSP For Power Supply Applications

Pentium® DC/DC Converter IC

MB3828

■ DESCRIPTION

The FUJITSU MB3828 is a pulse width modulation (PWM) DC/DC converter IC chip that provides a selection of 1.3 V to 3.5 V output voltages for Pentium® CPU's, using a 5-bit input signal information.

The MB3828 utilizes synchronous rectification for high efficiency and features a soft-start/discharge control function for ease in designing power supplies in multi-supply systems, making it ideal for Pentium® power supply systems.

* : Pentium is the registered trademark of Intel Corporation.

■ FEATURES

- Highly efficient for using synchronous rectification scheme
- On-chip soft-start/discharge control circuit
- High precision output voltage: $\pm 1.2\%$
- 5-bit, 32-step DAC: 3.5 V to 2.1 V in 100 mV steps
2.05 V to 1.3 V in 50 mV steps
- Frequency range: 100 kHz to 500 kHz using variable resistance (on-chip frequency setting capacitance)
- Standby current: 0 μA TYP
- On-chip PWRGOOD circuit for output voltage state detection
- Timer-latch short-circuit protection circuit, and overvoltage protection circuit for output protection

■ PACKAGE

24-pin Plastic SSOP

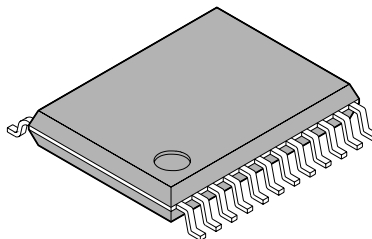

(FPT-24P-M03)

MB3828

■ PIN ASSIGNMENT

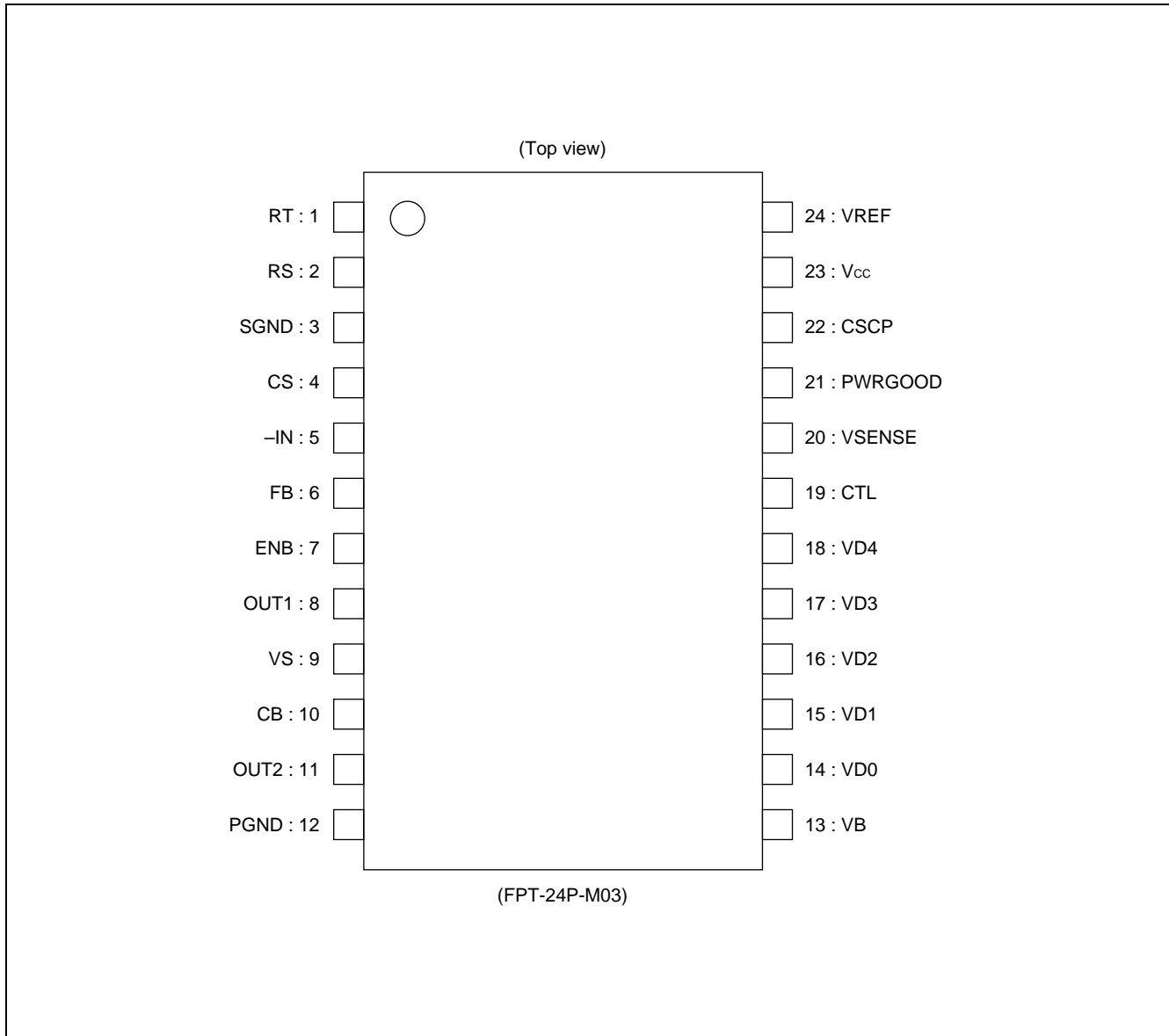

■ PIN DESCRIPTION

Pin no.	Symbol	I/O	Descriptions
1	RT	—	Triangular wave frequency setting resistor connection pin
2	RS	—	Discharging resistor connection pin for soft start capacitor
3	SGND	—	Ground pin
4	CS	—	Soft start capacitor connection pin (Also used for discharge control)
5	-IN	I	Error amplifier inverted input pin
6	FB	O	Error amplifier output pin
7	ENB	I	Discharge control function enable/disable switch control pin
8	OUT1	O	Totem-pole output pin (External main-side FET gate drive)
9	VS	—	External main-side FET source-side connection
10	CB	—	Output bootstrap pin Insert a capacitor between the CB and VS pins, to bootstrap the IC internal output transistor.
11	OUT2	O	Totem-pole output pin (External synchronous rectifier-side FET gate drive)
12	PGND	—	Ground pin
13	VB	—	Output circuit power supply pin
14	VD0	I	5-bit digital input pin used to set DC/DC converter output voltage
15	VD1	I	5-bit digital input pin used to set DC/DC converter output voltage
16	VD2	I	5-bit digital input pin used to set DC/DC converter output voltage
17	VD3	I	5-bit digital input pin used to set DC/DC converter output voltage
18	VD4	I	5-bit digital input pin used to set DC/DC converter output voltage
19	CTL	I	Power supply control pin The CTL pin is set to "L" level to place the IC in standby mode.
20	VSENSE	I	PWRGOOD circuit input pin
21	PWRGOOD	O	PWRGOOD output pin (open-drain output) Outputs a "H" level signal when the output voltage is within the range from VTLOW to VTHIGH.
22	CSCP	—	Timer-latch short-circuit protection capacitor connection pin
23	V _{cc}	—	Power supply pin for reference power and control circuit
24	VREF	O	Reference voltage output pin

MB3828

■ BLOCK DIAGRAM

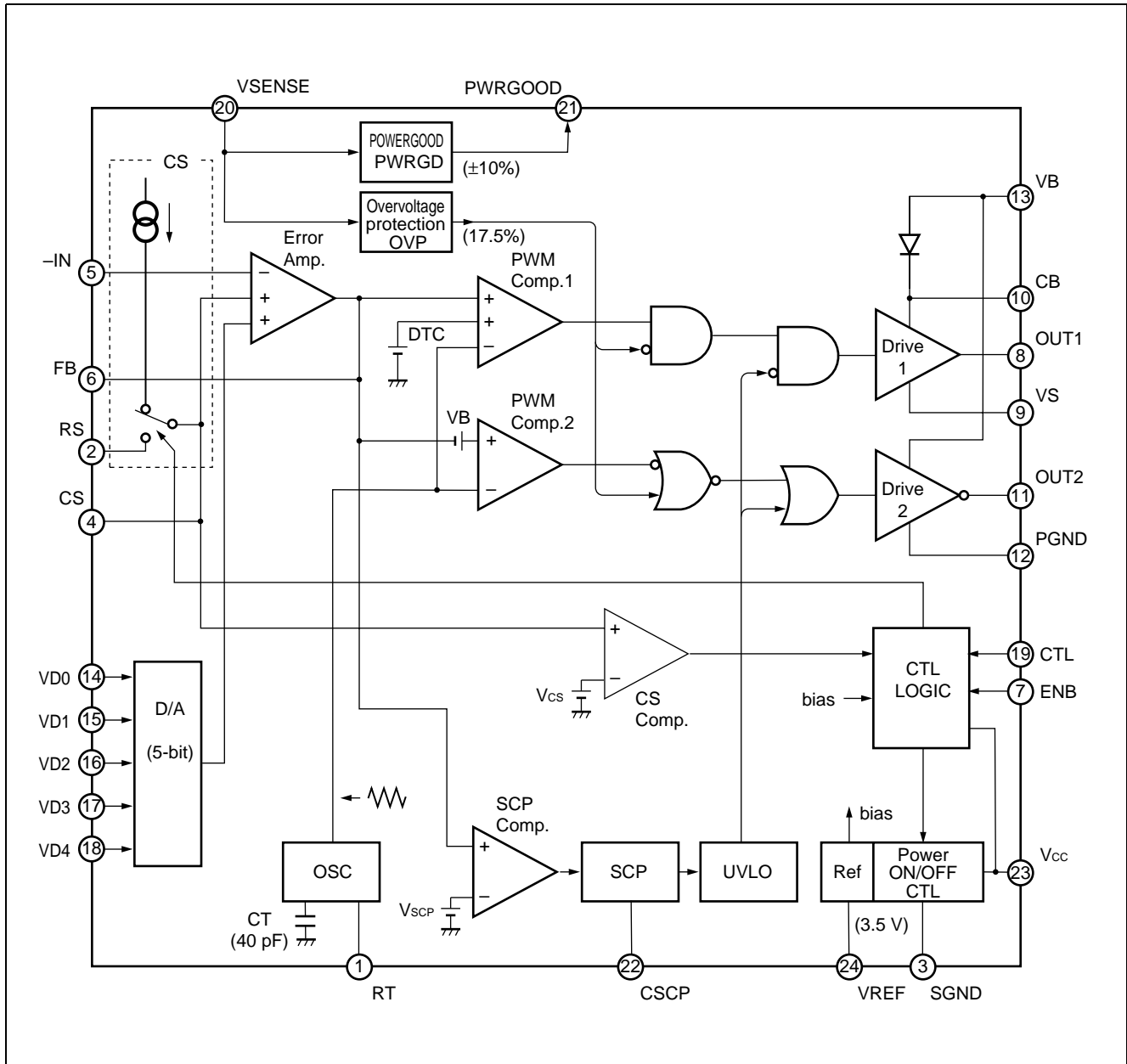

■ OUTPUT VOLTAGE SETTING CODE

VD4	VD3	VD2	VD1	VD0	VD (DC/DC converter output voltage) (V)
1	0	0	0	0	3.500
1	0	0	0	1	3.400
1	0	0	1	0	3.300
1	0	0	1	1	3.200
1	0	1	0	0	3.100
1	0	1	0	1	3.000
1	0	1	1	0	2.900
1	0	1	1	1	2.800
1	1	0	0	0	2.700
1	1	0	0	1	2.600
1	1	0	1	0	2.500
1	1	0	1	1	2.400
1	1	1	0	0	2.300
1	1	1	0	1	2.200
1	1	1	1	0	2.100
1	1	1	1	1	0 (output OFF)
0	0	0	0	0	2.050
0	0	0	0	1	2.000
0	0	0	1	0	1.950
0	0	0	1	1	1.900
0	0	1	0	0	1.850
0	0	1	0	1	1.800
0	0	1	1	0	1.750
0	0	1	1	1	1.700
0	1	0	0	0	1.650
0	1	0	0	1	1.600
0	1	0	1	0	1.550
0	1	0	1	1	1.500
0	1	1	0	0	1.450
0	1	1	0	1	1.400
0	1	1	1	0	1.350
0	1	1	1	1	1.300

MB3828

■ ABSOLUTE MAXIMUM RATINGS

Parameter	Symbol	Condition	Value	Unit
Power supply voltage	V _{CC}	—	20	V
Bias voltage	V _B	—	20	V
Boot voltage	V _{CB}	—	32	V
Control input voltage	V _{CTL}	—	20	V
PWRGOOD output voltage	V _{PWRGD}	—	17	V
Output current	I _O	—	50	mA
Peak output current	I _O	Duty ≤ 5% (t = 1/f _{osc} × Duty)	500	mA
Allowable dissipation	P _D	T _a ≤ +25°C	740*	mW
Storage temperature	T _{stg}	—	−55 to +125	°C

* : When mounted on a 10 cm-square dual-sided epoxy base board

WARNING: Semiconductor devices can be permanently damaged by application of stress (voltage, current, temperature, etc.) in excess of absolute maximum ratings. Do not exceed these ratings.

■ RECOMMENDED OPERATING CONDITIONS

Parameter	Symbol	Condition	Value			Unit
			Min.	Typ.	Max.	
Power supply voltage	V _{CC}	—	4.6	5	18	V
Bias voltage	V _B	—	—	5	18	V
Boot voltage	V _{CB}	—	—	—	30	V
Reference voltage output current	I _{OR}	—	-1	—	0	mA
Input voltage	V _{IN}	-IN pin	0	—	V _{CC} - 0.9	V
	V _{IN}	CTL, ENB, VD4 to VD0 pins	0	—	18	V
	V _{IN}	VSENSE	0	—	V _{CC}	V
Output current	I _O	OUT pin	-30	—	30	mA
	I _{PG}	PWRGOOD pin	—	—	1	mA
Peak output current	I _O	Duty ≤ 5% (t = 1/f _{OSC} × Duty)	-300	—	300	mA
Oscillator frequency	f _{OSC}	—	100	200	500	kHz
Timing resistance	R _T	—	51	130	270	kΩ
Boot capacitance	C _B	—	—	0.1	1.0	μF
Reference voltage output capacitance	C _{REF}	—	—	0.1	1.0	μF
Soft start capacitance	C _S	—	—	4700	10000	pF
Discharge control resistance	R _S	—	—	100	470	kΩ
Short detection capacitance	C _{SCP}	—	—	2200	10000	pF
Operating temperature	T _a	—	-30	+25	+85	°C

WARNING: The recommended operating conditions are required in order to ensure the normal operation of the semiconductor device. All of the device's electrical characteristics are warranted when the device is operated within these ranges.

Always use semiconductor devices within the recommended operating conditions. Operation outside these ranges may adversely affect reliability and could result in device failure.

No warranty is made with respect to uses, operating conditions, or combinations not represented on the data sheet. Users considering application outside the listed conditions are advised to contact their FUJITSU representative beforehand.

■ ELECTRICAL CHARACTERISTICS

(Ta = +25°C, Vcc = 5 V)

Parameter	Symbol	Pin no.	Condition	Value			Unit	
				Min.	Typ.	Max.		
Reference voltage block (Ref)	Output voltage	V _{REF}	24	V _{REF} = 0 mA	3.465	3.500	3.535	V
	Output voltage temperature regulation	$\frac{\Delta V_{REF}}{V_{REF}}$	24	Ta = -30°C to +85°C*	—	0.5	—	%
	Input stability	Line	24	V _{CC} = 4.6 V to 18 V	—	1	10	mV
	Load stability	Load	24	I _o = 0 mA to -1 mA	—	3	10	mV
	Short circuit output current	I _{OS}	24	V _{REF} = 1 V	-20	-10	-3	mA
Under voltage lockout circuit block (UVLO)	Threshold voltage	V _{TH}	4	V _{CC} = \square	3.4	3.7	4.0	V
	Hysteresis voltage	V _H	4	—	—	0.18	0.21	V
	Reset voltage	V _{RST}	4	—	1.7	2.1	—	V
Soft start block (CS)	Charge current	I _{CS}	4	—	-2.8	-2.0	-1.2	μA
Short circuit protection comparator block (SCP)	Threshold voltage	V _{TH}	4	—	0.63	0.68	0.73	V
	Input source current	I _{CSCP}	22	—	-2.8	-2.0	-1.2	μA
	Short detection interval	t _{SCP}	22	CSCP = 2200 pF	0.50	0.75	1.34	ms
Triangular wave oscillator block (OSC)	Oscillator frequency	f _{OSC}	8, 11	R _T = 130 kΩ	180	200	220	kHz
	Frequency temperature regulation	$\Delta f/f_{dt}$	8, 11	Ta = -30°C to +85°C*	—	1	—	%
Error amplifier block (Error Amp.)	Threshold voltage	V _{TH1}	6	FB = 1.6 V, VD4 to VD0 = 00101	1.7784	1.8000	1.8216	V
		V _{TH2}	6	FB = 1.6 V, VD4 to VD0 = 11010	2.4700	2.5000	2.5300	V
	V _{TH} temperature regulation	$\Delta V_T/V_T$	6	Ta = -30°C to +85°C*	—	0.5	—	%
	Input bias current	I _B	5	-IN = 0 V	-200	-50	—	nA
	Voltage gain	A _V	6	DC	60	100	—	dB
	Frequency bandwidth	BW	6	A _V = 0 dB*	—	800	—	kHz
	Output voltage	V _{OH}	6	—	2.18	3.5	—	V
		V _{OL}	6	—	—	0.8	1.0	V
	Output source current	I _{SOURCE}	6	FB = 1.6 V	—	-90	-45	μA
Output sink current	I _{SINK}	6	FB = 1.6 V	3.0	12.0	—	mA	

* : Standard design value

(Continued)

(Ta = +25°C, Vcc = 5 V)

Parameter		Symbol	Pin no.	Condition	Value			Unit
					Min.	Typ.	Max.	
PWM comparator blocks (PWM Comp.1, 2)	Threshold voltage	V _{TL}	8, 11	Duty cycle = 0%	1.2	1.3	—	V
		V _{TH}	8, 11	Duty cycle = Dtr	—	1.86	2.0	V
Dead time control block (DTC)	Maximum duty cycle	Dtr	8	R _T = 130 kΩ	85	90	95	%
Output blocks (Drive1, 2)	Output voltage (main side)	V _{OH}	8	OUT1 = -30 mA, VB = 5 V, CB = 20 V, VS = 15 V	CB - 1.4	CB - 1.1	—	V
		V _{OL}	8	OUT1 = 30 mA, VB = 5 V, CB = 22 V, VS = 15 V	—	VS + 1.1	VS + 1.4	V
	Output voltage (synchronized rectifier side)	V _{OH}	11	OUT2 = -30 mA, VB = 5 V	VB - 1.4	VB - 1.1	—	V
		V _{OL}	11	OUT2 = 30 mA, VB = 5 V	—	0.1	0.5	V
	Diode voltage	V _{DIODE}	13	I _{DIODE} = 10 mA	—	1.0	1.1	V
Control block (CTL)	CTL input voltage	V _{IH}	24	IC operating mode	2.0	—	18	V
		V _{IL}	24	IC standby mode	0	—	1.0	V
	Input current	I _{CTL}	19	CTL = 5 V	—	100	160	μA
PWRGOOD comparator protection block (PWRGD)	Threshold voltage	V _{TLOW}	21	VD4 to VD0 setting, VSENSE = \int	0.88 × VD	0.90 × VD	0.92 × VD	V
		V _{THIGH}	21	VD4 to VD0 setting, VSENSE = \int	1.08 × VD	1.10 × VD	1.12 × VD	V
	Hysteresis voltage	V _H	21	—	3	30	50	mV
	Output leak current	I _{LEAK}	21	PWRGOOD = 5 V	—	—	40	μA
	Output voltage	V _{OL}	21	PWRGOOD = 1 mA	—	0.06	0.4	V
Discharge control comparator (CS Comp.)	Threshold voltage	V _{TH}	24	CS = \int	—	0.05	0.07	V
Discharge control ON/OFF block (CTL LOGIC)	ENB input voltage	V _{IH}	24	Discharge control ON	2.0	—	18	V
		V _{IL}	24	Discharge control OFF	0	—	1.0	V
	Input current	I _{ENB}	7	ENB = 0 V	-1.0	-0.05	—	μA

(Continued)

MB3828

(Continued)

(Ta = +25°C, Vcc = 5 V)

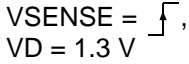
Parameter		Symbol	Pin no.	Condition	Value			Unit
					Min.	Typ.	Max.	
Over voltage protection comparator block (OVP)	Threshold voltage	V _{TH}	8, 11	V _{SENSE} =  , VD = 1.3 V	1.15 × VD	1.175 × VD	1.20 × VD	V
	Hysteresis voltage	V _H	8, 11	—	3	30	50	mV
	V _{SENSE} pin input current	I _{SENSE}	20	V _{SENSE} = 0 V	-10	-0.1	—	μA
D/A (VD4 to VD0 pin) (D/A)	D/A input voltage	V _{IH}	14 to 18	—	2.0	—	18	V
	D/A input voltage	V _{IL}	14 to 18	—	0	—	1.0	V
	Input current	I _D	14 to 18	VD4 to VD0 = 5 V	—	0.05	1.0	μA
General	Standby current	I _{CCS}	23	CTL = 0 V	—	0	10	μA
	Power supply current	I _{CC}	23	—	—	4.0	6.0	mA

■ TYPICAL CHARACTERISTICS

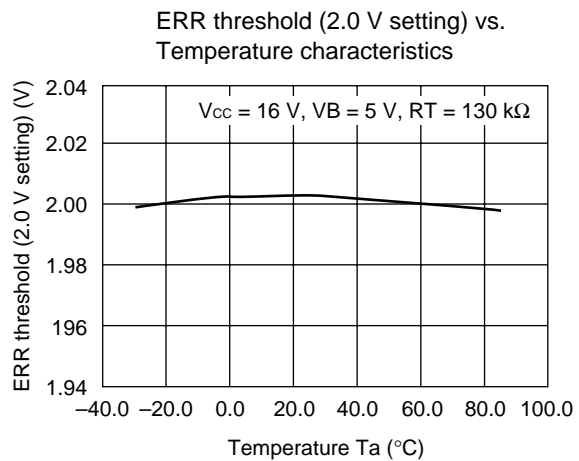
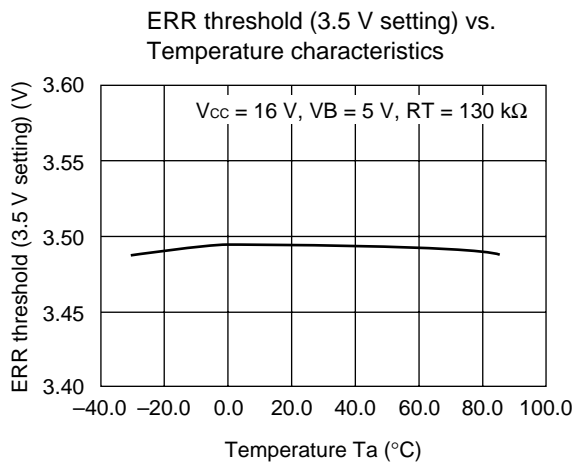
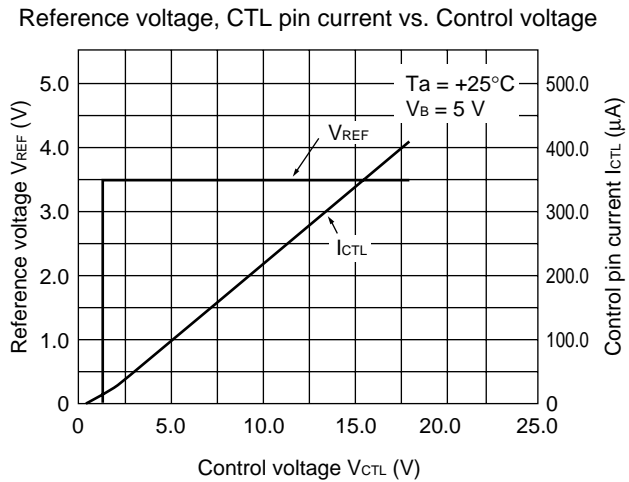
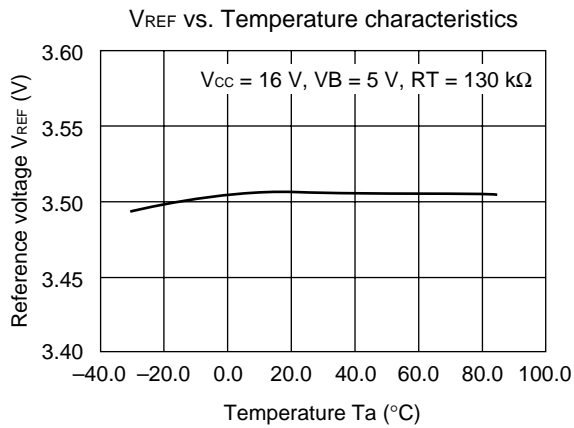
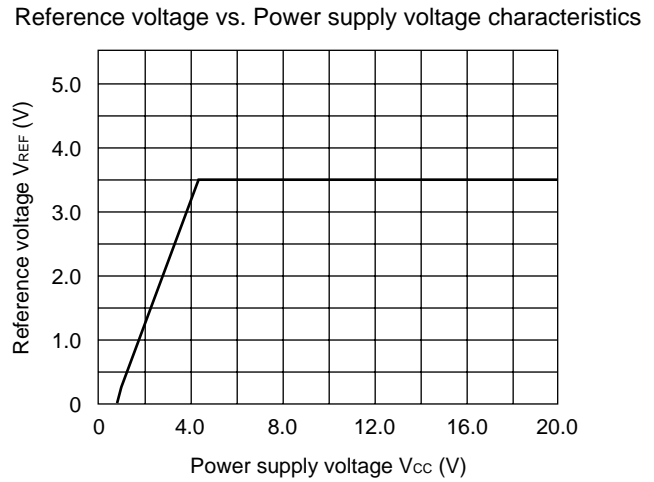
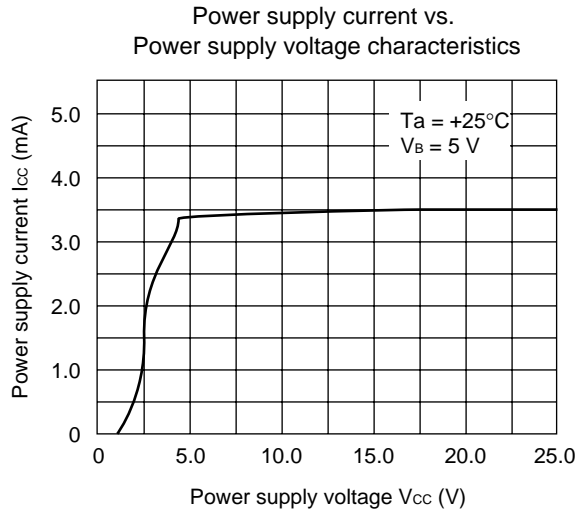

(Continued)

ERR threshold (1.3 V setting) vs. Temperature characteristics

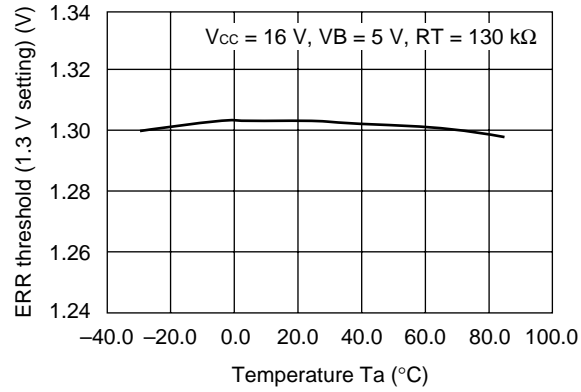

Error Amp. gain, Phase vs. Frequency characteristics

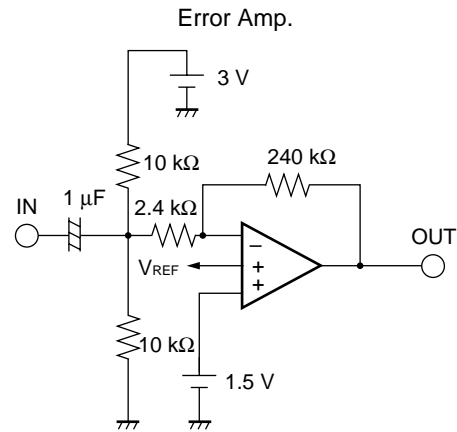
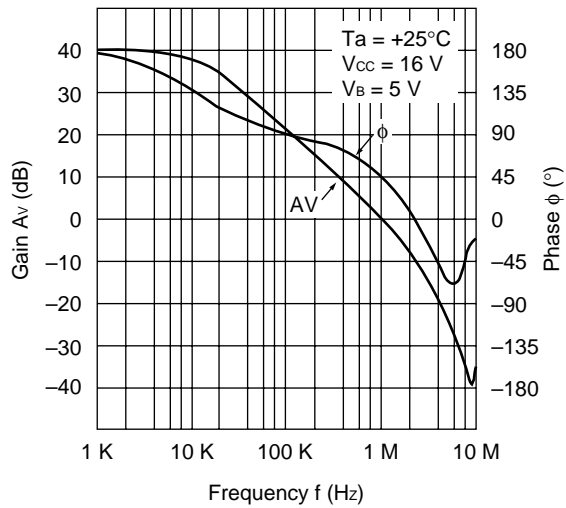

(Continued)

(Continued)

Triangular wave oscillator frequency vs. Power supply voltage characteristics

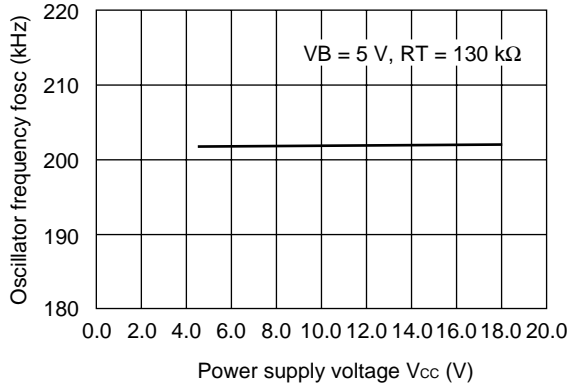

Triangular wave oscillator frequency vs. Timing resistance characteristics

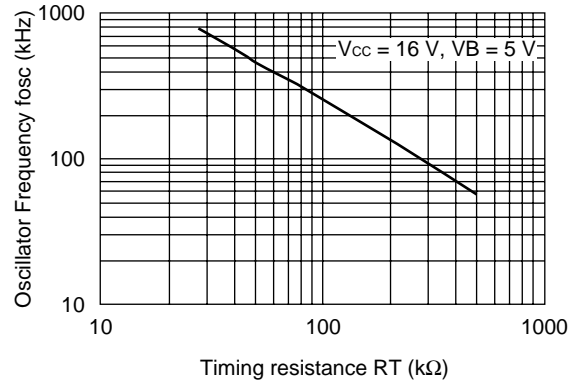

Triangular wave oscillator frequency vs. Temperature characteristics

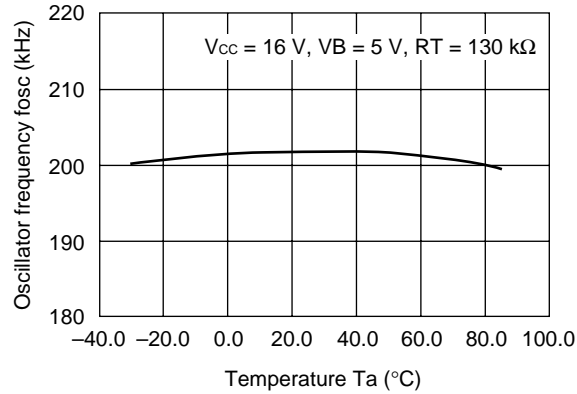

■ FUNCTION DESCRIPTION

1. Switching Regulator Function

(1) Reference voltage circuit (Ref)

The reference voltage circuit uses the voltage supply from the V_{CC} pin (pin 23) to generate a temperature compensated reference voltage ($\cong 3.5$ V) for use as the reference voltage for the internal circuits of the IC chip. It is also possible to supply a reference voltage output of up to 1 mA to external circuits through the VREF pin (pin 24).

(2) Triangular wave oscillator (OSC)

The triangular wave form is generated using an on-chip frequency selection capacitor, plus the frequency selection resistance connected to the RT pin (pin 1).

The triangular wave is input to the PWM comparator circuits on the IC.

(3) Error amplifier (Error Amp.)

The error amplifier circuit is used to detect the output voltage from the DC/DC converter for output as the PWM control signal. The in-phase input range covers the full range from 0 V to $V_{CC} - 0.9$ V. By connecting a feedback resistance and capacitor between the FB pin (pin 6) and $-IN$ pin (pin 5), it is possible to create any desired level of loop gain, thereby providing stable phase compensation to the system.

Also, it is possible to prevent current spikes at power supply start-up by connecting a soft start capacitor to the CS pin (pin 4), the non-inverting input pin for Error Amp. The use of Error Amp. for soft start detection makes it possible for a system to operate on a fixed soft start time that is independent of the output load on the DC/DC converter.

(4) PWM comparators (PWM Comp.1, PWM Comp.2)

PWM Comp.1 and PWM Comp.2 are voltage-pulse width converters that control output voltage according to input voltage.

PWM Comp.1 controls the pulse width on the main-side output circuit, and PWM Comp.2 controls the pulse width on the synchronous rectifier side output circuit.

The triangular wave generated by the triangular wave oscillator is compared with the output voltage from Error Amp., and during intervals when Error Amp. output is higher than the triangular wave, the main-side output transistor is switched on and the synchronous rectifier side output transistor is turned off.

PWM Comp.1 is set to a maximum duty cycle of approximately 90%.

(5) Output circuits (Drive1, Drive2)

The output circuits on both the main-side and synchronous rectifier-side have a totem-pole configuration, and are capable of driving an external N-ch. MOS FET.

(6) Power supply control circuit (CTL)

This circuit is able to control power supply ON/OFF switching from the CTL pin (pin 19). (During standby mode, supply current is 0 μ A TYP.)

(7) DAC circuit (D/A)

This circuit controls the output voltage to the CPU between 1.3 V and 3.5 V, as selected by the 5-bit (32-step) input signal information.

The output voltage can be set in 100 mV steps between 3.5 V and 2.1 V, and in 50 mV steps between 2.05 V and 1.3 V.

When all D/A input pins VD4 through VD0 (pin 18 through pin 14) are set to "H" level, the DC/DC converter output voltage is 0 V.

2. Protection Functions

(1) V_{CC} under voltage lockout circuit (UVLO)

Power surges at power-on, or momentary under-voltage situations can cause abnormal operation in the MB3828, which may lead to damage or deterioration in systems. This circuit prevents abnormal operation during times of low voltage by using the supply voltage to detect the level of the internal reference voltage, and fixes output pins OUT1 (pin 8) and OUT2 (pin 11) to “L” level. Once the supply voltage recovers to a level above the threshold voltage of the under voltage lockout circuit, operation is restored.

(2) Timer-latch short-circuit protection circuit (SCP)

This circuit detects the output voltage level from Error Amp. and activates the timer circuit, charging the external capacitor from the CSCP pin (pin 22) when Error Amp. output voltage level reaches or exceeds about 2.1 V. If Error Amp. output does not return to the normal voltage range before the capacitor voltage reaches about 0.68 V, the latch circuit is activated and the output pins (OUT1, OUT2) are held at “L” level. Once the protector circuit is activated, it can be reset by switching the power supply off and on again.

(3) Overvoltage protection circuit (OVP)

When the DC/DC converter output voltage (V_o) exceeds the output voltage set by the VD4 to VD0 pins by more than +17.5%, the overvoltage protection circuit output signal goes to “H” level causing one output pin (OUT1) to be held at “L” level and the other output pin (OUT2) to be held at “H” level.

(4) PWRGOOD comparator detection circuit (PWRGD)

The PWRGOOD pin (pin 21) outputs an “H” level signal as long as the VSENSE pin (pin 20) is receiving the DC/DC converter output voltage (V_o) within the range of 0.9 to 1.1 times the output voltage set by the VD4 to VD0 pins.

3. Soft Start/Discharge Control

(1) Soft start circuit (CS)

Connecting a capacitor to the CS pin (pin 4) prevents the inrush current at power turnon. Using an Error Amp. for detecting the soft error allows the soft start time to be initiated independent of output load from the DC/DC converter.

(2) Discharge control ON/OFF circuit (CTL LOGIC)

Entering an “L” level signal at the CTL pin while an “H” level signal is input at the ENB pin causes the discharge control ON/OFF circuit (CTL LOGIC) to switch the soft start circuit (CS) from charging to discharging.

The resistance (R_s) connected to the RS pin (pin 2) charges the soft start capacitor (C_s), so that Error Amp. provides control over the DC/DC converter output voltage in the same way as during a soft start. This makes it possible to control voltage drop independently of output load.

When the CS pin voltage reaches the discharge control comparator circuit (CS Comp.) threshold voltage ($\cong 50$ mV), the discharge control is canceled.

When an “L” level signal is input at the ENB pin (pin 7), the DC/DC converter output voltage discharge time control is switched OFF.

■ METHOD OF SETTING THE SOFT START TIME

At startup of the MB3828, the capacitor (C_s) connected to the CS pin begins charging. This produces a soft start, by providing output voltage from Error Amp. that is proportional to the CS pin voltage regardless of the DC/DC converter load current.

Soft start time (time to output setting voltage VD)

$$t_s (\text{sec}) \approx \frac{VD}{2 (\mu\text{A})} \times C_s (\mu\text{F})$$

■ TIME SETTING BY SHORT DETECTION

When load conditions change rapidly with the reduced output voltage, as when a load fault occurs, the Capacitor C_{SCP} connected to the CSCP pin (pin 22) is charged to threshold voltage ($V_{TH}=0.68\text{V}$) and sets a latch, the external FET is turned off (inactive interval 100%).

Short detection time

$$t_{PE} (\text{sec}) \approx 0.68 \times C_{SCP} (\mu\text{F}) / 2 (\mu\text{A})$$

■ OSCILLATOR FREQUENCY SETTING

The oscillator frequency can be set by connecting resistance to the RT pin (pin 1).

Oscillator frequency

$$f_{osc} (\text{kHz}) \approx 26250 / RT (\text{k}\Omega)$$

■ METHOD OF SETTING THE DISCHARGE TIME

- An "L" level CTL signal while the ENB pin is set to "H" level causes the resistance (R_s) connected to the RS pin to discharge electrical charge the capacitor (C_s) connected to the CS pin, causing the output voltage to fall gradually regardless of the DC/DC converter load current.

Discharge time (time to 0.05 V output voltage)

$$t_{off} (\text{msec}) \approx R_s (\text{k}\Omega) \times C_s (\mu\text{F}) \times \ln \left(\frac{VD}{V_{TH (CS COMP)}} \right)$$

- As long as the ENB pin is set to "L" level, the discharge control function is switched OFF.

■ D/A BLOCK VD4 to VD0 SWITCHING

- Switching of the VD4 to VD0 pin signal during the MB3828 operation may cause transient fluctuation in output voltage from the DC/DC converter. The resulting voltage instability may cause an "L" level from the PWRGOOD block, activating the OVP protection and shutting off the output from the DC/DC converter.

To switch VD4 to VD0 pin settings, first input an "L" level control signal to the CTL pin to place the MB3828 in standby status.

- When all VD4 to VD0 pin signals are set to "H" level, the DC/DC converter output is switched OFF.

■ PWRGOOD COMPARATOR CIRCUIT, OVP CIRCUIT OPERATION TIMING CHART

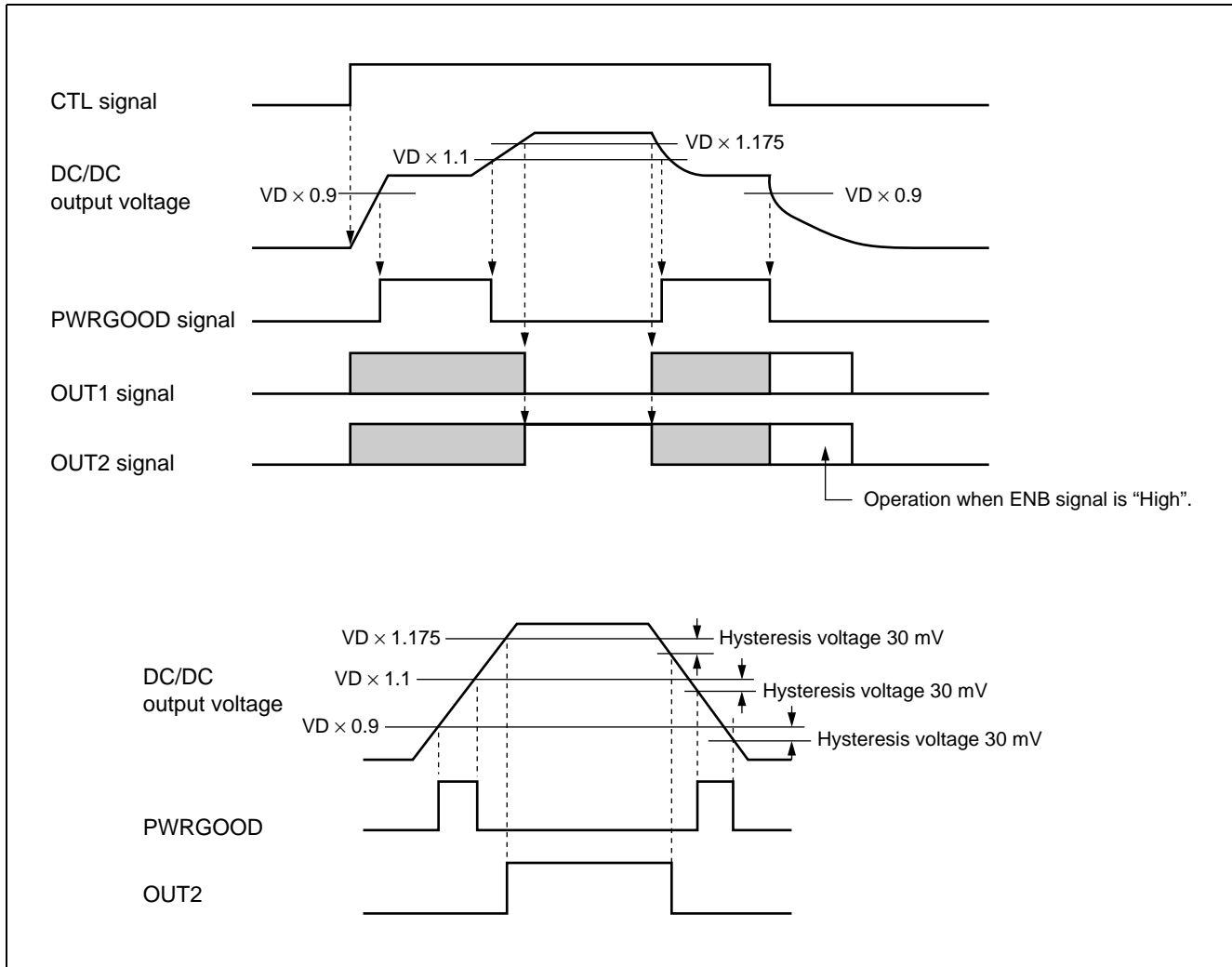

CTL LOGIC CIRCUIT OPERATION TIMING CHART

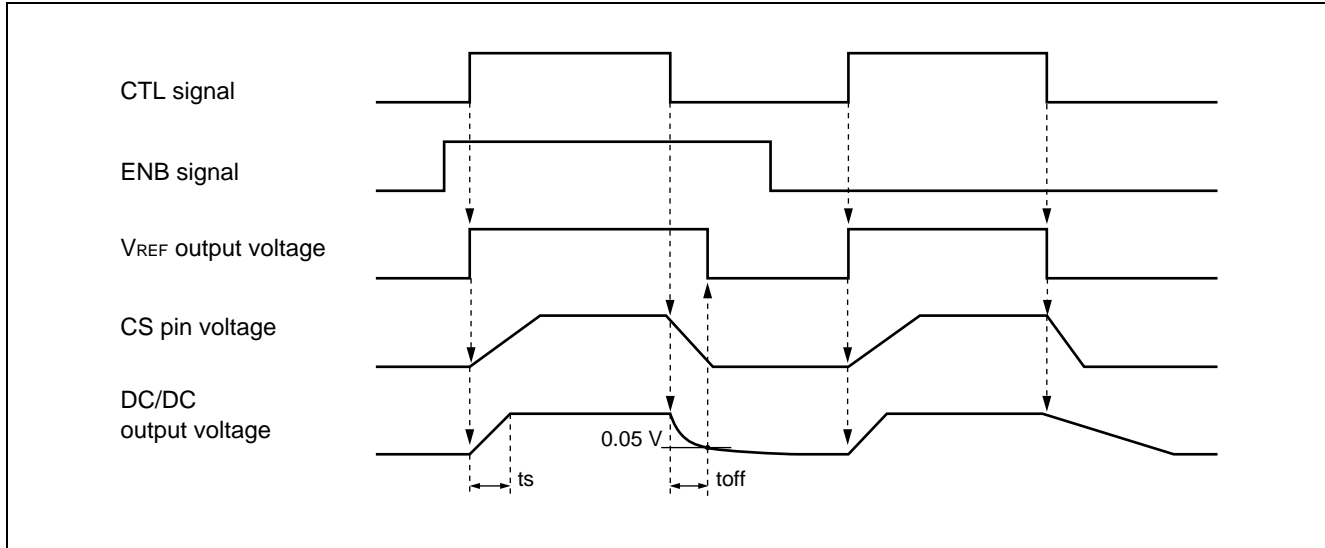

DC/DC CONVERTER INPUT VOLTAGE (V_{in}) AND V_B VOLTAGE SETTING

The voltage at the CB pin is bootstrapped from the VS pin voltage by an amount equivalent to the V_B pin voltage, as a result of the bootstrap capacitance (C_B) between the CB pin and VS pin. Therefore, either the V_{in} voltage or V_B pin voltage should be adjusted so that the sum of the DC/DC converter block input voltage V_{in} plus the V_B pin voltage does not exceed the recommended operating conditions for the CB pin boot voltage (V_{CB}).

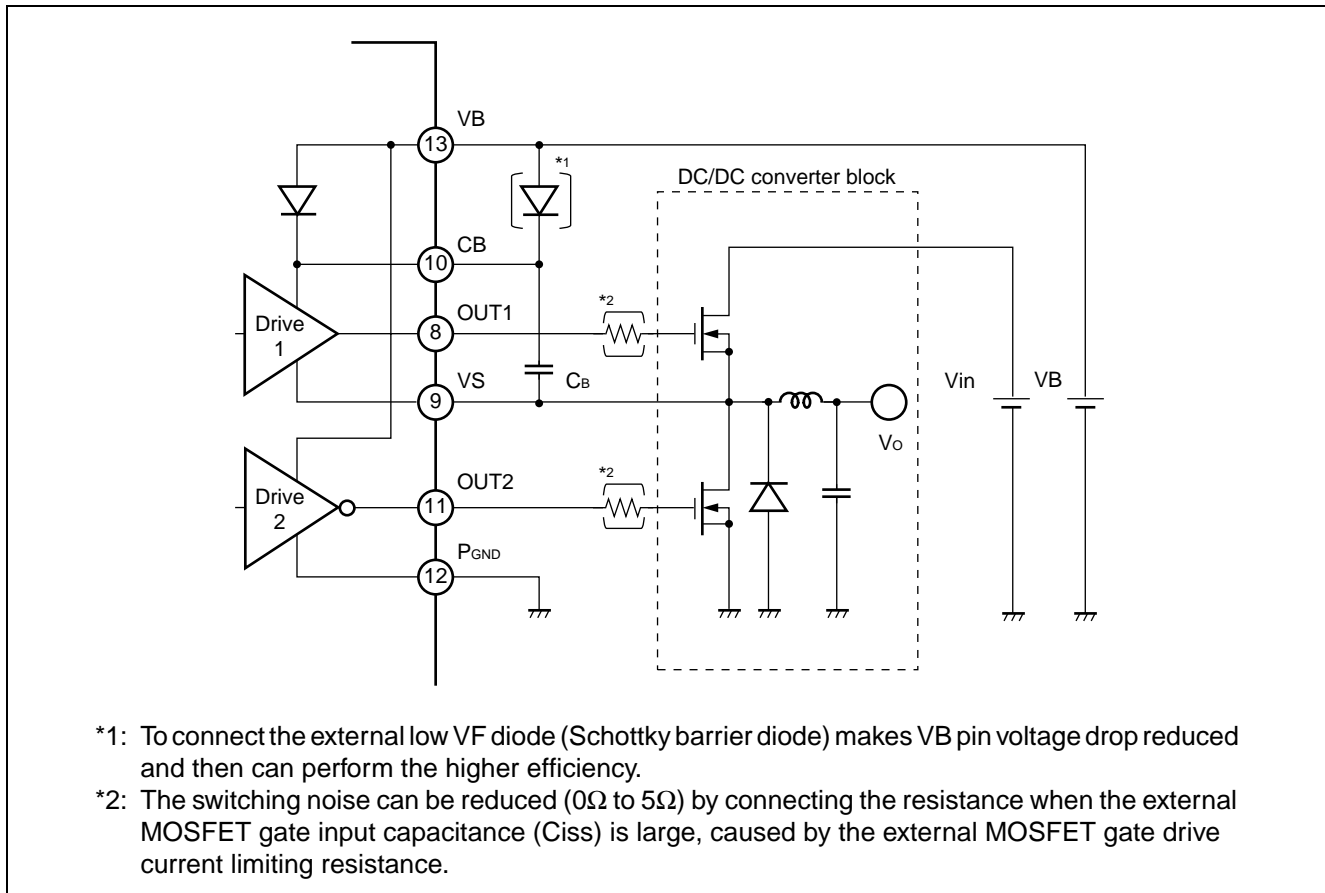

DC/DC CONVERTER SWITCHING OPERATION WAVEFORMS

<V_{CC} = 5 V, V_B = 5 V, V_{in} = 15V>

VD4–VD0 = 00101 (1.8 V)
load: 2 A
fosc = 200 kHz setting

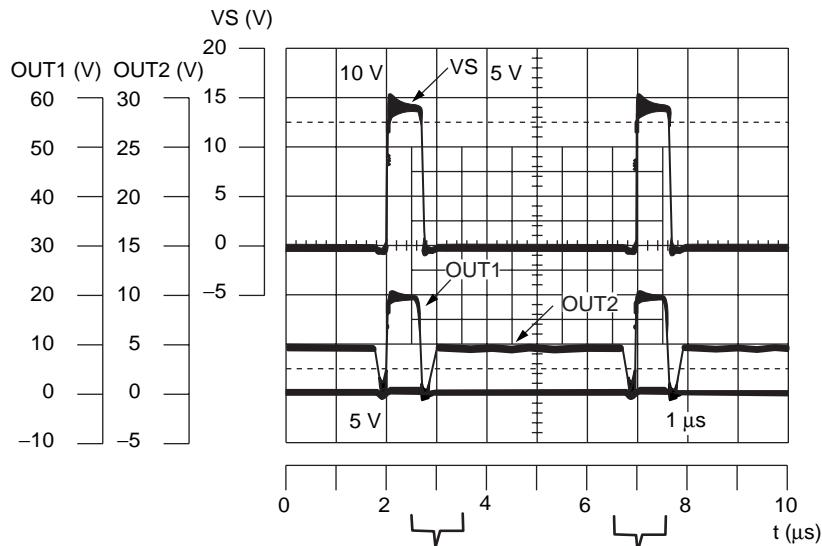

expansion

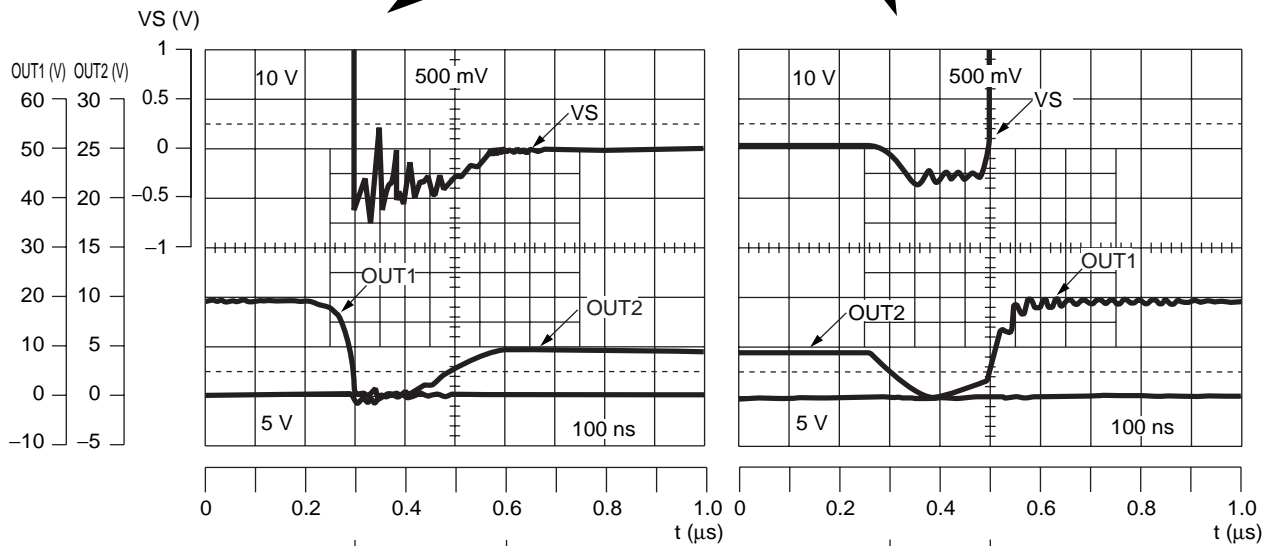

Synchronous rectifier length: 250 ns (typ)
OUT1 tf: 60 ns (typ)
OUT2 tr: 130 ns (typ)

Synchronous rectifier length: 200 ns (typ)
OUT1 tr: 130 ns (typ)
OUT2 tf: 100 ns (typ)

APPLICATION EXAMPLE

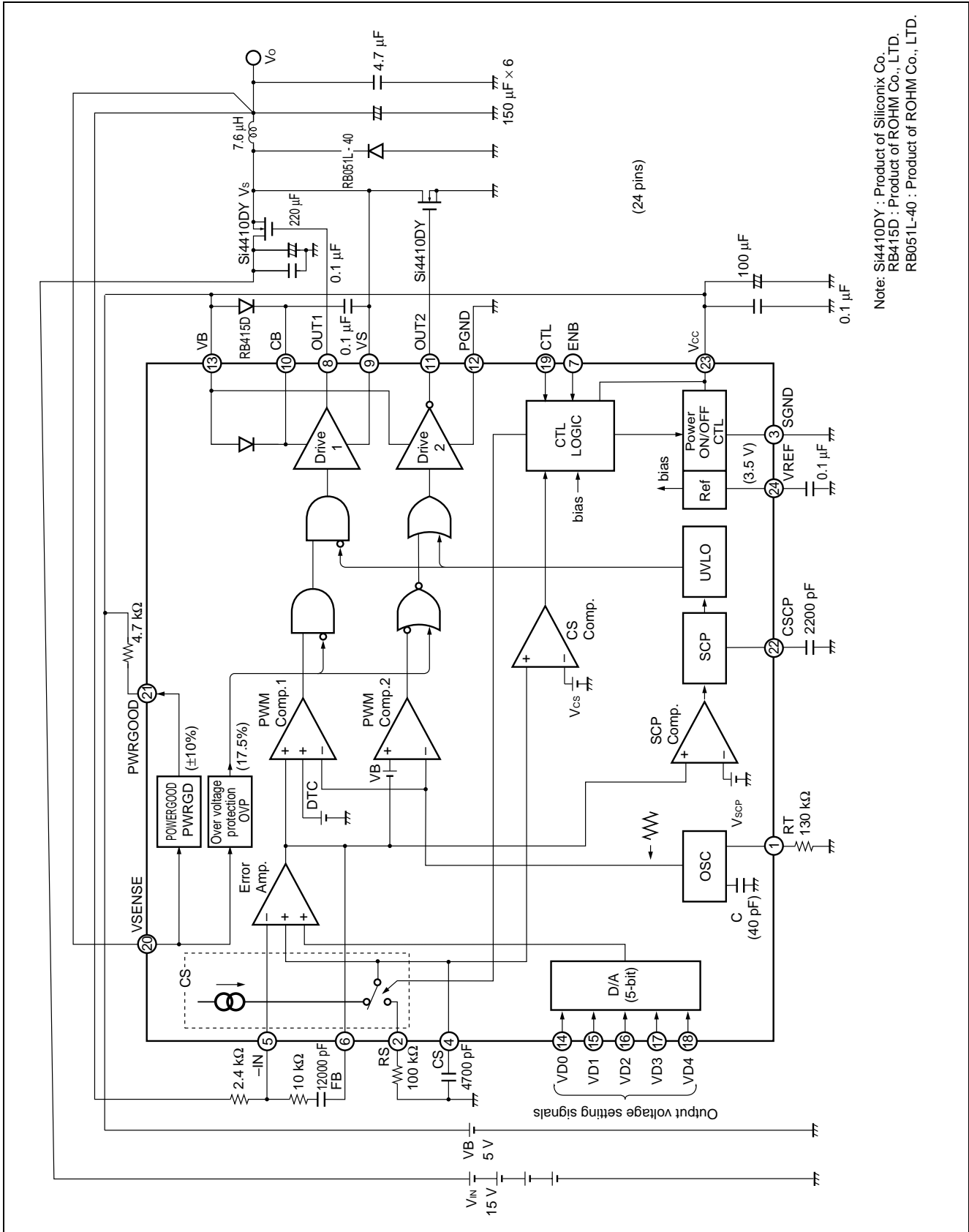

■ REFERENCE DATA

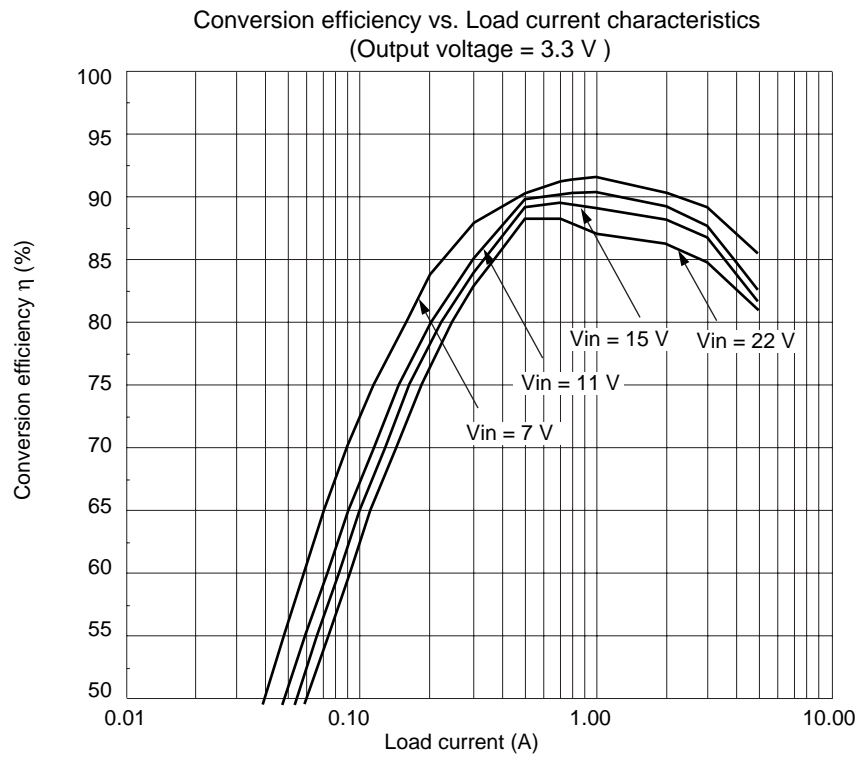
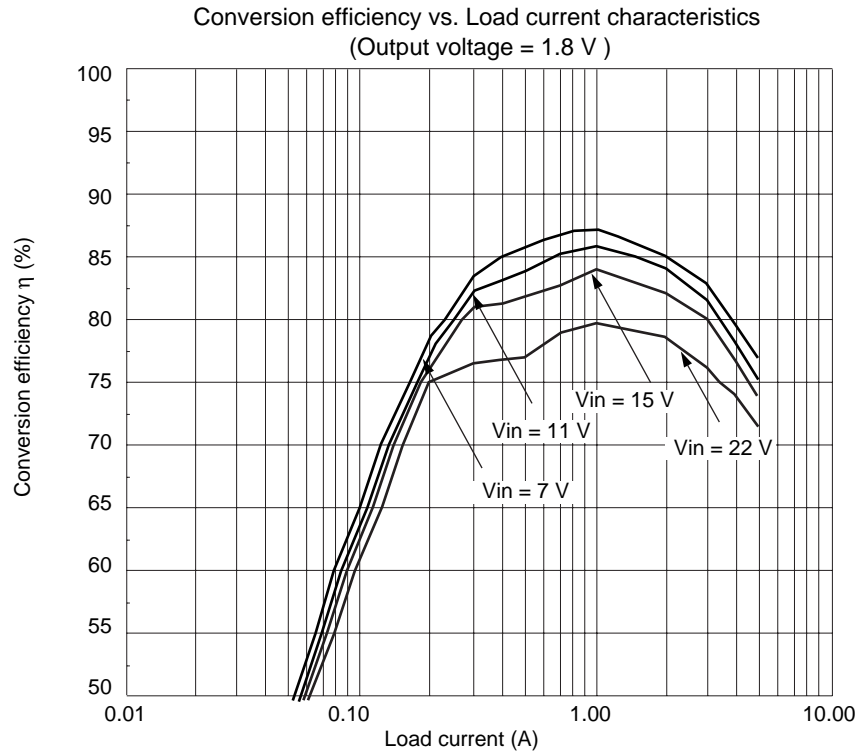

(Continued)

Transient response for CTL ON/OFF
< Output = 1.8 V, nonload >

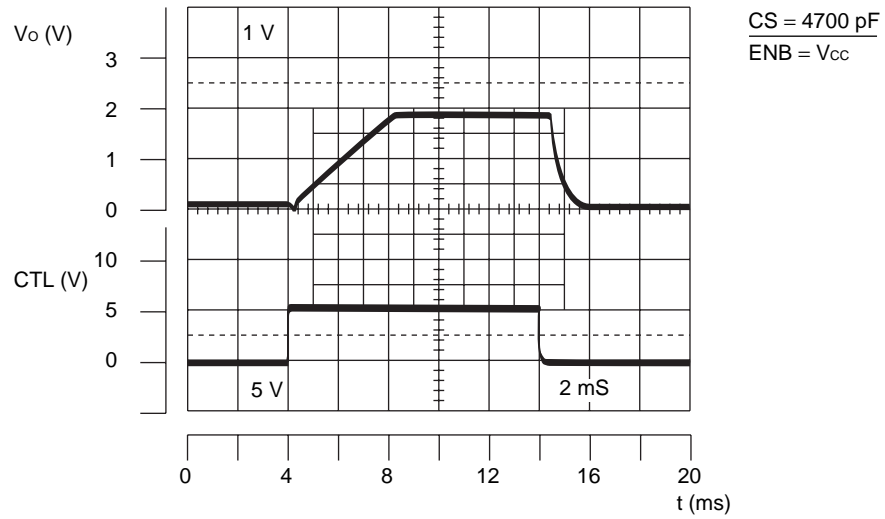

Transient response for CTL ON/OFF
< Output = 3.3 V, nonload >

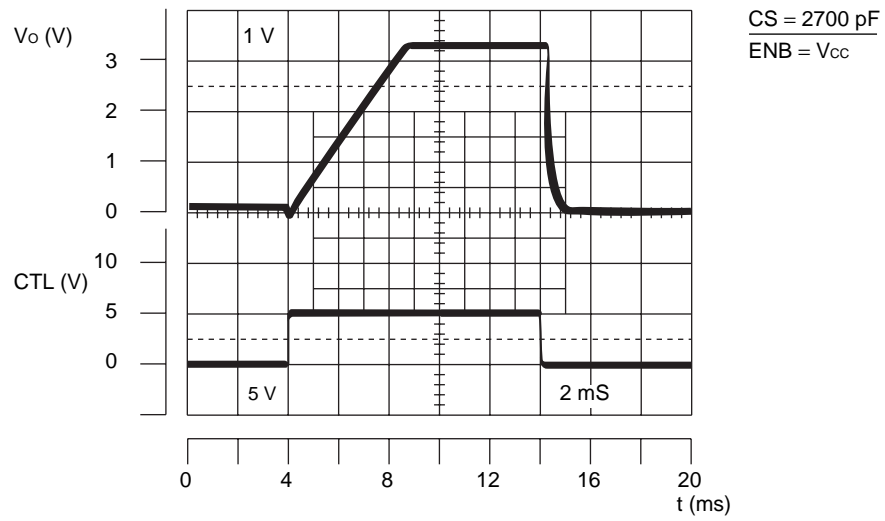

(Continued)

(Continued)

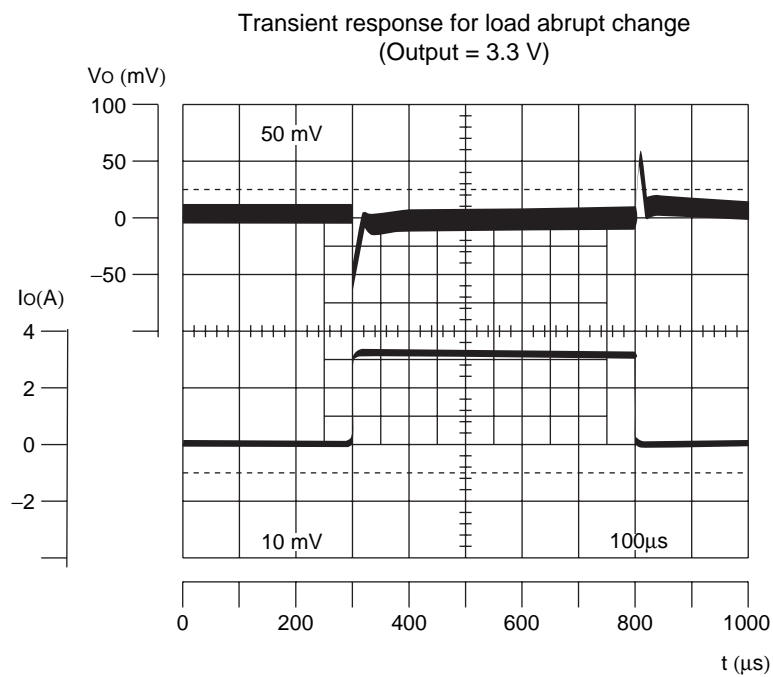
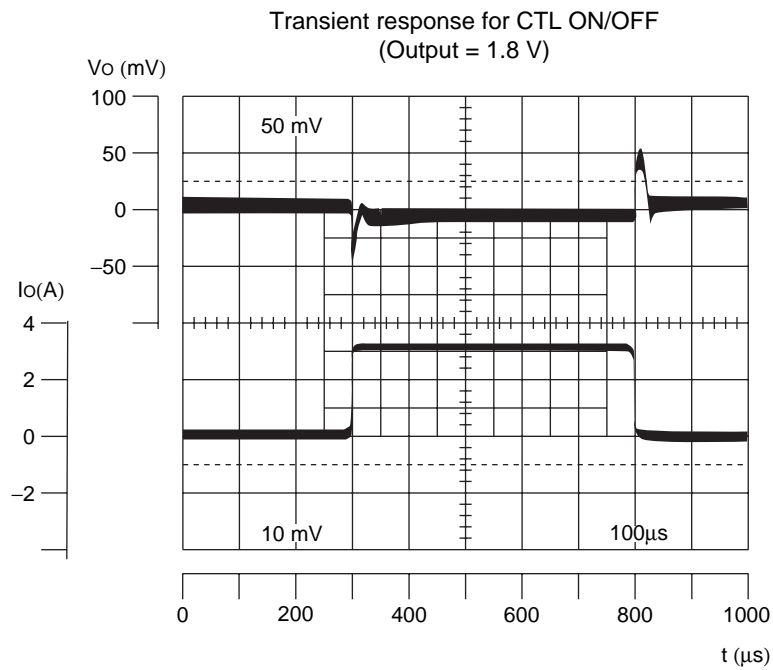

■ USAGE PRECAUTIONS

1. Device settings must not exceed absolute maximum ratings.

Usage under conditions exceeding absolute maximum ratings may permanently damage LSI devices.

Note also that in normal operation usage within recommended operating conditions is preferred, and that the reliability of LSI devices may be adversely affected when used outside these conditions.

2. Devices should be used within recommended operating conditions.

Recommended operating conditions are recommended values within which the LSI device is warranted to operate normally.

Rated values of electrical characteristics are warranted within the range of recommended operating conditions and within the conditions listed in the condition column for each parameter.

3. Printed circuit board ground lines should be designed in consideration of common impedance values.

4. Observe precautions against static electricity.

- Containers in which semiconductors are placed should either be protected against static electricity, or be of conductive material.
- After mounting of devices, use conductive bags or conductive containers when storing or transporting printed circuit boards.
- Working surfaces, tools and instruments should be properly grounded.
- Workers should be grounded by a ground line with 250 kΩ to 1 MΩ resistance in series between the worker and ground.

■ ORDERING INFORMATION

Part number	Package	Remarks
MB3828 PFV-G-BND	24-pin Plastic SSOP (FPT-24P-M03)	

■ PACKAGE DIMENSION

24-pin Plastic SSOP
(FPT-24P-M03)

*: These dimensions do not include resin protrusion.

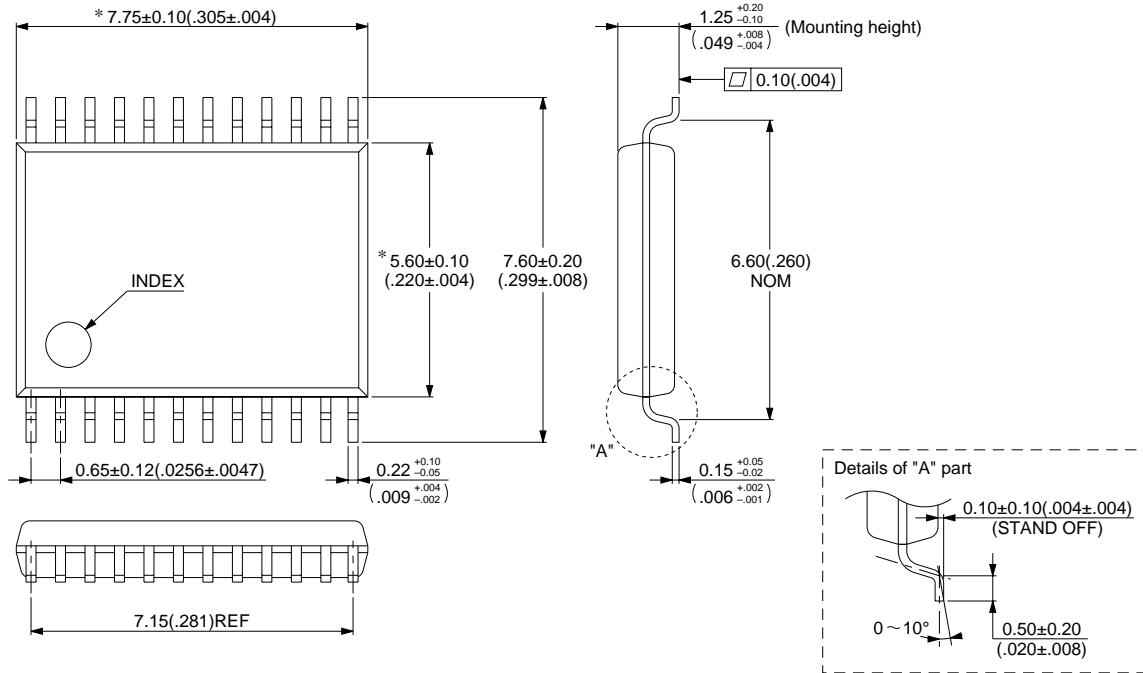

© 1994 FUJITSU LIMITED F24018S-2C-2

Dimensions in mm (inches)

FUJITSU LIMITED

For further information please contact:

Japan

FUJITSU LIMITED
Corporate Global Business Support Division
Electronic Devices
KAWASAKI PLANT, 4-1-1, Kamikodanaka
Nakahara-ku, Kawasaki-shi
Kanagawa 211-8588, Japan
Tel: 81(44) 754-3763
Fax: 81(44) 754-3329

<http://www.fujitsu.co.jp/>

North and South America

FUJITSU MICROELECTRONICS, INC.
Semiconductor Division
3545 North First Street
San Jose, CA 95134-1804, USA
Tel: (408) 922-9000
Fax: (408) 922-9179

Customer Response Center
Mon. - Fri.: 7 am - 5 pm (PST)
Tel: (800) 866-8608
Fax: (408) 922-9179

<http://www.fujitsumicro.com/>

Europe

FUJITSU MIKROELEKTRONIK GmbH
Am Siebenstein 6-10
D-63303 Dreieich-Buchsschlag
Germany
Tel: (06103) 690-0
Fax: (06103) 690-122

<http://www.fujitsu-edc.com/>

Asia Pacific

FUJITSU MICROELECTRONICS ASIA PTE LTD
#05-08, 151 Lorong Chuan
New Tech Park
Singapore 556741
Tel: (65) 281-0770
Fax: (65) 281-0220

<http://www.fmap.com.sg/>

F9903

© FUJITSU LIMITED Printed in Japan

All Rights Reserved.

The contents of this document are subject to change without notice. Customers are advised to consult with FUJITSU sales representatives before ordering.

The information and circuit diagrams in this document are presented as examples of semiconductor device applications, and are not intended to be incorporated in devices for actual use. Also, FUJITSU is unable to assume responsibility for infringement of any patent rights or other rights of third parties arising from the use of this information or circuit diagrams.

FUJITSU semiconductor devices are intended for use in standard applications (computers, office automation and other office equipment, industrial, communications, and measurement equipment, personal or household devices, etc.).

CAUTION:

Customers considering the use of our products in special applications where failure or abnormal operation may directly affect human lives or cause physical injury or property damage, or where extremely high levels of reliability are demanded (such as aerospace systems, atomic energy controls, sea floor repeaters, vehicle operating controls, medical devices for life support, etc.) are requested to consult with FUJITSU sales representatives before such use. The company will not be responsible for damages arising from such use without prior approval.

Any semiconductor devices have an inherent chance of failure. You must protect against injury, damage or loss from such failures by incorporating safety design measures into your facility and equipment such as redundancy, fire protection, and prevention of over-current levels and other abnormal operating conditions.

If any products described in this document represent goods or technologies subject to certain restrictions on export under the Foreign Exchange and Foreign Trade Law of Japan, the prior authorization by Japanese government will be required for export of those products from Japan.