

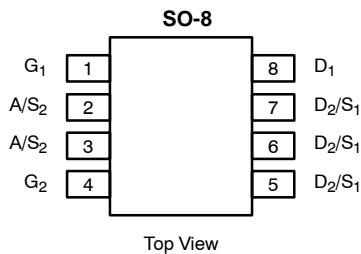

Dual N-Channel 30-V (D-S) MOSFET with Schottky Diode

PRODUCT SUMMARY				
	V _{DS} (V)	r _{DS(on)} (Ω)	I _D (A)	Q _g (Typ)
Channel-1	30	0.0185 @ V _{GS} = 10 V	6.8	7.8
		0.0225 @ V _{GS} = 4.5 V	6.0	
Channel-2		0.0115 @ V _{GS} = 10 V	11.4	11.6
		0.016 @ V _{GS} = 4.5 V	9.5	

SCHOTTKY PRODUCT SUMMARY		
V _{DS} (V)	V _{SD} (V) Diode Forward Voltage	I _F (A)
30	0.50 V @ 1.0 A	2.0



Ordering Information: Si4816BDY—E3
Si4816BDY-T1—E3 (with Tape and Reel)

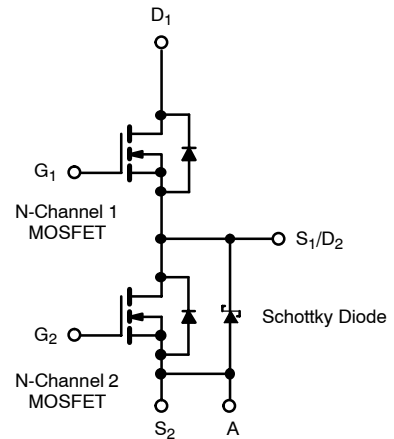

ABSOLUTE MAXIMUM RATINGS (T _A = 25°C UNLESS OTHERWISE NOTED)							
Parameter	Symbol	Channel-1		Channel-2		Unit	
		10 secs	Steady State	10 secs	Steady State		
Drain-Source Voltage	V _{DS}	30				V	
Gate-Source Voltage	V _{GS}	20					
Continuous Drain Current (T _J = 150°C) ^a	I _D	T _A = 25°C	6.8	5.8	11.4	8.2	A
		T _A = 70°C	5.5	4.6	9.0	6.5	
Pulsed Drain Current	I _{DM}	30		40		A	
Continuous Source Current (Diode Conduction) ^a	I _S	1	0.9	2.2	1.15		
Maximum Power Dissipation ^a	P _D	T _A = 25°C	1.4	1.0	2.4	1.25	W
		T _A = 70°C	0.9	0.64	1.5	0.8	
Operating Junction and Storage Temperature Range	T _J , T _{stg}	-55 to 150				°C	

THERMAL RESISTANCE RATINGS									
Parameter	Symbol	Channel-1		Channel-2		Schottky		Unit	
		Typ	Max	Typ	Max	Typ	Max		
Maximum Junction-to-Ambient ^a	R _{thJA}	t ≤ 10 sec	72	90	43	53	48	60	°C/W
		Steady-State	100	125	82	100	80	100	
Maximum Junction-to-Foot (Drain)	R _{thJF}	51	63	25	30	28	35		

Notes
a. Surface Mounted on 1" x 1" FR4 Board.

MOSFET SPECIFICATIONS ($T_J = 25^\circ\text{C}$ UNLESS OTHERWISE NOTED)							
Parameter	Symbol	Test Condition	Min	Typ ^a	Max	Unit	
Static							
Gate Threshold Voltage	$V_{GS(th)}$	$V_{DS} = V_{GS}, I_D = 250 \mu\text{A}$	Ch-1	1.0		3.0	V
			Ch-2	1.0		3.0	
Gate-Body Leakage	I_{GSS}	$V_{DS} = 0\text{ V}, V_{GS} = 20\text{ V}$	Ch-1			100	nA
			Ch-2			100	
Zero Gate Voltage Drain Current	I_{DSS}	$V_{DS} = 30\text{ V}, V_{GS} = 0\text{ V}$	Ch-1			1	μA
			Ch-2			100	
		$V_{DS} = 30\text{ V}, V_{GS} = 0\text{ V}, T_J = 85^\circ\text{C}$	Ch-1			15	
			Ch-2			2000	
On-State Drain Current ^b	$I_{D(on)}$	$V_{DS} = 5\text{ V}, V_{GS} = 10\text{ V}$	Ch-1	20			A
			Ch-2	30			
Drain-Source On-State Resistance ^b	$r_{DS(on)}$	$V_{GS} = 10\text{ V}, I_D = 6.8\text{ A}$	Ch-1		0.0155	0.0185	Ω
		$V_{GS} = 10\text{ V}, I_D = 11.4\text{ A}$	Ch-2		0.0093	0.0115	
		$V_{GS} = 4.5\text{ V}, I_D = 6.0\text{ A}$	Ch-1		0.0185	0.0225	
		$V_{GS} = 4.5\text{ V}, I_D = 9.5\text{ A}$	Ch-2		0.013	0.016	
Forward Transconductance ^b	g_{fs}	$V_{DS} = 15\text{ V}, I_D = 6.8\text{ A}$	Ch-1		30		S
		$V_{DS} = 15\text{ V}, I_D = 11.4\text{ A}$	Ch-2		31		
Diode Forward Voltage ^b	V_{SD}	$I_S = 1\text{ A}, V_{GS} = 0\text{ V}$	Ch-1		0.73	1.1	V
		$I_S = 1\text{ A}, V_{GS} = 0\text{ V}$	Ch-2		0.47	0.5	
Dynamic^a							
Total Gate Charge	Q_g	Channel-1 $V_{DS} = 15\text{ V}, V_{GS} = 5\text{ V}, I_D = 6.8\text{ A}$ Channel-2 $V_{DS} = 15\text{ V}, V_{GS} = 5\text{ V}, I_D = -11.4\text{ A}$	Ch-1		7.8	10	nC
			Ch-2		11.6	18	
Gate-Source Charge	Q_{gs}		Ch-1		2.9		nC
Gate-Drain Charge	Q_{gd}		Ch-2		4.8		
Gate Resistance	R_g		Ch-1	1.5	3.0	4.5	Ω
			Ch-2	0.9	1.8	2.7	
Turn-On Delay Time	$t_{d(on)}$		Ch-1		11	17	ns
Rise Time	t_r	Channel-1 $V_{DD} = 15\text{ V}, R_L = 15\ \Omega$ $I_D \cong 1\text{ A}, V_{GEN} = 10\text{ V}, R_g = 6\ \Omega$	Ch-2		13	20	
			Ch-1		9	15	
Turn-Off Delay Time	$t_{d(off)}$	Channel-2 $V_{DD} = 15\text{ V}, R_L = 15\ \Omega$ $I_D \cong 1\text{ A}, V_{GEN} = 10\text{ V}, R_g = 6\ \Omega$	Ch-2		9	15	
			Ch-1		24	40	
Fall Time	t_f		Ch-2		31	50	
			Ch-1		9	15	
Source-Drain Reverse Recovery Time	t_{rr}	$I_F = 1.3\text{ A}, di/dt = 100\text{ A}/\mu\text{s}$	Ch-2		11	17	
		$I_F = 2.2\text{ A}, di/dt = 100\ \mu\text{A}/\mu\text{s}$	Ch-1		20	35	
			Ch-2		25	40	

Notes

- a. Guaranteed by design, not subject to production testing.
b. Pulse test; pulse width $\leq 300\ \mu\text{s}$, duty cycle $\leq 2\%$.



SCHOTTKY SPECIFICATIONS (T_J = 25 °C UNLESS OTHERWISE NOTED)

Parameter	Symbol	Test Condition	Min	Typ	Max	Unit
Forward Voltage Drop	V _F	I _F = 1.0 A		0.47	0.50	V
		I _F = 1.0 A, T _J = 125 °C		0.36	0.42	
Maximum Reverse Leakage Current	I _{rm}	V _r = 30 V		0.004	0.100	mA
		V _r = 30 V, T _J = 100 °C		0.7	10	
		V _r = -30 V, T _J = 125 °C		3.0	20	
Junction Capacitance	C _T	V _r = 10 V		50		pF

Stresses beyond those listed under "Absolute Maximum Ratings" may cause permanent damage to the device. These are stress ratings only, and functional operation of the device at these or any other conditions beyond those indicated in the operational sections of the specifications is not implied. Exposure to absolute maximum rating conditions for extended periods may affect device reliability.

TYPICAL CHARACTERISTICS (25 °C UNLESS NOTED) CHANNEL-1

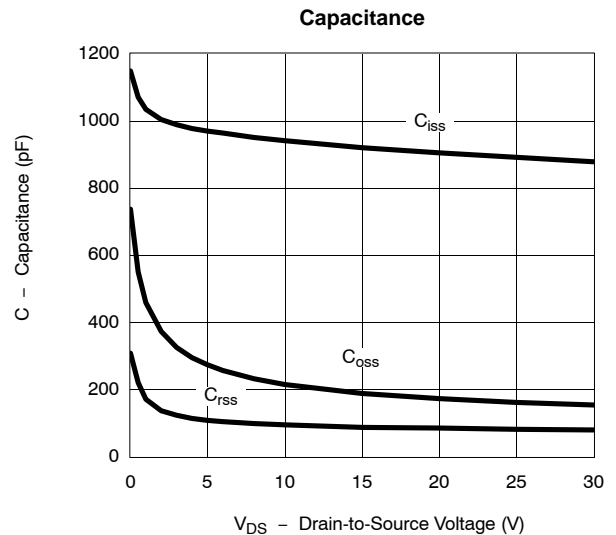
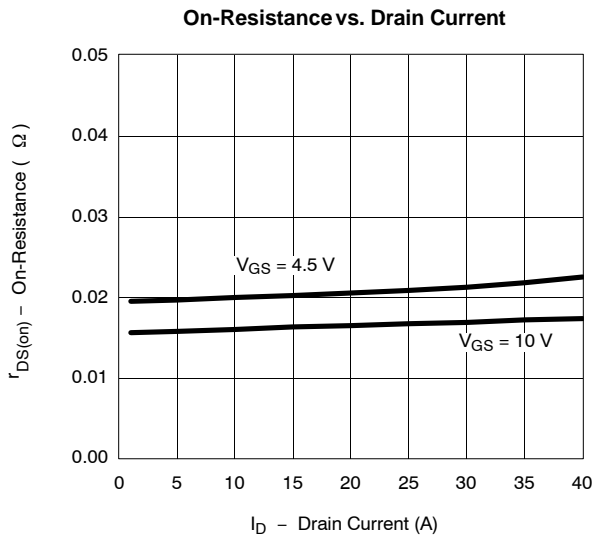
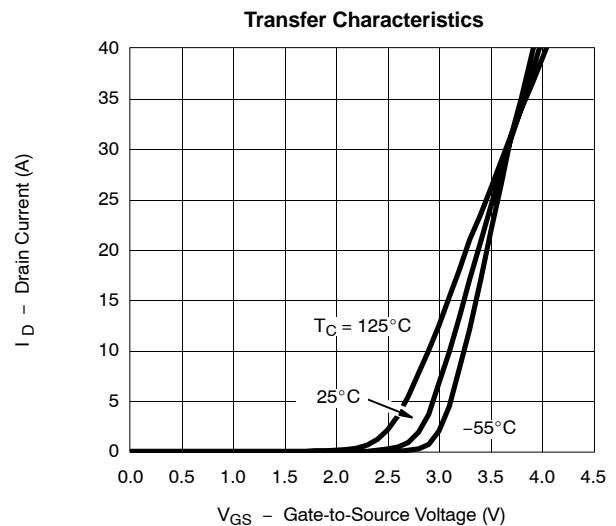
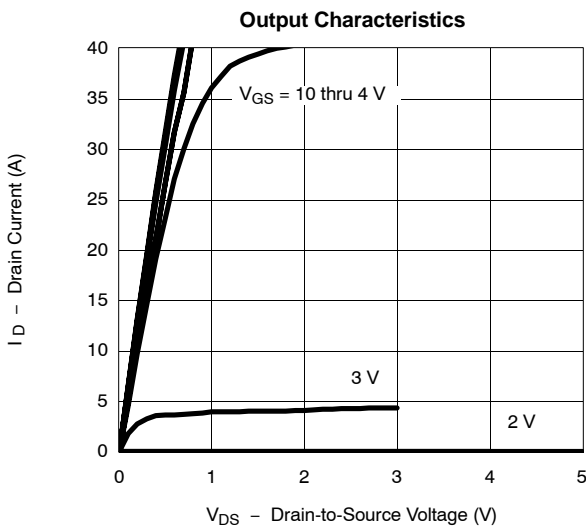

TYPICAL CHARACTERISTICS (25 °C UNLESS NOTED)

CHANNEL-1

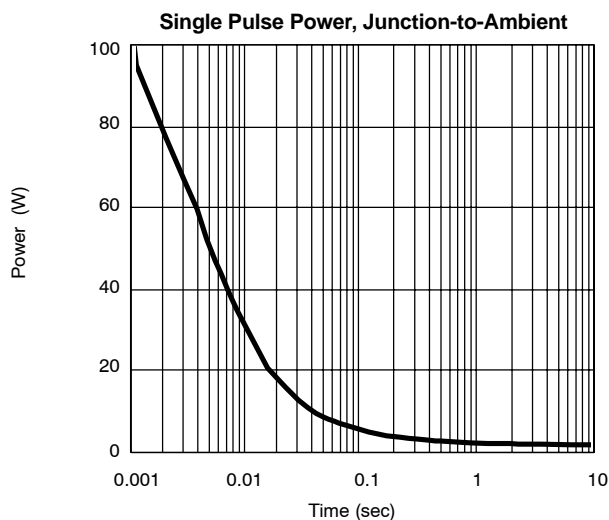
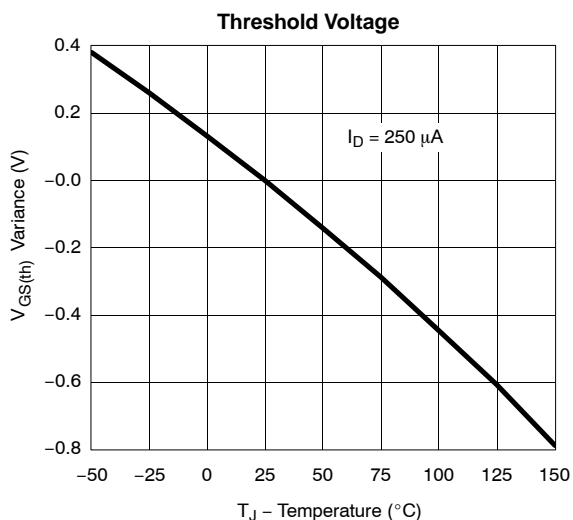
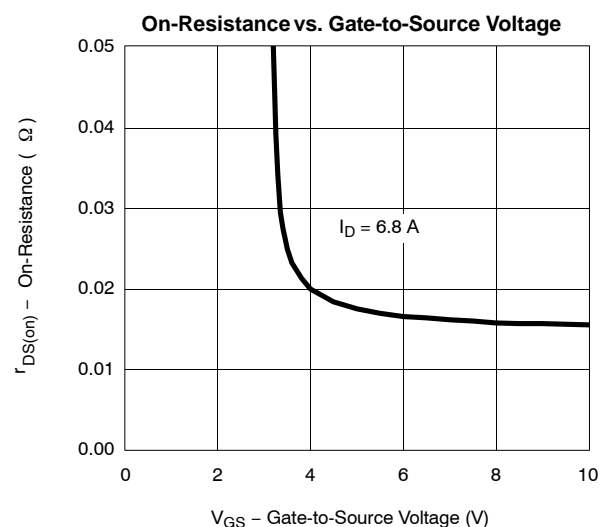
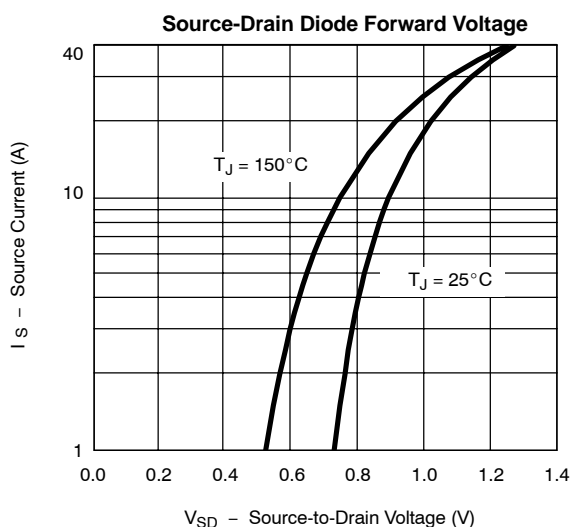
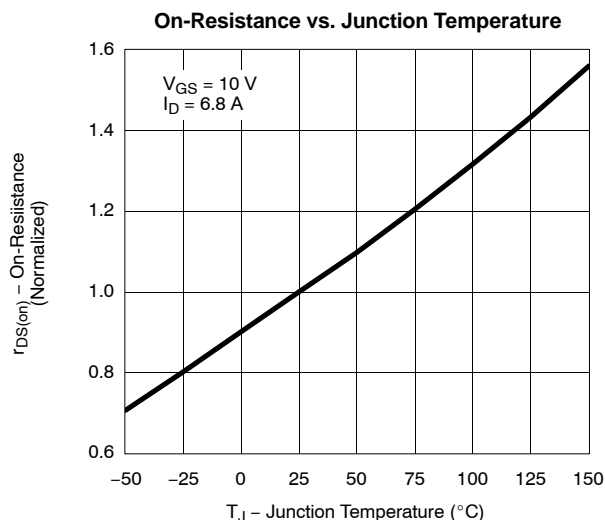
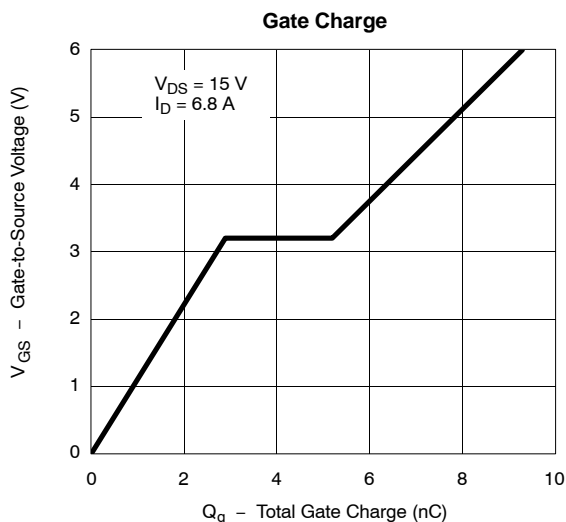



TYPICAL CHARACTERISTICS (25°C UNLESS NOTED) CHANNEL-1

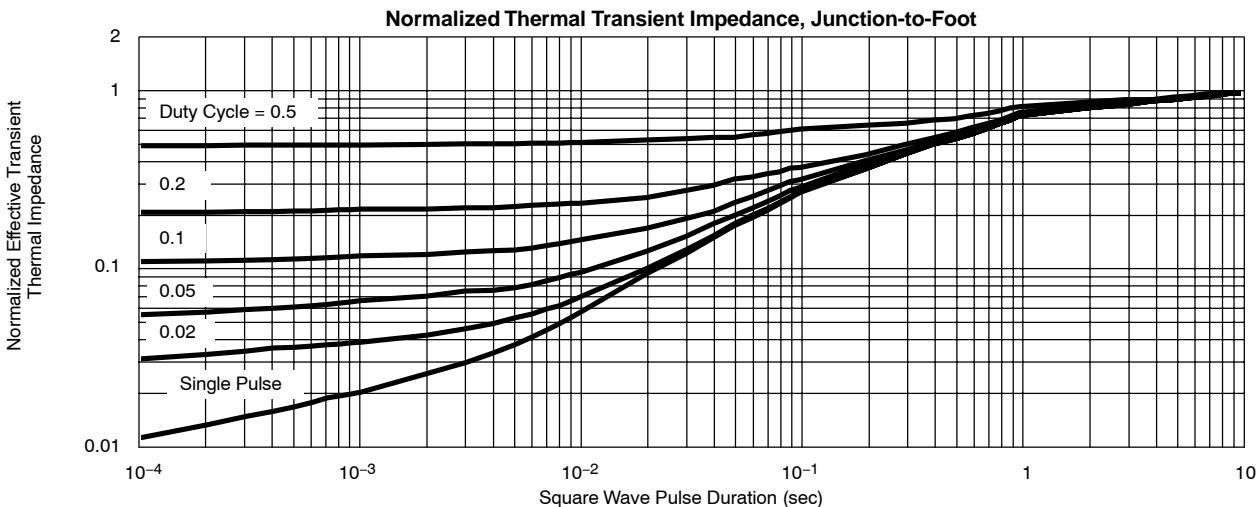
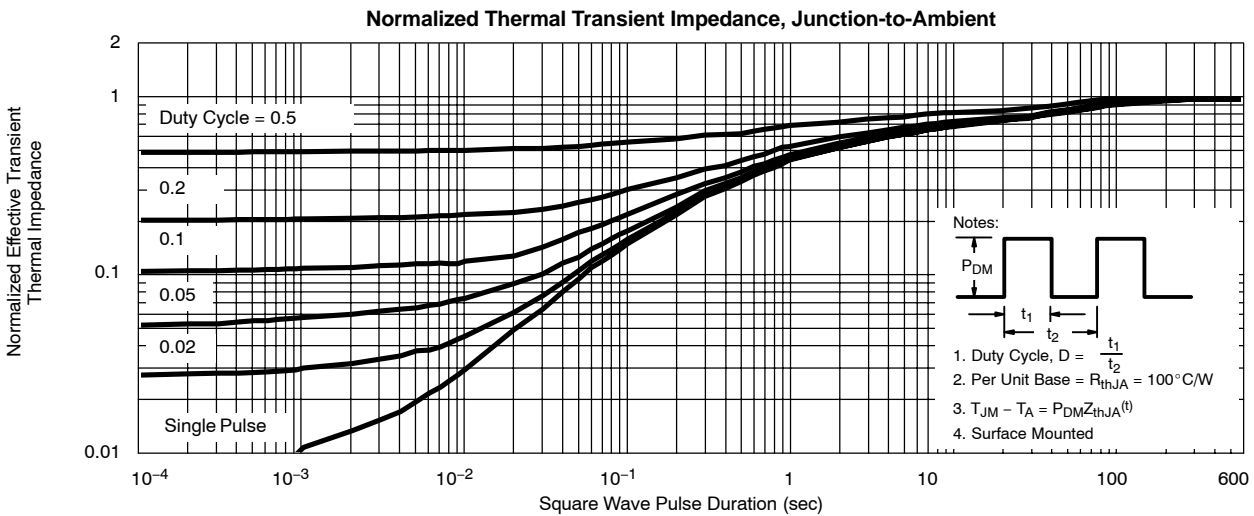
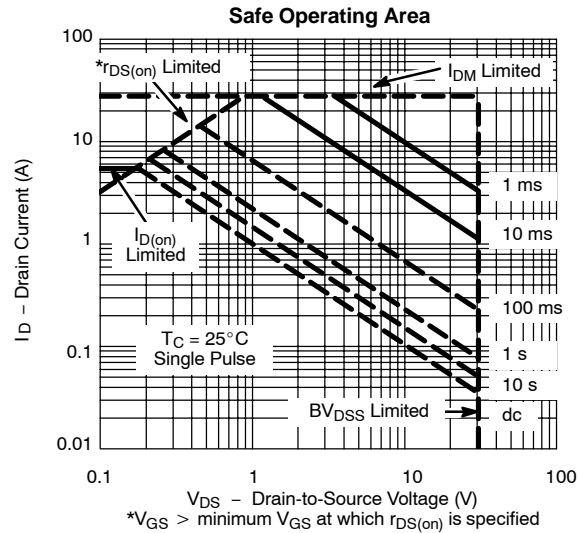

TYPICAL CHARACTERISTICS (25 °C UNLESS NOTED)

CHANNEL-2

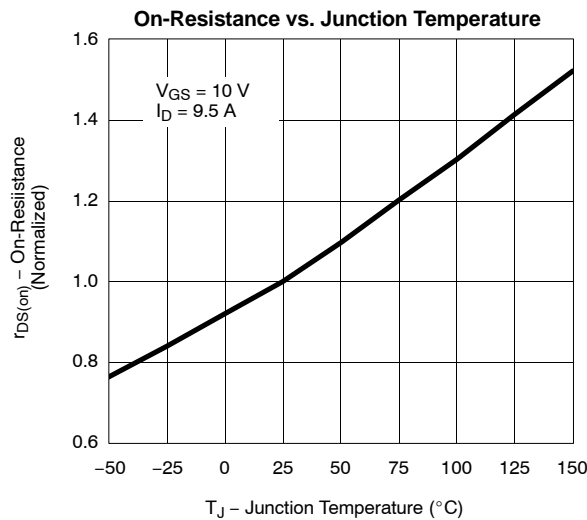
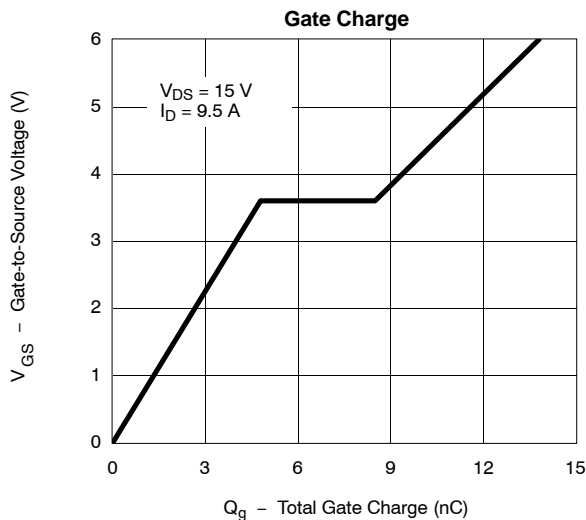
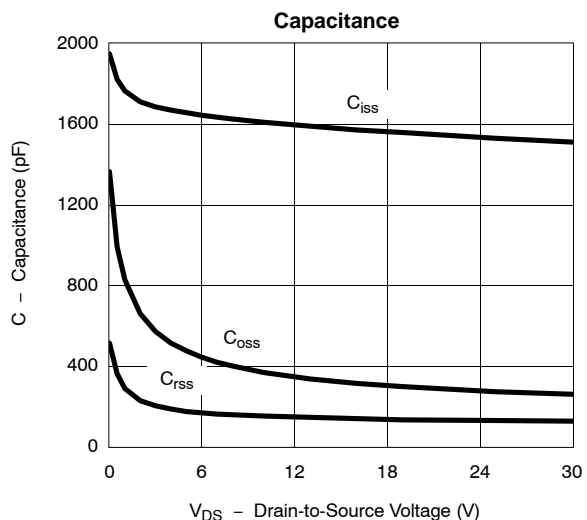
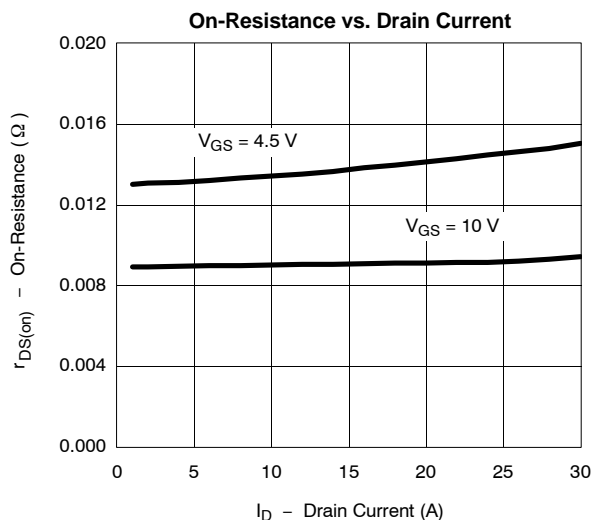
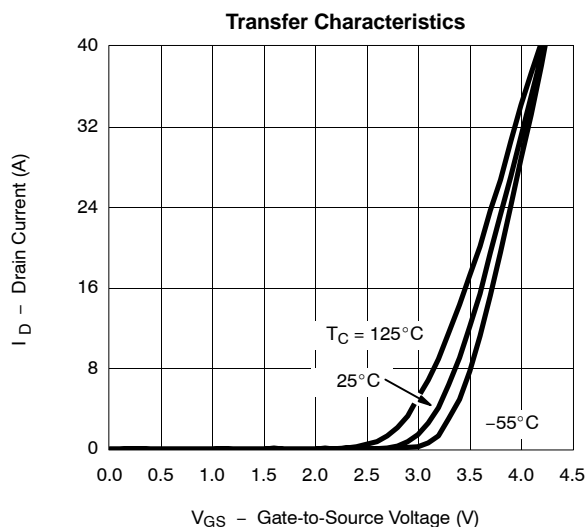
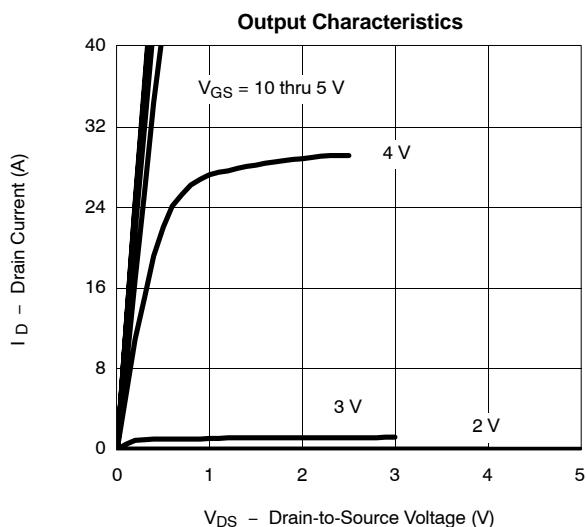



TYPICAL CHARACTERISTICS (25°C UNLESS NOTED)

CHANNEL-2

Source-Drain Diode Forward Voltage

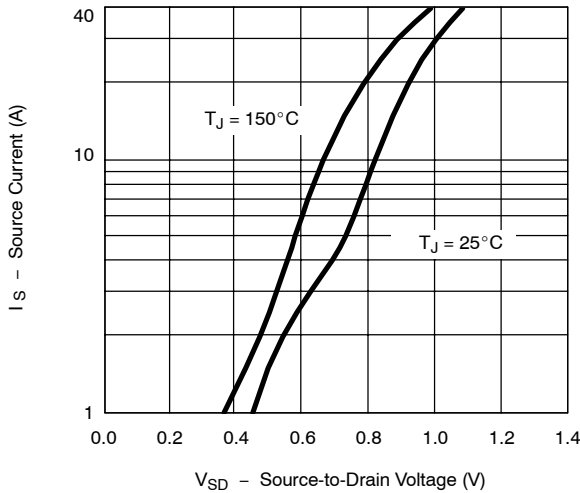

On-Resistance vs. Gate-to-Source Voltage

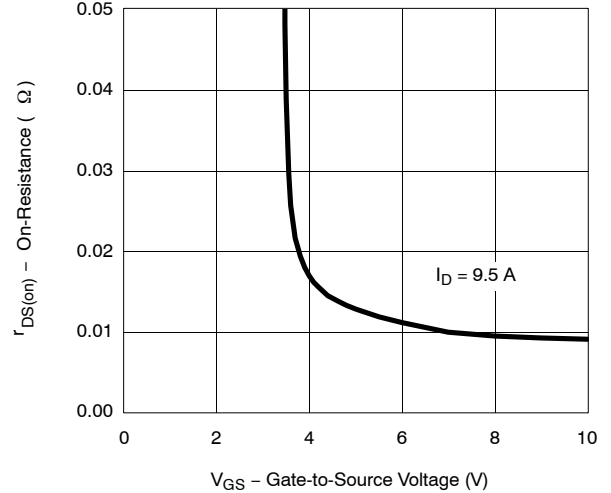

Reverse Current vs. Junction Temperature

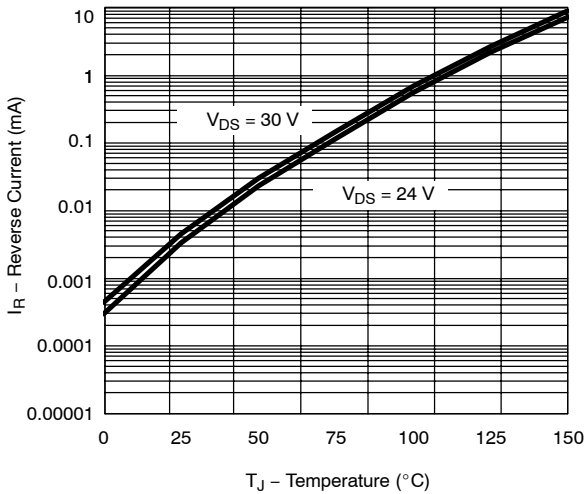

Single Pulse Power, Junction-to-Ambient

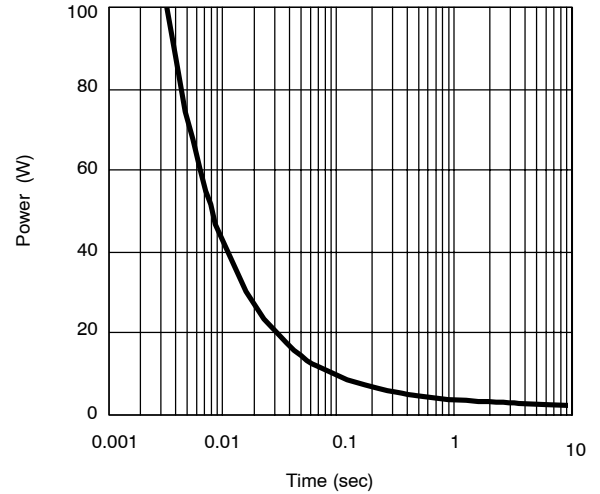

Safe Operating Area

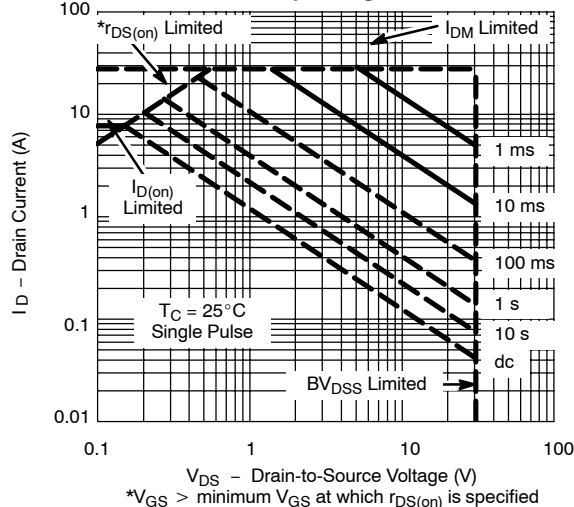

TYPICAL CHARACTERISTICS (25 °C UNLESS NOTED)

CHANNEL-2

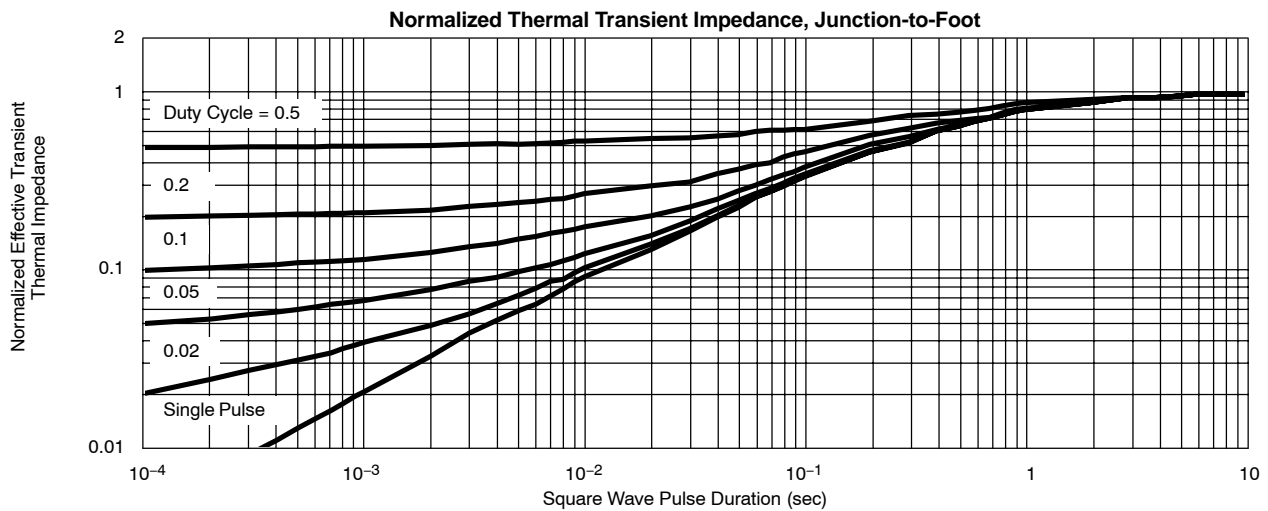
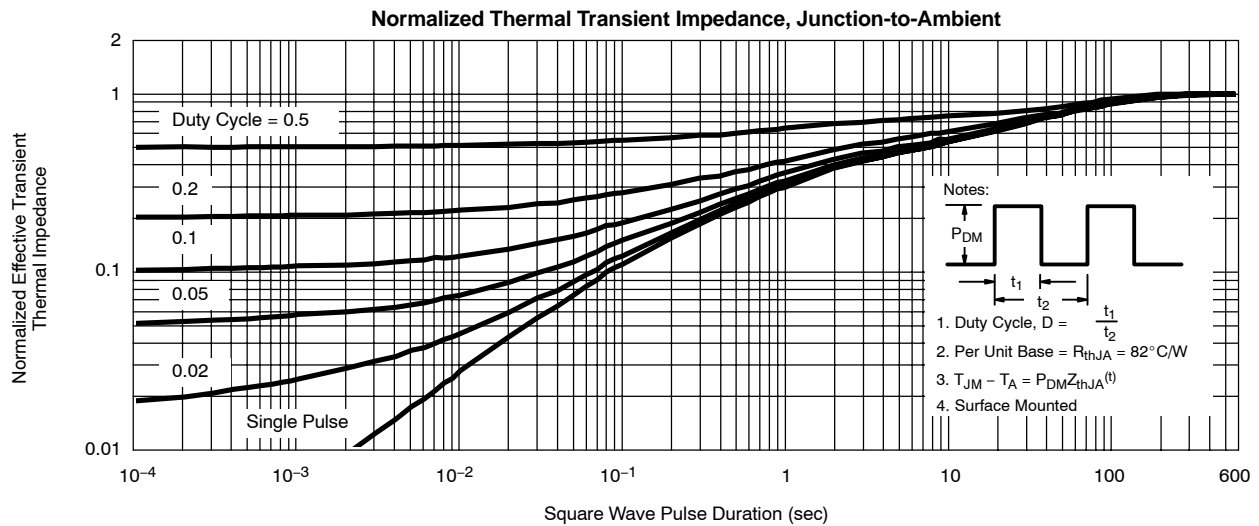



TYPICAL CHARACTERISTICS (25 °C UNLESS NOTED) **SCHOTTKY**

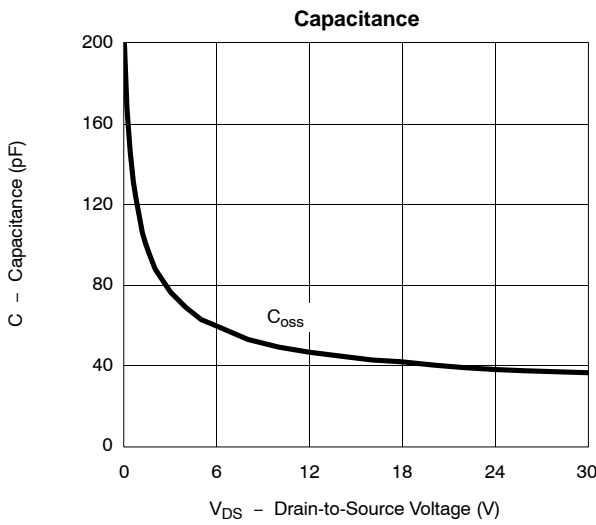
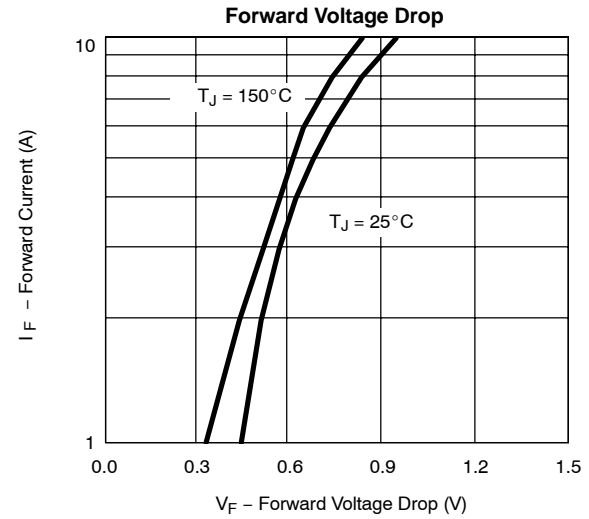
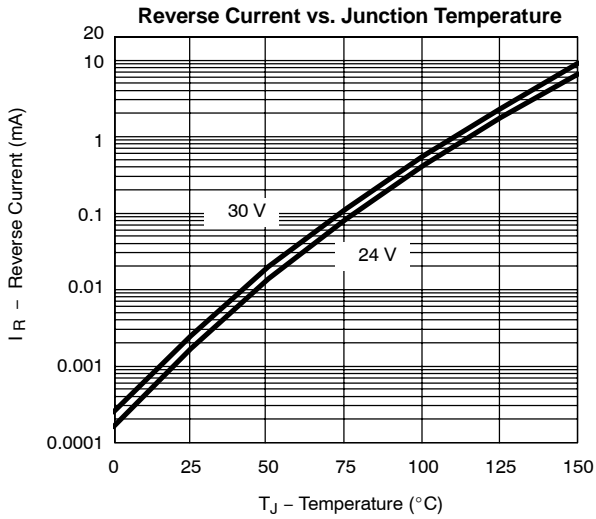

Vishay Siliconix maintains worldwide manufacturing capability. Products may be manufactured at one of several qualified locations. Reliability data for Silicon Technology and Package Reliability represent a composite of all qualified locations. For related documents such as package/tape drawings, part marking, and reliability data, see <http://www.vishay.com/ppg?73026>.