

## Load Switch with Level-Shift

PRODUCT SUMMARY		
$V_{DS2}$ (V)	$r_{DS(on)}$ ( $\Omega$ )	$I_D$ (A)
1.8 to 8	0.080 @ $V_{IN} = 4.5$ V	$\pm 2.7$
	0.110 @ $V_{IN} = 2.5$ V	$\pm 2.2$
	0.175 @ $V_{IN} = 1.8$ V	$\pm 1.7$



**ESD Protected**  
**3000 V**  
**1.8-V Rated**

### FEATURES

- 80-m $\Omega$  Low  $r_{DS(on)}$  TrenchFET™
- 1.8 to 8-V Input
- 1.5 to 8-V Logic Level Control
- Low Profile, Small Footprint TSOP-6 Package
- 3000-V ESD Protection On Input Switch,  $V_{ON/OFF}$
- Adjustable Slew-Rate

### DESCRIPTION

The Si3865DV includes a p- and n-channel MOSFET in a single TSOP-6 package. The low on-resistance p-channel TrenchFET® is tailored for use as a load switch. The n-channel, with an external resistor, can be used as a

level-shift to drive the p-channel load-switch. The n-channel MOSFET has internal ESD protection and can be driven by logic signals as low as 1.5-V. The Si3865DV operates on supply lines from 1.8 to 8-V, and can drive loads up to 2.7 A.

### APPLICATION CIRCUITS

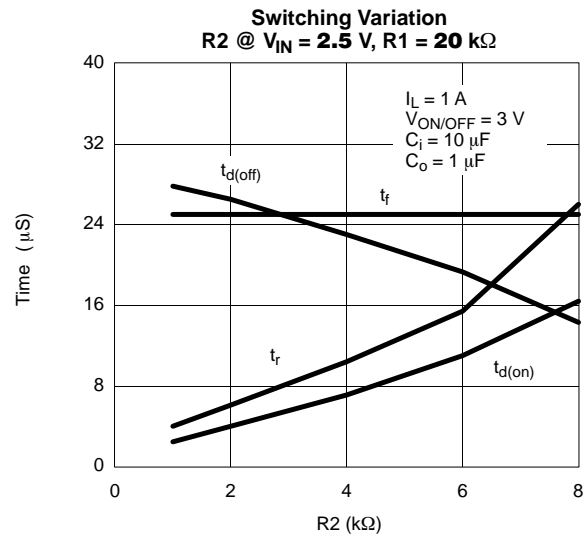
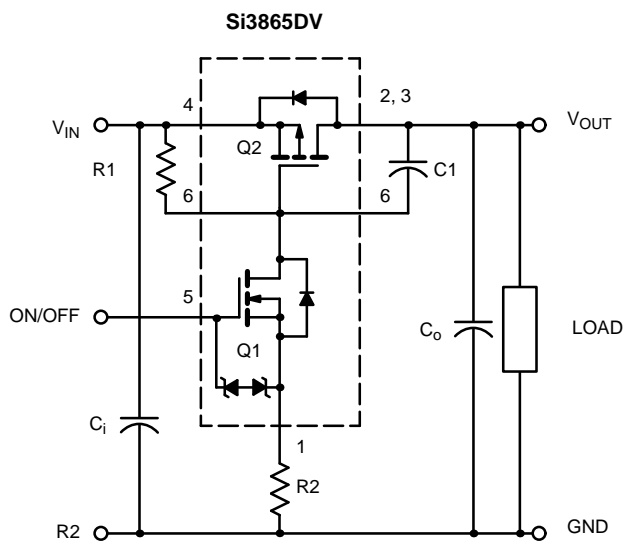

Note: For R2 switching variations with other  $V_{IN}/R1$  combinations See Typical Characteristics

### COMPONENTS

Component	Description	Typical Value
R1	Pull-Up Resistor	Typical 10 k $\Omega$ to 1 m $\Omega$ *
R2	Optional Slew-Rate Control	Typical 0 to 100 k $\Omega$ *
C1	Optional Slew-Rate Control	Typical 1000 pF

\*Minimum R1 value should be at least 10 x R2 to ensure Q1 turn-on.

The Si3865DV is ideally suited for high-side load switching in portable applications. The integrated n-channel level-shift device saves space by reducing external components. The slew rate is set externally so that rise-times can be tailored to different load types.

**FUNCTIONAL BLOCK DIAGRAM**

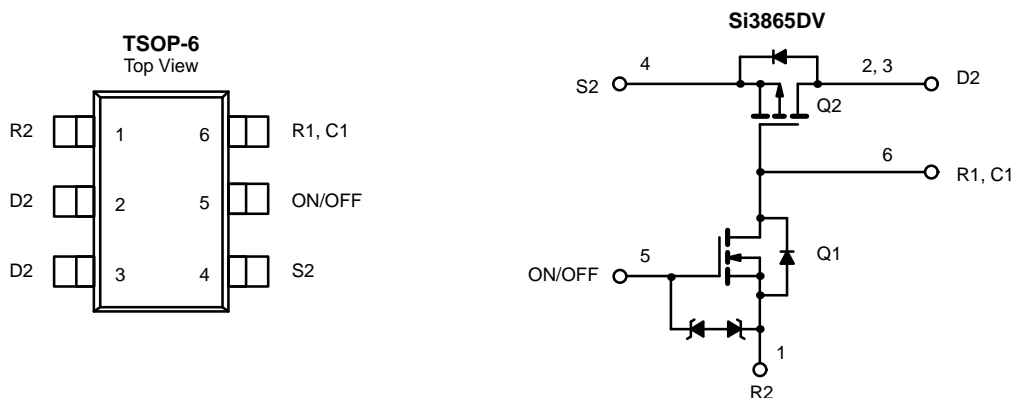

**ABSOLUTE MAXIMUM RATINGS (T<sub>A</sub> = 25 °C UNLESS OTHERWISE NOTED)**

Parameter	Symbol	Limit	Unit
Input Voltage	V <sub>IN</sub>	8	V
ON/OFF Voltage	V <sub>ON/OFF</sub>	8	
Load Current	Continuous <sup>a, b</sup>	±2.7	A
	Pulsed <sup>b, c</sup>	±6	
Continuous Intrinsic Diode Conduction <sup>a</sup>	I <sub>S</sub>	-1	
Maximum Power Dissipation <sup>a</sup>	P <sub>D</sub>	0.83	W
Operating Junction and Storage Temperature Range	T <sub>J</sub> , T <sub>stg</sub>	-55 to 150	°C
ESD Rating, MIL-STD-883D Human Body Model (100 pF, 1500 Ω)	ESD	3	kV

**THERMAL RESISTANCE RATINGS**

Parameter	Symbol	Typical	Maximum	Unit
Maximum Junction-to-Ambient (continuous current) <sup>a</sup>	R <sub>thJA</sub>	120	150	°C/W
Maximum Junction-to-Foot (Q2)	R <sub>thJC</sub>	35	50	

**SPECIFICATIONS (T<sub>J</sub> = 25 °C UNLESS OTHERWISE NOTED)**

Parameter	Symbol	Test Condition	Min	Typ	Max	Unit
<b>OFF Characteristics</b>						
Reverse Leakage Current	I <sub>FL</sub>	V <sub>IN</sub> = 8 V, V <sub>ON/OFF</sub> = 0 V			1	μA
Diode Forward Voltage	V <sub>SD</sub>	I <sub>S</sub> = -1 A		-0.7	-1	V
<b>ON Characteristics</b>						
Input Voltage Range	V <sub>IN</sub>		1.8		8	V
On-Resistance (p-channel) @ 1 A	r <sub>DS(on)</sub>	V <sub>ON/OFF</sub> = 1.5 V I <sub>D</sub> = 1 A	V <sub>IN</sub> = 4.5 V	0.064	0.080	Ω
			V <sub>IN</sub> = 2.5 V	0.092	0.110	
			V <sub>IN</sub> = 1.8 V	0.135	0.175	
On-State (p-channel) Drain-Current	I <sub>D(on)</sub>	V <sub>IN-OUT</sub> ≤ 0.2 V, V <sub>IN</sub> = 5 V, V <sub>ON/OFF</sub> = 1.5 V	1			A
		V <sub>IN-OUT</sub> ≤ 0.3 V, V <sub>IN</sub> = 3 V, V <sub>ON/OFF</sub> = 1.5 V	1			

Notes

- a. Surface Mounted on FR4 Board.
- b. V<sub>IN</sub> = 8 V, V<sub>ON/OFF</sub> = 8 V, T<sub>A</sub> = 25 °C.
- c. Pulse test: pulse width ≤ 300 μs, duty cycle ≤ 2%.



**TYPICAL CHARACTERISTICS (25°C UNLESS NOTED)**

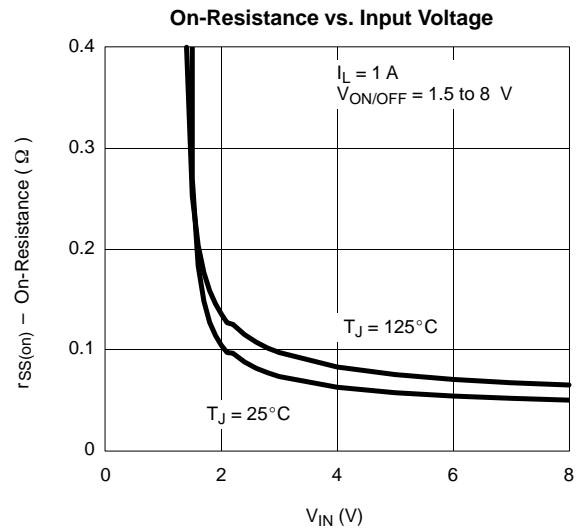
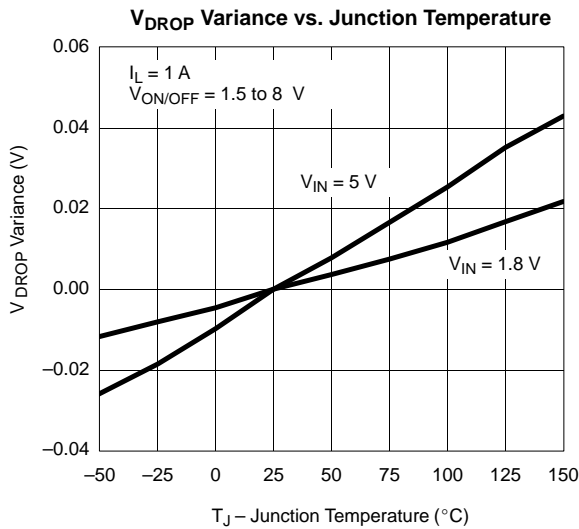
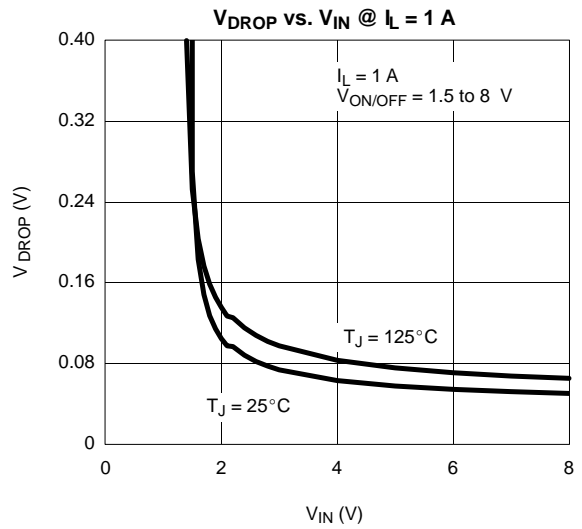
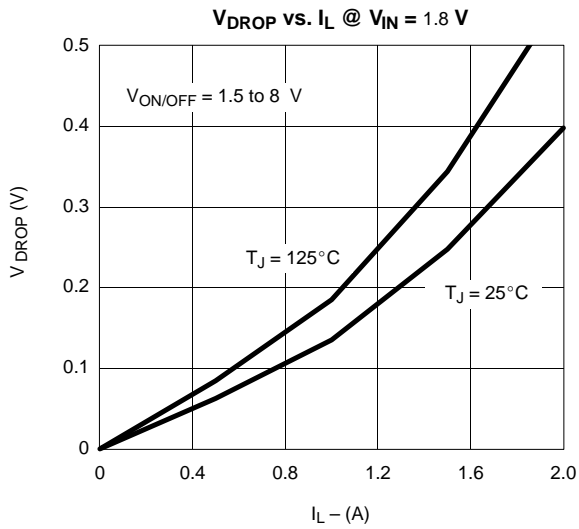
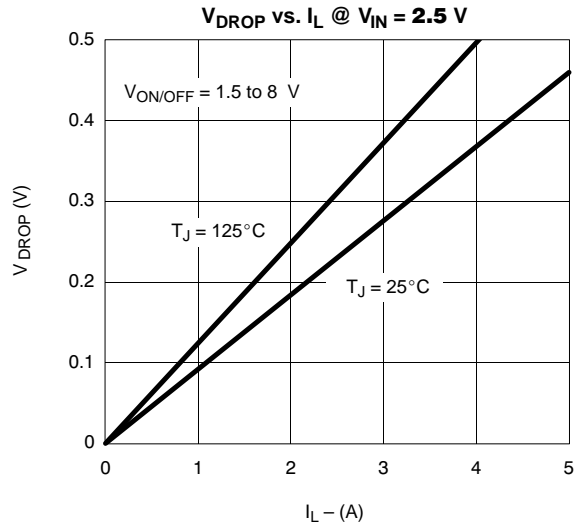
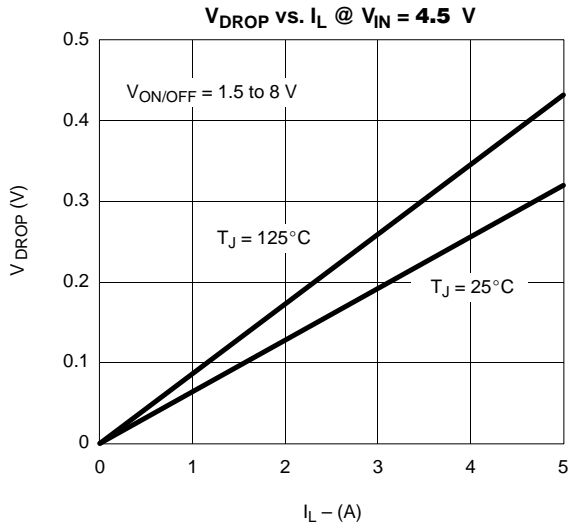



**TYPICAL CHARACTERISTICS (25°C UNLESS NOTED)**

**Normalized On-Resistance vs. Junction Temperature**

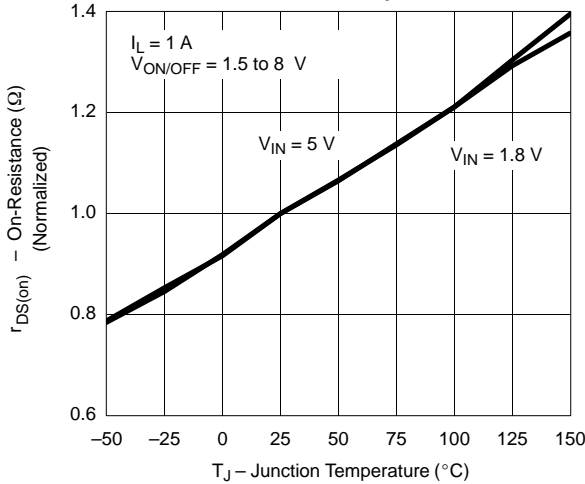

**Switching Variation R2 @ V\_IN = 4.5 V, R1 = 20 kΩ**

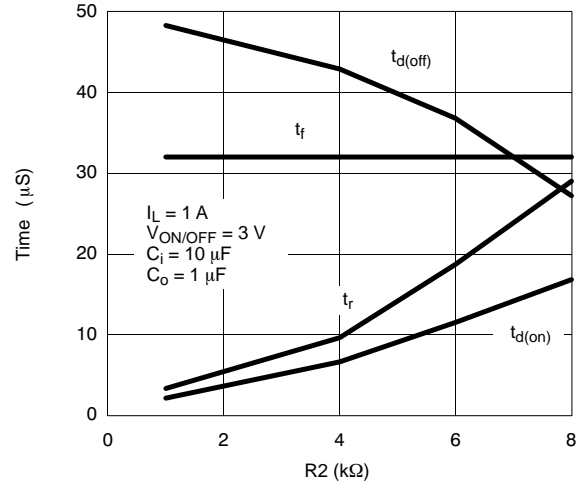

**Switching Variation R2 @ V\_IN = 2.5 V, R1 = 20 kΩ**

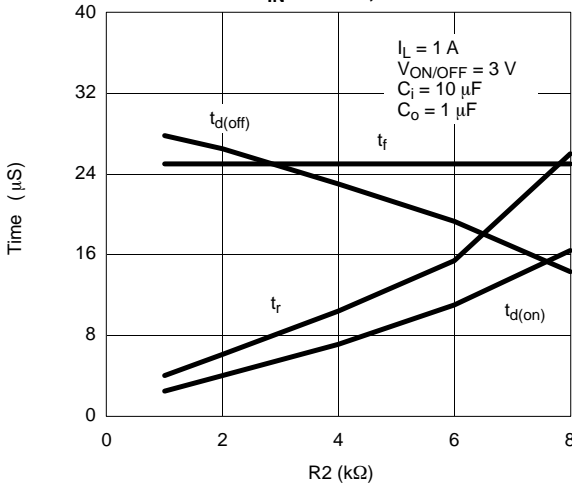

**Switching Variation R2 @ V\_IN = 1.8 V, R1 = 20 kΩ**

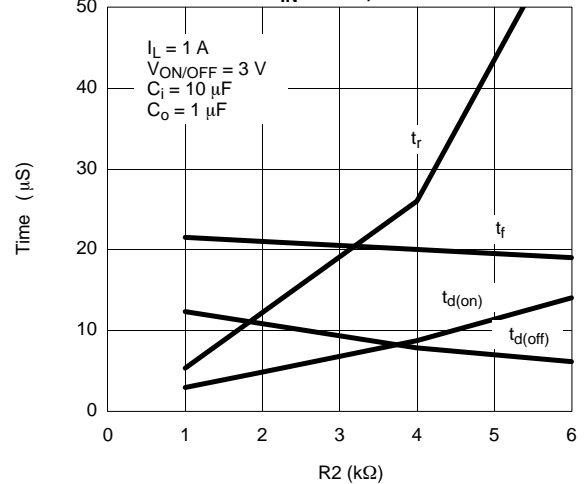

**Switching Variation R2 @ V\_IN = 4.5 V, R1 = 300 kΩ**

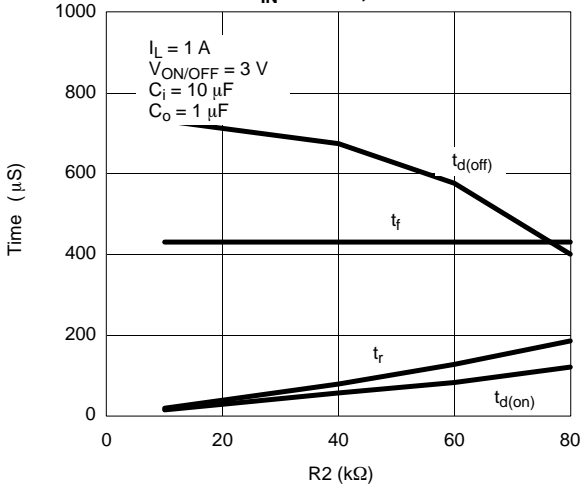

**Switching Variation R2 @ V\_IN = 2.5 V, R1 = 300 kΩ**

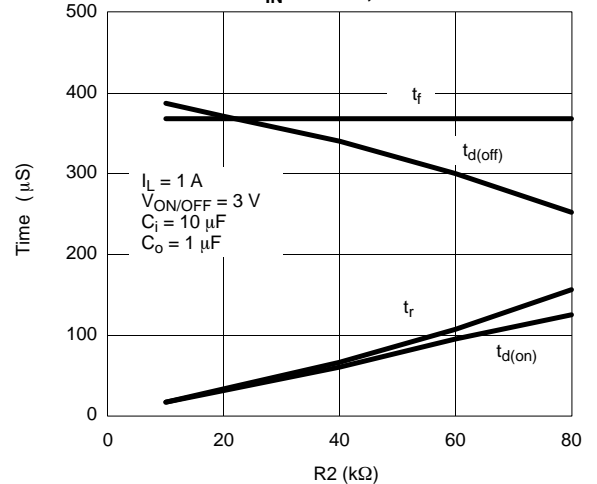

**TYPICAL CHARACTERISTICS (25°C UNLESS NOTED)**

